



BRADCO

BY PALADIN

OPERATOR'S AND PARTS MANUAL

MM36 SERIES II MULCHER



SERIAL NUMBER: _____

MODEL NUMBER: _____

Manual Number: OM791
Part Number: 75691
Rev. 2

READ ENTIRE OPERATOR'S & PARTS MANUAL BEFORE OPERATING!

DANGER! ROTATING DRUM HAZARD! STAY BACK! OBJECTS CAN BE THROWN!
DO NOT operate near bystanders.



DANGER! TO AVOID SERIOUS PERSONAL INJURY OR DEATH THE BRADCO
MULCHER MUST NOT BE ATTACHED TO ANY POWER UNIT THAT
DOES NOT HAVE A FORESTRY GUARD PACKAGE INSTALLED.



DANGER! FLYING DEBRIS HAZARD. CLEAR AREA OF BYSTANDERS AND LIVE-
STOCK BEFORE OPERATING. THE MULCHER IS CAPABLE OF PRO-
DUCING LARGE AMOUNTS OF FLYING DEBRIS IN ALL DIRECTIONS.



WARNING! Before leaving the operator's seat: Lower the attachment to the
ground. Disengage auxiliary hydraulics. Engage the parking brake.
Stop Engine. Remove the key.



WARNING! Use extreme caution when operating “over the side”. Machine stability
is greatly reduced during “over the side” operation of an attachment.



Do not operate the BRADCO Mulcher with a rotator option installed
onto the excavator.

If there is any portion of this manual or function you do not understand, com-
tact your local authorized dealer or the manufacturer.

TABLE OF CONTENTS

PREFACE	3
SAFETY PRECAUTIONS	
SAFETY STATEMENTS	5
GENERAL SAFETY PRECAUTIONS	5-7
EQUIPMENT SAFETY PRECAUTIONS	8-9
DECALS	
DECAL PLACEMENT	10
DECALS	11-12
SET-UP	13-14
INSTALLATION	15-16
OPERATING INSTRUCTIONS	
PREOPERATION	17
INTENDED USE	17
CASE DRAIN	18
OPERATION - STARTING AND STOPPING THE MULCHER	18-19
GENERAL OPERATING TIPS (Ground Speed, Stalling, Jams, Mulching Brush and Trees)	19-20
STORAGE	20
LIFT POINTS	21
TIE DOWN POINTS	21
TRANSPORTING	21
MAINTENANCE AND SERVICE	
GENERAL MAINTENANCE & LUBRICATION	22
BREAK IN PERIOD	23
LUBRICATION SPECIFICATIONS	23
LUBRICATING LOWER BEARINGS	23
REPLACING TEETH	24
DRIVE BELT TENSIONING AND/OR REMOVAL	24-26
SPROCKET REMOVAL AND INSTALLATION	26-28
ROTOR REMOVAL AND INSTALLATION	28
CHECKING AND/OR CHANGING OIL	29-30
REPLACING SKID SHOE WEAR PADS	30
REPLACING AND/OR SERVICING LOWER BEARINGS	31-35
REPLACING AND/OR SERVICING OVERHUNG LOAD ADAPTER	35-37
TROUBLESHOOTING	38-40
SPECIFICATIONS	
BOLT TORQUE SPECIFICATIONS	41
MULCHER SPECIFICATIONS	42
LIMITED WARRANTY	43
PARTS	
MAINFRAME ASSEMBLY	44-45
ROTOR ASSEMBLY	46-47
MOTOR AND DRIVE ASSEMBLY	48-49
HYDRAULIC SYSTEM ASSEMBLY	50-51
OVERHUNG LOAD ADAPTER ASSEMBLY	52-53
RIGHT LOWER BEARING ASSEMBLY	54-55
LEFT LOWER BEARING ASSEMBLY	56-57
TOOTH KIT OPTIONS	58-59
OPTIONAL ACCESSORIES	60-61

**THIS PAGE
IS INTENTIONALLY
BLANK**

PREFACE

GENERAL COMMENTS

Congratulations on the purchase of your new BRADCO product! This product was carefully designed and manufactured to give you many years of dependable service. Only minor maintenance (such as cleaning and lubricating) is required to keep it in top working condition. Be sure to observe all maintenance procedures and safety precautions in this manual and on any safety decals located on the product and on any equipment on which the attachment is mounted.

This manual has been designed to help you do a better, safer job. Read this manual carefully and become familiar with its contents.

WARNING! Never let anyone operate this unit without reading the "Safety Precautions" and "Operating Instructions" sections of this manual.



Always choose hard, level ground to park the vehicle on and set the brake so the unit cannot roll.

Unless noted otherwise, right and left sides are determined from the operator's control position when facing the attachment.

NOTE: The illustrations and data used in this manual were current (according to the information available to us) at the time of printing, however, we reserve the right to redesign and change the attachment as may be necessary without notification.

BEFORE OPERATION

The primary responsibility for safety with this equipment falls to the operator. Make sure the equipment is operated only by trained individuals that have read and understand this manual. If there is any portion of this manual or function you do not understand, contact your local authorized dealer or the manufacturer to obtain further assistance. Keep this manual available for reference. Provide the manual to any new owners and/or operator's

SAFETY ALERT SYMBOL



This is the "Safety Alert Symbol" used by this industry. This symbol is used to warn of possible injury. Be sure to read all warnings carefully. They are included for your safety and for the safety of others working with you.

SERVICE

Use only manufacturer replacement parts. Substitute parts may not meet the required standards.

Record the model and serial number of your unit on the cover of this manual. The parts department needs this information to insure that you receive the correct parts.

SOUND AND VIBRATION

Sound pressure levels and vibration data for this attachment are influenced by many different parameters: some items are listed below (not inclusive):

- prime mover type, age, condition, with or without cab enclosure and configuration
- operator training, behavior, stress level
- job site organization, working material condition, environment

Based on the uncertainty of the prime mover, operator, and job site, it is not possible to get precise machine and operator sound pressure levels or vibration levels for this attachment.

**THIS PAGE
IS INTENTIONALLY
BLANK**

SAFETY STATEMENTS



THIS SYMBOL BY ITSELF OR WITH A WARNING WORD THROUGHOUT THIS MANUAL IS USED TO CALL YOUR ATTENTION TO INSTRUCTIONS INVOLVING YOUR PERSONAL SAFETY OR THE SAFETY OF OTHERS. FAILURE TO FOLLOW THESE INSTRUCTIONS CAN RESULT IN INJURY OR DEATH.



DANGER

THIS SIGNAL WORD IS USED WHERE SERIOUS INJURY OR DEATH WILL RESULT IF THE INSTRUCTIONS ARE NOT FOLLOWED PROPERLY.



WARNING

THIS SIGNAL WORD IS USED WHERE SERIOUS INJURY OR DEATH COULD RESULT IF THE INSTRUCTIONS ARE NOT FOLLOWED PROPERLY.



CAUTION

THIS SIGNAL WORD IS USED WHERE MINOR INJURY COULD RESULT IF THE INSTRUCTIONS ARE NOT FOLLOWED PROPERLY.

NOTICE

NOTICE INDICATES A PROPERTY DAMAGE MESSAGE.

GENERAL SAFETY PRECAUTIONS

WARNING!

READ MANUAL PRIOR TO INSTALLATION



Improper installation, operation, or maintenance of this equipment could result in serious injury or death. Operators and maintenance personnel should read this manual, as well as all manuals related to this equipment and the prime mover thoroughly before beginning installation, operation, or maintenance. **FOLLOW ALL SAFETY INSTRUCTIONS IN THIS MANUAL AND THE PRIME MOVER'S MANUAL(S).**



READ AND UNDERSTAND ALL SAFETY STATEMENTS

Read all safety decals and safety statements in all manuals prior to operating or working on this equipment. Know and obey all OSHA regulations, local laws, and other professional guidelines for your operation. Know and follow good work practices when assembling, maintaining, repairing, mounting, removing, or operating this equipment.



KNOW YOUR EQUIPMENT

Know your equipment's capabilities, dimensions, and operations before operating. Visually inspect your equipment before you start, and never operate equipment that is not in proper working order with all safety devices intact. Check all hardware to ensure it is tight. Make certain that all locking pins, latches, and connection devices are properly installed and secured. Remove and replace any damaged, fatigued, or excessively worn parts. Make certain all safety decals are in place and are legible. Keep decals clean, and replace them if they become worn or hard to read.

GENERAL SAFETY PRECAUTIONS

WARNING!



PROTECT AGAINST FLYING DEBRIS

Always wear proper safety glasses, goggles, or a face shield when driving pins in or out, or when any operation causes dust, flying debris, or any other hazardous material.

WARNING!



LOWER OR SUPPORT RAISED EQUIPMENT

Do not work under raised booms without supporting them. Do not use support material made of concrete blocks, logs, buckets, barrels, or any other material that could suddenly collapse or shift positions. Make sure support material is solid, not decayed, warped, twisted, or tapered. Lower booms to ground level or on blocks. Lower booms and attachments to the ground before leaving the cab or operator's station.

WARNING!



USE CARE WITH HYDRAULIC FLUID PRESSURE

Hydraulic fluid under pressure can penetrate the skin and cause serious injury or death. Hydraulic leaks under pressure may not be visible. Before connecting or disconnecting hydraulic hoses, read your prime mover's operator's manual for detailed instructions on connecting and disconnecting hydraulic hoses or fittings.

- Keep unprotected body parts, such as face, eyes, and arms as far away as possible from a suspected leak. Flesh injected with hydraulic fluid may develop gangrene or other permanent disabilities.
- If injured by injected fluid, see a doctor at once. If your doctor is not familiar with this type of injury, ask him to research it immediately to determine proper treatment.
- Wear safety glasses, protective clothing, and use a piece of cardboard or wood when searching for hydraulic leaks. **DO NOT USE YOUR HANDS!** **SEE ILLUSTRATION.**

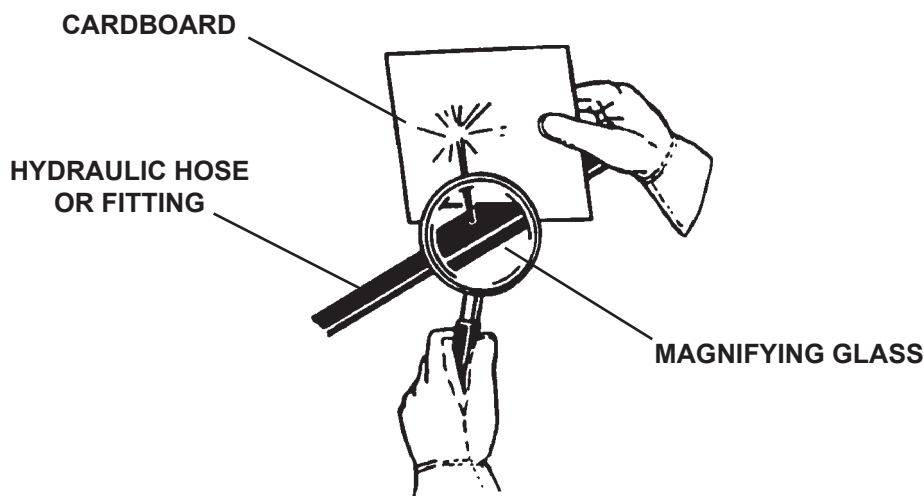

GENERAL SAFETY PRECAUTIONS

WARNING!



DO NOT MODIFY MACHINE OR ATTACHMENTS

Modifications may weaken the integrity of the attachment and may impair the function, safety, life, and performance of the attachment. When making repairs, use only the manufacturer's genuine parts, following authorized instructions. Other parts may be substandard in fit and quality. Never modify any ROPS (Roll Over Protection Structure) or FOPS (Falling Object Protective Structure) equipment or device. Any modifications must be authorized in writing by the manufacturer.

WARNING!



SAFELY MAINTAIN AND REPAIR EQUIPMENT

- Do not wear loose clothing or any accessories that can catch in moving parts. If you have long hair, cover or secure it so that it does not become entangled in the equipment.
- Work on a level surface in a well-lit area.
- Use properly grounded electrical outlets and tools.
- Use the correct tools for the job at hand. Make sure they are in good condition for the task required.
- Wear the protective equipment specified by the tool manufacturer.



SAFELY OPERATE EQUIPMENT

Do not operate equipment until you are completely trained by a qualified operator in how to use the controls, know its capabilities, dimensions, and all safety requirements. See your machine's manual for these instructions.

- Keep all step plates, grab bars, pedals, and controls free of dirt, grease, debris, and oil.
- Never allow anyone to be around the equipment when it is operating.
- Do not allow riders on the attachment or the prime mover.
- Do not operate the equipment from anywhere other than the correct operator's position.
- Never leave equipment unattended with the engine running, or with this attachment in a raised position.
- Do not alter or remove any safety feature from the prime mover or this attachment.
- Know your work site safety rules as well as traffic rules and flow. When in doubt on any safety issue, contact your supervisor or safety coordinator for an explanation.

EQUIPMENT SAFETY PRECAUTIONS

WARNING!



KNOW WHERE UTILITIES ARE

Observe overhead electrical and other utility lines. Be sure equipment will clear them. When digging, call your local utilities for location of buried utility lines, gas, water, and sewer, as well as any other hazard you may encounter.

WARNING!



EXPOSURE TO RESPIRABLE CRYSTALLINE SILICA DUST ALONG WITH OTHER HAZARDOUS DUSTS MAY CAUSE SERIOUS OR FATAL RESPIRATORY DISEASE.

It is recommended to use dust suppression, dust collection and if necessary personal protective equipment during the operation of any attachment that may cause high levels of dust.

WARNING!



REMOVE PAINT BEFORE WELDING OR HEATING

Hazardous fumes/dust can be generated when paint is heated by welding, soldering or using a torch. Do all work outside or in a well ventilated area and dispose of paint and solvent properly. Remove paint before welding or heating.

When sanding or grinding paint, avoid breathing the dust. Wear an approved respirator. If you use solvent or paint stripper, remove stripper with soap and water before welding. Remove solvent or paint stripper containers and other flammable material from area. Allow fumes to disperse at least 15 minutes before welding or heating.

WARNING!



END OF LIFE DISPOSAL

At the completion of the useful life of the unit, drain all fluids and dismantle by separating the different materials (rubber, steel, plastic, etc.). Follow all federal, state and local regulations for recycling and disposal of the fluid and components.



OPERATING THE MULCHER

- Block off work area from bystanders, livestock, etc. Flying debris can cause severe injury or death. The mulcher is capable of producing large amounts of flying debris in all directions.
- Do NOT operate without a forestry guard package installed on prime mover.
- Operate only from the operator's station.
- Be aware when mulching standing trees, there is a danger of the treetop falling back onto the operator's cab.
- Do not contact tracks or boom during mulcher operation. It is recommended to maintain a minimum 90° angle between the boom and dipper to prevent the mulcher contacting the excavator.
- Do not engage or disengage the drum while the engine rpm's are above low idle.
- Do not operate the mulcher with a rotator option installed on the excavator.
- Use extreme caution when operating "over the side". Machine stability is greatly reduced during "over the side" operation of an attachment.
- Do not lift loads in excess of the capacity of the excavator. Lifting capacity decreases as the load is moved further away from the unit.
- When operating on slopes, drive up and down, not across. Avoid steep hillside operation, which could cause the excavator to overturn. Avoid changing direction of travel on a slope. This could cause tipping or side slipping of the machine.
- Reduce speed when driving over rough terrain, on a slope, or turning, to avoid overturning the vehicle.

12007 12-15-11

EQUIPMENT SAFETY PRECAUTIONS



OPERATING THE MULCHER (Continued)

- The mulcher should not be used as a parking brake to immobilize your prime mover or used in any way to assist in moving your prime mover. Follow the instructions in your prime mover operator's manual before leaving the operator's station.
- An operator must not use drugs or alcohol, which can change his or her alertness or coordination. An operator taking prescription or over-the-counter drugs should seek medical advice on whether or not he or she can safely operate equipment.
- Before exiting the prime mover, lower the attachment to the ground, apply the brakes, turn off the prime mover's engine and remove the key.



TRANSPORTING THE MULCHER

- Travel only with the attachment in a safe transport position to prevent uncontrolled movement. Drive slowly over rough ground and on slopes.
- When transporting on a trailer, secure attachment at recommended tie down locations using tie down accessories that are capable of maintaining attachment stability.
- Watch for proper clearance of the boom and mulcher during transporting. Uneven ground can cause the boom to move in all directions.
- When driving on public roads use safety lights, reflectors, Slow Moving Vehicle signs etc., to prevent accidents. Check local government regulations that may affect you.
- Do not drive close to ditches, excavations, etc., cave in could result.
- Do not smoke when refueling the prime mover. Allow room in the fuel tank for expansion. Wipe up any spilled fuel. Secure cap tightly when done.



MAINTAINING THE MULCHER

- Before performing maintenance, disengage auxiliary hydraulics, lower the attachment to the ground, apply the brakes, turn off the engine and remove the key.
- Never perform any work on the attachment unless you are authorized and qualified to do so. Always read the operator's manual before any repair is made. After completing maintenance or repair, check for correct functioning of the attachment. If not functioning properly, always tag "DO NOT OPERATE" until all problems are corrected.
- Worn, damaged, or illegible safety decals must be replaced. New safety decals can be ordered from BRADCO.
- Never make hydraulic repairs while the system is under pressure. Serious personal injury or death could result.
- Never work under a raised attachment.

DECAL PLACEMENT

GENERAL INFORMATION

The diagrams on this page shows the location of the decals used on the BRADCO 36" Series II Mulchers. The decals are identified by their part numbers, with reductions of the actual decals located on the following pages. Use this information to order replacements for lost or damaged decals. Be sure to read all decals before operating the attachment. They contain information you need to know for both safety and longevity.

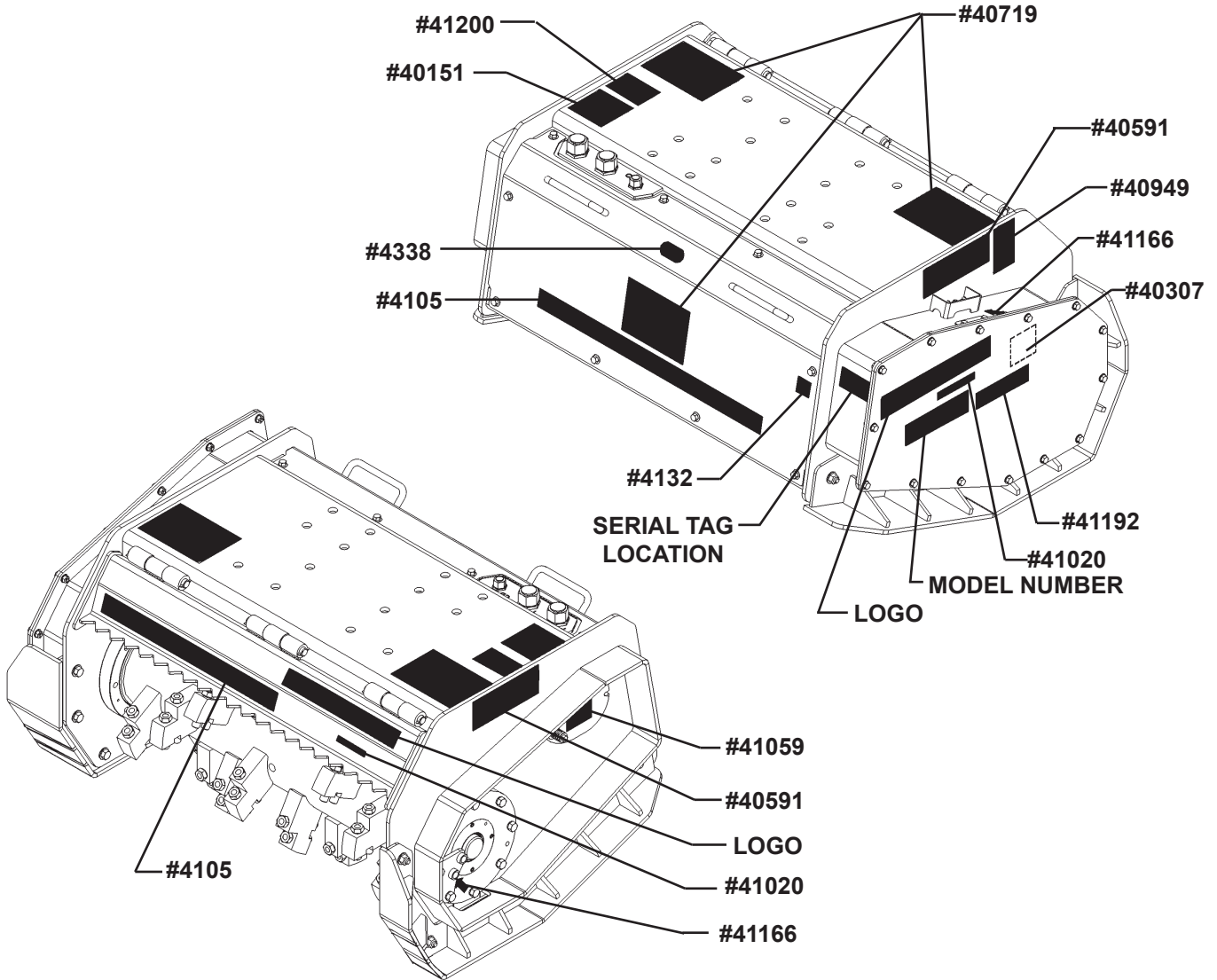

IMPORTANT: Keep all safety signs clean and legible. Replace all missing, illegible, or damaged safety signs. When replacing parts with safety signs attached, the safety signs must also be replaced.

REPLACING SAFETY SIGNS: Clean the area of application with nonflammable solvent, then wash the same area with soap and water. Allow the surface to fully dry. Remove the backing from the safety sign, exposing the adhesive surface. Apply the safety sign to the position shown in the diagram above and smooth out any bubbles.

12002 12-14-11

DECALS



DANGER! FLYING DEBRIS
PART #40719



WARNING! GUARDS
PART #40949

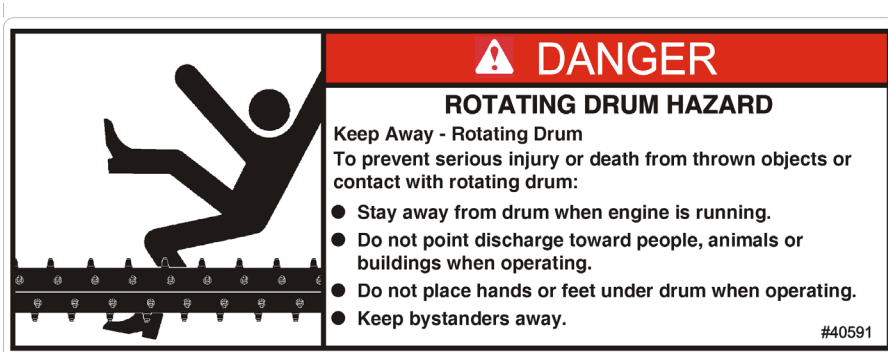

DANGER! ROTATING DRUM
PART #40591

DANGER STAND CLEAR

DANGER! STAND CLEAR
PART #4105



DANGER! GUARD MISSING
PART #40307



WARNING! HIGH PRESSURE FLUID
PART #40151

DECALS

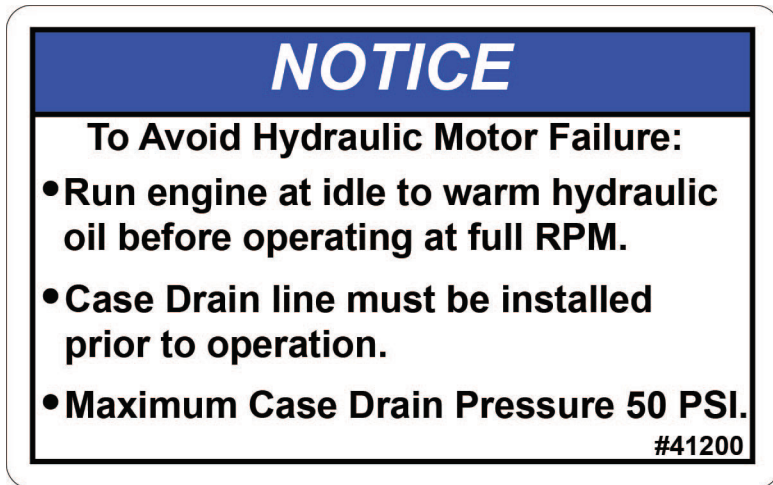

NOTICE! MOTOR FAILURE
PART #41200

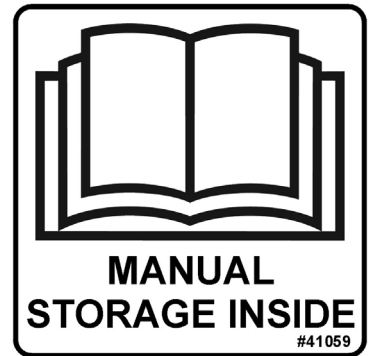

MANUAL STORAGE INSIDE
PART #41059



MULCHER LOGO
PART #41020



SERIES II
PART #41192

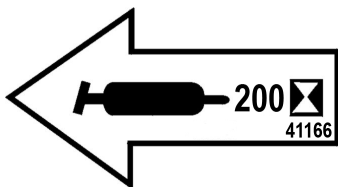

GREASE EVERY 200 HOURS
PART #41166



MADE IN U.S.A.
PART #4338

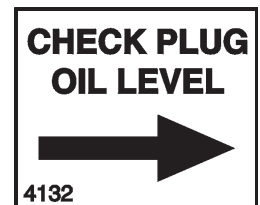

CHECK OIL LEVEL
PART #4132

NOTE: CONTACT YOUR LOCAL DEALER FOR MODEL NUMBER AND LOGO DECALS.

REFER TO WWW.PALADINBRANDS.COM FOR PATENT INFORMATION ON THE SERIES II MULCHERS.

SET-UP

MOTOR DISPLACEMENT

Due to the range of excavators the BRADCO Series II mulcher is designed for, the motor displacement is adjustable to various GPM and rotor RPM to give you optimum productivity for your particular application. The displacement must be adjusted and then “locked in” to create a “fixed” displacement motor that will continue to allow your unit to determine its own load capacity.

For optimum productivity and proper operation the displacement on the mulcher motor needs to be adjusted for the “ACTUAL” GPM of your excavator and the desired RPM of the mulcher rotor. With the engine at full throttle, set the rotor RPM between 1800 - 2000 RPM. (Factory settings are 40 CC on the 115620 mulcher and 50 CC on the 115621 mulcher.)

NOTICE: *Insufficient RPM (below 1800) will greatly reduce the productivity of your unit while overspeeding (above 2000) can cause serious damage to the motor and teeth.*

See the charts on the following page for correct adjustment of the displacement screw for the motor minimum displacement.

To Adjust Minimum Displacement Screw:

Loosen and hold the locking nut while turning the minimum displacement screw to the desired dimension and then hold the displacement screw while turning the locking nut and therefore locking it in place.

It is recommended that the drum RPM be checked with a tachometer after adjustments have been completed. To increase RPM, increase “X” dimension. To decrease RPM decrease the “X” dimension.

Once the minimum displacement screw has been adjusted for the GPM of your machine and the rotor RPM required for optimum productivity, the maximum displacement screw must also be adjusted.

To Adjust Maximum Displacement Screw:

Completely loosen the locking nut on the maximum displacement screw. Turn the displacement screw in, by hand, until it bottoms out. (Verify that the locking nut does not make contact with the motor before the displacement screw bottoms out on the swash plate.) Then HOLD the displacement screw while turning the locking nut and therefore locking the motor displacement.

NOTE: To change the displacement and lower the RPM you will be required to back off on the maximum displacement screw before any re-adjustments can be made.

IMPORTANT: Prime mover must be at operating temperature prior to checking the rotor RPM with a tachometer.

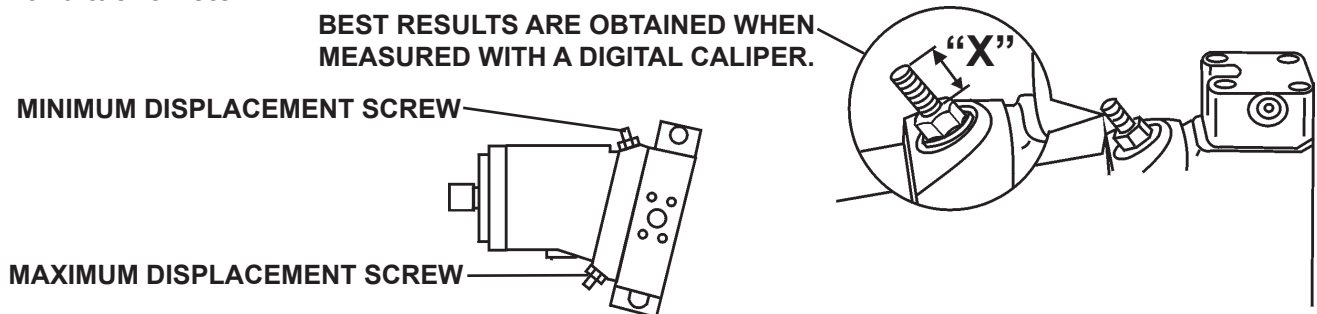

The 55CC motor (#112700) includes a 5mm allen wrench and 17mm wrench to adjust the displacement screws. The 80CC motor (#107251) includes a 6mm allen wrench and 19mm wrench to adjust the displacement screws.

12009 12-15-11

SET-UP

112700 HYDRAULIC MOTOR (28-41 GPM) (MULCHER ASSEMBLY #115620)						
	1800 ROTOR RPM		1900 ROTOR RPM		2000 ROTOR RPM	
GPM	DISPLACEMENT (CC)	SCREW (M10X90) DIMENSION X (IN)	DISPLACEMENT (CC)	SCREW (M10X90) DIMENSION X (IN)	DISPLACEMENT (CC)	SCREW (M10X90) DIMENSION X (IN)
28	35.3	.97	33.5	1.02	31.8	1.07
29	36.6	.93	34.7	.99	32.9	1.04
30	37.9	.90	35.9	.95	34.1	1.00
31	39.1	.86	37.1	.92	35.2	.97
32	40.4	.83	38.3	.88	36.3	.94
33	41.6	.79	39.4	.85	37.5	.91
34	42.9	.75	40.6	.82	38.6	.87
35	44.2	.72	41.8	.78	39.7	.84
36	45.4	.68	43.0	.75	40.9	.81
37	46.7	.64	44.2	.71	42.0	.78
38	47.9	.61	45.4	.68	43.2	.75
39	49.2	.57	46.6	.65	44.3	.71
40	50.5	.54	47.8	.61	45.4	.68
41	51.7	.50	49.0	.58	46.6	.65
42	---	---	50.2	.54	47.7	.62
43	---	---	51.4	.51	48.8	.58
44	---	---	---	---	50.0	.55
45	---	---	---	---	51.1	.52
46	---	---	---	---	52.2	.49

107251 HYDRAULIC MOTOR (42-60 GPM) (MULCHER ASSEMBLY #115621)						
	1800 ROTOR RPM		1900 ROTOR RPM		2000 ROTOR RPM	
GPM	DISPLACEMENT (CC)	SCREW (M12X100) DIMENSION X (IN)	DISPLACEMENT (CC)	SCREW (M12X100) DIMENSION X (IN)	DISPLACEMENT (CC)	SCREW (M12X100) DIMENSION X (IN)
42	53.0	1.01	50.2	1.08	47.7	1.13
43	54.3	.99	51.4	1.05	48.8	1.11
44	55.5	.96	52.6	1.02	50.0	1.08
45	56.8	.93	53.8	1.00	51.1	1.06
46	58.0	.90	55.0	.97	52.2	1.03
47	59.3	.87	56.2	.94	53.4	1.01
48	60.6	.84	57.4	.92	54.5	.98
49	61.8	.81	58.6	.89	55.6	.95
50	63.1	.79	59.8	.86	56.8	.93
51	64.4	.76	61.0	.83	57.9	.90
52	65.6	.73	62.2	.81	59.1	.88
53	66.9	.70	63.4	.78	60.2	.85
54	68.1	.67	64.6	.75	61.3	.83
55	69.4	.64	65.7	.73	62.5	.80
56	70.7	.62	66.9	.70	63.6	.77
57	71.9	.59	68.1	.67	64.7	.75
58	73.2	.56	69.3	.65	65.9	.72
59	74.4	.53	70.5	.62	67.0	.70
60	75.7	.50	71.7	.59	68.1	.67

12010 12-15-11

INSTALLATION

GENERAL INFORMATION

The BRADCO Series II Mulchers were designed to be easy to use and maintain. They are operated by the excavator's auxiliary hydraulics. Due to the various different excavators that this attachment can be mounted on, the mulchers are shipped without hydraulic hoses and couplers. These can be purchased from your local dealer.

HOSE REQUIREMENTS:

Power and return hoses and couplers along with a case drain hose and coupler must be purchased from your dealer to install the mulcher onto your excavator. The hoses must be long enough not to bind or pinch during operation and the power and return hoses must be rated for the maximum hydraulic pressure of your excavator's hydraulic system. Hose diameter should be such to prevent pressure drop on the oil entering the attachment and backpressure on the oil returning to the excavator.

Case drain line must be hooked up to the excavator hydraulic tank with less than 50 psi. During installation the case drain line must be connected first followed by the power and return hoses.

NOTICE: *The mulcher requires 28-60 GPM for productive operation.*

NOMENCLATURE

Throughout this manual, reference is made to various mulcher components. Study the following diagram to acquaint yourself with the various names of these components. This knowledge will be helpful when reading through this manual or when ordering service parts. There is a complete parts breakdown for the mulcher at the back of this manual.

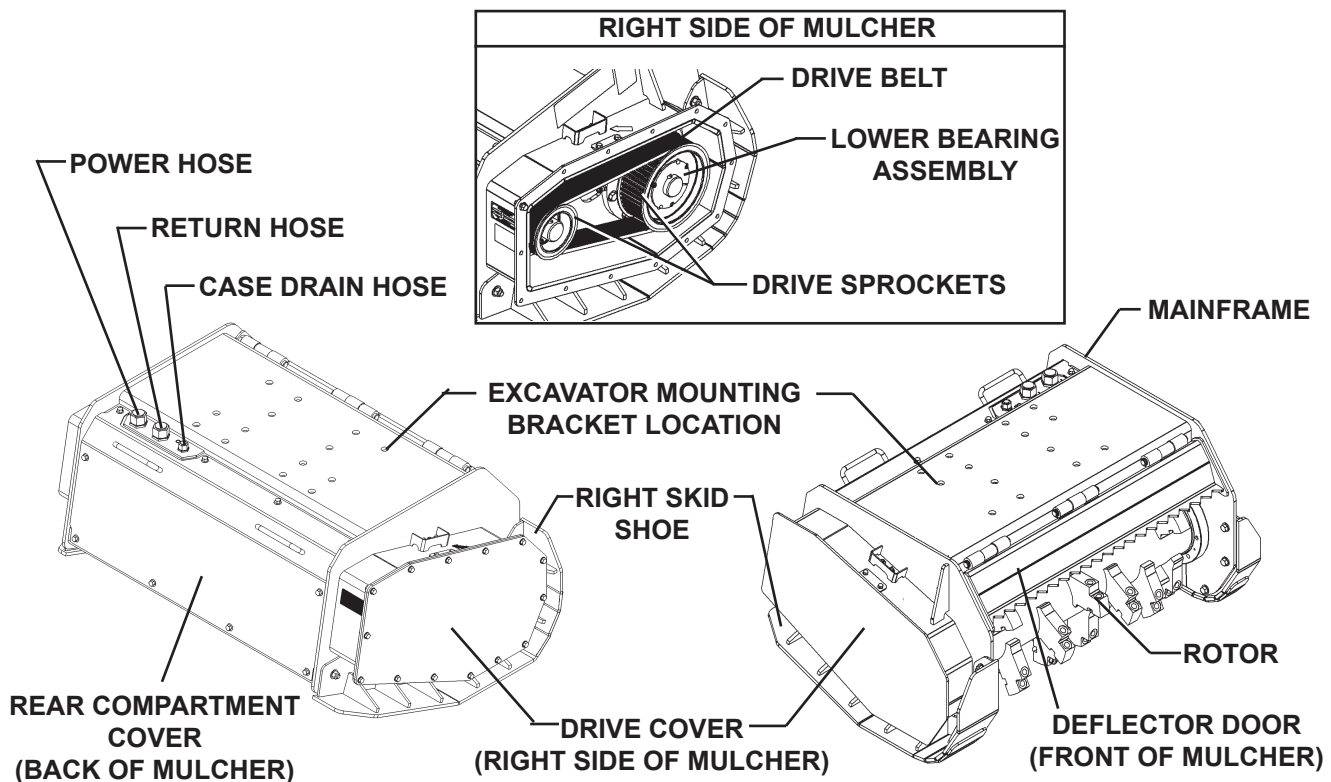

12011 12-15-11

INSTALLATION

ATTACHING

A separate mounting kit is required to install the BRADCO Mulcher onto your excavator. Install the mounting bracket to the mulcher mounting plate and then install the mulcher to your excavator by following your prime mover operator's manual for proper installation of an attachment. When attaching the hoses to the excavator, the case drain line must be connected first, then the power and return hoses. When disconnecting the hoses, it is recommended to disconnect the case drain line last. This will prevent any over pressurization of the motor case on the mulcher head.

NOTE: The case drain line must be installed from the mulcher head to the excavator hydraulic tank. The case drain line must be unrestricted all the way to the tank.

IMPORTANT: Over pressurization of motor case can be caused by a kinked or pinched hose, improper connection, obstruction or damaged coupler on the case drain line. Make necessary adjustments and/or reroute hoses before operating. Route hoses in such a fashion to prevent pinching or chafing.

WARNING! To Avoid Serious Personal Injury, make sure the mulcher is securely latched to the attachment mechanism of your unit. Failure to do so could result in separation of the attachment from the unit.



Clear the area of all bystanders during installation.

DETACHING

On firm, level ground. Lower the mulcher to the ground.

Follow your prime mover operator's manual to relieve pressure in the hydraulic lines.

Disconnect couplers. (When disconnecting the hoses, it is recommended to disconnect the case drain line last. This will prevent any over pressurization of the motor case on the mulcher head.)

NOTE: Connect couplers together or install dust caps and plugs to prevent contaminants from entering the hydraulic system. Store hoses on attachment off the ground.

Follow your prime mover operator's manual for detaching (removing) an attachment.

WARNING! Clear the area of all bystanders during removal.



IMPORTANT: DISENGAGE THE AUXILIARY HYDRAULICS, STOP THE ENGINE, ENGAGE PARKING BRAKE AND REMOVE KEY BEFORE LEAVING THE OPERATOR'S STATION.

OPERATION

PREOPERATION

To determine if the BRADCO Series II mulcher will operate efficiently on your excavator, engage your auxiliary hydraulics and check to make certain you still have complete functionality of the boom, dipper and bucket tilt hydraulic circuits.

NOTICE: *Your excavator application may require that a priority valve be added to the auxiliary circuit so that the excavator functions have priority over the auxiliary circuit. This will insure that when the mulcher is engaged you still have the ability to operate the boom, dipper and bucket tilt functions on your excavator. Contact your prime mover dealer.*

INTENDED USE: This unit was designed to mulch brush and small trees (up to 6"-8" in diameter), and mulching and/or mixing debris approximately 1.50" below ground level. Use in any other way is considered contrary to the intended use.

WARNING! To prevent serious injury or death, this attachment should not be used as a parking brake to immobilize your prime mover or used in any way to assist in moving your prime mover. Follow the instructions in your prime mover operator's manual before leaving the operator's station.



GENERAL INFORMATION

The BRADCO 36" Mulcher is perfect for clearing tall weeds, heavy brush and hardwood tree's up to 6"-8" in diameter. There are two 36" mulchers available for use on excavators with 28-41 GPM or 42-60 GPM. Thorough knowledge of the excavator is necessary for machine operation. Read and understand your prime mover operator's manual before attempting to use the mulcher.

Follow the installation instructions for installing the mulcher onto your excavator.

WARNING! Block off the work area from bystanders and livestock. Flying debris can cause severe personal injury or death.



Do not operate without a forestry guard package on your prime mover.
Do not engage or disengage the drum while the engine rpm's are above a low idle.

WARNING! Before exiting the prime mover, lower the attachment to the ground, disengage auxiliary hydraulics, apply the brakes, turn off the engine and remove the key.



OPERATION

CASE DRAIN

The maximum case drain pressure is 50 PSI. The case drain hose coming from the mulcher to the prime mover must never become pinched, removed from the machine while in operation, or have any type of restriction at any time. Any quick connect fitting used on the case drain line should be bi-directional, with no check valve or flow restrictions. Any type of restriction in this line will cause severe hydraulic system damage and could void warranty. When connecting the mulcher onto your unit you should always connect the case drain line first, and when disconnecting the mulcher you should always disconnect the case drain line last.

NOTE: Oil leaking out of the optional case drain relief valve can be caused by a kinked hose, improper connection, obstruction or a damaged coupler on the case drain line. Make any necessary adjustments before operating the mulcher. If your unit is not equipped with an optional case drain relief valve, check for kinked hoses, improper connections, obstructions or damaged couplers before operating to prevent over pressurization of the motor case causing severe hydraulic system damage which is not covered by warranty.

OPERATION

DANGER!  **To avoid serious personal injury or death the BRADCO mulcher must not be attached to any prime mover that does not have a forestry guard package installed.**

Read and understand all warnings and precautions in this manual and on the machine before operating the mulcher. The Bradco mulcher is relatively simple to use, and with the help of the information in this manual and a little practice you should become proficient in its operation and able to develop procedures suitable to your particular situation.

Starting The Mulcher

1. Start the attachment with the engine at an idle only.

NOTE: The rotor will only turn in one direction. If rotor is not turning check for proper hydraulic hose hook up. If you have the correct hydraulic hook up and rotor is still not turning, idle the engine all the way down as far as it will go and disengage the auxiliary hydraulics. Check for proper flow direction and repair or correct. (You must never change the direction while the rotor is in motion.) Failure to follow this shut down and restart procedure will cause severe damage to the hydraulic system of the attachment and void all warranties.

2. Run the engine at an idle to warm hydraulic oil before accelerating to avoid hydraulic motor failure.
3. Position the prime mover, check that all personnel and bystanders are out of the area, and increase engine speed.

OPERATION

WARNING! Block off work area. Flying debris can cause severe injury or death. This mulcher is capable of producing large amounts of flying debris in all directions.



4. Be sure the mulcher is operating smoothly at full throttle and then start mulching operation. **NOTE: All mulching operations must be done with the excavator stationary. Do not mulch while the excavator is in motion.**

NOTICE: *Continual monitoring of hydraulic oil temperature and water temperature of the prime mover is required during mulcher operation. If temperature rises too high the mulcher must be removed from the brush/debris and the prime mover returned to an idle until it has cooled down sufficiently to continue operation.*

Stopping The Rotor

Disengage the rotor by first idling the engine all the way down and allow the rotor to slow down as far as it will go and then disengage the auxiliary hydraulics. Failure to follow this shut down procedure will cause severe damage to the hydraulic and drive system of the attachment.

GENERAL OPERATING TIPS

STALLING: If the attachment stalls, the operator will have to stop and remove the mulcher from the material and allow the rotor to regain speed. Reduce the load on the mulcher to prevent further stalling.

JAM: When a jam occurs, shut off the hydraulics. Move the mulcher to a clear area. Set the rotor on a log or tree trunk. Apply a small amount of down pressure and slide the mulcher backwards to force the drum to rotate without hydraulics and therefore discharging the jam.

BRUSH: When clearing brush, start at the top and using a sweeping action, swing the unit back and forth through the brush while lowering at a pace that will not decrease the rotor rpm. Once you are completely through the brush, continue sweeping, this will re-mulch the brush and produce a more finished surface.

NOTE: Swinging the mulcher too fast will not properly mulch the material.

CAUTION! Take extra care when mulching dead standing trees. There is a danger of the tops falling back onto the operator's cab, causing injury or property



OPERATION

STANDING TREES: Start at a safe operating height for your prime mover and cut off the top of the tree. Position the mulcher over the tree in such a way that the tree stabilization guide will support the tree and guide it into the rotor, therefore limiting tree deflection and enhancing control and increasing productivity.

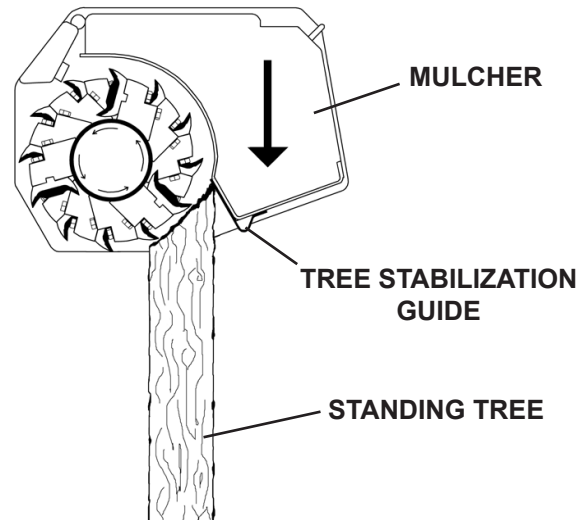

GROUND MULCHING / MIXING: The mulcher head is capable of mulching and mixing debris approximately 1.50" below ground level. Keep in mind that excessive ground engaging will rapidly decrease the life of the cutting teeth, sometimes up to as much as 50%. When doing excessive ground engaged mulching, inspect the cutting teeth more often to prevent wearing the cutters into the holders.

STORAGE

- Clean the unit thoroughly, removing all mud, dirt, and grease.
- Inspect for visible signs of wear, breakage, or damage. Order any parts required and make the necessary repairs to avoid delays upon removal from storage.
- Tighten loose nuts, capscrews and hydraulic connections.
- Seal hydraulic system from contaminants and secure all hydraulic hoses off the ground to help prevent damage.
- Replace decals that are damaged or in unreadable condition.
- Store unit in a dry and protected place. Leaving the unit outside will materially shorten its life.

NOTE: When placing into storage for two months or more, change oil in overhung load adapter. See Maintenance instructions.

Additional Precautions for Long Term Storage:

- Touch up all unpainted surfaces with paint to prevent rust.

REMOVAL FROM STORAGE

- Wash unit and replace any damaged and/or missing parts that were not already replaced.
- Check hydraulic hoses for damage and replace as necessary.

OPERATION

LIFT POINTS

Lifting points are identified by lifting decals where required. Lifting at other points is unsafe and can damage attachment. Do not attach lifting accessories around cylinders or in any way that may damage hoses or hydraulic components.

- Attach lifting accessories to unit at recommended lifting points.
- Bring lifting accessories together to a central lifting point.
- Lift gradually, maintaining the equilibrium of the unit.

WARNING! Use lifting accessories (chains, slings, ropes, shackles and etc.) that are capable of supporting the size and weight of your attachment. Secure all lifting accessories in such a way to prevent unintended disengagement. Failure to do so could result in the attachment falling and causing serious personal injury or death.



TIE DOWN POINTS

Tie down points are identified by tie down decals where required. Securing to trailer at other points is unsafe and can damage attachment. Do not attach tie down accessories around cylinders or in any way that may damage hoses or hydraulic components.

- Attach tie down accessories to unit as recommended.
- Check unit stability before transporting.

WARNING! Verify that all tie down accessories (chains, slings, ropes, shackles and etc.) are capable of maintaining attachment stability during transporting and are attached in such a way to prevent unintended disengagement or shifting of the unit. Failure to do so could result in serious personal injury or death.



TRANSPORTING

Follow all local government regulations that may apply along with recommended tie down points and any equipment safety precautions at the front of this handbook when transporting your attachment.

MAINTENANCE & SERVICE

GENERAL INFORMATION

Regular maintenance is the key to long equipment life and safe operation. Maintenance requirements have been reduced to an absolute minimum. However it is very important that these maintenance functions be performed as described below.

WARNING! Never do any maintenance to the Mulcher while it is running. Exercise the MANDATORY SAFETY SHUTDOWN PROCEDURE BEFORE working on or around the Mulcher.

Procedure	Daily	Every 40 Hours	Every 120 Hours	Every 200 Hours	Every 1000 Hours
Case Drain Coupler - Check for complete engagement of coupler.	✓				
Check for kinked or pinched hoses. Reroute as required.	✓				
Hydraulic Oil - Check prime mover hydraulic system for adequate oil levels.	✓				
Hardware - Check for tightness (see Bolt Torque Specifications)	✓				
Hardware - Replace any missing or damaged bolts or nuts with approved replacement parts.	✓				
Hydraulic System - Check for leaks and tighten as necessary. Check for damage and replace as needed.	✓				
Decals - Check for missing or damaged safety decals and replace as necessary.	✓				
Teeth - Replace worn, damaged or missing teeth.	✓				
Inspect attachment for any worn parts or cracked welds. Repair as required.	✓				
Clean rotor of any accumulated debris and dirt.	✓				
Clean internal mulcher compartments, including drive belt housing area.		✓			
Check drive belt tension.			✓		
Check oil level in overhung load adapter. (See maintenance instructions.)			✓		
Lubricate rotor bearings 2-3 pumps. <i>Over lubricating will cause premature bearing failure.</i>				✓	
Change oil in overhung load adapter. (See maintenance instructions.)					✓

IMPORTANT: When replacing parts, use only factory approved replacement parts. Manufacturer will not claim responsibility for use of unapproved parts or accessories, and/or other damages as a result of their use.

12018 12-15-11

MAINTENANCE & SERVICE

BREAK-IN PERIOD

Procedure	After First 8 Hours	After First 16 Hours	After First 40 Hours	After First 120 Hours
Check drive belt tension.	✓	✓	✓	✓
Check torque on taper-lock bushing set screws. (#113720 to 36 ft. lbs. and #113594 to 84 ft. lbs.)	✓			✓
Change oil in overhung load adapter.				✓

NOTE: Repeat Break-In Period whenever belt, sprockets or overhung load adapter is replaced.

LUBRICATION SPECIFICATIONS

LOWER BEARINGS	NLGI GRADE 2 LITHIUM GREASE WITHOUT GRAPHITE OR MOLYBDENUM ADDITIVES.
OVERHUNG LOAD ADAPTER	SYNTHETIC ISO 150 GEAR LUBE WITHOUT GRAPHITE OR MOLYBDENUM ADDITIVES. (APPROXIMATELY 16 OZ. CAPACITY)

LUBRICATING LOWER BEARINGS

Lubricate lower bearings with 2-3 pumps of grease every 200 hours. Over lubricating will cause premature bearing failure.

NOTE: The right bearing lubrication fitting is located on the top of the drive belt housing compartment along with a grease relief vent plug. The left bearing lubrication fitting is located on the bearing housing along with a grease relief vent plug. Normal pressure build-up during operation may result in grease escaping from relief vent plugs. Continue lubricating at specified intervals.

WARNING! Escaping fluid under pressure can have sufficient force to penetrate the skin, causing serious personal injury. Fluid escaping from a very small hole can be almost invisible. Use a piece of cardboard or wood, rather than hands, to search for suspected leaks.



Keep unprotected body parts, such as face, eyes, and arms as far away as possible from a suspected leak. Flesh injected with hydraulic fluid may develop gangrene or other permanent disabilities.

If injured by injected fluid, see a doctor at once. If your doctor is not familiar with this type of injury, ask him to research it immediately to determine proper treatment.

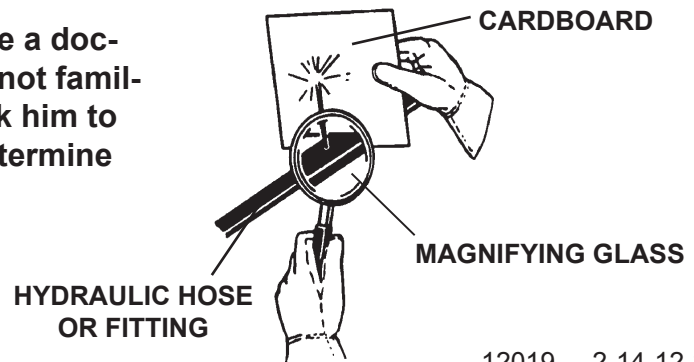

12019 2-14-12-2

MAINTENANCE & SERVICE

WARNING! Before performing maintenance or service lower the attachment to the ground, disengage auxiliary hydraulics, turn off the engine, remove the key and apply the brakes.



WARNING! Never perform any work on this attachment unless you are authorized and qualified to do so. Always read the operator's manuals before any repair is made. After completing maintenance or service, check for correct functioning of the attachment. If not functioning properly, always tag "DO NOT OPERATE" until all problems are corrected.



REPLACING TEETH

Worn, broken or missing teeth will cause excessive machine vibration and reduce productivity. It is important that all teeth are attached properly. Double sided, reversible teeth can be rotated when worn or if carbide points are broken or missing.

1. Remove existing tooth.
2. Check to make sure the mounting surface and bolt holes are clean and free of debris. (Any accumulation of debris can cause the tooth not to seat properly in the slot resulting in unsafe operation.)
3. Position the new tooth onto the holder and after both bolts have been started, push the tooth up into the mounting slot and tighten with an impact wrench. Torque to 150 ft. lbs.

NOTE: Replace any damaged bolts. Always replace lock washers when installing a new tooth. Install washers with the side that is higher in the center towards the bolt head.

NOTICE: Failure to start both bolts into the tooth first before tightening a bolt, can bind the other bolt, and damage the bolt and possibly the cutting tooth, rendering the tooth and bolt unusable.

WARNING! Improper mounting can void warranty and cause serious injury and/or death. Use only manufacturer replacement parts.



DRIVE BELT TENSIONING AND/OR REMOVAL

Due to thermal expansion of the sprockets during operation the belt tension will vary between a cold unit and one that has just been in operation. We recommend checking tension after operation when the belt and sprockets are still warm.

Although there are various ways of checking belt tension we recommend using a single barrel (pencil type) belt tension tester which can be purchased locally.

CAUTION! Due to the hot temperatures of the components when checking the belt tension on a mulcher that has been in operation, gloves are required to prevent personal injury.



CHECKING BELT TENSION

1. Remove the belt tension access cover from the top of the drive housing or the drive belt cover from the side of the drive housing to check belt tension. (Depending on the type of tension tester being used.) See tension chart.
2. If using a pencil type tension tester, insert through hole in top of drive housing compartment and check belt tension. Check belt tension half way between the two sprockets and in the center of the belt. See tension chart.

12020 7-15-14-2

MAINTENANCE & SERVICE

NOTE: Belt tension should be checked in four places evenly spaced around one full rotor rotation. Take the average of the four readings. Test the tension of the belt by checking the deflection in the belt halfway between the two sprockets.

MODELS	NEW BELT		USED BELT (24 + HOURS OF USE)	
	WARM TENSION	COLD TENSION (70°F)	WARM TENSION	COLD TENSION(70°F)
36" MULCHER ASSEMBLY #115620 (28-41 GPM)	73-76 HZ	46-49 HZ	62-66 HZ	39-43 HZ
	.26" Deflection @ 42-45 lbs.	.26" Deflection @ 25-27 lbs.	.26" Deflection @ 35-37 lbs.	.26" Deflection @ 20-23 lbs.
	.1875" Deflection @ 26-28 lbs.	.26" Deflection @ 25-27 lbs.	.1875" Deflection @ 21-23 lbs.	.26" Deflection @ 20-23 lbs.
36" MULCHER ASSEMBLY #115621 (42-60 GPM)	88-92 HZ	56-60 HZ	75-80 HZ	50-55 HZ
	.26" Deflection @ 55-59 lbs.	.26" Deflection @ 30-33 lbs.	.26" Deflection @ 44-48 lbs.	.26" Deflection @ 26-29 lbs.
	.150" Deflection @ 27-29 lbs.	.1875" Deflection @ 18-20 lbs.	.15" Deflection @ 20-22 lbs.	.26" Deflection @ 26-29 lbs.

ADJUSTING BELT TENSION AND/OR REMOVAL

1. Remove the drive belt cover and rear compartment cover.
2. After testing the tension of the belt (See "**CHECKING BELT TENSION**") loosen the two capscrews on the housing seal plate (completely remove seal plate for belt removal) and the four capscrews securing the overhung load adapter to the mainframe.
3. Back off the hex nuts on the top and bottom tensioning bolt. (If adjusting belt tension go to Step #9 . Go to Step #4 to remove drive belt.)

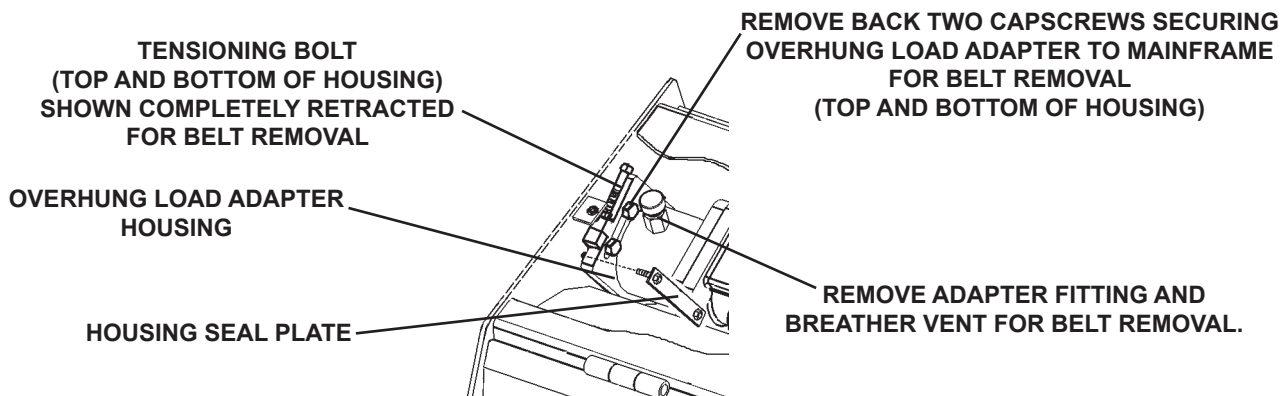

4. Clean area around breather vent and fitting on overhung load adapter assembly. Remove adapter fitting and vent. Plug housing port to prevent contaminants from entering the system.
5. Remove the back two capscrews (one on top and bottom) that secure the overhung load adapter to the mainframe.
6. Back off the hex nuts on the top and bottom tensioning bolts and rotate the tensioning bolts counter-clockwise to allow approximately 1.50" forward travel of the overhung load adapter.
7. Slide overhung load adapter and motor forward to remove tension from drive belt. Remove belt from sprockets. **NOTE: Do not force the drive belt off sprocket flanges as belt damage can occur.**

12021 12-15-11

MAINTENANCE & SERVICE

8. Install new belt and position overhung load adapter and motor to approximate location when belt was tensioned and reinstall the two back capscrews securing the overhung load adapter to the mainframe. Reinstall the breather vent and adapter fitting to the overhung load adapter. Adjust belt tension using cold tension specifications.
9. The two tensioning bolts take a .38" allen wrench to adjust. Adjust the belt tensioning bolts alternately until the proper tension is achieved. Turn the tensioning bolts clockwise to increase belt tension and counter-clockwise to decrease belt tension.
10. Retighten the capscrews securing the overhung load adapter to the mainframe.
11. Recheck belt tension and adjust as required.
12. Once the proper tension has been achieved, torque the capscrews securing the overhung load adapter to the mainframe. Torque to 250 ft. lbs.
13. Check to ensure the tensioning bolts are snug and then tighten the hex nuts.
14. Install the housing seal plate so that it is against the overhung load adapter and tighten capscrews. **NOTE: Housing seal plate is in place to minimize debris from entering the drive belt compartment and therefore reducing belt life.**
15. Install drive belt cover and rear compartment cover using existing hardware.

NOTE: Belt damage can occur if belt is too loose, too tight or if debris is present. Do not operate without drive cover installed.

SPROCKET REMOVAL AND INSTALLATION

TAPER LOCK BUSHING IDENTIFICATION AND ORIENTATION

When replacing sprockets, it is recommended to update both sprockets at the same time.

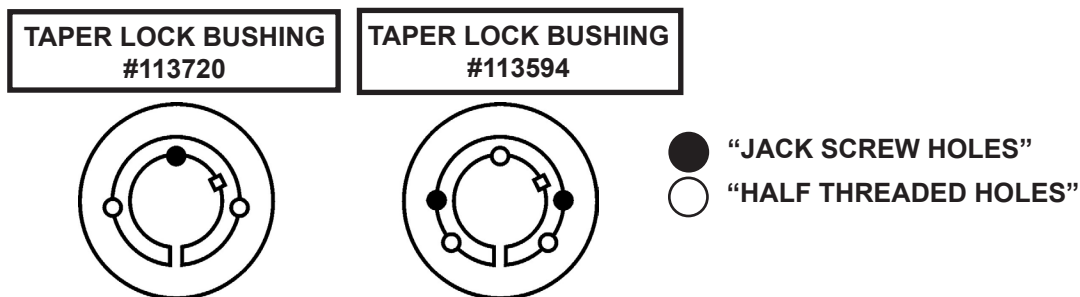

Removal

1. Remove the drive belt. See “**DRIVE BELT TENSIONING AND/OR REMOVAL**”
2. Loosen the taper lock assembly (bushing) in the sprocket by removing all mounting screws.
3. Insert screws into all jack screw holes indicated in the diagram for the Taper Lock Bushing for your mulcher.
4. Loosen the bushing by alternately tightening the screws in small but equal increments until the taper sprocket and bushing surfaces disengage.

Installation

1. Position the overhung load adapter housing, in approximately the same location it was in before the belt was removed, and tighten all four of the .75" capscrews on the overhung load adapter to ensure proper alignment of the shaft and housing.

12022 12-15-11

MAINTENANCE & SERVICE

NOTE: The overhung load adapter housing must be properly seated flat against the mainframe of the mulcher for proper alignment of the sprockets. If there are any gaps along this surface, remove the housing and clean any debris from the surface. Reinstall and tighten.

2. The taper lock bushing assembly needs to be reassembled for proper installation. DO NOT use “Never Seize” on bushing or bolts.
3. Clean the shaft, bore of bushing, outside of bushing and the sprocket hub bore of all oil, paint and dirt. File away any burrs. **NOTE: The use of lubricants can cause sprocket breakage. USE NO LUBRICANTS IN THIS INSTALLATION.**
4. Insert the bushing into the sprocket hub. Match the hole pattern, not the threaded holes (each complete hole will be threaded on one side only.)
5. LIGHTLY oil the set screws and thread them into the half-threaded holes indicated on the diagram.

NOTE: Do not lubricate the bushing taper, hub taper, bushing bore, or the shaft. Doing so could result in sprocket breakage.

NOTE: If both sprockets were removed, install the larger driven sprocket first making sure that it will clear the grease lines and drive belt cover.

6. With the key in the shaft keyway, position the assembly onto the shaft allowing for small (.03” - .06”) axial movement of the sprocket, towards the outside of the unit, which will occur during the tightening process. Make certain the shaft is completely through the bushing.

NOTE: If the locking assembly will not slide onto the shaft, you may have the locking assembly too tight or you may need to drive a wedge into the slot of the taper lock bushing which will therefore increase the bushing bore.

7. Alternately tighten the set screws until the sprocket and taper lock bushing are seated together. Do not apply enough torque to the set screws that the sprocket and taper lock bushing will not slide on the shaft for alignment purposes.

NOTE: Do not use worn hex key wrenches. Doing so may result in a loose assembly or may damage screws.

8. If both sprockets were removed, install the second one using the same procedure.
9. Align the sprockets using a straight edge. The outside edge of both sprockets must be aligned. Torque the set screws to approximately one-half of the recommended torque to lock the bushings onto the shaft. See torque table on the following page. Recheck sprocket alignment.

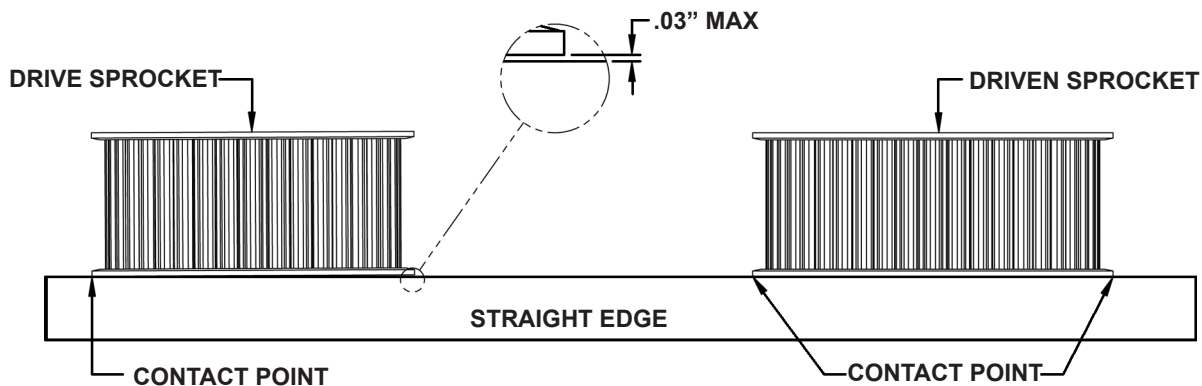

NOTICE: Failure to align the sprockets correctly will decrease the life of the belt.

10. Install the drive belt and tension just enough to prevent the sprockets from rotating.

NOTICE: Never force the belt over the sprocket flange as internal damage to the belt will occur.

12023 12-15-11

MAINTENANCE & SERVICE

11. Continue to alternate tightening of the capscrews on the bushings to the recommended torque value shown in table.
12. To increase the bushing gripping force, hammer the face of the bushing using a drift or sleeve (do not hit the bushing directly with the hammer).
13. Re-torque the bushing screws after hammering.
14. Recheck all screw torque values after the initial drive run-in, and periodically thereafter. Tighten as required.
15. Follow instructions for retensioning the drive belt and cover installation. See “**DRIVE BELT TENSIONING AND/OR REMOVAL**”.

BUSHING	BOLTS		TORQUE WRENCH	
PART NUMBER	QTY	SIZE	LBS - FT.	LBS - IN.
113720	2	.50" UNC X 1.00"	35.8	430
113594	3	.50" UNC X 1.50"	83.3	1000

NOTICE: Excessive bolt torque can cause sprocket and/or bushing breakage.
NOTE: To insure proper bushing/sprocket performance, full bushing contact on the shaft is recommended.

ROTOR REMOVAL AND INSTALLATION

An overhead hoist is required when removing or servicing the rotor.

WARNING!  Before removal of the lower bearing assemblies in preparation of removing or servicing the rotor, disconnect the mulcher from the prime mover and position the mulcher flat on the back or rear compartment.

1. Support the rotor with the overhead hoist.

WARNING!  Use lifting accessories (chains, slings, ropes, shackles and etc.) that are capable of supporting the size and weight of the rotor. Secure rotor in such a way to prevent unintended disengagement. Failure to do so could result in the rotor falling and causing serious personal injury or death.

2. Follow Steps #1 through #8 under “**REPLACING AND/OR SERVICING THE LOWER BEARINGS**”.
3. Remove the right and left skid shoes along with the left side filler plate.
4. Remove the dirt rings by removing the four .25” flat head screws.
5. With the dirt rings free to “float”, begin rotor removal by first gently swinging the left end of the rotor through the slot in the mulcher mainframe. With the left end of rotor free from the mainframe, pull right side of rotor out of mainframe, completely freeing the rotor from the mainframe.

NOTICE: *Be careful not to let rotor shaft ends come into contact with the mainframe which could cause damage to the rotor shaft threads or create dents or burrs in the shaft.*

6. Reverse process for installing the rotor back into the mainframe.
7. Follow Steps #15 and #17 through #25 under “**REPLACING AND/OR SERVICING THE LOWER BEARINGS**”.

MAINTENANCE & SERVICE

CHECKING AND/OR CHANGING OIL IN OVERHUNG LOAD ADAPTER

Before checking, adding or changing the oil in the overhung load adapter, mulcher must be sitting in operating position with skid shoes flat on the ground as shown. See **"LUBRICATION SPECIFICATIONS"** for oil type and capacity.

MULCHER POSITION WITH SKID SHOES FLAT ON GROUND

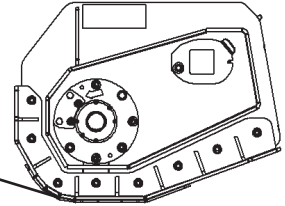

CHECKING AND/OR ADDING OIL

1. Remove rear compartment cover from the back of the mulcher. Clean around the appropriate fill level plug and remove plug. Check to make sure oil level is at fill level plug.

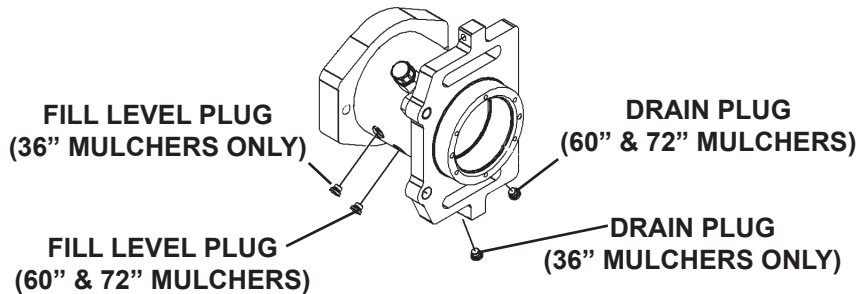

NOTICE: The Overhung Load Adapter assembly is a sealed system. If oil level is low, check all seals for damage.

2. If oil is required, replace fill level plug. Clean around vent breather cap to prevent contaminants from entering the bearing assembly, and remove cap.
3. Add oil. (See Lubrication Specifications)
4. Wait a few minutes to allow oil to settle, filling all voids of the overhung load adapter assembly. Place a container below the fill level plug and remove the fill level plug, allowing all excess oil to drain into the container.

NOTICE: Do not over lubricate the overhung load adapter assembly as this will cause excess heat generation and all excess oil will be purged from the breather cap.

5. Replace fill level plug, vent breather cap and rear compartment cover.

CHANGING OIL

To maximize the life of the overhung load adapter bearings, it is recommended to change oil after the initial 120 hours of operation of a new mulcher or replacement overhung load adapter assembly. Follow Maintenance schedule after the break in period as oil will break down over time.

MAINTENANCE & SERVICE

NOTICE: Oil should be drained while it is warm and therefore has a low viscosity. If changing oil after the mulcher has been in operation, allow time for the oil AND housing to cool down. If changing oil prior to operating, engage mulcher hydraulics at a low engine idle and run for approximately 5 minutes to warm the oil. Take extra precautions to avoid burns when doing maintenance on a mulcher after it has been in operation. Components can be very hot.

1. Remove rear compartment cover.
2. Clean around the appropriate drain plug and vent breather cap and then remove the vent breather cap. (Removing the vent breather cap will allow the oil to drain faster.)
3. Place a container under the drain plug to catch the oil and then remove the drain plug. Allow time for all oil to drain from the overhung load adapter and then reinstall the drain plug.
4. Add approximately 16 oz. of recommended oil (See Lubrication Specifications). Wait a few minutes to allow oil to settle, filling all voids of the overhung load adapter assembly. Place a container below the fill level plug and remove the fill level plug, allowing all excess oil to drain into the container.

NOTICE: Do not over lubricate the overhung load adapter assembly as this will cause excess heat generation and all excess oil will be purged from the breather cap.

5. Replace fill level plug, vent breather cap and rear compartment cover.

REPLACING SKID SHOE WEAR PADS

The weld-on wear pads on your mulcher left and right skid shoe is replaceable. Refer to the parts diagram for your mulcher to order replacement wear pads.

1. Position the mulcher in a well ventilated area and remove the skid shoe(s) from the mainframe.
2. Remove any existing wear pad that is still on the skid shoe along with any paint that is around the weld area. Follow all safety precautions listed in the front of this manual for removing paint before welding.
3. Position the new wear pad onto the skid shoe. Place a .25" weld at the locations shown on the diagram below.
4. Prime and paint the new wear pad and skid shoe.
5. Reinstall skid shoe onto mainframe using existing hardware.

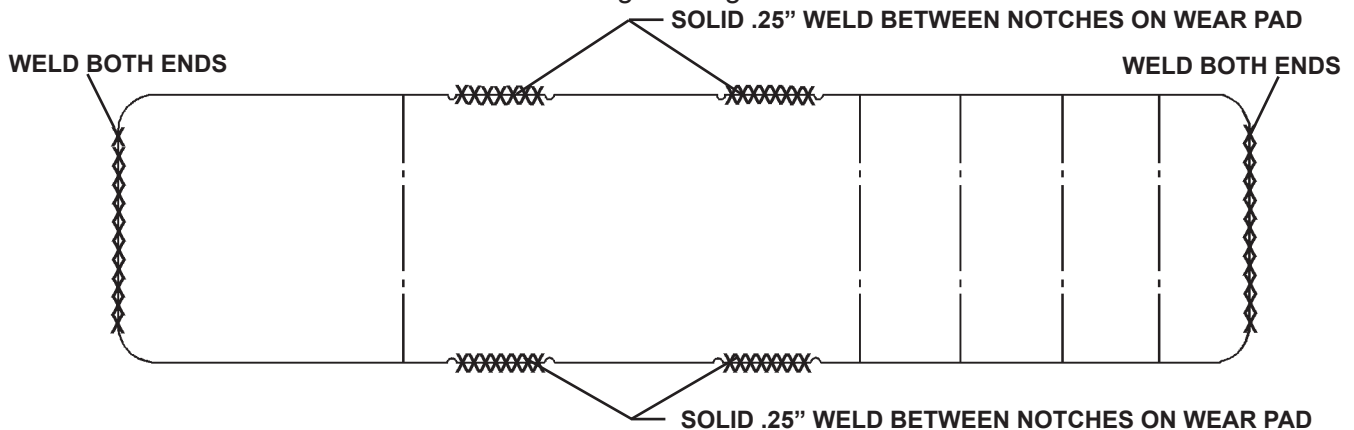

MAINTENANCE & SERVICE

QUALIFIED TECHNICIAN MAINTENANCE

WARNING! Before performing maintenance or service, lower the attachment to the ground, disengage auxiliary hydraulics, turn off the engine, remove the key and apply the brakes.



WARNING! Never perform any work on this attachment unless you are authorized and qualified to do so. Always read the operator's manual before any repair is made. After completing maintenance or service, check for correct functioning of the attachment. If not functioning properly, always tag "DO NOT OPERATE" until all problems are corrected.



REPLACING AND/OR SERVICING THE LOWER BEARINGS

An overhead hoist and the optional bearing socket assembly #116125 is recommended when servicing the lower bearing assemblies.

1. Remove the drive belt. (Right side bearing only.) See "DRIVE BELT TENSIONING AND/OR REMOVAL"
2. Remove the lower sprocket on rotor shaft. (Right side bearing only.) See "SPROCKET REMOVAL AND INSTALLATION".
3. Disconnect grease line (A) and relief line (B). (Right side bearing only.) (Push gray extrusions on straight connector's (C) inward while pulling hose lines outward.) Plug or cap fittings and hoses to prevent contaminants from entering the lubrication system.
4. Remove the four socket head capscrews (D) and the outer seal cap (E). (You may have to install two of the socket head capscrews into the push off holes (F) to remove the outer seal cap.)
5. Clean any visible grease from the lower bearing assembly.
6. Remove the bearing lock nut (G) and bearing lock washer (H).

RIGHT LOWER BEARING ASSEMBLY

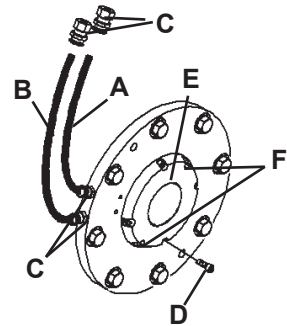

LOCKING TAB - BENT OUT

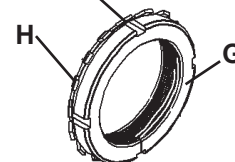

NOTE: Be sure the rotor is properly supported before lower bearing removal. The locking tab must be bent out of the bearing lock nut (G) prior to removal of the nut. Failure to bend out the locking tab can result in damaging the locking washer (H).

7. It is recommended to use the bearing lock nut provided in the bearing socket assembly #116125 to remove the withdrawal sleeve (I) which is locking the bearing (J) to the rotor shaft. Install the bearing lock nut (K) with the chamfer side of the lock nut towards the bearing to prevent damage. Tighten the lock nut (K) onto the withdrawal sleeve (I) using the bearing socket and a .75" drive ratchet or breaker bar to "pull" the withdrawal sleeve out of the bearing inner race. Do not completely remove the withdrawal sleeve from the bearing.

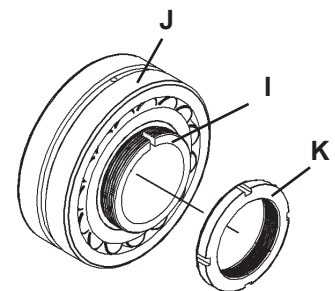

MAINTENANCE & SERVICE

QUALIFIED TECHNICIAN MAINTENANCE

8. Remove the eight .50" capscrews from the bearing housing (L) and install two of them into the push off holes to aid in the removal of the bearing housing. Remove the bearing housing.
NOTE: When removing the capscrews on the left lower bearing housing the grease fitting protection guard will also be removed.
9. Remove the ten socket head capscrews from the inner seal cap (M) and remove the inner seal cap and spacer ring (N - right side bearing only). **NOTE: Two of the capscrews may need to be installed into the push off holes in the inner seal cap for removal.**
10. Slide or press the bearing out the back of the housing (L).
11. Inspect the inside of the bearing housing, the withdrawal sleeve and rotor shaft for defects, such as burrs, worn surfaces or any surface imperfections. Inspect the rotor shaft seals for damage.
NOTE: It is recommended to replace rotor shaft seals when replacing bearings.

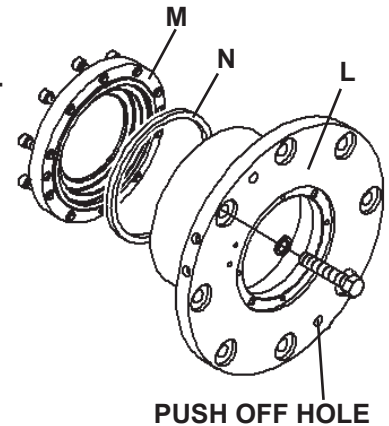

LOWER RIGHT BEARING IDENTIFICATION



NOTICE: Although the left and right bearings look alike they are different. Be sure to identify and install the correct bearing during replacement. The right side bearing #600-158 will have a "C3" on the bearing rim while the left bearing #115439 will not. All other identification marks, letters and numbers are related to manufacturer and do not have any significance in distinguishing between the two bearings. Take extra care to install the correct bearing into the correct housing. The right bearing housing will have the grease and relief ports on the outside flange diameter of the housing while the left side bearing housing will have the grease and relief ports on the outside flange face of the bearing housing.

12. Clean all lower bearing components and rotor shaft, removing all grease and contaminants. Apply a light coat of machine oil to the inside of the bearing housing and install the new bearing with the smaller side of the taper in the bearing inner race to the inside of the housing. Check diagram for correct bearing orientation.
 - a. Position the bearing as straight as possible with the bearing housing.
 - b. Position a tube over the bearing, contacting the outer race of the bearing only, and lightly tap until the bearing is aligned with the housing.
 - c. Once alignment has been achieved the left side bearing will easily slide into place while the right side bearing will need a press. Ensure right bearing is fully seated into the housing.

NOTE: Apply force to the outer race of the bearing only to prevent damage.

MAINTENANCE & SERVICE

QUALIFIED TECHNICIAN MAINTENANCE

13. Pack the bearings with grease and install the bearing spacer ring (right lower bearing assembly only).
14. Apply a light film of grease to the inside of both seal cap shaft seal bores and install the rotor shaft seals.

NOTE: Apply force to the outer rim of the rotor shaft seals to prevent seal damage.

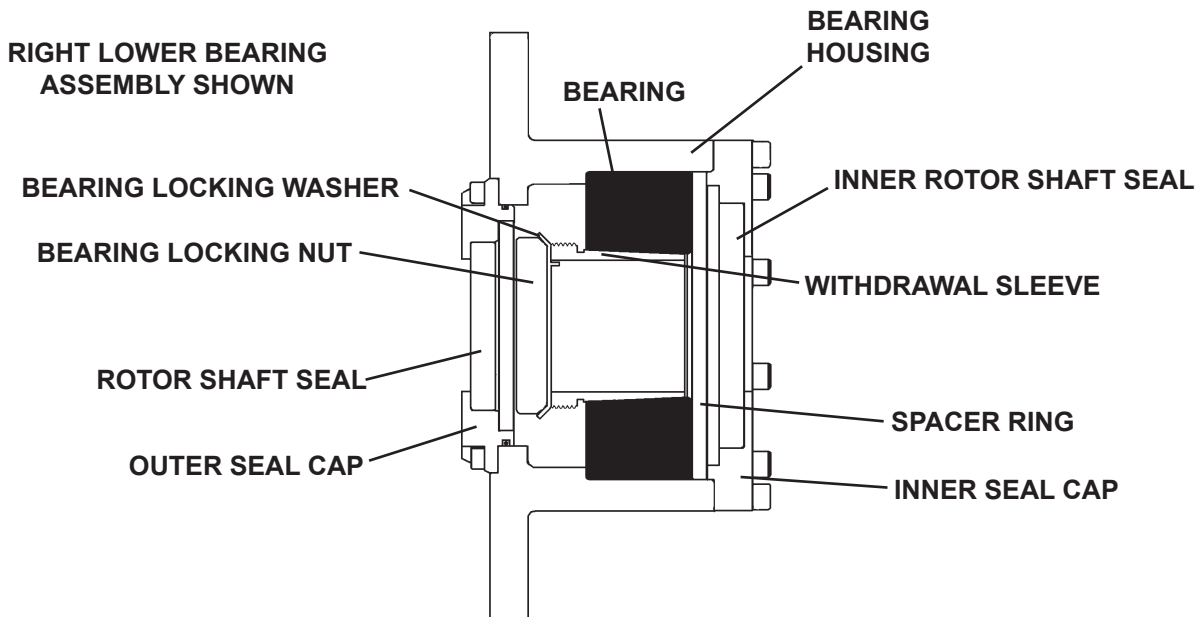

15. Apply light film of grease between the dual lips of the inner rotor shaft seals and on the rotor shaft itself where the shaft seal will be located taking extra care not to apply too much. Excessive grease will be wiped off of the seal during installation onto the rotor shaft and become trapped between the bearing inner race and the shoulder on the rotor shaft. This can wear away during operation resulting in a loose bearing.
16. Position the inner seal cap onto the housing with the push off holes aligned with the counter bore holes in the housing to prevent damage during future maintenance. Install the inner seal cap using the existing capscrews and loctite 271. Torque to 25 ft. lbs.
17. Clean the inner bore surfaces of the bearing of all protective oil coating and apply a light coat of machine oil to the inner race of the bearing and all surfaces of withdrawal sleeve and rotor shaft. Loosely install the withdrawal sleeve into the bearing.
18. Position the bearing assembly onto the rotor shaft and secure in place using the existing .50" hardware and loctite 271. Check that the left and right lower bearing assemblies are correctly oriented and that the grease fitting guard is reinstalled onto the left lower bearing assembly with the 3.00" long capscrews. Torque all capscrews to 80 ft. lbs.
19. Install the bearing lock washer. Apply a coat of machine oil to the threads on the bearing lock nut and install the lock nut onto the rotor shaft. Lightly torque to approximately 50 ft. lbs.

MAINTENANCE & SERVICE

QUALIFIED TECHNICIAN MAINTENANCE

NOTE: Tighten the right side bearing lock nut first since it provides axial location of rotor.

20. RIGHT LOWER BEARING ASSEMBLY - ONLY

Torque bearing lock nut to 400 ft. lbs.

A bearing lock washer tab must align with a slot in bearing lock nut.

It is recommended to check internal radial clearance of bearings with a feeler gauge.

- Rotate rotor several times to seat bearing rollers. Right side bearing should be mounted with minimum 0.0015" of internal radial clearance.
- Using a feeler gauge, insert a 0.0015" blade between two unloaded rollers at top of bearing. Rotate rotor until blade is over a roller. The feeler gauge blade should pull out with minimal force. Continue to rotate rotor and check in four different places.
- If feeler gauge blade cannot be pulled from bearing at all four locations the bearing lock nut is too tight. Remove bearing lock nut and pull withdrawal sleeve out slightly. Repeat process at less torque. **NOTE: if a minimum of 300 ft. lbs. of torque cannot be achieved, contact factory.**
- Remember a bearing lock washer tab must align with a slot in bearing lock nut.

CHECK FOR RECOMMENDED INTERNAL RADIAL CLEARANCE AT TOP OF BEARING

INSERT FEELER GAUGE BLADE HERE AND ROTATE BEARING TO CHECK FOR RECOMMENDED CLEARANCE.

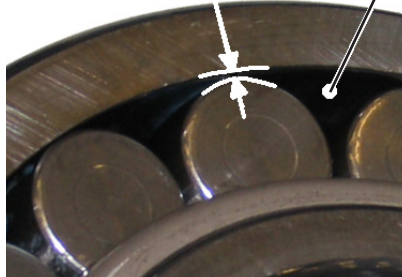

20. LEFT LOWER BEARING ASSEMBLY - ONLY

Torque bearing lock nut to 500 ft. lbs.

A bearing lock washer tab must align with a slot in bearing lock nut.

Check gap between bearing and shoulder on left lower bearing housing. A gap of .13" min. to .53" max. should remain to allow for thermal expansion and contraction of rotor shaft.

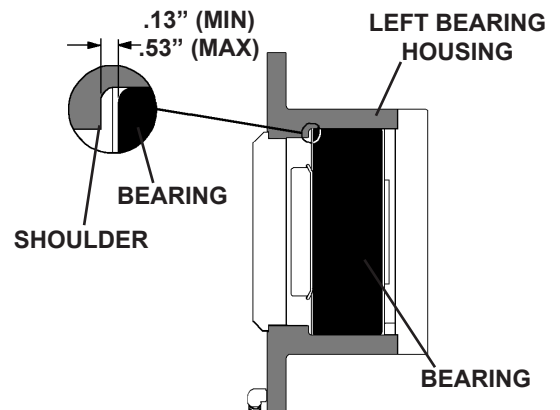

12030 2-14-12-2

MAINTENANCE & SERVICE

QUALIFIED TECHNICIAN MAINTENANCE

It is recommended to check internal radial clearance of bearings with a feeler gauge.

- a. Rotate rotor several times to seat bearing rollers. Left side bearing should be mounted with minimum 0.0010" of internal radial clearance.
 - b. Using a feeler gauge, insert a 0.0010" blade between two unloaded rollers at top of bearing. Rotate rotor until blade is over a roller. The feeler gauge blade should pull out with minimal force. Continue to rotate rotor and check in four different places.
 - c. If feeler gauge blade cannot be pulled from bearing at all four locations, the bearing lock nut is too tight. Remove bearing lock nut and pull withdrawal sleeve out slightly. Repeat process at less torque. **NOTE: if a minimum of 400 ft. lbs. of torque cannot be achieved, contact factory.**
 - d. Remember a bearing lock washer tab must align with a slot in bearing lock nut.
21. Remove rotor supports. After verifying that rotor spins freely, bend lock washer tab over to lock bearing lock nut in place. Never back the bearing lock nut off to align lock washer tab, always tighten bearing lock nut to achieve tab alignment.
22. Reconnect the relief and grease lines (right lower bearing assembly only). Pump grease into the bearing assemblies to be sure grease is coming out through the rollers of the bearing.

NOTE: Use NLGI Grade 2 Lithium grease only. Grease must not contain any graphite or molybdenum additives which will cause premature bearing failure.

23. With outer seal cap removed, pump grease into bearing housing until it is approximately half full. Do not over grease since this will cause excess heat generation during operation.
24. Apply a light film of grease to o'ring and install on outer seal cap. Pack grease between dual lips of shaft seal. Install outer seal cap onto bearing assembly.

NOTE: Push off holes in the outer seal cap should be aligned with counter bore holes in housing to prevent damage to housing during future maintenance. Secure in place using existing .25" sockethead capscrews and loctite 271. Torque to 12 ft. lbs.

25. **Right Lower Bearing Assembly:** Reinstall the belt, sprocket & covers following the belt and sprocket installation procedure.

REPLACING AND/OR SERVICING THE OVERHUNG LOAD ADAPTER AND HYDRAULIC MOTOR

NOTE: An overhead hoist is recommended when removing the hydraulic motor and overhung load adapter assembly.

NOTICE: Due to the complexity of servicing the drive shaft, bearings and housing, these parts are not replaceable. Hydraulic motor and overhung load adapter maintenance and service is limited to replacing the gasket, seals and o'rings. All other field service will void warranty.

REMANUFACTURED OVERHUNG LOAD ADAPTERS ARE AVAILABLE FROM THE FACTORY. (PART #115443R) CONTACT CUSTOMER SERVICE FOR DETAILED INSTRUCTIONS. DO NOT DISASSEMBLE.

MAINTENANCE & SERVICE

QUALIFIED TECHNICIAN MAINTENANCE

REMOVAL - OVERHUNG LOAD ADAPTER

1. Remove the drive belt. See “**DRIVE BELT TENSIONING AND/OR REMOVAL**”
2. Securely attach hoist to the motor and overhung load adapter housing to support it for removal.
3. Remove the upper sprocket. See “**SPROCKET REMOVAL AND INSTALLATION**”.
4. Tag and remove hoses from the hydraulic motor. Cap or plug hoses and fittings to prevent contaminants from entering the hydraulic system.
5. Remove the .75” capscrews securing the overhung load adapter to the side of the mulcher mainframe.
6. Slide the motor and housing assembly out of the mulcher mainframe. Drain oil from housing by removing the appropriate plug for your mulcher.
7. Place overhung load adapter housing and motor assembly on a clean surface. Remove the capscrews securing the motor to the housing and separate the housing from the motor.
8. Remove motor o’ring and inspect for damage. Replace as required.
9. Inspect motor shaft seal for damage and replace as required.

NOTE: Field service of internal motor seals will void warranty.

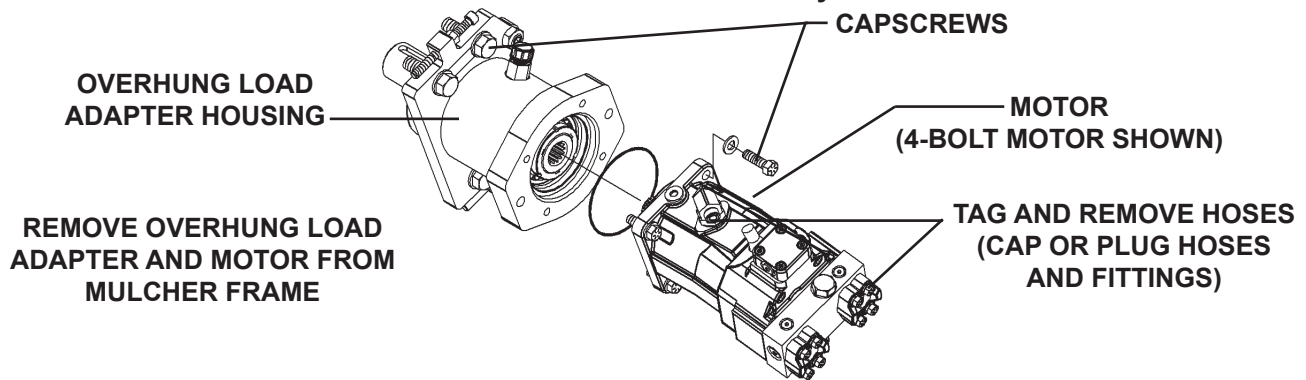

IMPORTANT: If installing a remanufactured overhung load adapter, the old overhung load adapter assembly must be returned to the factory with the seal cap removed from the remanufactured assembly and installed on the assembly to be returned to receive maximum credit.

INSTALLATION - OVERHUNG LOAD ADAPTER

1. After replacing motor o’ring and/or seals (if required) install overhung load adapter over the output shaft on the hydraulic motor and reinstall the existing capscrews. Torque .62” capscrews (2-bolt flange) to 250 ft. lbs. and .50” capscrews (4-bolt flange) to 100 ft. lbs.
2. Using an overhead hoist, install motor and overhung load adapter assembly into mulcher mainframe using the existing front two .75” capscrews and washers.
3. Install upper sprocket and drive belt. See “**SPROCKET REMOVAL AND INSTALLATION**”.
4. Fill overhung load adapter assembly with oil. All adapter assemblies are shipped from factory without oil. See “**LUBRICATION SPECIFICATIONS**”.
5. Reconnect hydraulic hoses to motor. Torque manifold/hose clamp capscrews to 30 ft. lbs. (55CC motor) or 45 ft. lbs. (80CC motor).

OVERHUNG LOAD ADAPTER SEAL REPLACEMENT

1. Remove the drive belt. See “**DRIVE BELT TENSIONING AND/OR REMOVAL**”
2. Remove the upper sprocket. See “**SPROCKET REMOVAL AND INSTALLATION**”.
3. Drain oil from housing by removing the appropriate plug for your mulcher.

12032 12-15-11

MAINTENANCE & SERVICE

QUALIFIED TECHNICIAN MAINTENANCE

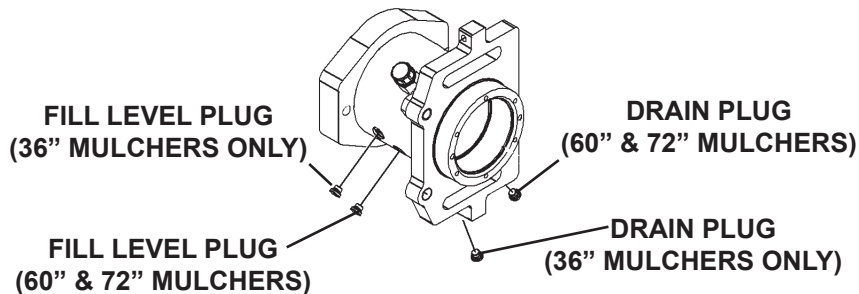

4. After ensuring that the capscrews securing the retaining seal cap to the overhung load adapter remain at 25 ft. lbs., check the gap between the retaining seal cap and the adapter housing between capscrews using a feeler gauge. This gap should be between 0.0015" and 0.010".
5. Remove the retaining seal cap. To assist in removal, two capscrews may be installed into the push off holes in the retaining seal cap.
6. If a minimum gap of 0.0015" did not exist between the retaining seal cap and bearing housing inspect the bearing for signs of "creeping". If any signs of bearing creep have been detected, the retaining seal cap should be replaced.

NOTE: When the bearing is trying to "creep" out of its normal location and pushing out on the retaining seal cap, there will be signs of wear on the outer rim of the bearing where it comes into contact with the retaining seal cap.

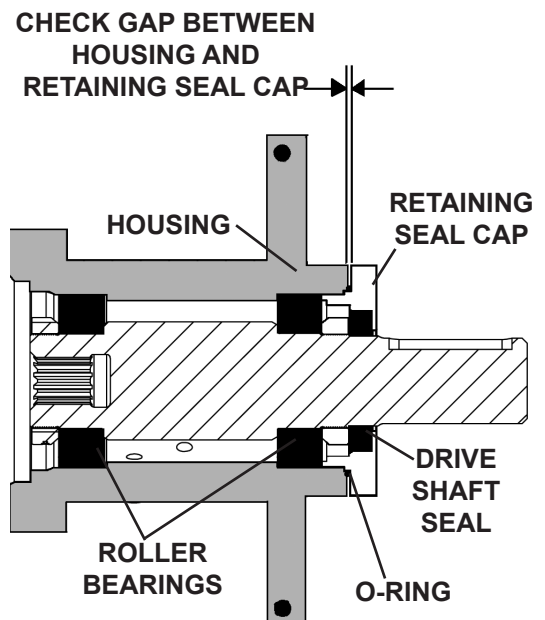

7. Remove drive shaft seal from the retaining seal cap and inspect o'ring for damage. Replace as required.
8. Lubricate drive shaft seal bore of retaining seal cap with light film of grease and install new drive shaft seal.

NOTE: Apply force to the outer rim of the drive shaft seal to prevent seal damage.

9. Lubricate o'ring with a light film of grease and install into retaining seal cap.
10. Apply grease to the dual lips of the drive shaft seal and install retaining seal cap onto overhung load adapter assembly. Be careful to not "roll" lips of drive shaft seal during installation.

NOTE: Push off holes in the retaining seal cap should be aligned with counter bore holes in housing to prevent damage to housing during future maintenance. Secure in place using existing .31" sockethead capscrews and loctite 271. Torque to 25 ft. lbs.

11. Repeat step #4 to assure a minimum gap of 0.0015" and a maximum gap of 0.010" remains.
12. Install upper sprocket and drive belt. See "SPROCKET REMOVAL AND INSTALLATION".
13. Fill overhung load adapter assembly with oil. See "LUBRICATION SPECIFICATIONS".
14. Replace all covers.

TROUBLESHOOTING

PROBLEM	POSSIBLE CAUSE	POSSIBLE REMEDY
Rotor not turning.	Auxiliary hoses not hooked up to the prime mover.	Check coupler engagement.
	Obstruction in hydraulic lines.	Remove obstruction. Replace if necessary.
	Hydraulic motor damaged or seals blown.	Call Bradco service department for instructions.
	Auxiliary control valve not engaged.	Verify hydraulic flow using inline flow meter or other attachment.
	Rocks and debris caught between rotor and mainframe.	Remove debris. (See "General Operating Tips")
	Damaged quick coupler.	Replace if necessary.
	Drive belt broken.	Replace if necessary.
	Auxiliary hoses not hooked up correctly.	Reverse hoses to prime mover.
	Check valve cartridge in hydraulic motor manifold block is damaged.	Inspect and replace if necessary.
Rotor rotates sluggishly.	Insufficient hydraulic flow from the prime mover.	Refer to prime mover owners manual and verify hydraulic flow using an inline flow meter or other attachment.
	Damaged quick coupler.	Replace if necessary.
	Hydraulic motor damaged or seals blown.	Call Bradco service department for instructions.
	Oil or fuel filter on prime mover needs replaced.	Refer to prime mover owners manual.
	Check valve cartridge in hydraulic motor manifold block is damaged.	Replace if necessary.
	Relief valve setting on mulcher adjusted too low. <i>(Refer to prime mover owners manual for relief pressure of prime mover. Relief pressure on mulcher should be higher. Prime mover should always relieve pressure before the mulcher.)</i>	Check pressure at hydraulic motor with a pressure gauge at #4 port on pressure side of hydraulic manifold block. Replace if necessary.

TROUBLESHOOTING

PROBLEM	POSSIBLE CAUSE	POSSIBLE REMEDY
Insufficient power.	Insufficient hydraulic flow from the prime mover.	Refer to prime mover owners manual and verify hydraulic flow using an inline flow meter or other attachment.
	Relief valve setting on prime mover adjusted too low.	Refer to prime mover owners manual.
	Hydraulic motor damaged or seals blown.	Call Bradco service department for instructions.
	Oil or fuel filter on prime mover needs replaced.	Refer to prime mover owners manual.
	Incorrect motor displacement setting.	Reset motor displacement for your prime mover. See Set-Up Instructions.
	Damaged quick coupler.	Replace if necessary.
	Check valve cartridge in hydraulic motor manifold block is damaged.	Inspect and replace check valve if necessary.
	Relief valve setting on mulcher adjusted too low. <i>(Refer to prime mover owners manual for relief pressure of prime mover. Relief pressure on mulcher should be higher. Prime mover should always relieve pressure before the mulcher.)</i>	Check pressure at hydraulic motor with a pressure gauge at #4 port on pressure side of hydraulic manifold block. Replace if necessary.
Excessive oil temperature.	Hydraulic oil level too low.	Refer to prime mover owners manual.
	Obstruction in hydraulic lines.	Remove obstruction and replace if necessary.
	Hydraulic oil or oil filter in prime mover needs replaced.	Refer to prime mover owners manual.
	Relief valve setting on prime mover adjusted too low.	Refer to prime mover owners manual.
	Obstructed radiator/cooler on prime mover.	Clean radiator/cooler.
	Incorrect motor displacement setting.	Reset motor displacement for your prime mover. See Set-Up Instructions.
	Operating the mulcher at maximum pressure for an extended amount of time.	Slow down the speed and/or the down pressure on the mulcher until operating below maximum pressure.
	Relief valve setting on mulcher adjusted too low. <i>(Refer to prime mover owners manual for relief pressure of prime mover. Relief pressure on mulcher should be higher. Prime mover should always relieve pressure before the mulcher.)</i>	Check pressure at hydraulic motor with a pressure gauge at #4 port on pressure side of hydraulic manifold block. Replace if necessary.

TROUBLESHOOTING

PROBLEM	POSSIBLE CAUSE	POSSIBLE REMEDY
Leaking Oil.	Loose or damaged hydraulic line.	Tighten or replace.
	Upper bearing failure.	Replace if necessary.
	O-Rings on hydraulic fittings damaged.	Replace if necessary.
	Hydraulic motor damaged or seals blown.	Call Bradco service department for instructions.
	Hydraulic fittings loose or damaged.	Tighten or replace.
	Case drain not properly connected or coupler damaged.	Engage coupler or replace.
	Case drain hose pinched.	Check hose routing and adjust if necessary.
Excessive vibration during operation.	Teeth are worn, broken or missing.	Inspect and replace if necessary.
	Bearing failure.	Inspect and replace if necessary.
	Rotor obstruction.	Clear all debris from rotor and teeth. (See General Operating Tips)
	Incorrect tensioning of belt.	Retension belt. See Belt Tensioning.
Excessive or uneven tooth wear on drive belt	Incorrect tensioning of belt.	Retension belt. See Belt Tensioning.
	Sprockets misaligned.	Align sprockets using a straight edge.
	Sprockets worn.	Replace if necessary.
	Debris in drive assembly.	Remove debris and replace covers.
Drive belt skipping or ratcheting.	Belt undertensioned.	Retension belt. See Belt Tensioning.
	Sprocket worn.	Replace worn sprocket.
	Debris in drive assembly.	Remove debris and replace covers.
	Insufficient warm up time.	Follow correct warm up procedure.
Drive belt cracking.	Excessive low temperatures.	Moderate temperatures, especially at start up.
	Exposed to oil solvents/chemicals.	Eliminate exposure to chemicals and shield drive.
	Incorrect tensioning of belt.	Retension belt. See Belt Tensioning.
	Sprockets misaligned.	Align sprockets using straight edge.



BOLT TORQUE SPECIFICATIONS

GENERAL TORQUE SPECIFICATION TABLES

Use the following charts when determining bolt torque specifications when special torques are not given. Always use grade 5 or better when replacing bolts.



SAE BOLT TORQUE SPECIFICATIONS

NOTE: The following torque values are for use with extreme pressure lubricants, plating or hard washer applications. Increase torque 15% when using hardware that is unplated and either dry or lubricated with engine oil.

Bolt Size		SAE GRADE 5 TORQUE				SAE GRADE 8 TORQUE				Bolt head identification marks as per grade. NOTE: Manufacturing Marks Will Vary
		Pounds Feet		Newton-Meters		Pounds Feet		Newton-Meters		
Inches	Millimeters	UNC	UNF	UNC	UNF	UNC	UNF	UNC	UNF	
1/4	6.35	8	9	11	12	10	13	14	18	<p>GRADE 2</p>  <p>GRADE 5</p>  <p>GRADE 8</p> 
5/16	7.94	14	17	19	23	20	25	27	34	
3/8	9.53	30	36	41	49	38	46	52	62	
7/16	11.11	46	54	62	73	60	71	81	96	
1/2	12.70	68	82	92	111	94	112	127	152	
9/16	14.29	94	112	127	152	136	163	184	221	
5/8	15.88	128	153	174	207	187	224	254	304	
3/4	19.05	230	275	312	373	323	395	438	536	
7/8	22.23	340	408	461	553	510	612	691	830	
1	25.40	493	592	668	803	765	918	1037	1245	
1-1/8	25.58	680	748	922	1014	1088	1224	1475	1660	
1-1/4	31.75	952	1054	1291	1429	1547	1700	2097	2305	
1-3/8	34.93	1241	1428	1683	1936	2023	2312	2743	3135	
1-1/2	38.10	1649	1870	2236	2535	2686	3026	3642	4103	

METRIC BOLT TORQUE SPECIFICATIONS

NOTE: The following torque values are for use with metric hardware that is unplated and either dry or lubricated with engine oil. Reduce torque 15% when using hardware that has extreme pressure lubricants, plating or hard washer applications.

Bolt head identification marks as per grade.		
		

Size of Bolt	Grade No.	Pitch (mm)	Pounds Feet	Newton-Meters	Pitch (mm)	Pounds Feet	Newton-Meters
M6	5.6	1.0	3.6-5.8	4.9-7.9	-	-	-
	8.8		5.8-4	7.9-12.7		-	-
	10.9		7.2-10	9.8-13.6		-	-
M8	5.6	1.25	7.2-14	9.8-19	1.0	12-17	16.3-23
	8.8		17-22	23-29.8		19-27	25.7-36.6
	10.9		20-26	27.1-35.2		22-31	29.8-42
M10	5.6	1.5	20-25	27.1-33.9	1.25	20-29	27.1-39.3
	8.8		34-40	46.1-54.2		35-47	47.4-63.7
	10.9		38-46	51.5-62.3		40-52	54.2-70.5
M12	5.6	1.75	28-34	37.9-46.1	1.25	31-41	42-55.6
	8.8		51-59	69.1-79.9		56-68	75.9-92.1
	10.9		57-66	77.2-89.4		62-75	84-101.6
M14	5.6	2.0	49-56	66.4-75.9	1.5	52-64	70.5-86.7
	8.8		81-93	109.8-126		90-106	122-143.6
	10.9		96-109	130.1-147.7		107-124	145-168
M16	5.6	2.0	67-77	90.8-104.3	1.5	69-83	93.5-112.5
	8.8		116-130	157.2-176.2		120-138	162.6-187
	10.9		129-145	174.8-196.5		140-158	189.7-214.1
M18	5.6	2.0	88-100	119.2-136	1.5	100-117	136-158.5
	8.8		150-168	203.3-227.6		177-199	239.8-269.6
	10.9		175-194	237.1-262.9		202-231	273.7-313
M20	5.6	2.5	108-130	146.3-176.2	1.5	132-150	178.9-203.3
	8.8		186-205	252-277.8		206-242	279.1-327.9
	10.9		213-249	288.6-337.4		246-289	333.3-391.6

SPECIFICATIONS

36" MULCHERS

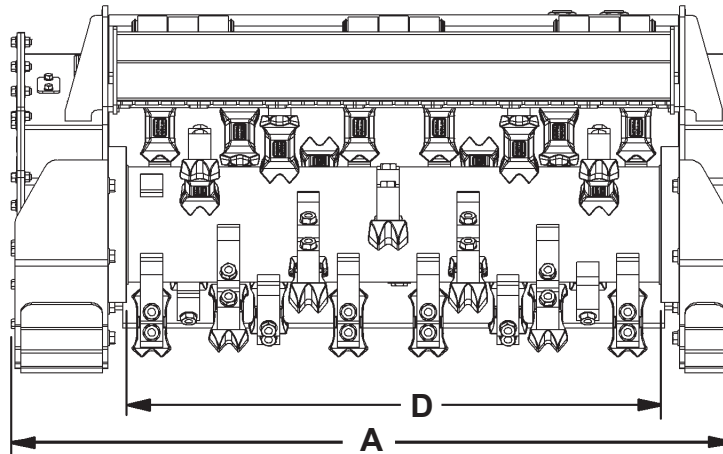
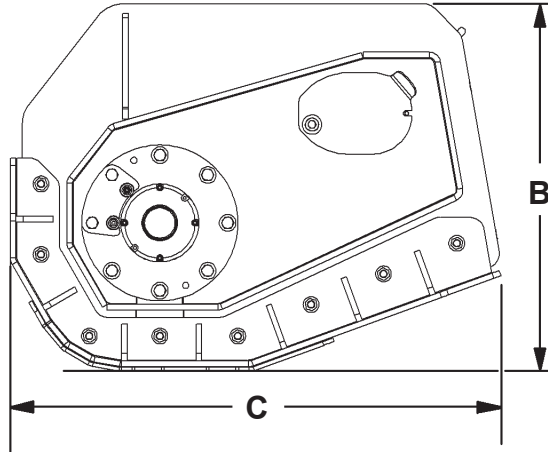

DESCRIPTION	115620	115621
A. Overall Width	48.50"	48.50"
B. Overall Height	24.75"	24.75"
C. Overall Length	33.03"	33.03"
D. Cutting Width	36.00"	36.00"
Operating Pressure (PSI)	3500-5000	3500-5000
Hydraulic Flow (GPM)	28-41	42-60
Required Hydraulic Horsepower (HP)	40-65	65-90
Number of Teeth	26	26
Weight (LBS)	1580#	1600#

Specifications and design are subject to change without notice and without liability therefor.

Limited Warranty

Except for the Excluded Products as described below, all new products are warranted to be free from defects in material and/or workmanship during the Warranty Period, in accordance with and subject to the terms and conditions of this Limited Warranty.

1. Excluded Products. The following products are excluded from this Limited Warranty:

(a) Any cable, part that engages with the ground (i.e. sprockets), digging chain, bearing, teeth, tamping and/or demolition head, blade cutting edge, pilot bit, auger teeth and broom brush that either constitutes or is part of a product.

(b) Any product, merchandise or component that, in the opinion of Paladin Light Construction¹, has been (i) misused; (ii) modified in any unauthorized manner; (iii) altered; (iv) damaged; (v) involved in an accident; or (vi) repaired using parts not obtained through Paladin Light Construction.

2. Warranty Period. The Limited Warranty is provided only to those defects that occur during the Warranty Period, which is the period that begins on the first to occur of: (i) the date of initial purchase by an end-user, (ii) the date the product is first leased or rented, or (iii) the date that is six (6) months after the date of shipment by Paladin Light Construction as evidenced by the invoiced shipment date (the "Commencement Date") and ends on the date that is twelve (12) months after the Commencement Date.

3. Terms and Conditions of Limited Warranty. The following terms and conditions apply to the Limited Warranty hereby provided:

(a) Option to Repair or Replace. Paladin Light Construction shall have the option to repair or replace the product.

(b) Timely Repair and Notice. In order to obtain the Limited Warranty, (i) the product must be repaired within thirty (30) days from the date of failure, and (ii) a claim under the warranty must be submitted to Paladin Light Construction in writing within thirty (30) days from the date of repair.

(c) Return of Defective Part or Product. If requested by Paladin Light Construction, the alleged defective part or product shall be shipped to Paladin Light Construction at its manufacturing facility or other location specified by Paladin Light Construction, with freight PRE-PAID by the claimant, to allow Paladin Light Construction to inspect the part or product.

Claims that fail to comply with any of the above terms and conditions shall be denied.

LIMITATIONS AND EXCLUSIONS.

THIS LIMITED WARRANTY IS IN LIEU OF ALL OTHER WARRANTIES, EXPRESS OR IMPLIED, INCLUDING WITHOUT LIMITATION THE WARRANTIES OF MERCHANTABILITY, FITNESS FOR A PARTICULAR PURPOSE AND ANY WARRANTY BASED ON A COURSE OF DEALING OR USAGE OF TRADE.

IN NO EVENT SHALL PALADIN LIGHT CONSTRUCTION BE LIABLE FOR CONSEQUENTIAL OR SPECIAL DAMAGES.

IN NO EVENT SHALL PALADIN LIGHT CONSTRUCTION BE LIABLE FOR ANY LOSS OR CLAIM IN AN AMOUNT IN EXCESS OF THE PURCHASE PRICE, OR, AT THE OPTION OF PALADIN LIGHT CONSTRUCTION, THE REPAIR OR REPLACEMENT, OF THE PARTICULAR PRODUCT ON WHICH ANY CLAIM OF LOSS OR DAMAGE IS BASED. THIS LIMITATION OF LIABILITY APPLIES IRRESPECTIVE OF WHETHER THE CLAIM IS BASED ON BREACH OF CONTRACT, BREACH OF WARRANTY, NEGLIGENCE OR OTHER CAUSE AND WHETHER THE ALLEGED DEFECT IS DISCOVERABLE OR LATENT.

¹Attachment Technologies Inc., a subsidiary of Paladin Brands Holding, Inc. (PBHI) is referred to herein as Paladin Light Construction.

36" MULCHER ASSEMBLIES

28-41 GPM EXCAVATOR MULCHER ASSEMBLY #115620

42-60 GPM EXCAVATOR MULCHER ASSEMBLY #115621

MAINFRAME ASSEMBLY

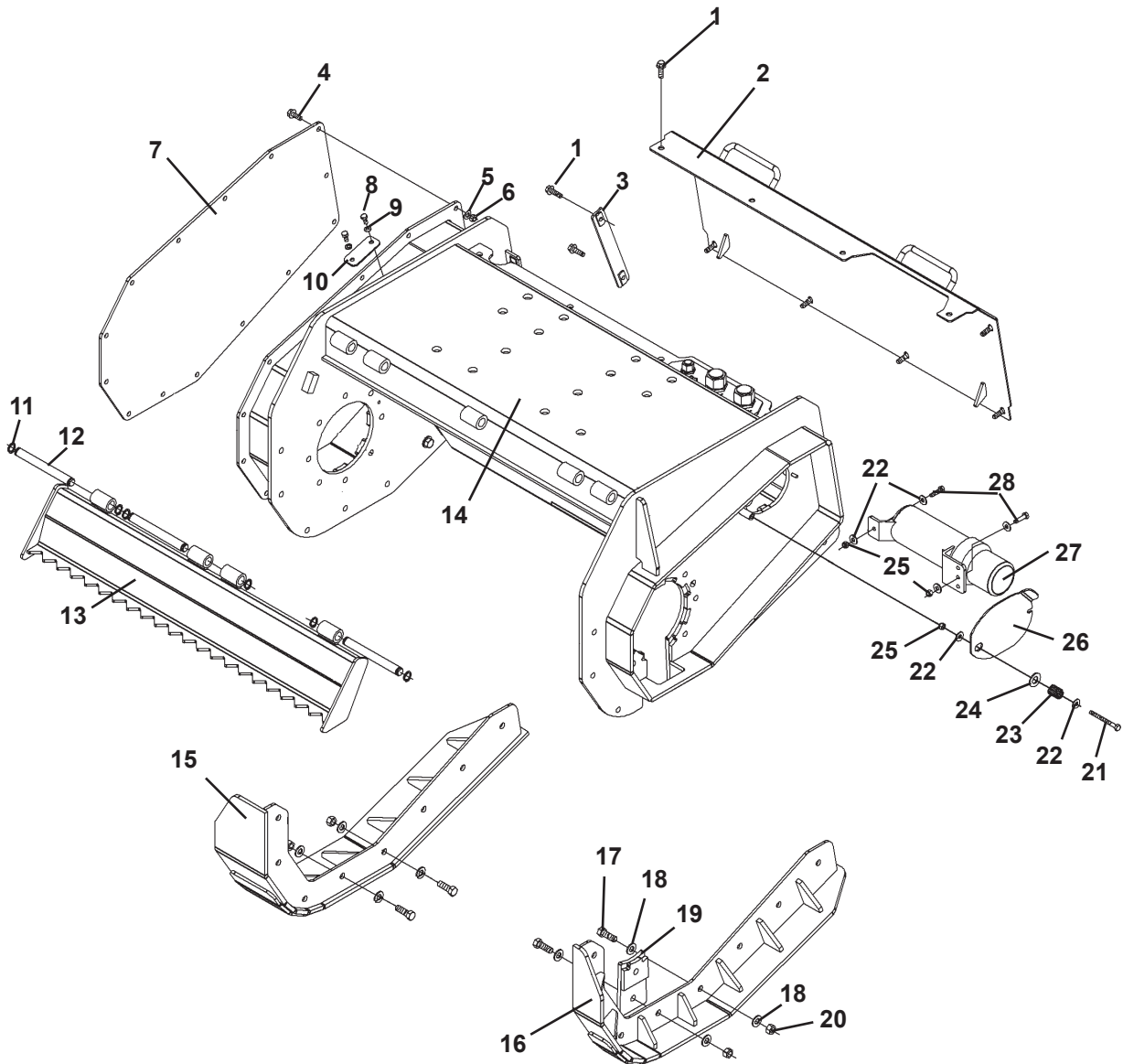

36" MULCHER ASSEMBLIES

28-41 GPM EXCAVATOR MULCHER ASSEMBLY #115620

42-60 GPM EXCAVATOR MULCHER ASSEMBLY #115621

MAINFRAME ASSEMBLY

<u>ITEM</u>	<u>REQ'D</u>	<u>PART NO.</u>	<u>DESCRIPTION</u>
1	12	10219	.38" UNC X 1.25" Flange Head Capscrew
2	1	112656	Rear Compartment Cover
3	1	115921	Housing Seal Plate
4	14	10218	.38" UNC X 1.00" Flange Head Capscrew
5	14	1525	.38" Flat Washer
6	14	1837	.38" UNC Deformed Lock Nut
7	1	112693	Drive Belt Cover
8	2	1021	.31" UNC X .75" Hex Capscrew
9	2	1502	.31" Lock Washer
10	1	110175	Belt Tension Access Cover
11	6	10222	Snap Ring
12	3	115566	Pivot Pin, 6.88" Long
13	1	112677	Deflector Door
14	1	115603	Mainframe
15	1	115649	Right Skid Shoe
	-	115654	Replacement Right Skid Shoe Wear Pad (Weld-On)
16	1	115650	Left Skid Shoe
	-	115658	Replacement Left Skid Shoe Wear Pad (Weld-On)
17	16	1090	.50" UNC X 1.50" Hex Capscrew
18	32	1527	.50" Flat Washer
19	1	115616	Left Side Filler Plate
20	16	1841	.50" UNC Deformed Lock Nut
21	1	1031	.31" UNC 3.25" Hex Capscrew
22	6	1513	.31" Flat Washer
23	1	110724	Access Door Spring
24	1	1528	.62" Flat Washer
25	3	1753	.31" UNC Nylock Nut
26	1	110284	Manual Access Door
27	1	25453	Manual Storage Tube
28	2	1023	.31" UNC X 1.25" Hex Capscrew

36" MULCHER ASSEMBLIES

28-41 GPM EXCAVATOR MULCHER ASSEMBLY #115620

42-60 GPM EXCAVATOR MULCHER ASSEMBLY #115621

ROTOR ASSEMBLY

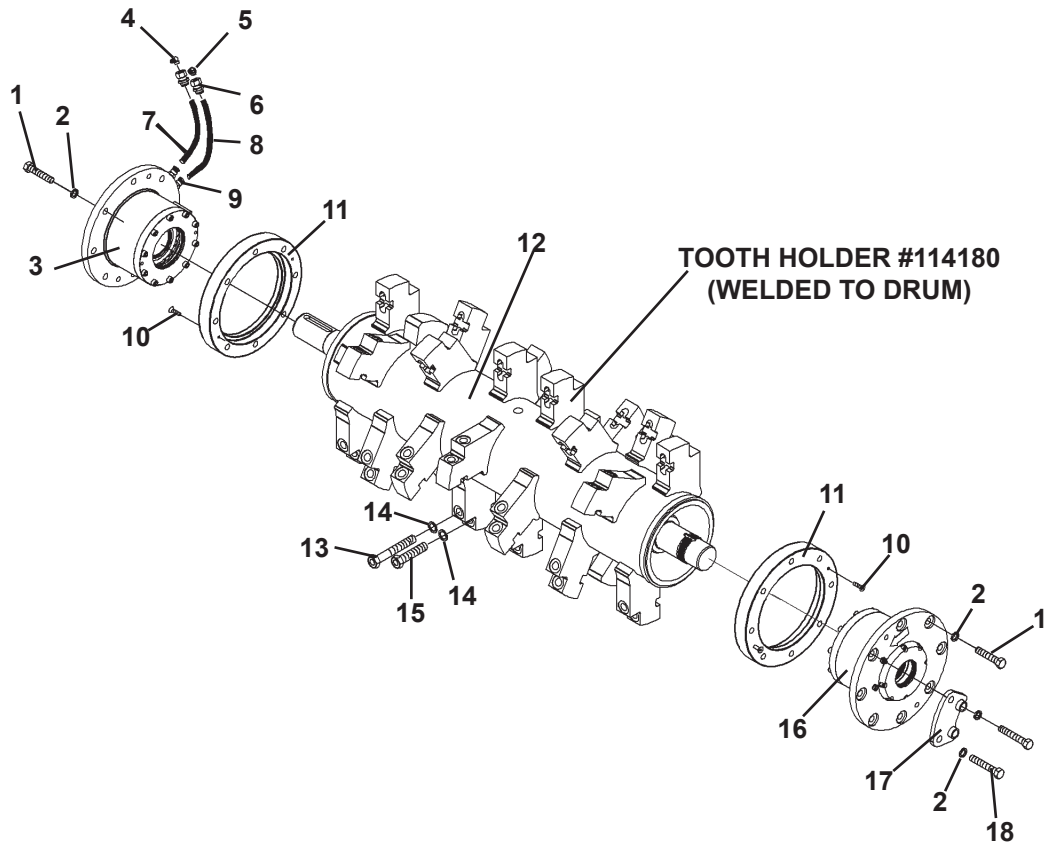

36" MULCHER ASSEMBLIES

28-41 GPM EXCAVATOR MULCHER ASSEMBLY #115620

42-60 GPM EXCAVATOR MULCHER ASSEMBLY #115621

ROTOR ASSEMBLY

<u>ITEM</u>	<u>REQ'D</u>	<u>PART NO.</u>	<u>DESCRIPTION</u>
1	14	1094	.50" UNC X 2.50" Hex Capscrew (install with Loctite 271 and torque to 80 ft. lbs.)
2	16	700-58096	.50" Nord Lock Washer
3	1	115441	Right Lower Bearing Assembly (See Maintenance Section for instructions on properly setting bearing assembly.)
4	1	9371	Grease Fitting
5	1	113935	Relief Vent
6	2	30466	Straight Bulkhead Connector 2FP-.31" Tube
7	1	115568	Nylon Hose .31" X 8"
8	1	115567	Nylon Hose .31" X 10"
9	2	30465	Straight Connector (Included in Lower Right Bearing Assembly)
10	4	1705	.25" UNC X 1.00" Flat Head Screw
11	2	801-210	Dirt Ring Flange
12	1	115646	Rotor (Balanced)
13	26	700-111	M16 X 110mm Hex Capscrew 1.5P
14	52	10165	16mm Lock Washer
15	26	700-114	M16 X 75mm Hex Capscrew 1.5P
16	1	115442	Left Lower Bearing Assembly (See Maintenance Section for instructions on properly setting bearing assembly.)
17	1	115618	Guard
18	2	1096	.50" UNC X 3.00" Hex Capscrew (Install with Loctite 271 and torque to 80 ft. lbs.)

36" MULCHER ASSEMBLIES

28-41 GPM EXCAVATOR MULCHER ASSEMBLY #115620

42-60 GPM EXCAVATOR MULCHER ASSEMBLY #115621

MOTOR AND DRIVE ASSEMBLY

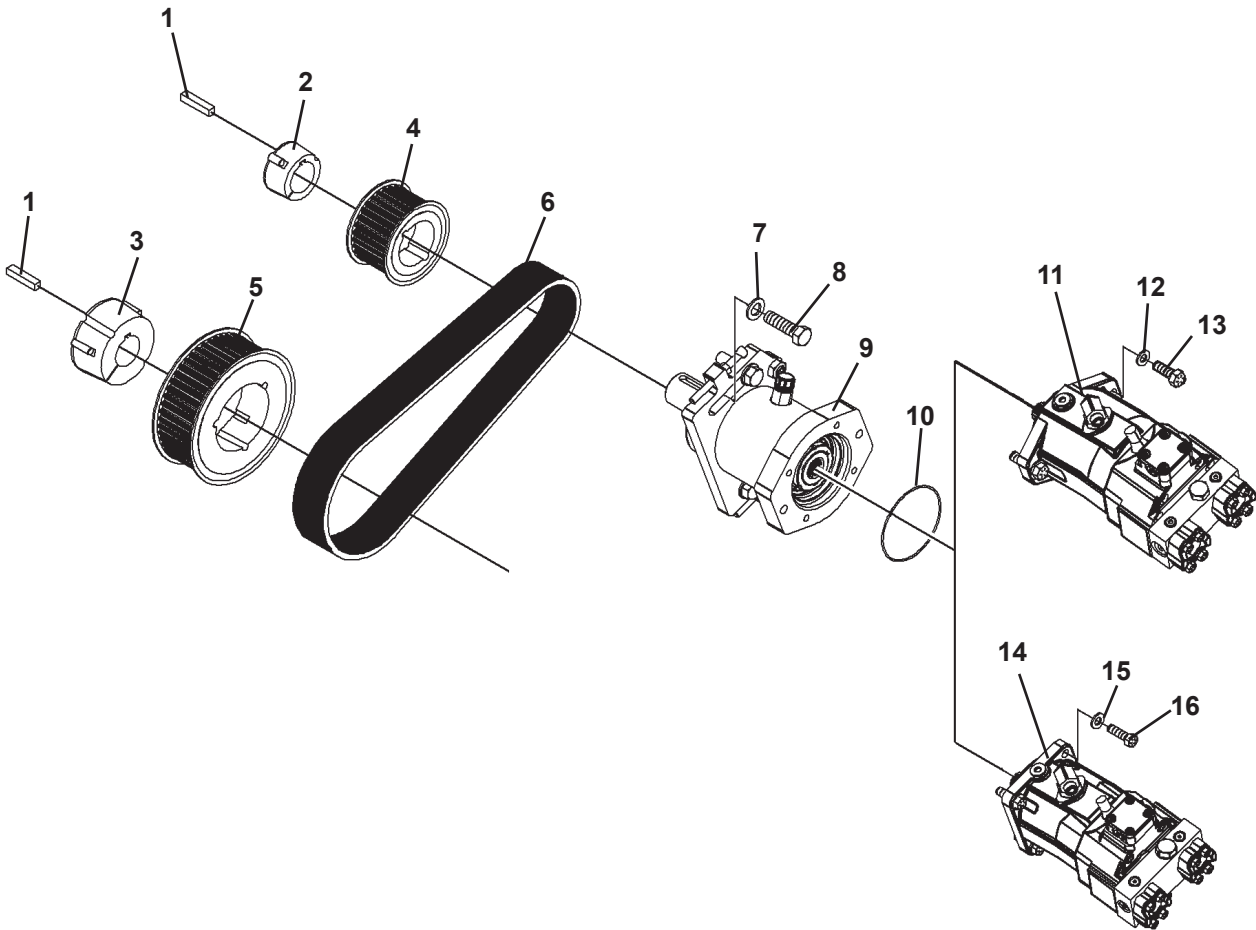

36" MULCHER ASSEMBLIES

28-41 GPM EXCAVATOR MULCHER ASSEMBLY #115620

42-60 GPM EXCAVATOR MULCHER ASSEMBLY #115621

MOTOR AND DRIVE ASSEMBLY

<u>ITEM</u>	<u>REQ'D</u>	<u>PART NO.</u>	<u>DESCRIPTION</u>
1	2	53780	Key .50" X 2.50"
2	1	113720	Taper Lock Bushing (2517X2.125) (Torque set screws to 36 ft. lbs.)
3	1	113594	Taper Lock Bushing (3525X2.125) (Torque set screws to 84 ft. lbs.)
4	1	113839	Sprocket 30T
5	1	113761	Sprocket 50T
6	1	113762	Drive Belt
7	4	1649	.75" Hard Flat Washer
8	4	1142	.75" UNC X 2.75" Hex Capscrew (Torque to 250 ft. lbs. after belt has been properly tensioned.)
9	1	115443	Overhung Load Adapter (Refer to Maintenance Section when ordering replacement Adapter.)
10	1	22609	Motor O'Ring
11	1	107251	Variable Displacement Motor - 80CC - 42-60 GPM Assembly (Check Maintenance Section for displacement settings.)
	-	45987	Replacement Motor Shaft Seal
12	2	1627	.62" Hard Flat Washer
13	2	10215	.62" UNF X 2.25" Hex Capscrew - Grade 8
14	1	112700	Variable Displacement Motor - 55CC - 28-41 GPM Assembly (Check Maintenance Section for displacement settings.)
	-	46067	Replacement Motor Shaft Seal
15	4	1646	.50" Hard Flat Washer
16	4	1964	.50" UNC X 1.75" Hex Capscrew - Grade 8

36" MULCHER ASSEMBLIES

28-41 GPM EXCAVATOR MULCHER ASSEMBLY #115620

42-60 GPM EXCAVATOR MULCHER ASSEMBLY #115621

HYDRAULIC SYSTEM ASSEMBLY

<u>ITEM</u>	<u>REQ'D</u>	<u>PART NO.</u>	<u>DESCRIPTION</u>
1	1	201-375	90° Elbow 8MFS-12MBo
2	1	38636	Hose, .50" X 18.50" 8FFS-8FFS 90°
3	1	30291	Straight Bulkhead Connector 8MFS
4	1	30424	Cap - 8FFS
5	1	112700	Variable Displacement Motor - 55CC - 28-41 GPM Assembly (Check Maintenance Section for displacement settings.)
	-	46067	Replacement Motor Shaft Seal
	1	107251	Variable Displacement Motor - 80CC - 42-60 GPM Assembly (Check Maintenance Section for displacement settings.)
	-	45987	Replacement Motor Shaft Seal
6	1	112701	Relief Block Valve (Used with #112700 Motor - 28-41 GPM Assembly)
	1	109542	Relief Block Valve (Used with #107251 Motor - 42-60 GPM Assembly)
	-	45990	Replacement Cartridge - Anti Cavitation
	-	46068	Replacement Cartridge - Pressure Relief
	-	30280	Replacement #4 Plug
	-	30326	Replacement #10 Plug
7	2	30437	Code 62 Clamp Assembly - .75" (28-41 GPM Assembly)
	2	3428	Code 62 Clamp Assembly - 1.00" (42-60 GPM Assembly)
8	8	10211	.38" UNC X 3.00" Hex Capscrew - Grade 8 (Torque to 30 ft. lbs.)
	8	10189	.44" UNC X 3.25" Hex Capscrew - Grade 8 (Torque to 45 ft. lbs.)
9	1	38638	Hose .75" X 22.62" 16FFS-12FLH30 (28-41 GPM Assembly)
	1	38640	Hose 1.00" X 22.75" 16FFS-16FLH30 (42-60 GPM Assembly)
10	1	38637	Hose .75" X 28.12" 16FFS-12FLH30 (28-41 GPM Assembly)
	1	38639	Hose 1.00" X 28.00" 16FFS-16FLH22 (42-60 GPM Assembly)
11	2	30447	Straight Bulkhead Connector 16MFS
12	2	30448	Cap - 16FFS

OVERHUNG LOAD ADAPTER ASSEMBLY

OVERHUNG LOAD ADAPTER ASSEMBLY #115443

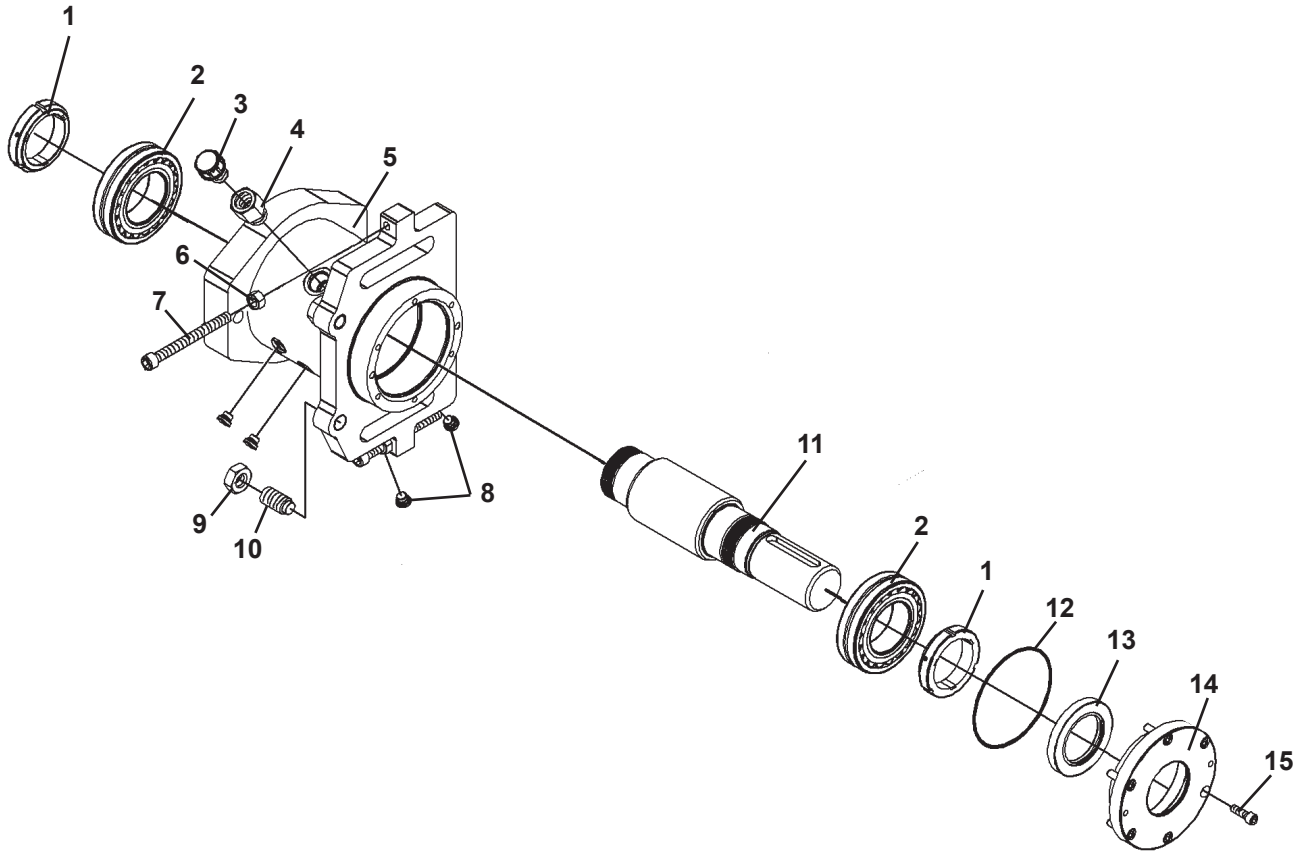

OVERHUNG LOAD ADAPTER ASSEMBLY

OVERHUNG LOAD ADAPTER ASSEMBLY #115443

<u>ITEM</u>	<u>REQ'D</u>	<u>PART NO.</u>	<u>DESCRIPTION</u>
1	2	NSS	Bearing Lock Nut
2	2	NSS	Roller Bearing
3	1	115440	Vent Breather - Pressurized
4	1	3324	Straight Connector 10MBo-8FP
5	1	NSS	Bearing Housing
6	2	1227	.44" UNC Hex Nut
7	2	700-115	.44" UNC X 4.50" Sockethead Capscrew
8	4	30280	Plug 4MBo
9	2	1495	.75" UNF Hex Jam Nut
10	2	10226	.75" UNF X 1.50" Set Screw
11	1	NSS	Drive Shaft
12	1	114499	O-Ring
13	1	114498	Drive Shaft Seal
14	1	114494	Retaining Seal Cap (See Maintenance Section for Installation Instructions.)
15	6	10066	.31" UNC X 1.00" Sockethead Capscrew (Install with Loctite 271 and torque to 25 ft. lbs.)
		NSS	Not Sold Separately

NOTE: DUE TO THE COMPLEXITY OF REPLACING THE DRIVE SHAFT, BEARINGS AND HOUSING THESE PARTS ARE NOT SOLD SEPARATELY. REFER TO MAINTENANCE SECTION FOR ORDERING REPLACEMENT OVERHUNG LOAD ADAPTERS.

LOWER BEARING ASSEMBLY

RIGHT LOWER BEARING ASSEMBLY #115441

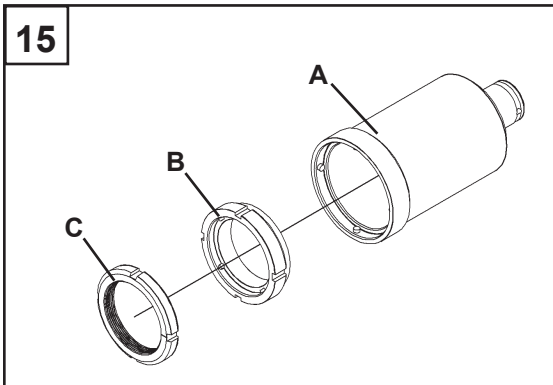
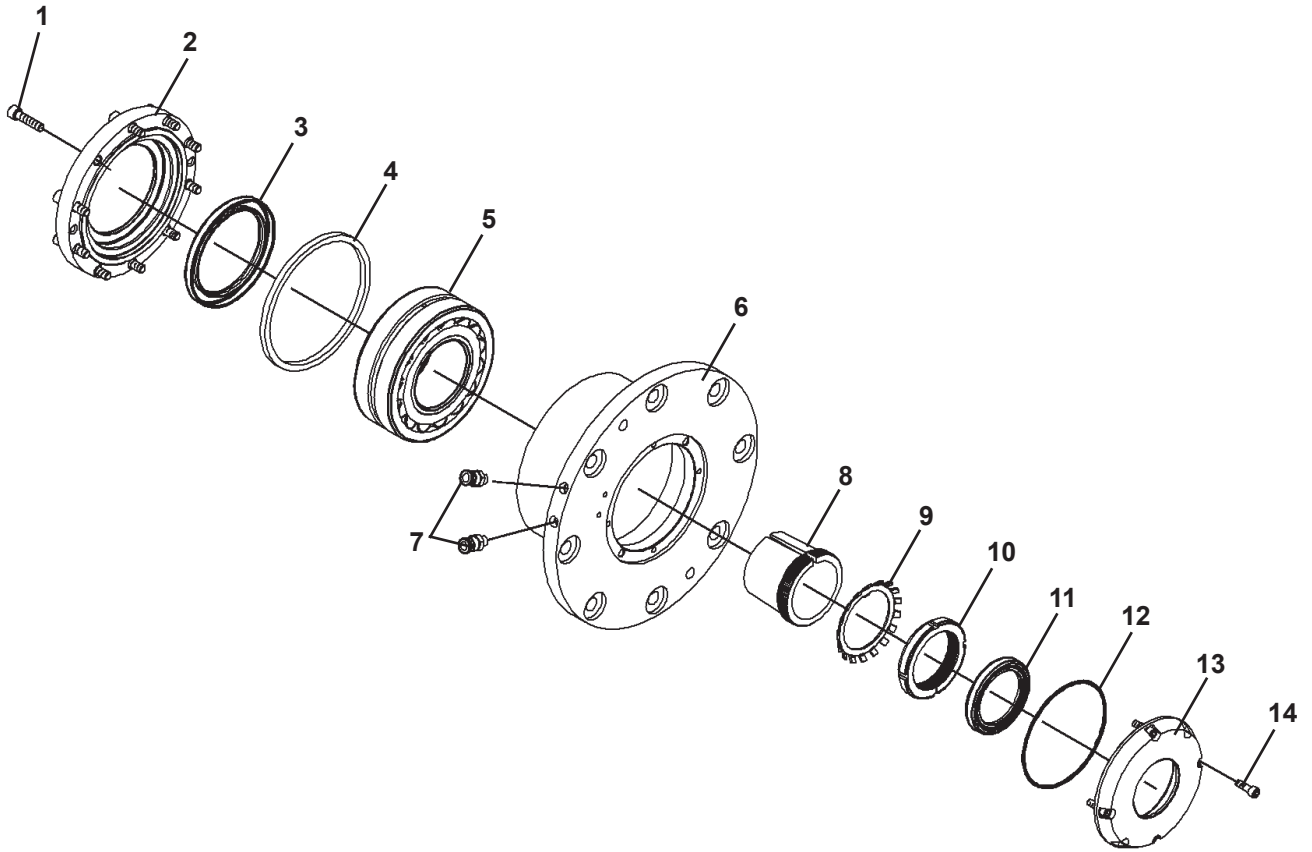

LOWER BEARING ASSEMBLY
RIGHT LOWER BEARING ASSEMBLY #115441

<u>ITEM</u>	<u>REQ'D</u>	<u>PART NO.</u>	<u>DESCRIPTION</u>
1	10	700-64145	.31" UNC X 1.25" Sockethead Capscrew (Install with Loctite 271 and torque to 25 ft. lbs.)
2	1	115549	Inner Seal Cap
3	1	45695	Rotor Shaft Seal
4	1	801-303	Bearing Spacer Ring
5	1	600-158	Roller Bearing (Refer to Maintenance Section for Service Instructions.)
6	1	115547	Right Bearing Housing
7	2	30465	Straight Connector 2MP-.31" Tube
8	1	115641	Withdrawal Sleeve
9	1	115643	Bearing Lock Washer
10	1	2006345	Bearing Lock Nut
11	1	600-159	Rotor Shaft Seal
12	1	45125	O'Ring
13	1	115550	Outer Seal Cap
14	4	1944	.25" UNC X .75" Sockethead Capscrew (Install with Loctite 271 and torque to 12 ft. lbs.)
15	-	116125	Optional Bearing Socket Assembly (Refer to Maintenance Section for Service Instructions.)
		116127	(A) Bearing Socket
		116128	(B) Bearing Socket Insert
		115645	(C) Bearing Lock Nut (For removal of Withdrawal Sleeve.)

LOWER BEARING ASSEMBLY

LEFT LOWER BEARING ASSEMBLY #115442

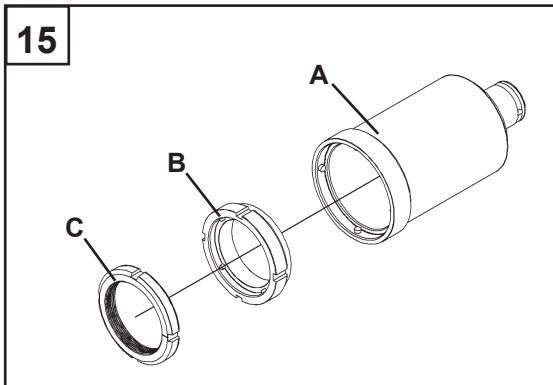
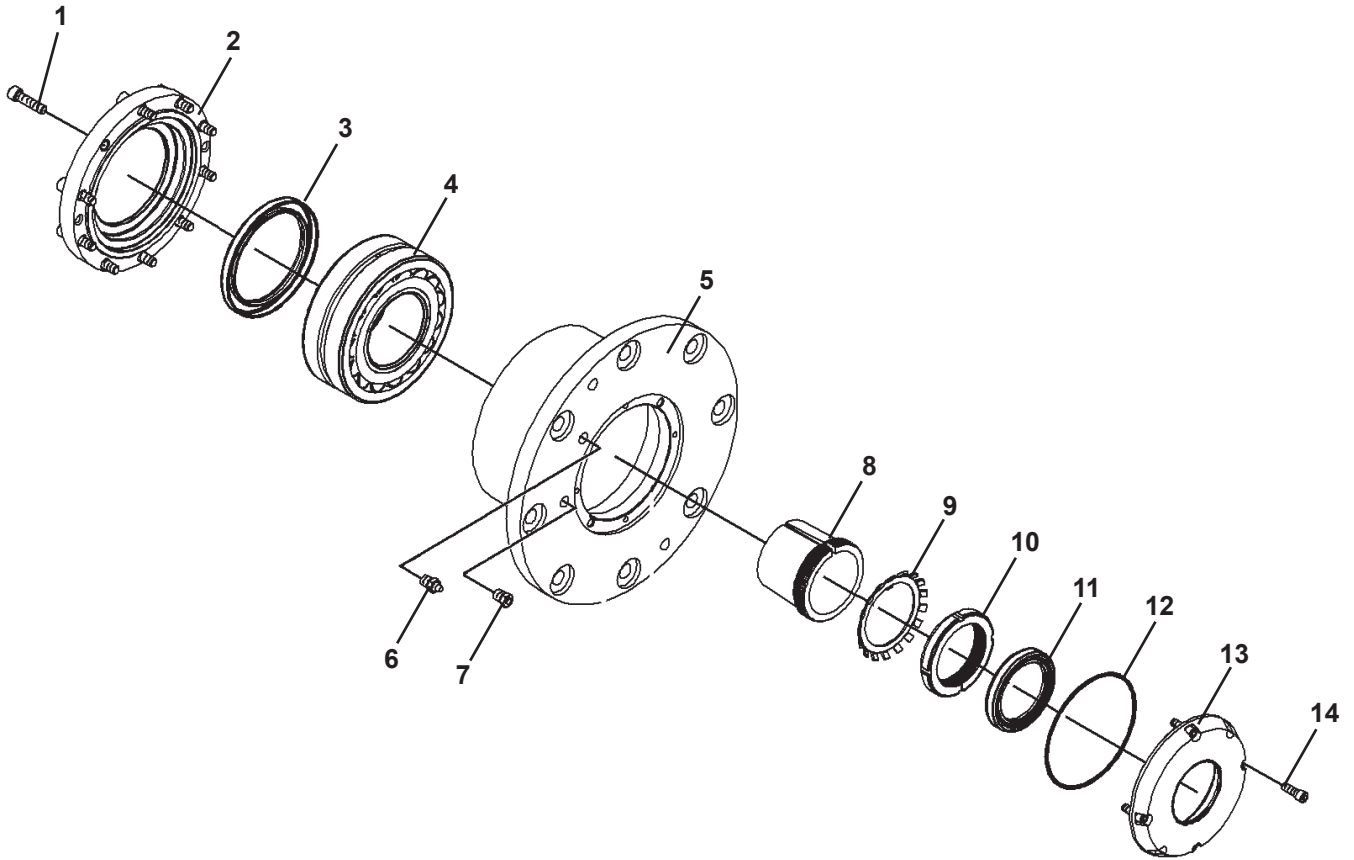

LOWER BEARING ASSEMBLY
LEFT LOWER BEARING ASSEMBLY #115442

<u>ITEM</u>	<u>REQ'D</u>	<u>PART NO.</u>	<u>DESCRIPTION</u>
1	10	700-64145	.31" UNC X 1.25" Sockethead Capscrew (Install with Loctite 271 and torque to 25 ft. lbs.)
2	1	115549	Inner Seal Cap
3	1	45695	Rotor Shaft Seal
4	1	115439	Roller Bearing (Refer to Maintenance Section for Service Instructions.)
5	1	115548	Left Bearing Housing
6	1	9371	Grease Fitting
7	1	113935	Relief Vent
8	1	115641	Withdrawal Sleeve
9	1	115643	Bearing Lock Washer
10	1	2006345	Bearing Lock Nut
11	1	600-159	Rotor Shaft Seal
12	1	45125	O'Ring
13	1	115550	Outer Seal Cap
14	4	1944	.25" UNC X .75" Sockethead Capscrew (Install with Loctite 271 and torque to 12 ft. lbs.)
15	-	116125	Optional Bearing Socket Assembly (Refer to Maintenance Section for Service Instructions.)
		116127	(A) Bearing Socket
		116128	(B) Bearing Socket Insert
		115645	(C) Bearing Lock Nut (For removal of Withdrawal Sleeve.)

TOOTH KIT OPTIONS

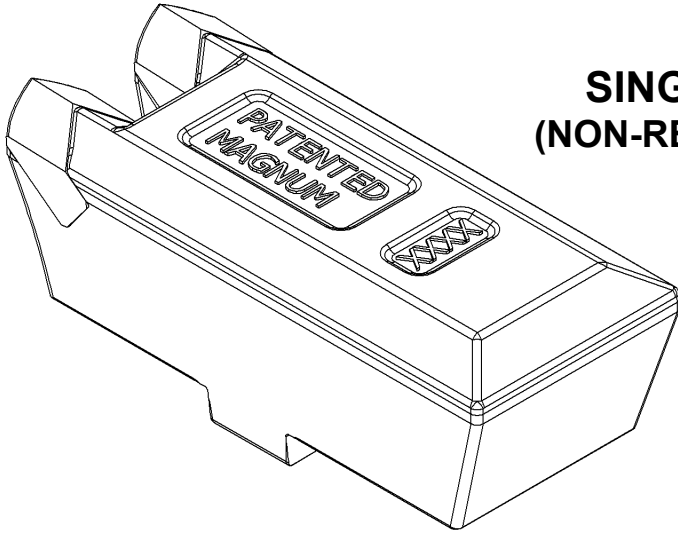

**SINGLE TOOTH (#600-112-1)
(NON-REVERSIBLE HAMMER TOOTH)**

**DOUBLE TOOTH (#600-168)
(REVERSIBLE HAMMER TOOTH)**

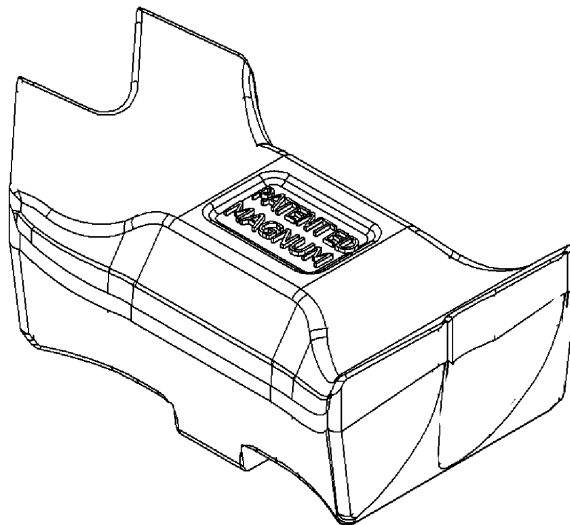
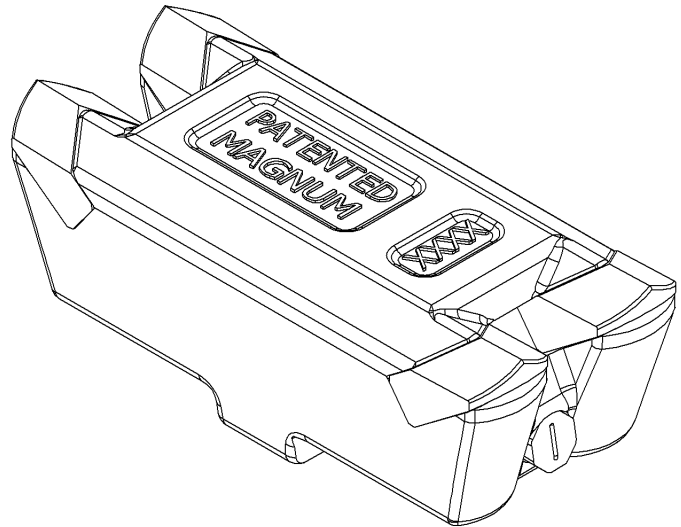

**CLAW TOOTH (#111588)
(REVERSIBLE CLAW TOOTH)**

TOOTH KIT OPTIONS

SINGLE TOOTH (#600-112-1) TOOTH SETS (All Kits Include Lock Washers)

<u>KIT PART NO.</u>	<u>TOOTH QTY</u>	<u>DESCRIPTION</u>
109471	10	Single Tip, Non-reversible, Tooth
116087	26	Single Tip, Non-reversible, Tooth
113936	27	Single Tip, Non-reversible, Tooth
116090	44	Single Tip, Non-reversible, Tooth
109472	50	Single Tip, Non-reversible, Tooth
111793	54	Single Tip, Non-reversible, Tooth
113738	64	Single Tip, Non-reversible, Tooth
109473	100	Single Tip, Non-reversible, Tooth

DOUBLE TOOTH (#600-168) TOOTH SETS (All Kits Include Lock Washers)

<u>KIT PART NO.</u>	<u>TOOTH QTY</u>	<u>DESCRIPTION</u>
109468	10	Double Tip, Reversible, Tooth
116088	26	Double Tip, Reversible, Tooth
113937	27	Double Tip, Reversible, Tooth
116091	44	Double Tip, Reversible, Tooth
109469	50	Double Tip, Reversible, Tooth
111794	54	Double Tip, Reversible, Tooth
113932	64	Double Tip, Reversible, Tooth
109470	100	Double Tip, Reversible, Tooth

CLAW TOOTH (#111588) TOOTH SETS (All Kits Include Lock Washers)

<u>KIT PART NO.</u>	<u>TOOTH QTY</u>	<u>DESCRIPTION</u>
112579	25	Claw Tooth, Reversible, Tooth
116089	26	Claw Tooth, Reversible, Tooth
113938	27	Claw Tooth, Reversible, Tooth
116092	44	Claw Tooth, Reversible, Tooth
112580	50	Claw Tooth, Reversible, Tooth
112578	54	Claw Tooth, Reversible, Tooth
113933	64	Claw Tooth, Reversible, Tooth
112581	100	Claw Tooth, Reversible, Tooth

NOTE: ALL TOOTH SETS INCLUDE LOCK WASHERS. INSTALLATION CAPSCREWS ARE INCLUDED IN MULCHER ASSEMBLY.

(M16 X 110MM CAPSCREW - #700-111, M16 X 75MM CAPSCREW - #700-114, AND 16MM LOCK WASHER - #10165)

11948 7-15-14-3

OPTIONAL ACCESSORIES

Socket Assemblies

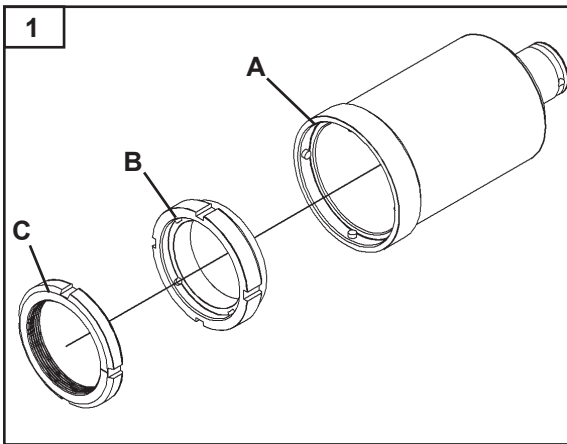

Case Drain Relief Valve Kits

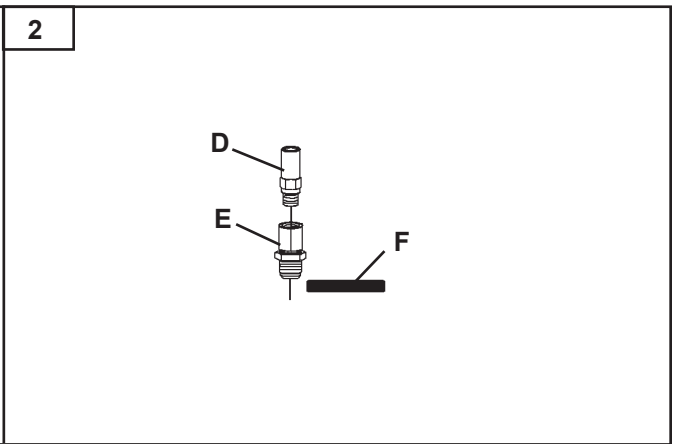

OPTIONAL ACCESSORIES

<u>ITEM</u>	<u>PART NO.</u>	<u>DESCRIPTION</u>
1	<u>Socket Assemblies</u>	
	116125	Bearing Socket Assembly (Lower Bearings) (Refer to Maintenance Section for Service Instructions.)
	116127	(A) Bearing Socket
	116128	(B) Bearing Socket Insert
	115645	(C) Bearing Lock Nut
2	<u>Case Drain Relief Valve Kits</u>	
	116930	Case Drain Relief Kit
	112703	(D) Case Drain Relief Valve
	3284	(E) Straight Connector 8FP-12MBo
	41078	(F) Decal, Back Pressure