

Operation & Parts MANUAL

for the

165-MINI MAG

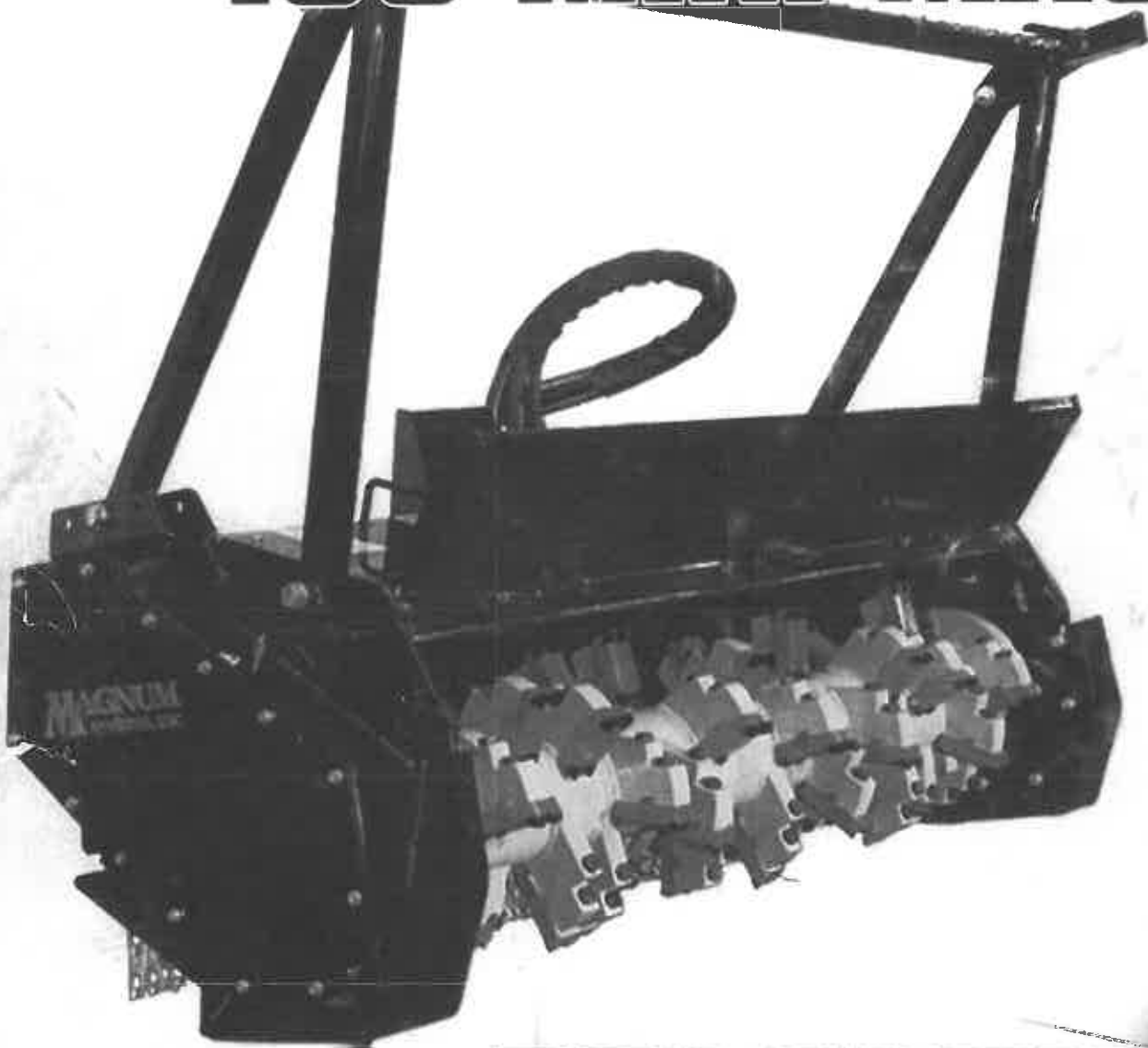

MAGNUM
systems, inc.

866/562-4686 Toll Free

SAFETY PRECAUTIONS

Your Magnum Mulcher has been designed and manufactured with high quality materials and care in workmanship. This manual is intended as a permanent reference to aid professional operators in their work, and should be available for use at any time. If the machine is not equipped with this manual, ask your supervisor to obtain one for you.

Understand the correct servicing procedures before servicing the machine. It is important to know the correct operating and servicing procedures of the Magnum 165 Mini-Mag Mulcher and all safety precautions to prevent the possibility of property damage and/or personnel injury or death.

As a professionally, trained operator, you are responsible for safety, both your own and that of all other personnel.

Your knowledge and use of all safety practices and correct servicing procedures in this manual, and your good judgment, can be a major factor in preventing some of the thousands of injuries and deaths caused by industrial accidents each year.

A professional operator should also be familiar with the information contained in other applicable sources such as American National Standards, SAE, OSHA, etc.

DON'T FORGET – SAFETY FIRST!!!!

INFORMATION

All requests for information, service or parts should include mulcher serial number. For more information contact

REFERENCE

The Mini – Mag Mulcher serial number plate is on the backside of the belt guard on the right side of mulcher head.

Magnum Systems, Inc.
6014 Bonacker Drive
Tampa, FL 33610
Phone Number: 813-623-2699
Fax Number: 813-623-2799

NOTE: Information in this manual is current at the time of printing. Magnum Systems Inc. reserves the right to make changes and improvements to its products and manuals at any time without notice or obligation. **This manual is intended to be used for the operation and maintenance of the Magnum 165 Mini-Mag Mulcher only.** Refer to your tractors manuals for information regarding maintenance and operation of the tractor.

TABLE OF CONTENTS

Section	Page No.
Safety precautions	1 - 9
Proper Installation	10 - 11
Operation	12 - 13
Maintenance	14 - 18
Warranty	19 - 20
Cutting Hammer Options and Installation	21 - 22
Skid Plate Adjustment	23
Hydraulic Pressure Sight Gauge	24
Push Bar Adjustment	25
Hydraulic Deflector Door	26
Belt Drive and Pulleys	27 - 30
Hydraulic Motor – Hoses and Fittings	31
Upper Bearing Housing and Hydraulic Motor	32 - 35
Lower Bearing and Rotor	36 - 39
Parts Schematic and Parts Lists	40 - 43

SAFETY PRECAUTIONS
HYDRAULIC PRESSURE WARNING SHEET
165 Mini-Mag

!WARNING

MAXIMUM PRESSURES FOR THIS MACHINE ARE AS FOLLOWS IN THE CHART BELOW. SETTINGS HIGHER THAN THESE MAY RESULT IN DEATH, SEVERE INJURY OR PROPERTY DAMAGE!!!

HYDRAULIC PRESSURE SETTINGS

MAIN SYSTEM	5000 + 50 PSI
RETURN LOOP	160 PSI

In many instances, we have learned that the hydraulic relief valves of this attachment have been reset, increasing the maximum pressures, and with it, the load the unit will operate under before the relief valve opens. In some instances, the consequences of increasing this setting have been serious. The function of the relief valve is to provide a fuse action to protect the equipment and the operator from overloading. When overloaded, different portions of the attachment can become stressed to a level where parts fracture, possibly resulting in death, severe injury or property damage. **This is an extremely dangerous practice.**

Accordingly, you are advised that the settings of these valves are limited to the maximums listed above. **Pressure settings in excess of these levels render each and all Magnum warranties null and void and constitute an obvious misuse and abuse of our product.**

MAGNUM SYSTEMS INC.

SAFETY PRECAUTIONS

The following is a list of some important safety precautions and warnings you should read through and understand before operating your machine:

- Failure to follow the safety precautions in this manual can result in personnel injury or property damage. Carefully read the safety cautions below and within this manual. Heed all decals mounted to the machine.

DANGER! – Indicates immediate hazards, which **WILL** result in severe injury or death.

WARNING! - Indicates hazards or unsafe practices, which **COULD** result in severe personal injury or death.

CAUTION! - Indicates hazards or unsafe practices, which **COULD** result in damage to the machine or minor personnel injury.

DANGER!

Never approach power lines with any part of the machine or load. Current in high voltage lines may arc some distance to jump from the wire to a nearby "ground". **KEEP WELL CLEAR!**

WARNING!

Clear all persons and obstacles from area of operation and machine movement. Do not move attachment or loads over personnel.

WARNING!

Keep all personnel back **300 feet** from machine when operating. Flying debris can cause death or severe injury.

WARNING!

Know the prohibited uses or work areas for the machine and the hand signals used on the job.

WARNING!

Always lower the attachment to the ground and shut down attachment before leaving cab.

WARNING!

Operator should be certain that the rear of the machine is clear before operating. The visibility is limited.

WARNING!

Position the attachment as low as possible during mulching operations for better stability and visibility. The operator must handle the machine so that maximum stability is maintained, and must be familiar with the stability and weight of the machine.

SAFETY PRECAUTIONS

DANGER!

Do not allow personnel under raised lift arms or mulcher attachment for any reason, unless they are supported so they cannot fall in any way.

WARNING!

Remove or secure all personal or maintenance items such as lunch buckets, chains, tools, shovels, etc. before operating machine.

WARNING!

Make sure that all walking and climbing surfaces of machine are free of dirt, oil, debris, water, grease, and snow. Do not leave loose tools or rags on machine.

WARNING!

Always wear seat belts when operating or driving machine.

WARNING!

Allow only the operator on machine. Keep riders off. Riders on attachment are subject to injury and being thrown from machine. Riders also obstruct the operators view and create a safety hazard. Never use the attachment or any other part of machine to transport people or as a work platform. Serious injury and death may occur.

WARNING!

Know how to put your machine in a zero energy state for purposes of maintenance, inspection or repair.

WARNING!

High-pressure hydraulic fluid can penetrate skin causing death, gangrene or other severe injury. Seek immediate medical attention to remove fluid.

- Keep hands and body away from areas ejecting fluid. Use a piece of cardboard to check for leaks. Wear proper hand and eye protection.
- Relieve pressure before loosening any hose or fitting connections.
- Tighten all connections before re-pressurizing system.

WARNING!

Replace any decals that are worn, faded, illegible, or otherwise damaged.

WARNING!

Loose or overtorqued bolts can cause death, severe injury, or property damage. Maintain proper bolt torque. Visually check bolts daily. Check torque every 50 hours.

WARNING!

Before operation, transparent material such as safety glass must be replaced when it is cracked or broken, or when vision is obscured due to scratches.

WARNING!

Always maintain a three-point contact with handles and steps when mounting. Never jump on or off machine.

SAFETY PRECAUTIONS

WARNING!

A complete cleaning and inspection should be done on a weekly basis to prevent fire hazards. Check the complete machine for any cracks or needed repairs.

WARNING!

Rotating mulcher head will cause death or severe injury. Do not start up mulcher attachment until all personnel are **300 feet** from mulcher head. Shut down the mulcher head when not in use.

WARNING!

Wear required personal protective gear at all times to help prevent injury.

WARNING!

The operator should always be aware when mulching dead standing trees. There is a danger of the treetop falling back onto the operator cab and causing injury or property damage.

WARNING!

Do not operate or work on machine until you do the following:

- Read and understand machine manuals, safety decals, employer work rules, and applicable government regulations.
- Have been trained and are qualified in safe machine operation and maintenance.
- Consult your supervisor to explain any unclear instructions and warnings.
- Replacement manuals can be purchased from your Magnum dealer if they are lost or illegible.

DANGER!

The Magnum 165 Mini-Mag Mulcher should never be operated without a safety windshield in place on the carrier machine. Failure to comply with could result in death and/or serious injury.

SAFETY PRECAUTIONS

- Don't assume that because you know the control functions of other similar machinery, you can operate the Magnum 165 Mini-Mag Mulcher. All machines differ in some ways, and these differences must be noted and acknowledged. In addition to the design and configuration of this implement, including Safety Signs and Safety Equipment, hazard control and accident prevention are dependent upon the awareness, concern, prudence, and proper training of personnel involved in the operation, transport, maintenance, and storage of the machine. Refer also to Safety Messages and operation instruction in each of the appropriate sections of the Magnum Mini-Mag 165 Mulcher manuals. Pay close attention to the Safety Signs affixed to the attachment.
- Read this manual thoroughly and understand all operating and safety procedures before operating the machine.
- There are obvious and hidden potential hazards in the operation of this machine. **REMEMBER!** This machine is often operated in rough terrain and conditions where bystanders may be present. The hammers of this machine can throw things if the shields and safety chains are not installed and maintained properly. Serious injury and death can occur if care is not taken to insure the safety of the operator, bystanders, or passersby in the area.
- The Magnum 165 Mini-Mag Mulcher has a deflector door on the front of the head to help prevent debris from being thrown. This door can be opened to access the rotor for maintenance and to cut down larger diameter material. When operating this door, you move the safety door up, thus allowing debris to be thrown forward. This must never be done while machine is facing other personnel. Severe injury and death may occur.
- The Magnum 165 Mini-Mag Mulcher is equipped with safety chains on the rear of the mulching head. Care must be taken by the operator not to tilt the head too far forward while operating, as this will lift the chains off the ground and can allow debris to be thrown and create a serious safety hazard. This can cause severe injury and death to bystanders.
- Know how to put your machine in a zero energy state for purposes of inspection, maintenance, and/or repair.
- **The Mini-Mag mulcher attachment should never be operated more than 18" above the ground. Failure to heed this warning can result in serious injury and or death.**
- Clear operating area of all obstacles and personnel before operating machine, all personnel should be **300 feet** from machine before starting mulcher head.
- Never approach power lines with any part of machine! Current in a high voltage line may arc across to machine as a "ground". **KEEP WELL CLEAR!**
- Never use an attachment or any other part of the machine as a work platform or personnel carrier. Serious injury or death may result.
- **Allow only the operator on the machine.** Keep riders off. Riders on attachment are subject to injury such as being struck by foreign objects and being thrown off the machine. Riders also obstruct the operators view, resulting in the machine being operated in an unsafe manner.

SAFETY PRECAUTIONS

- When machine is not in operation and before leaving cab, shut down mulcher attachment and lower to the ground. Failure to do so may allow attachment to move or fall, resulting in severe injury or death.
- Do not allow personnel under raised lift arms or mulcher attachment for any reason unless lift arms are supported so they cannot fall in any way.
- Do not tamper with any hydraulic line while it is pressurized. Escaping fluid under pressure can penetrate the skin, causing serious injury. Relieve pressure before unhooking hydraulic fittings or lines. Tighten all connections before applying pressure. Keep hands and body away from pinholes and nozzles that eject fluid under high pressure. Use a piece of cardboard to search for leaks. If any fluid is injected into the skin, it must be surgically removed immediately or gangrene may result.
- Replace any safety decals that are faded, torn, missing, illegible, or otherwise damaged. See your machines parts manual for decal kits applicable to your machine and for locations of all decals.
- **IMPORTANT!** Never engage or disengage mulcher head while the engine rpm's are above 750.
- **IMPORTANT!** It is very critical to hydraulic component life to allow the hydraulic oil to warm up before operating machine at full operating speeds. Failure to do this will lessen the life of components and may void warranty.
- To properly engage mulcher head: First, be certain that all personnel are clear from operating area. Second, increase engine rpm's slightly to keep from stalling the engine. Third, engage head and increase rpm's to maximum level. **Failure to follow this procedure may result in extensive hydraulic system damage and possibly void warranty.**
- While operating the mulcher, the operator can adjust ground speed based on the hydraulic gauge that is mounted on the hood of the attachment. The maximum operating pressure of the attachment is 5000 PSI. The actual operating pressure that the attachment will operate at is whatever the system pressure of the carrier is. By watching the gauge and keeping pressure under max. operating pressure, you will extend the life of all hydraulic components. If you happen to go over the max operating pressure you will have to slow down, and or back out of the work to allow the head to recover speed. As the head recovers speed the gauge will start to go down to a lower pressure reading.
- To properly shut down mulcher attachment: Gradually decrease engine rpms down to an idle. The speed of the mulcher head will decrease gradually as engine decreases. Once the mulcher head has reached idle speed it will be safe to turn switch to the off position. The operator must be certain to follow proper parking procedures before leaving operators seat. **Failure to follow this procedure may result in extensive hydraulic system damage and possibly void warranty.**
- **Do not** attempt to jump from machine in event of a tip over. Remain seated with seat belt fastened until machine comes to a complete stop.

SAFETY PRECAUTIONS

- Visibility may be impaired by structural design. (Always look in the direction of travel; do not rely on mirrors.)
- Always at the end of the day, the operator should do a walk around inspection to insure that all guards, safety chains, nuts, bolts, and hammers are in good operating condition. The life of any piece of equipment depends on the preventive maintenance that's followed.
- To help preserve fuel, if the material you are mulching is light enough, the operator can lower the rpm's of the engine while mulching.
- **It is very important that the hammers on the mulching head are inspected and maintained at all times.** Hammers that are broken and/or missing will create unnecessary wear and vibration and can void all warranties that are associated with the Magnum 165 Mini-Mag mulcher.
- The operator should always listen for odd noises while running the machine — anything that is out of the ordinary should be checked immediately to determine if repairs are required.
- **Magnum Systems Inc.** uses dynamically balanced and matched system components for hammers, hammer holders, bearings, drive-train components, and hydraulic motors. These parts are made and tested to Magnum Systems Inc. specifications. Non-genuine or after-market parts do not meet these specifications. The use of non-Magnum recommended parts might reduce performance, void warranties, and possibly cause a safety hazard.

**Use genuine Magnum parts
for quality, economy and safety.**

SAFETY DECALS

The Magnum 165 Mini-Mag Mulcher is equipped with safety decals that should be read and understood by the operator and anyone else that is around the machine while it is in operation. All decals on the machine should be replaced if they become illegible, faded, torn, etc. Never allow anyone to ride on the machine at any time. Failure to adhere to this safety precaution could result in death and/or serious injury. When starting the mulcher up for operation, the operator should make sure that all bystanders are at least **300 feet** from the operation.



<i>magnum systems</i> decals	40942
Complete decal kit	Part # MS165-00-05
DANGER! No Riders	Part # MS500-00-07
WARNING! Flying Debris	Part # MS500-00-06
DANGER! <i>stand clear</i> Stay Clear	Part # MS500-00-38 4103
Grease Daily	Part # MS165-00-04
Anti Skid 16 x 6	Part # MS165-00-03
Anti Skid 24 x 6	Part # MS165-00-02
Name	Part # MS165-00-01

SEE YOUR MAGNUM SYSTEMS INC. DEALER FOR ALL YOUR PARTS

PROPER INSTALLATION

CONNECTING THE MAGNUM 165 MINI-MAG TO A SKID STEER MACHINE

Any and all personnel that will be involved in the attachment of the Mulcher head to the skid steer carrier must be trained and understand the mechanics of how the quick attach couplers and quick connectors on the hoses work.

Magnum Systems Inc. will not accept any liability with regard to accidents caused by the failure to instruct and train personnel in the proper operation of the Magnum 165 Mini-Mag Mulcher.

Before beginning work, be sure that all levels and wear items are checked and in the proper operating condition.

Connecting the attachment to the skid steer can be a very dangerous operation. The operator should make sure that all personnel are clear, before attempting to attach the mulcher head to the carrier.

It is critical to make sure that the skid steer is of suitable size and power to be able to operate the Magnum 165 Mini-Mag Mulcher.

When connecting the Magnum 165 Mini-Mag Mulcher to a skid steer it is very important to follow the skid steer manufacturers recommended procedure for attaching implements to the machine.

When attaching the hoses to the skid steer, the case drain line must be connected first, then the other hoses. When disconnecting the hoses, it is recommended to disconnect the case drain line last. This will prevent any over pressurization of the motor case on the mulcher head.

The quick couplers on the hoses have a safety lock ring that should be twisted, so as to activate the lock to prevent the hoses from popping off.

Each hose has an identification tag wrapped around it to inform the operator as to which hose gets connected to which fitting on the skid steer. Be certain to connect hoses to the proper location to prevent hydraulic system damage.



HOSE TO TRACTOR HOOK-UP

IMPORTANT!

Case drain hose

The case drain hose coming from the mulcher head to the tractor or carrier must never become pinched, removed from the machine while in operation, or have any type of restriction at any time. Any quick connect fitting used on the case drain line should be bi-directional, with no check valve or flow restrictions. Any type of restriction in this line will cause severe hydraulic system damage and could void warranty. When connecting mulcher head to a carrier, you should always connect the case drain line first, and when disconnecting machine you should always disconnect the case drain line last.

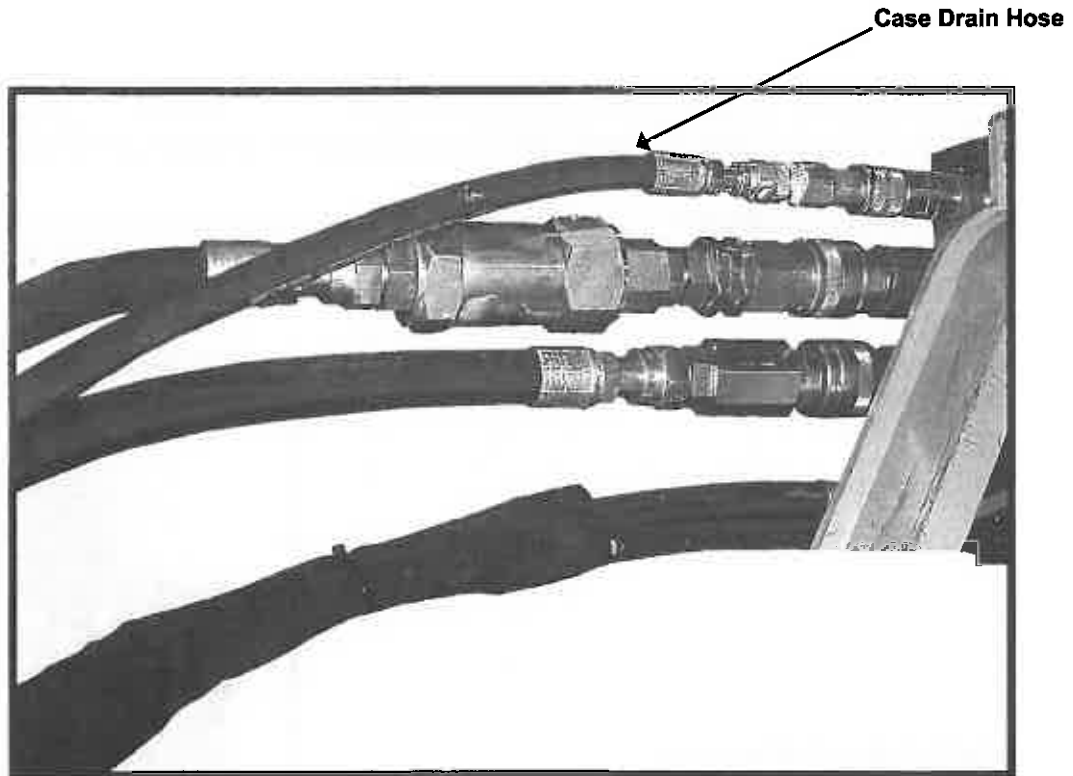

OPERATIONS

The following section gives suggested guidelines for operations of your attachment.

Read and understand the warnings and safety precautions in this manual before operating the Magnum 165 Mini-Mag Mulcher attachment.

After properly attaching the Magnum 165 Mini-Mag Mulcher attachment to the skid steer, (see Proper Installation section, page 11) you are ready to commence work with the 165 attachment. The following procedure should be followed:

- Before starting any mulching operation, be certain that there is a **protective shatterproof type, safety windshield** in place on the skid steer. **This will prevent debris from being hurled into the cab and operator. To operate without this safety shield in place could cause severe injury and/or death.**
- To start the mulching attachment, rev the skid steer engine up slightly above a normal idle (not more than approximately $\frac{1}{4}$ of the full throttle). This will prevent the engine from stalling. Then engage the high flow switch, insuring that the rotor is rotating in the proper direction. In the event that the rotor is not rotating in the proper direction, follow the instructions for disengaging rotor.
- **TO DISENGAGE THE ROTOR: YOU MUST FIRST IDLE THE ENGINE ALL THE WAY DOWN AS FAR AS IT WILL GO AND GIVE THE ROTOR TIME TO COAST DOWN TO AN IDLE SPEED BEFORE DISENGAGING THE HIGH FLOW SWITCH. AFTER YOU TURN THE SWITCH TO THE OFF POSITION, AND THE ROTOR HAS COME TO A COMPLETE STOP, WILL IT THEN BE SAFE TO RESTART THE ROTOR IN THE PROPER DIRECTION. YOU MUST NEVER CHANGE THE DIRECTION OF THE HIGH FLOW SWITCH WHILE THE ROTOR IS MOTION. FAILURE TO FOLLOW THIS SHUT DOWN AND RESTART PROCEDURE WILL CAUSE SEVERE DAMAGE TO THE HYDRAULIC SYSTEM OF THE ATTACHMENT AND WILL VOID ALL WARRANTIES ASSOCIATED WITH THE 165 MINI-MAG MULCHING ATTACHMENT.**
- **Care should be taken when shutting the high flow switch to the off position not to inadvertently switch the direction of the flow to the attachment. This will cause severe hydraulic component damage and void all warranties associated with the 165 Mini-Mag attachment.**
- The 165 Mini-Mag is equipped with a hydraulically operated deflector door. This door is used to deflect debris down to the ground, and will help minimize the throwing of debris. Before engaging the attachment into a mulching operation make sure that the deflector door is in the open position. This will prevent the door from being pushed into the rotor and being damaged. The door is not designed to push brush and/or trees. It is the operator's responsibility to ensure that the door is in the proper operating position at all times. **The deflector door is designed to minimize debris from becoming dangerous projectiles, which can cause serious injury and/or death. The operator must always insure the safety of all personnel and bystanders.**
- **Never lift the mulcher attachment higher than 18" above the ground level while mulching trees and/or brush. This dangerous operating practice will cause projectiles to be hurled into the cab and operator causing serious injury and/or death.**

OPERATIONS

- The mulcher attachment is designed to mulch while traveling forward or backing up — this greatly improves production. It is very important not to operate at a ground speed that is **too fast**, doing this will cause the rotor to engage too much material and stall. In the event of the rotor stalling, the operator will have to stop and lift the attachment from the material and allow the rotor to regain speed, this will take approximately 4 seconds. The operator can watch the pressure gauge to help control ground speed by slowing down when the pressure gauge approaches maximum operating pressure. The gauge will go up toward maximum pressure as more material is entered into the rotor, as you slow down and reduce the amount of material the gauge will go down.
- The mulcher head is capable of mulching and mixing debris approximately 1-1/2" below ground level if so desired. **Keep in mind that excessive ground engaging will rapidly decrease the life of the cutting hammers, sometimes as much as 50%.** When doing excessive ground engaged mulching, inspect the cutting hammers more often to prevent wearing the cutters into the holders.
- During mulching operations, it is the operator's responsibility to prevent debris from falling onto, or pushing against, the hoses that are connected to the cutter head. Allowing debris to pile up or fall onto the attachment can cause the hoses to break and/or wear excessively.
- **Never allow any riders on the cutting attachment!** This is a very dangerous practice and could cause serious injury and/or death.
- Rotating mulcher head will cause death and/or serious injury. Do not start up mulcher attachment until all personnel are **300 feet** from operation. Shut down the attachment when it is not in use.
- The operator should always be aware when mulching dead standing trees. There is a danger of the tops falling back onto the operators cab, causing injury or property damage.
- **Remember!** It is ultimately the operator's responsibility to know and understand **all** the aspects of operating this type of attachment.

PREVENTIVE MAINTENANCE

- Preventive maintenance is really just a simple matter of common sense. If you keep any piece of mechanical equipment clean, properly lubricated, and promptly replace any worn parts, you are going to “prevent” deterioration, as well as, promote long life, safe and productive service. The only other requisite to such a program is the regular scheduling of such maintenance.

WARNING!

Instructions are necessary before doing service on attachment. See warnings and instructions both at the beginning and throughout this manual. After doing service or making repairs or adjustments always check function of machine. Safety glasses or goggles are always required for eye protection from sparks, welding, battery acid, compressed springs, fluid under pressure, and flying debris or loose material when engines are running or tools are used. Use proper eye protection for welding and grinding. Failure to follow these general rules and warnings can cause injury or death.

SPECIAL NEW-MACHINE INSTRUCTIONS

- In addition to overall inspection of the machine, the torque of bolts and nuts should be checked and re-torque if necessary. Hydraulic fittings and hose connections should also be checked for tightness and leaks. If any leaks are found the O-ring should be replaced and retightened. The belt should be checked for the proper tension and retightened if necessary. See belt tension section page 27-28 of this manual.

MAINTENANCE

In severe conditions (extreme dust, heat, cold, humidity, etc.) you will need to service your machine more often.

Your working environment will impact the frequency of your servicing program.

Safety while servicing your machine is your responsibility. Only qualified and authorized personnel should be permitted to maintain, repair, adjust, and inspect the machine.

WARNING!

Always shut down machine and lower the cutting attachment to the ground before working on the machine.

WARNING!

Do not leave loose tools and rags on the machine. Ensure that all walking and climbing surfaces are clean.

WARNING!

Do not weld on any structural member unless specifically authorized by Magnum Systems Inc. Any unauthorized welding procedures will void warranty, and may cause structural damage and injury.

WARNING!

Do not support the attachment on cinder blocks, hollow tiles, or props that may crumble under a load. Do not work under a machine that is not properly supported.

WARNING!

The operator should be certain that all gauges are functioning properly to insure proper hydraulic protection.

CAUTION!

Check the hour meter regularly to determine when the machine needs periodic maintenance. Use the intervals on the Service Schedule except when operating conditions are extreme and abnormal. When operating in these conditions, shorter intervals must be used.

WARNING!

Do not exceed 15-PSI nozzle pressure when drying parts with compressed air. Do not direct compressed air against human skin. Serious injury could result.

CAUTION!

Use only recommended hydraulic oil in the oil reservoir. Other fluids will cause machine damage.

WARNING!

Make sure that all walking and climbing surfaces of machine are free of dirt, oil, debris, water, grease, and snow. Do not leave loose tools or rags on machine.

CAUTION!

Grease all pivot and cylinder points daily. Failure to follow manufacturers recommended daily maintenance procedures will cause premature component failure.

MAINTENANCE

WARNING!

Any unauthorized welding, alterations, additions or modifications made to Magnum machinery will void warranty. This attachment was designed to do a specific job and alterations could result in injury or property damage.

If Magnum authorized welding must be done, always keep the ground as close to the welding operation as possible. Never ground through any component or bearing assembly, as this will cause internal damage to parts.

CAUTION!

Whenever hydraulic oil is needed in the hydraulic system, the operator should refill to operating level before continuing work with the machine. Always be certain that the oil is clean and the fill hose is clean.

WARNING!

High-pressure hydraulic fluid can penetrate skin causing death, gangrene or other severe injury. Seek immediate medical attention to remove fluid.

- Keep hands and body away from areas ejecting fluid. Use a piece of cardboard to check for leaks. Wear proper hand and eye protection.
- Relieve pressure before loosening any hose or fitting connections.
- Tighten all connections before re-pressurizing system.

CAUTION!

Whenever doing preventive or required maintenance you should be very aware of cleanliness. The hydraulic systems on the Magnum Mulcher are designed to operate with clean oils. If it is necessary to change any parts, and open up any system, be very careful not to introduce dirt or debris into the system.

WARNING!

Do not operate or work on machine until you do the following:

- Read and understand machine manuals, safety decals, employer work rules, and applicable government regulations.
- Have been trained and are qualified in safe machine operation and maintenance.
- Consult your supervisor to explain any unclear instructions and warnings.
- Replacement manuals can be purchased from your Magnum dealer if they are lost or illegible.

WARNING!

Under no circumstance should any modifications be made to Magnum attachment without factory authorization. Any modifications will void the warranty. This attachment was designed to do a specific job and alterations could result in injury or property damage.

MAINTENANCE

In order to assure long machine life and low operating cost the following maintenance steps are critical.

WARNING Maintenance work should only be performed with the skid steer machine turned off and the mulching head resting on the ground.

1. At the end of each day all cutting residue should be removed from the machine as well as any dirt that may have accumulated.
2. Grease both ends of the rotor daily as indicated by the decal.
3. Check for loose or damaged teeth daily and tighten or replace if needed.
4. Check belt tension after the first 8 hours and then every 160 hours of operating time.
NOTE (See specific instructions for belt tightening, section 11)
5. Grease upper bearing housing every 160 hours of operation. **Note** (This is accomplished by removing the right hand upper cover plate.)
6. Check for loose hardware daily and tighten if necessary.
7. Check hydraulic hoses daily for any damage or leaks, tighten or replace as needed.
8. Check daily to make sure all hydraulic hoses are free of all machine pinch points and areas where they might rub and chaff.

Keep in mind frequency of maintenance depends on several things such as environment, operating method, age of machine, etc.

Every 6 months even if the machine is not being used all grease points should be lubricated in order to prevent the grease from drying out and requiring the unit to be disassembled to remove dried grease.

Should you notice any unusual vibrations while operating the machine, check to be sure all hammers are tight and in good condition. Check to see if there is any debris jammed into the rotor. Check to see if bearings are properly lubricated and in good condition. If vibration continues the rotor may need to be balanced. If balancing is required, contact your dealer. The Magnum 165 Mini-Mag Mulcher attachment should not be operated if there is a vibration that cannot be identified and repaired. Continued operation with a vibration is considered to be equipment abuse and could void all warranties that are associated with the 165 Mini-Mag Mulcher.

DAILY MAINTENANCE

There are two daily lubrication points that are noted by decals on either side of the 165 Mini-Mag Mulcher. Each one of these points must be greased with approximately 5 to 7 pumps per 10 hours of operation. See figure 1 and figure 2 below. In addition to the above, the operator should do a daily walk around to inspect for loose and or missing bolts. The hammers should be inspected daily for loose bolts, chipped or broken tips, or any cracks in welds on hammer holders.



Figure 1



Figure 2

WARRANTY RECOVERY POLICY

To take advantage of the Magnum Systems Inc. warranties you must follow the instructions below:

- (1) The mulching head must be delivered to the nearest Magnum Systems Dealer, where extent of the repairs will be determined. The warranty does not cover labor or transportation to and from the dealer location. All transportation costs are the responsibility of the user.
- (2) When returning a mulching head for repair the customer must have a copy of the invoice showing the date of purchase and the serial number.
- (3) It will be the customer's responsibility to furnish the dealer with a detailed description of the failure.

WARRANTY

GENERAL. These terms and conditions apply to all purchase orders accepted by the Seller, except as provided on the reverse hereof or by separate written instrument signed by the Seller (together the "Agreement"). "Equipment" shall mean the machinery, equipment, attachments, parts and accessories to be provided by the Seller as set out on the reverse hereof.

TITLE. Title to Equipment shall remain in the Seller until the purchase price and all costs and expenses arising hereunder are paid in full. Buyer agrees to execute all documents requested to establish and perfect Seller's security interest in the Equipment.

MANUFACTURER AND CREDIT APPROVAL. This Agreement is contingent upon acceptance by the manufacturer(s) of the subject Equipment and its component parts. This Agreement is also contingent upon credit approval.

CHANGING COSTS. Prices may be changed prior to delivery at any time such changes are made necessary by changing costs. Should Seller notify Buyer of an increase in the purchase price that equals or exceeds five percent (5%), Buyer shall have the option to rescind this Agreement in writing within thirty (30) days after Seller sends written notification of said price increase.

CANCELLATION. Buyer may cancel the Agreement within ten (10) days of Buyer's execution thereof. If Buyer cancels this Agreement thereafter, Seller shall be entitled to retain the down payment as liquidated damages. The parties agree that damages to the Seller caused by Buyer's cancellation would be difficult to ascertain and that this provision represents a reasonable approximation of such damages and not a penalty.

FORCE MAJEURE. If the supply of the Equipment by Seller, or the performance of any other obligation hereunder by any Party is prevented, delayed, interfered with or interrupted by fire, casualty, explosion, lightning, accident, strike, lockout, labor unrest, labor dispute, breakdown of machinery, plant or equipment, war (declared or undeclared), armed conflict, civil disturbance, riot, Act of God, delay of common carrier, inability to obtain materials or services, transportation, power, fuel, labor, or any other essential commodity or service, the enactment, issuance, or application of any law, local by-law, regulation, or executive, administrative, or judicial order, any local or national emergency, acts (including delay or failure to act) of any governmental authority, including, but not limited to, priorities, quarantines, embargoes, licensing controls, or production or distribution restrictions, inability to obtain or delay in obtaining required instructions, information, materials, or services, natural phenomena, including, but not limited to, weather conditions, floods, droughts, earthquakes, or epidemics, or any other cause or causes, or any other similar or different occurrence beyond the reasonable control of the affected Party (and whether or not foreseeable by such Party as of the date of execution of this Agreement) (collectively referred to herein as the "Force Majeure Events"), such prevention, delay, interference, or interruption shall be deemed not to be a default pursuant to this Agreement and the time(s) for such performance or supply thereunder shall be extended by the period(s) same is so prevented, delayed, interfered with, or interrupted.

Neither Party shall be required to change its usual business practices or methods or to assume or incur other than its usual costs or expenses in order to mitigate, avoid or eliminate any Force Majeure Event or to reduce the period of any resulting delay. Each Party shall notify the other Parties of any delay or failure excused by this paragraph and shall specify the revised performance date as soon as practicable. Nothing contained in this paragraph shall affect any obligation of Buyer to make any payment when due in accordance with this Agreement.

RISK OF LOSS. Place of delivery shall be F.O.B. Seller's facility, as identified on the reverse hereof. Seller's responsibility in the delivery of the Equipment ceases with delivery to the Buyer at Seller's facility or to a common carrier in marketable condition, which shall be conclusively presumed by a delivery receipt from the carrier. Identification shall occur and risk of loss shall be upon Buyer at the moment of delivery of the Equipment to a common carrier for shipment to Buyer.

PAYMENT. Buyer shall pay the purchase price upon notification that the Equipment is ready for shipment. If shipment is delayed at Buyer's request, Buyer shall pay the full amount of the outstanding purchase price of the Equipment ready for shipment. Buyer shall reimburse Seller for any additional expenses arising out of any such delay upon presentation of invoice for the same.

FREIGHT AND TAXES. Buyer shall be liable for direct payment of any freight, including storage, and for any federal, state or local taxes or assessment of any nature.

IN CASE OF DELAY CAUSED BY SELLER'S DEFAULT, SELLER SHALL IN NO EVENT BE HELD RESPONSIBLE OR LIABLE FOR CONSEQUENTIAL DAMAGE, INCLUDING BUT NOT LIMITED TO LOST PROFITS OR OTHER ANCILLARY DAMAGES. In case of delay caused by Buyer's failure to furnish necessary information, Seller may extend the date for shipment for a reasonable time, based on the period of Buyer's delay and conditions at Seller's facilities.

WARRANTY continued

LIMITED WARRANTY. Seller warrants that any Equipment or components manufactured by Seller and sold by Seller to Buyer as "new" shall be free from defective material and faulty workmanship for a period of one hundred and eighty (180) days commencing on the date of shipment of the Equipment to Buyer. In the event a Dealer is renting the unit out through its rental fleet, the warranty period starts upon first rental day. If it is determined that any Equipment manufactured by the Seller is defective and such defect is reported to Seller within one hundred and eighty (180) days, Seller will furnish at Seller's repair facilities during regular business hours such labor as is required for replacement or repair of said defective Equipment. This warranty shall not apply to the mulcher hammers or any other item normally consumed in operation or that has a normal life inherently shorter than twelve (12) months. Nor does this warranty apply to defects, damage or malfunctions in the Equipment resulting from: use of the Equipment in other than the normal and customary manner; misuse, accident or neglect by any person, or environmental conditions not conforming to Seller's technical specifications for the Equipment; unauthorized alterations or repairs to the Equipment, including but not limited to, use of unapproved parts in the Equipment; or any Force Majeure Event. Seller's liability pursuant to this paragraph shall cease if Buyer does not have inform Seller in writing of any such defect, damage or malfunction within ten (10) days after its first occurrence. Buyer shall not return the Equipment without Seller's prior written authorization and then only in accordance with Seller's instructions. Buyer shall bear the risk of loss and damage and all transportation costs for Equipment shipped to Seller. Warranty services performed under this paragraph shall not extend the warranty period. Any Equipment that is repaired or replaced shall be subject to warranty for the balance of the original warranty period or for ninety (90) days from the date the repair or replacement is completed, whichever is longer.

Any portion or component of the Equipment that is described as "New" and that is manufactured by a manufacturer other than Seller and sold by Seller to Buyer (the "OEM Equipment") shall bear only the warranty of such OEM Equipment manufacturer, to the extent that such warranty may be passed through or assigned to Buyer, and Buyer shall be subject to all limitations and requirements contained in such warranties. Seller will cooperate with Buyer to obtain adjustment from manufacturer for breach of any such manufacturer's warranty, any expense to be for Buyer's account. Any OEM Equipment requiring warranty services shall be returned to the respective OEM Equipment manufacturer by Buyer in accordance with the requirements of the warranty covering such OEM Equipment as passed through or assigned to Buyer.

SELLER SHALL IN NO EVENT BE LIABLE FOR DIRECT, INDIRECT, INCIDENTAL, SPECIAL, OR CONSEQUENTIAL DAMAGES, HOWSOEVER CAUSED, EVEN IF THE SELLER HAS BEEN ADVISED OF THE POSSIBILITY OF SUCH DAMAGES. THERE ARE NO OTHER WARRANTIES OF ANY SORT, EXPRESS OR IMPLIED, AS TO MERCHANTABILITY, FITNESS FOR PARTICULAR PURPOSE, TIME OF DELIVERY, OR ANY OTHER MATTER WITH RESPECT TO THE EQUIPMENT. THE WARRANTY PROVIDED ABOVE IS THE SOLE REMEDY OF BUYER FOR DEFECTS IN THE EQUIPMENT.

WITH RESPECT TO ANY EQUIPMENT SOLD AS "USED," BUYER TAKES ANY SUCH EQUIPMENT "AS IS" AND WITH ALL FAULTS OR DEFECTS UNLESS A MODIFICATION IS ENDORSED HEREON OR CONTAINED IN A SEPARATE WRITING SIGNED BY THE SELLER IN THE MANNER PROVIDED ON THE REVERSE SIDE HEREOF.

SELLER SHALL NOT BE RESPONSIBLE FOR ANY WARRANTY OR REPRESENTATION MADE BY BUYER TO ANY THIRD PART(IES) WITH RESPECT TO THE PERFORMANCE OF THE EQUIPMENT OR ANY PORTION THEREOF. BUYER SHALL INDEMNIFY AND HOLD HARMLESS SELLER FROM AND AGAINST ANY CLAIMS, DAMAGES, LIABILITIES, LOSSES, EXPENSES AND OBLIGATIONS ARISING OUT OF ANY WARRANTY OR REPRESENTATION MADE BY BUYER TO ANY SUCH THIRD PART(IES).

LIMITATION OF LIABILITY. In no event shall the cumulative liability of Seller to Buyer for any and all claims, damages, liabilities, losses, expenses or obligations, whether arising in contract, tort (including negligence regardless of degree of fault), strict liability, or otherwise, arising out of, connected with, or resulting from this Agreement or the manufacture, sale, license, delivery, resale, repair, replacement, or use of any Equipment, exceed the purchase price. Buyer shall have no right or remedy against Seller in the event of a breach by an OEM Equipment manufacturer of any warranty passed through or assigned to Buyer pursuant to this Agreement. Buyer's sole remedy with respect to the OEM Equipment shall be against such OEM Equipment manufacturer and not against Seller, and Buyer shall make all claims it may have directly to such OEM Equipment manufacturer in accordance with such OEM Equipment manufacturer's policies and procedures.

INSURANCE. Buyer shall, from the time of shipment of the Equipment until full payment, insure all of the Equipment against fire, windstorm, and extended coverage and shall provide Seller with a certificate of insurance for such insurance upon request.

TERMINATION. Any Party may terminate this Agreement, upon written notice, if the other Party files a voluntary petition in bankruptcy; such other Party is adjudged bankrupt; a court assumes jurisdiction of the assets of such other Party under a reorganization act; a trustee or receiver is appointed by a court for all or a substantial portion of the assets of such other Party; such other Party becomes insolvent or suspends its business; such other Party makes an assignment of its assets for the benefit of its creditors, except as required in the ordinary course of business; or the identity of such other Party's business is materially changed by sale of its business, transfer of control of its outstanding stock, merger or otherwise.

AMENDMENT. No alterations or modifications of this Agreement shall be binding on the Seller unless made in writing and signed by the Seller.

CONTROLLING TERMS. Should any of the terms and conditions of any Buyer's purchase order conflict or not be in accord with any of the terms and conditions herein, such conflicting terms and conditions shall be deemed rejected and the terms and conditions herein shall govern.

WAIVER: A Party's failure to enforce any of the provisions hereof, or to exercise any of its remedies pursuant to this Agreement, shall in no way be construed as a waiver of such provisions, rights or remedies, or in any way be deemed to affect the validity of this Agreement.

SEVERABILITY. If any of the provisions of this Agreement is declared invalid or unenforceable by a court of competent jurisdiction, such invalidity or unenforceability shall not invalidate or render unenforceable the entire Agreement, but rather the entire Agreement shall be construed as if not containing the particular invalid or unenforceable provision(s), and the rights and obligations of the Parties shall be construed and enforced accordingly.

GOVERNING LAW AND VENUE. This Agreement shall be governed by and solely construed in accordance with the laws of Florida. Exclusive venue of any dispute, claim, or cause of actions arising from or relating to this Agreement shall be the federal or state courts located in Hillsborough County, Florida.

ENTIRE AGREEMENT. This writing is intended by the parties as a final expression of their agreement and is intended as a complete and exclusive statement of the terms of their Agreement. All oral statements, representations, prior dealings between the parties and prior usage of the trade shall be superseded by the terms and conditions expressed in this Agreement.

CUTTING HAMMER INSTALLATION AND OPTIONS

- Our fixed tooth cutting hammer design is built to withstand the rigorous environments associated with land clearing activities across the globe. We have various Patent-Pending single and double-sided cutting hammer options available for specific geographic locations.
- These cutting hammers are manufactured using the very best tungsten carbide available, giving hundreds of trouble free hours of service before replacement is necessary.



**Single sided gapped hammer
(Patent-Pending)
Part # 600-112-1**

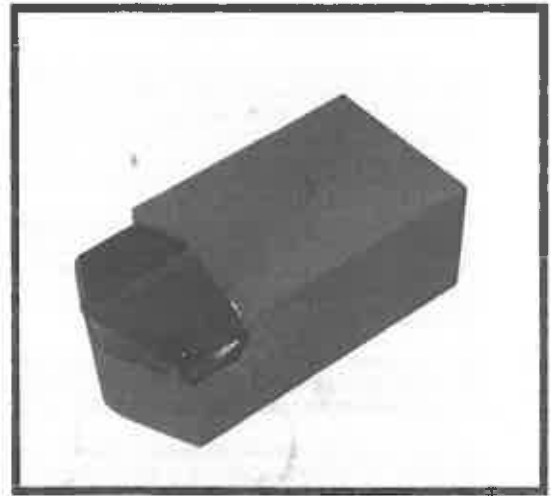

**Single sided rock hammer
(Patent-Pending)
Part # 600-108**

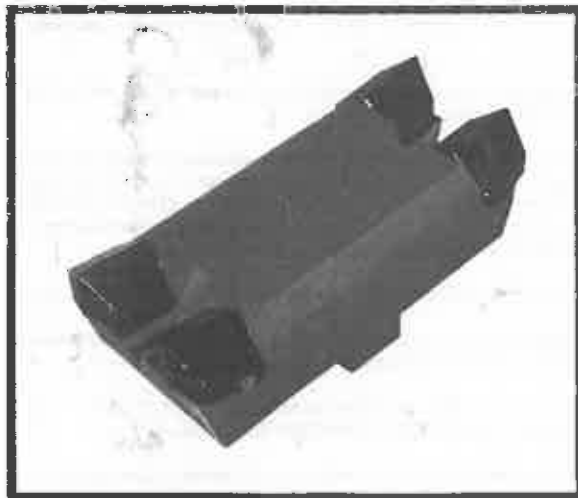

**Double sided gapped hammer
(Patent-Pending)
Part # 600-168**



**Double sided rock hammer
(Patent-Pending)
Part # 600-162**

All above hammers attach to an individual hammer holder, which allows the hammer replacement to be performed using an impact wrench. **The torque setting for tightening the bolts is 150 pounds.**

CUTTING HAMMER INSTALLATION

The following photos show the proper way to install a cutting hammer. Always make sure that the mounting surface and bolt holes for the hammer are clean and free of debris. Any accumulation of debris can cause the hammer not to seat properly in slot and will not be safe to operate. Bolts should be replaced if they show any wear on the threads or the bolt head. The washer should be replaced if the striations are worn off, or if the washer is cracked. When installing a new washer, the side that is higher in the center should be installed with the high center towards the bolt head. After both bolts have threads started into the cutting hammer, push the hammer up into the mounting slot, and then tighten both bolts with an impact wrench. **Failure to start both bolts into hammer first before tightening a bolt, can bind the other bolt, and damage threads on that bolt and possibly the cutting hammer, thus rendering the hammer and bolt unusable.** Only after all bolts are tightened to approximately 150 ft. lbs. of torque per bolt, will the 165 Mini-Mag rotor will be safe to operate.

Warning! Failure to follow this procedure could cause property damage, severe injury and/or death.

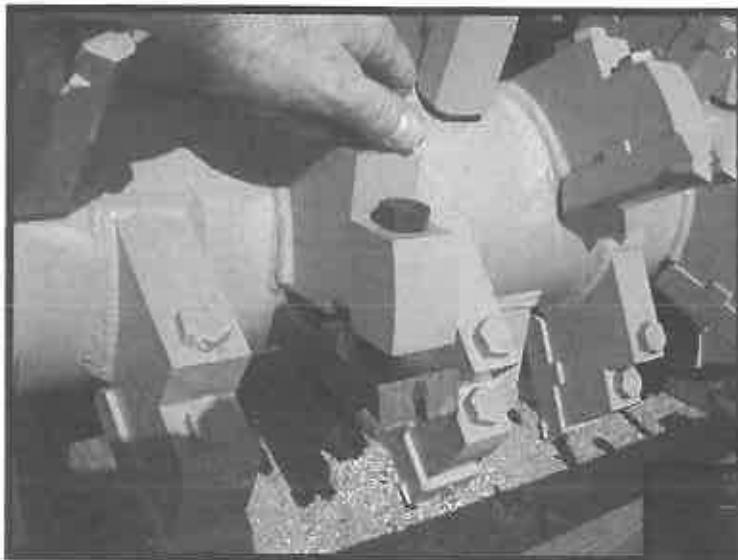

Start both bolts into hammer to insure proper thread start.

Hold hammer up into slot, then tighten.

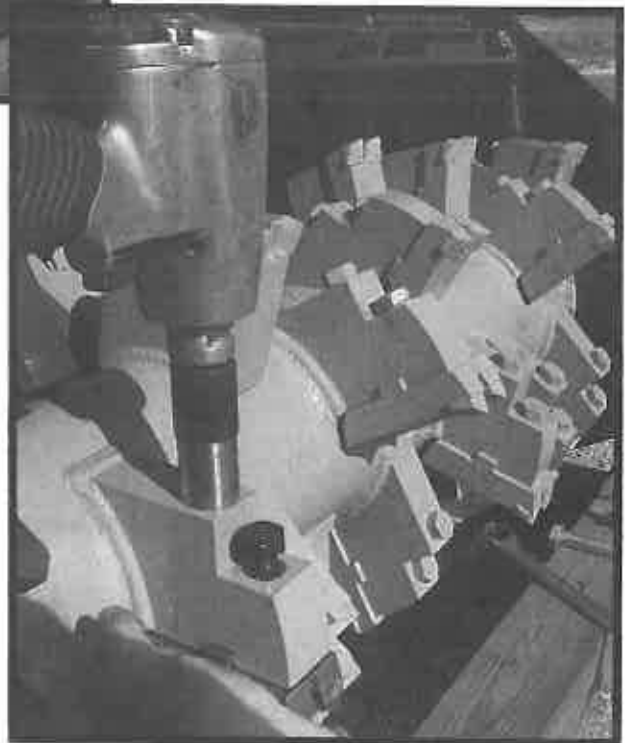

It is important that the hammers are attached properly and periodically checked (see maintenance requirements) using Magnum replacement parts only. Improper mounting or use of Non-Magnum parts can void warranty and cause serious injury and/or death.

ADJUSTABLE SKID PLATE

The 165 Mini-Mag Mulcher comes equipped with adjustable skid plates. The mulcher comes from the factory with the plates in top position (figure 1). They can be adjusted into the lower position by removing all seven bolts that hold the plates in place, lowering the plates to the bottom hole and reinstall the bolts back into the holes. These bolts should be torqued down to 106 ft lbs. By lowering the skid plates, the amount of hammer to ground impact can be reduced, thus increasing the life of the cutting hammers. The need to move the skid plates can be determined by what the final product should be after mulching is completed.

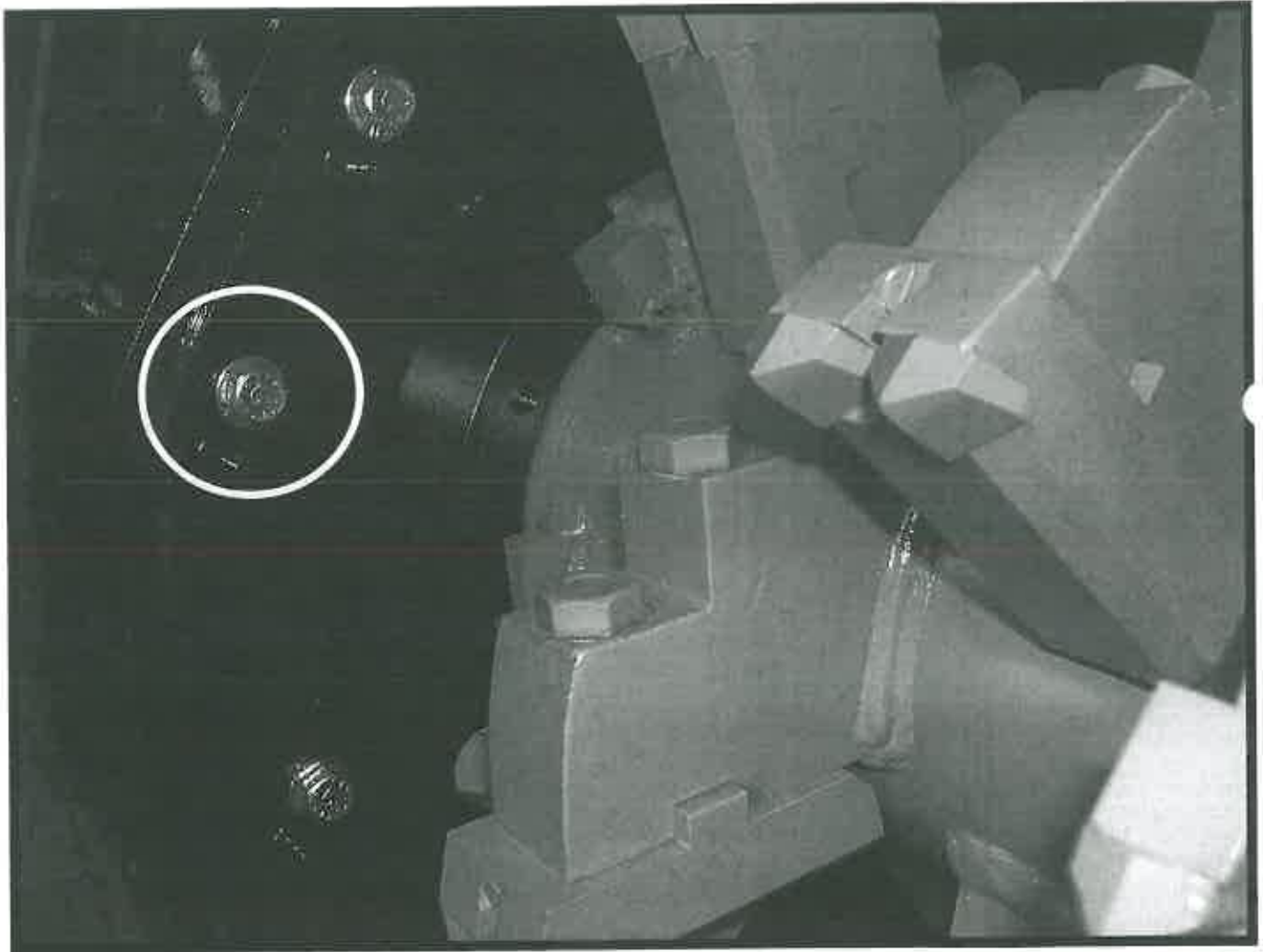

Figure 1

HYDRAULIC PRESSURE SIGHT GAUGE

The 165 Mini-Mag Mulcher is equipped with a pressure gauge (figure 1) that is visible from the operator seat. The gauge will show the operator what the hydraulic system pressure is operating at. The operator can operate the 165 Mini-Mag attachment based on the skid steer high flow system operating pressure. The pressure will go up as the machine is put into the work. Each skid steer carrier has a different maximum operating pressure, and the operator should know what that is, prior to operating machine. As the gauge approaches the maximum pressure, the operator should slow down the ground speed and/or raise the mulching head out of the work so as not to continuously operate the system at the maximum level. Running the machine at the maximum pressure levels can lessen the life of the hydraulic components. Knowing what the maximum operating pressure is and operating the attachment at below the maximum will allow the operator to become a more efficient operator and thus creating more production per operating hour.

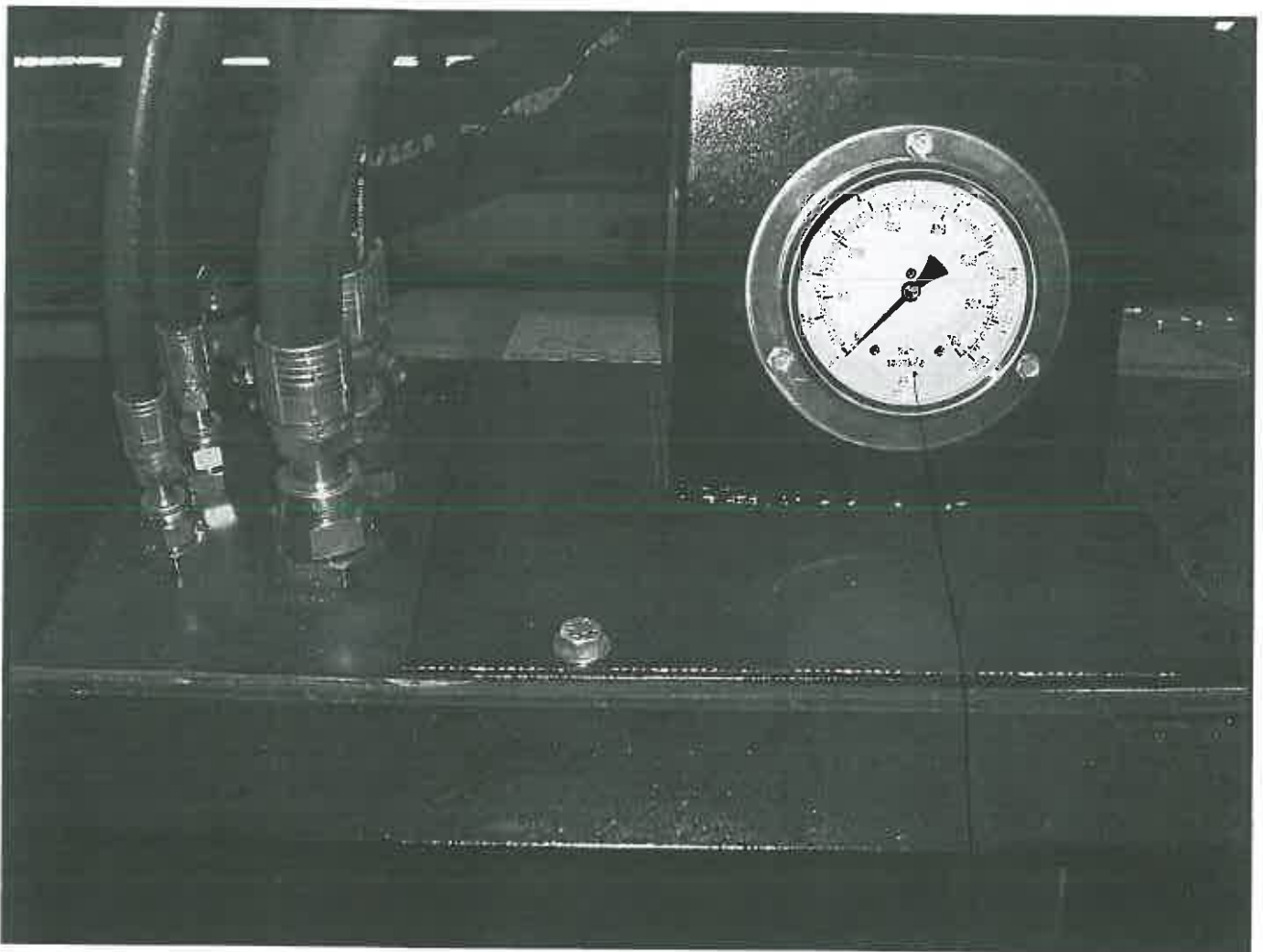

Figure 1

sight Gauge
200-155

PUSH BAR ADJUSTMENT

The 165 Mini-Mag Mulcher comes standard from the factory with an adjustable push bar attachment. The push bar is installed in the center position and can be adjusted to either a forward or back position. The push bar is easily adjusted (figure 1) by removing the two bolts at the rear of the mounts. After removing the two bolts the bar can be moved to the desired hole location and then the bolts reinstalled and retorqued to 250 ft lbs. The push bar can be adjusted to the front position to help push brush over when mulching strictly brush and no standing trees. The rear position is for mulching standing trees and little brush. If you need to mulch a standing tree when the push bar is in the front position, be certain to tilt the attachment back to prevent bending the push bar.

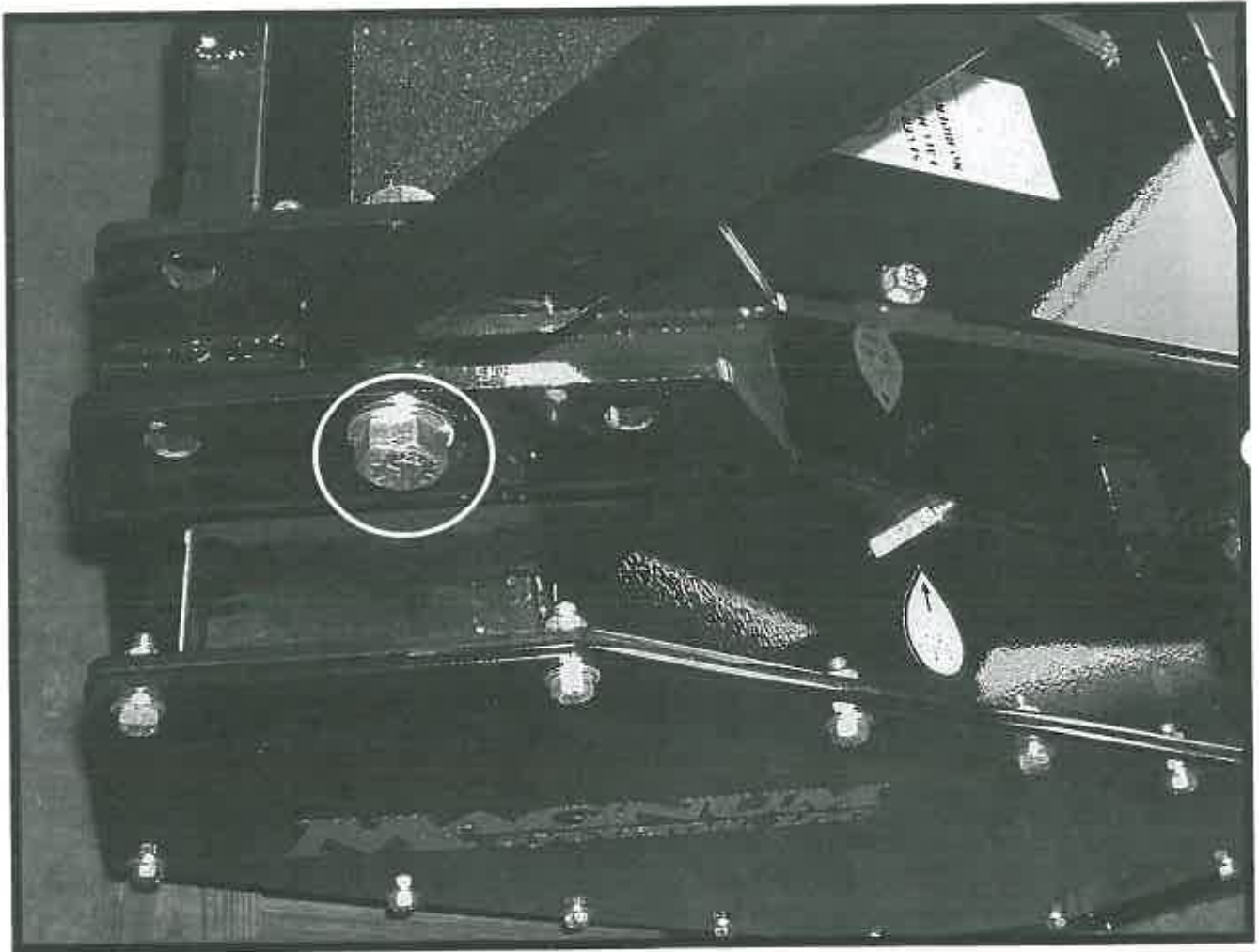

Figure 1

HYDRAULIC DEFLECTOR DOOR

The 165 Mini-Mag Mulcher comes from the factory with a hydraulic deflector door that is designed specifically for safety to deflect debris and mulched material towards the ground. Extreme caution should always be used when operating the attachment around other personnel. **Danger! There is always the possibility of debris escaping the front or the rear of the attachment, even if the deflector door is closed.**

When operating the attachment in a forward motion with the mulcher head engaged, the deflector door can be opened or closed. If the attachment is operated with the door closed, the operator must be very careful not to allow brush or standing trees to push on the deflector door. Heavy brush and/or standing trees will bend the door into the rotor and cause damage to the door and/or cutting hammers. It is best to operate the attachment with the door open (while mulching in forward direction) and use extreme caution when there are other personnel or property within **300 feet** of the operation. The deflector door can be closed or open while mulching in reverse direction. While mulching in reverse, debris will become dangerous projectiles if the door is left in the open position. If the door is in the closed position while mulching in reverse direction, debris will be directed down to the ground and produces a smooth clean looking finished product. It is best to keep the deflector door in the closed position while mulching in reverse direction. Ultimately, safety is the responsibility of the operator, and the operator should always be aware of there surroundings while operating the 165 Mini-Mag Mulcher at all times.

**Deflector
door open**



**Deflector
door closed**



BELT DRIVE

To check the belt tension, remove the belt cover on the right hand side of the mulching head by removing the thirteen bolts that hold it in place.



Once the cover has been removed, you can test the tension of the belt by checking the deflection in the belt (half way between the two pulleys, deflection is how far the belt moves up and down). With approximately (68 lbs. on a new belt or 50 lbs. on a used belt) of force, you should only be able to push the belt down about $\frac{1}{4}$ of an inch. The belt should not move more than .23 of an inch with either the 68 lbs. or the 50 lbs. of force (figure 1). The belt should not be so tight that you cannot move it at all.

.23" of deflection (up and down movement) @ 68 or 50 lbs. of force. (Figure 1)

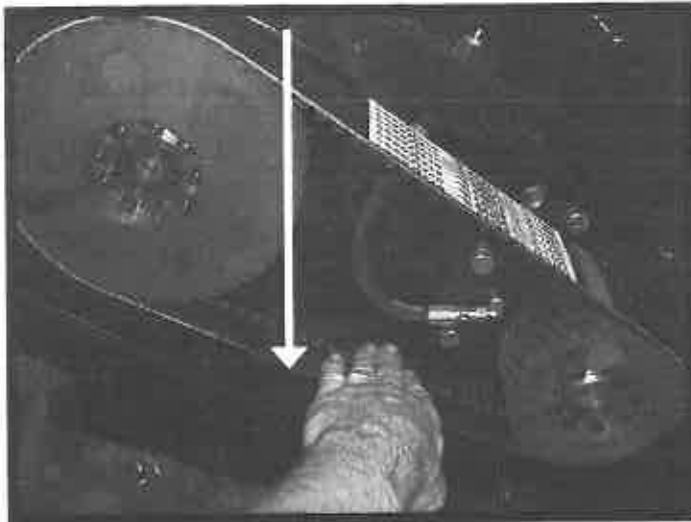

Figure 1

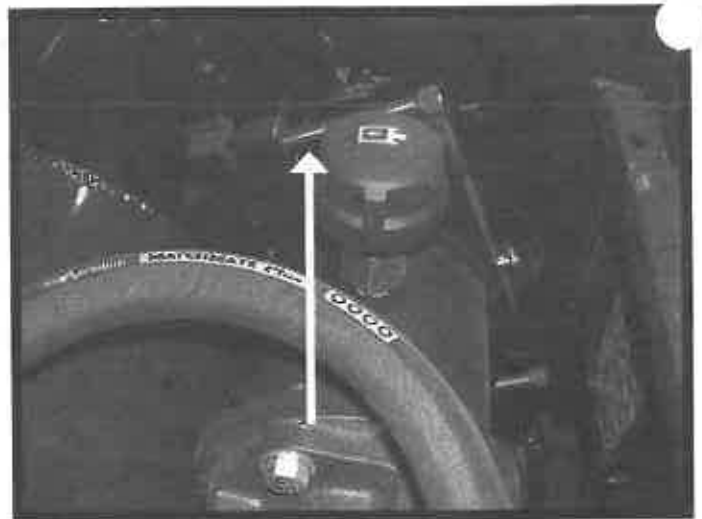

figure 2

The 2 tensioner bolts take a $\frac{3}{8}$ " allen to adjust (figure 2). The 2 bolts that hold down the bearing housing should be loosened slightly to allow the housing to slide in the slots. Then the 2 tensioning bolts should be tightened alternately to keep the housing from binding in the guides. The belt should be tightened until the belt is at the proper tension (section above), and then the housing bolts get tightened to 370 ft. lbs. of torque. The belt tension should be checked again after the housing bolts are tightened. There are three things that will destroy this type of belt — the belt being too tight, too loose, or debris getting into it. So it is very important that the proper tension is achieved and the belt cover be reinstalled before any mulching operations take place.

BELT DRIVE PULLEYS

The 165 Mini-Mag Mulcher is sold with one of two pulley options. The drive setup is installed depending on what the hydraulic flow and the engine horsepower of the carrier are. In the event that the pulleys must be removed, the following procedure must be followed:

Pulley removal

1. Remove the right top cover plate by removing all the bolts and then remove the hose for the gauge from the motor. When removing the hose from the motor, be certain that there is no pressure in the system. Also, make sure that the fittings are plugged off so as not to allow any dirt or debris to enter the hydraulic system.
2. Next remove the side belt cover by removing all the bolts.
3. The bushings that hold the pulleys in place should be loosened first. The following procedure should be followed for removal.
4. First remove all 9 bolts that hold the bushing together (item 2)
5. Then reinstall 8 of the bolts back into the holes that were not used previously (item 1)
6. At this time 4 bolts will be pushing the rear part of bushing apart (item 5) and 4 bolts will be pulling the front part of bushing out (item 4). Continue tightening the bolts around the bushing until it separates.
7. When both the front and rear portions of the bushing are apart, you will be able to remove the pulley.
8. Remove the rear access cover plate to gain access to the bottom bearing housing bolt and tensioner bolt.
9. The two bolts that hold the bearing housing in place need to be loosened and then the two tensioner bolts. Loosen these two bolts far enough that you can remove the belt.
10. Once the belt has been removed, the bushings that hold the pulleys in place can now be slid off the shaft along with the pulley.

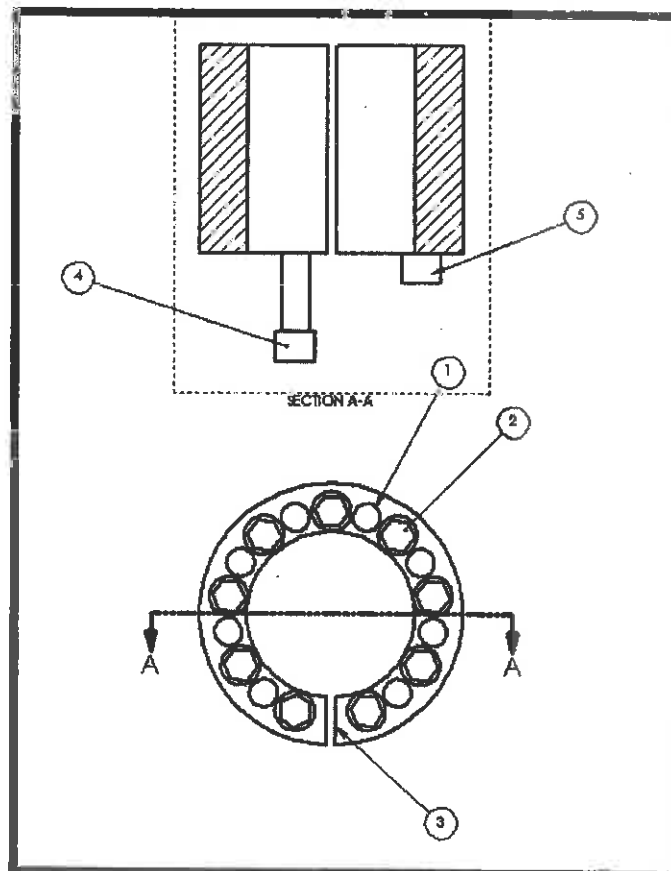

PULLEY INSTALLATION

1. Once the maintenance that required the removal of the pulley is complete, the following procedure to reinstall pulleys should be followed.
2. First, the two bolts that hold the upper bearing/motor housing in place have to be tightened to realign the shaft and housing. You can check for proper tightness and alignment by looking to see that the housing is properly seated flat against the sidewall of the mulcher head. If there are any gaps along this surface you will have to remove the housing, clean any debris from surface, reinstall and tighten, then recheck proper seating and alignment. This will properly position the housing and shaft in the position so that the pulleys can be correctly aligned.
3. The bushing needs to be reassembled for the proper installation. **Do Not** use any "Never Seize" on the bushing or bolts. Make sure that all the slots in all three pieces of bushing are aligned (item 3). Put all 9 bolts back into original holes (item 2). Once again check that all the slots are lined up. Loosen up all bolts so the 3 parts are loose. Take 2 bolts, insert one into a push out hole (item 5), one into a pull out hole (item 4), and hand tighten, separating the 3 collars. This will allow you to be able to push the complete assembly into the pulley and slide the pulley/bushing assembly onto the shaft. If you are having difficulty sliding on the shaft or into bore then you have the bushing too tight. Loosen the bolts a little more and tighten both the push out bolt and the pull out bolt.

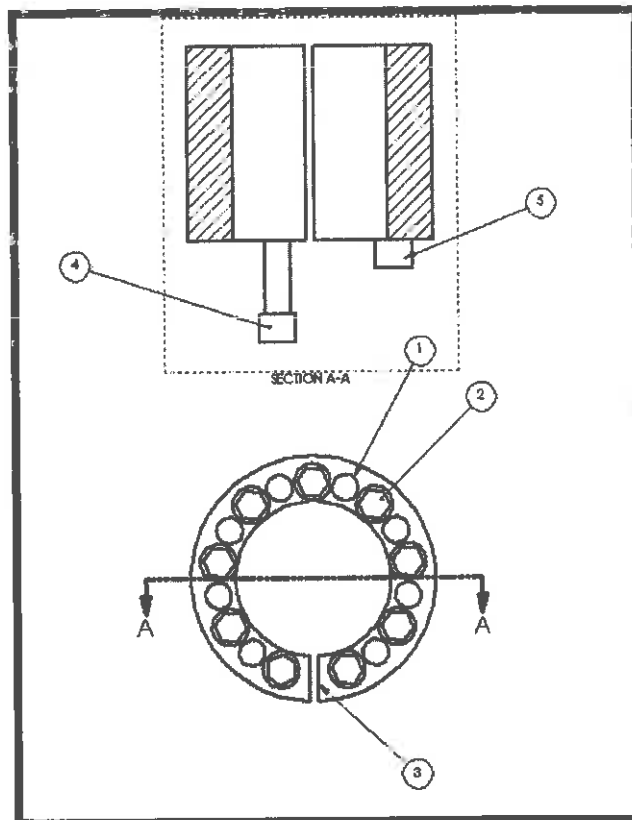

PULLEY INSTALLATION continued

4. After the assembly is on the shaft and the pulley is installed (note: pulleys are directional, make sure they both are pointing in the same direction), make sure the bushing is in the center of the pulley and the shaft is all the way thru the bushing.
5. If both pulleys were removed, install the second one using the same procedure. Once both pulleys are on the shaft and belt is installed, check to be sure that there is no interference with any of the covers, fittings, bolts or hoses.
6. Remove the 2 bolts that were used for the push and pull bolts and reinsert them into the proper holes for tightening. After all the alignment and clearance steps are completed you can hand tighten the bolts to keep bushing and pulley from moving.
7. To align the second pulley with the first you will need a straight edge. The outside edge of both pulleys should be aligned. Failure to align the outside edges of the pulleys will destroy the belt when the machine is put into operation.



8. Now you can tighten the belt. Loosen the 2 bolts that hold the bearing housing in place enough so the housing will slide in slots. Using the tensioner bolts tighten the belt. Tighten the belt just enough to hold the pulleys and then torque the bolts inside the pulley bushing.
9. The bolts should be torqued to 30 lbs. Set the torque wrench to approximately 5% higher than the required setting. Tighten locking bolts in sequence around the bushing using only $\frac{1}{4}$ turns for several passes until $\frac{1}{4}$ turns can no longer be achieved. Continue to apply over torque to bolts for 2 more passes and then reset the torque wrench to 30 lbs. And then recheck all bolts to be sure that they are torqued to proper setting
10. The tightness of the belt depends on if it is new or used. The belt should be tightened so the deflection force, which is 68 lbs. pressure for a new belt and 50 lbs. pressure for a used belt (amount of pushing pressure that it takes to move the belt approximately $\frac{1}{4}$ of an inch). Once the proper tension is achieved, you can retighten the bearing housing bolts that hold housing against the sidewall of mulcher head. After tightening the 2 bolts, double check the belt tension to be sure that the belt is not too tight or too loose. Also, refer to the belt adjustment section for additional information.
11. Replace the belt guard cover plate using the bolts that were removed. Replace the top cover plate using the bolts that were removed. Do not operate the mulcher attachment without reinstalling the belt guard cover plate.
12. Replace the rear cover access plate using the bolts that were removed. The machine is now ready for operation.

Hydraulic Motor

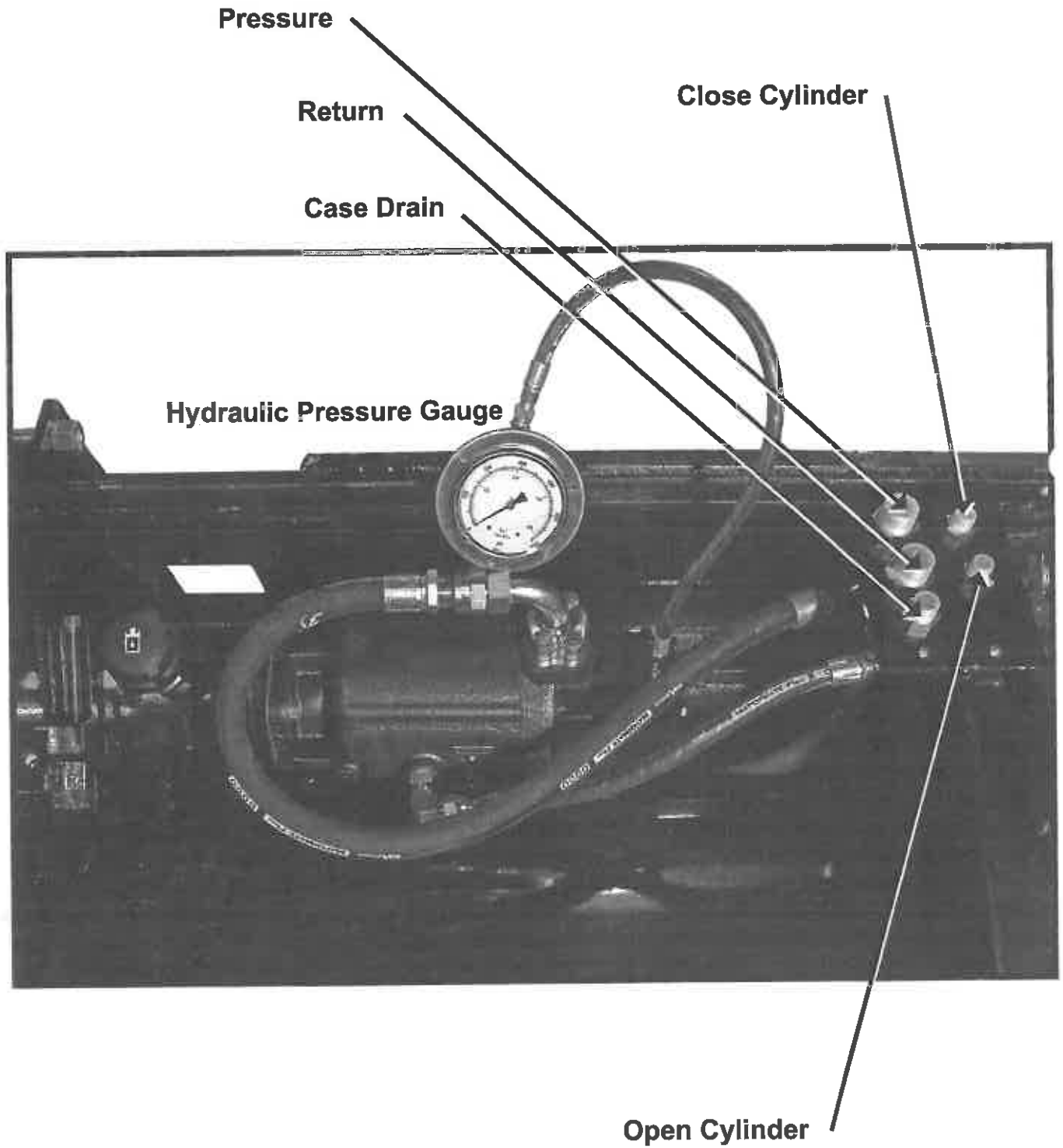

UPPER BEARING HOUSING

The upper bearing housing is filled with Premium gear oil 80W90. In the event that gear oil is needed, there is a fill level plug on the backside of the housing (figure 1). To fill housing to the proper level, remove the plug and then remove the breather (figure 2) from the top of housing. Fill the housing until there is oil coming out of the level hole (figure 1). Then replace the plug fitting and the breather.

The grease fitting on the upper housing should be greased at least once every 80 hours with 3 pumps of grease.

Figure 1

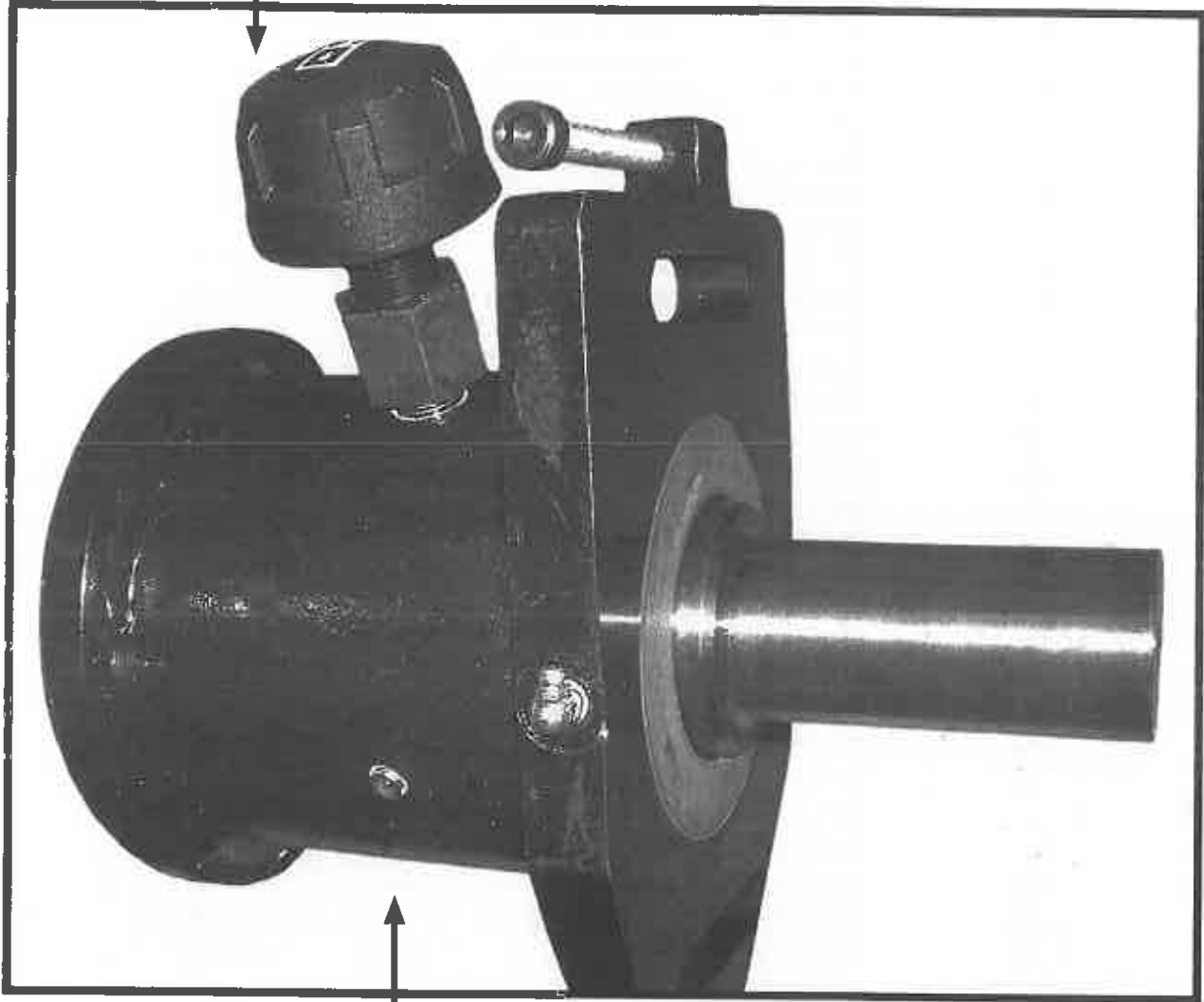

Figure 1

7 Kerkoth motor
 200-669
 45991 - output shaft seal

UPPER BEARING HOUSING and HYDRAULIC MOTOR

Upper bearing housing and hydraulic motor parts breakdown (see detail A page 35)

Item no.	Part no.	Description	Quantity
1 EATON	200-6433-115	Hydraulic drive motor	1
2	700-A662	Bolt	4
3	700-88439	Flat washer	4
4	201-375	Fitting	1
4A	201-203	ORB O-ring	1
4B	201-195	ORS O-ring	1
5	203-228	Hose assembly	1
6	201-346	Fitting	1
4B	201-195	ORS O-ring	1
7	203-231	Hose assembly	1
8	201-305	Fitting	1
4B	201-195	ORS O-ring	1
8A	201-201	ORB O-ring	1
9	203-225	Hose assembly	1
10	201-143	Flange kit	1
10A	201-208	Flange O-ring	1
11	201-277	Fitting	1
11A	201-196	ORS O-ring	2
12	203-229	Hose assembly	2
13	201-354	Fitting	1
4A	201-203	ORB O-ring	1
11A	201-196	ORS O-ring	1
14	201-138	Fitting	1
10	201-143	Flange kit	1
10A	201-208	Flange O-ring	1
15	203-226	Hose assembly	1
11	201-277	Fitting	1
11A	201-196	ORS O-ring	2
12	203-229	Hose assembly	1
13	201-354	Fitting	1
4A	201-203	ORB O-ring	1
11A	201-196	ORS O-ring	1
16	201-306	Fitting	1
16A	201-200	ORB O-ring	1
16B	201-193	ORS O-ring	1

UPPER BEARING HOUSING and HYDRAULIC MOTOR continued

Upper bearing housing and hydraulic motor parts breakdown continued (see detail A page 35)

Item no.	Part no.	Description	Quantity
17	801-291	Bearing housing (upper)	1
18	700-115	Adjustment bolt	2
19	700-A717	Bolt	2
20	801-323	Washer	2
21	700-6203	Grease fitting	1
22	201-312	Plug fitting	1
23	201-366	Adapter	1
24	201-134	Breather	1
25	600-152	Seal (upper housing)	2
26	800A057	Drive shaft	1
27	600-154	Bearing cup	2
28	600-153	Bearing cone	2
29	600-155	Tongue washer	1
30	600-157	Locknut	2
31	600-156	Lock washer	1
32	203-238	Hose assembly (gauge)	1

UPPER BEARING HOUSING and HYDRAULIC MOTOR continued

EATON

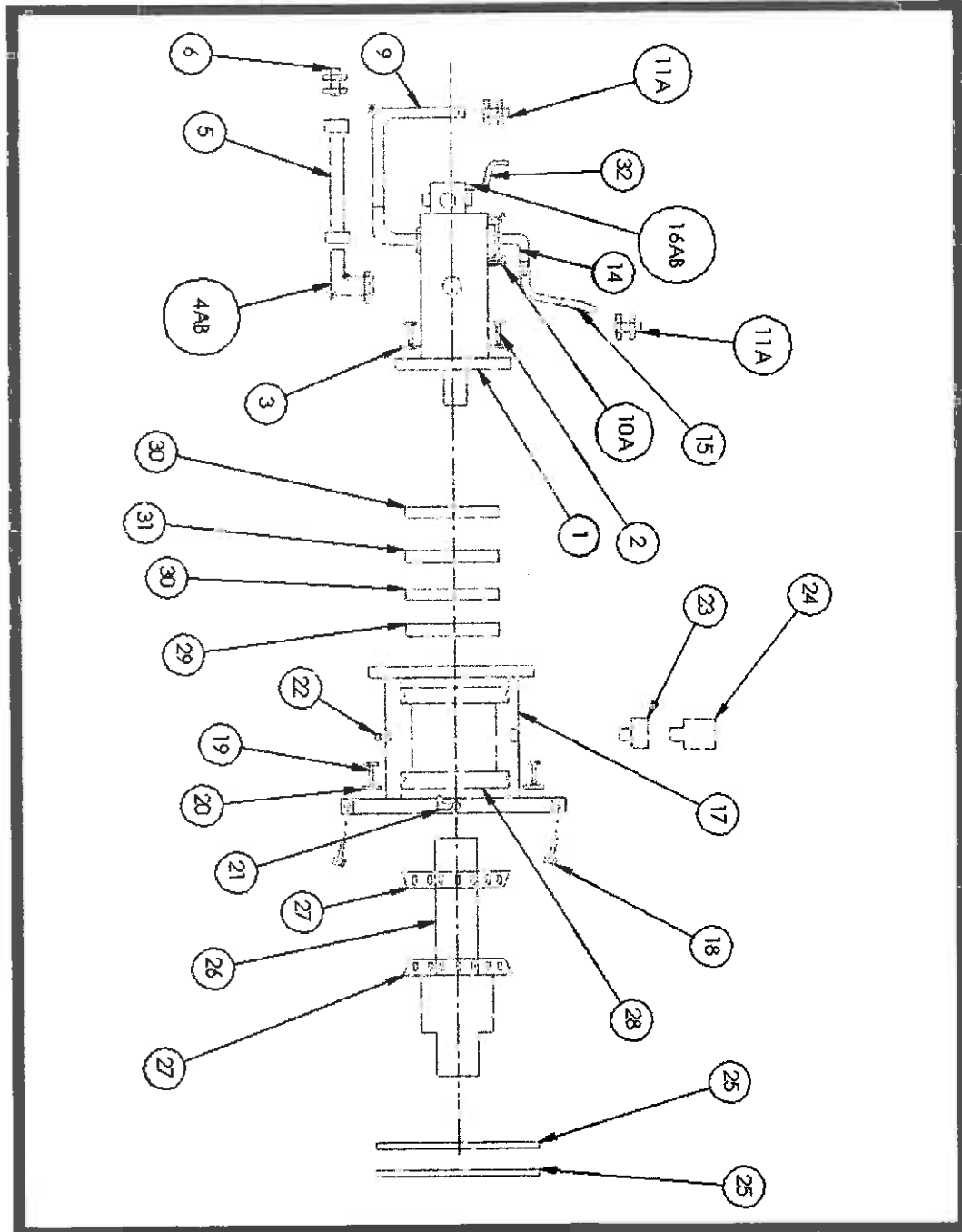

Detail A

LOWER BEARING REMOVAL

In the event that the bearings need to be removed from the rotor, the following procedure should be followed:

1. If the bearing that needs to be removed is on the drive side of machine, you will need to follow the pulley removal procedure first to get into the bearings.
2. If the bearing is on the drive side, the grease line will need to be disconnected and the line plugged and the fitting capped so as to prevent dirt from entering the system.
3. The outside seal cover plate comes off first by removing the four allen head bolts. Use two $\frac{1}{4}$ -20 x at least 1" bolts in the two push off holes to remove plate.
4. The locking tab must be located on the bearing lock nut and then bent out of the lock nut prior to removal of the nut. Failure to bend out the lock tab can result in breaking the lock ring and/or destroying the threads on the taper lock inside the bearing.
5. Once the tab is bent out you can safely loosen the lock nut and remove. The taper will need to be released from the bearing by pushing the taper lock back inside the bearing. Once the taper is released remove the 8 bolts that hold the bearing housing in place.
6. After the housing is removed from the machine, the inside seal cover plate will have to be removed. Once the cover is removed, slide the bearing out of the back of the housing.
7. Clean and inspect the housing for defects before installing a new bearing.

Bearing Installation

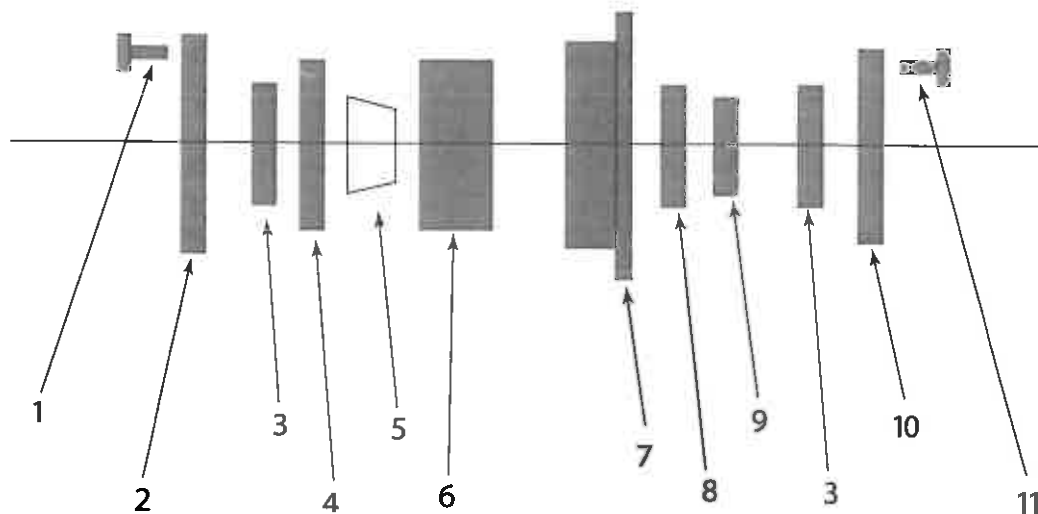

1. 700-64145 bolt
2. 801-207 inner seal cap plate
3. 600-159 seal
4. 801-303 spacer ring
5. 600-160 bearing adapter
6. 600-158 bearing
7. 801-288 flange assembly
8. 600-160 lock ring (Part of item #5)
9. 600-160 locknut (Part of item #5)
10. 801-206 outer seal cap
11. 700-64111 bolt

BEARING INSTALLATION

Continued

1. Once you are ready to reinstall the bearing check to see which side of the bearing is the smaller side of the taper. The smaller side of the bearing goes to the outside of the housing. Once the bearing is inside the housing, slide the bearing adapter into the bearing. First remove the locknut and the lock ring from the adapter, insert adapter into the bearing, reinstall the lock ring and locknut loosely onto the adapter. Finally, install the spacer ring into the housing.
2. Install a new seal into the seal cap and apply some gasket sealer to the outside edge of the bearing seal cap and install onto the housing using the bolts that were removed.
3. If the rotor was completely removed then you must first replace the two alignment bolts into the dirt ring.
4. This complete bearing housing can now be slid onto the rotor shaft, taking care not to damage the seal on the back of housing.
5. Reinstall the 8 bolts that hold the housing in place and torque to 106 lbs.
6. If both bearings were removed, only after both housings are installed, will you be able to tighten the bearing adapter.
7. Before you tighten the bearing adapter, check to be certain that the rotor is centered in the head.
8. Once the rotor is centered in the head you can tighten the bearing adapters on both sides to 250 lbs.
9. After the bearings are tightened, double check that the rotor spins freely in the head.
10. After torquing the bearings to 250 lbs. Locate the lock tab on the lock ring and bend into a slot. If no slots are in alignment, tighten the bearing to align a slot.
11. Reconnect the grease line and pump grease into the line to be sure grease is coming thru the bearing.
12. Apply some gasket sealer the outer seal cap and install to the housing using the 4 bolts that were removed.
13. Grease the bearings and reinstall belt and pulley following the belt and pulley installation procedure.

LOWER BEARING HOUSING and ROTOR

Lower bearing housing assembly and rotor (see detail B page 38).

Item no.	Part no.	Description	Quantity
1	700-64145	Bolt	4
2	700-97728	Breather	1
3	801-207	Outer seal cap	1
4	600-159	Seal	2
5	700A664	Bolt	8
6	700-58096	Lockwasher	8
7	700-6200	Grease fitting	1
8	801-288	Bearing housing flange	1
9	600-160	Locknut (part of item #15)	1
10	600-160	Lock ring (part of item #15)	1
11	600-158	Bearing	1
12	801-303	Spacer ring	1
13	801-206	Inner seal cap	1
14	700-64111	Bolt	8
15	600-160	Bearing adapter	1
16	801-210	Dirt ring	1
17	700-111 <i>lower</i>	Bolt (Model 165-5) <i>4 3/4 overall length</i>	45
		Bolt (Model 165-6)	54
18	700-114	Bolt (Model 165-5) <i>3 7/8 overall length</i>	45
		Bolt (Model 165-6)	54
19	<i>USE 2535</i> 700-109	Washer (Model 165-5)	90
		Washer (Model 165-6)	108
20	600-168	Hammer (shown, reversible double tip) (Model 165-5)	45
		Hammer (shown, reversible double tip) (Model 165-6)	54
20A	600-112-1	Hammer (double tip single) (Model 165-5)	45
		Hammer (double tip single) (Model 165-6)	54
20B	600-108	Hammer (rock tip single) (Model 165-5)	45
		Hammer (rock tip single) (Model 165-6)	54
20C	600-162	Hammer (rock tip reversible) (Model 165-5)	45
		Hammer (rock tip reversible) (Model 165-6)	54
21	800A072	Rotor assembly (Model 165-5)	1
21	800A054	Rotor assembly (Model 165-6)	1

Teeth

LOWER BEARING HOUSING and ROTOR

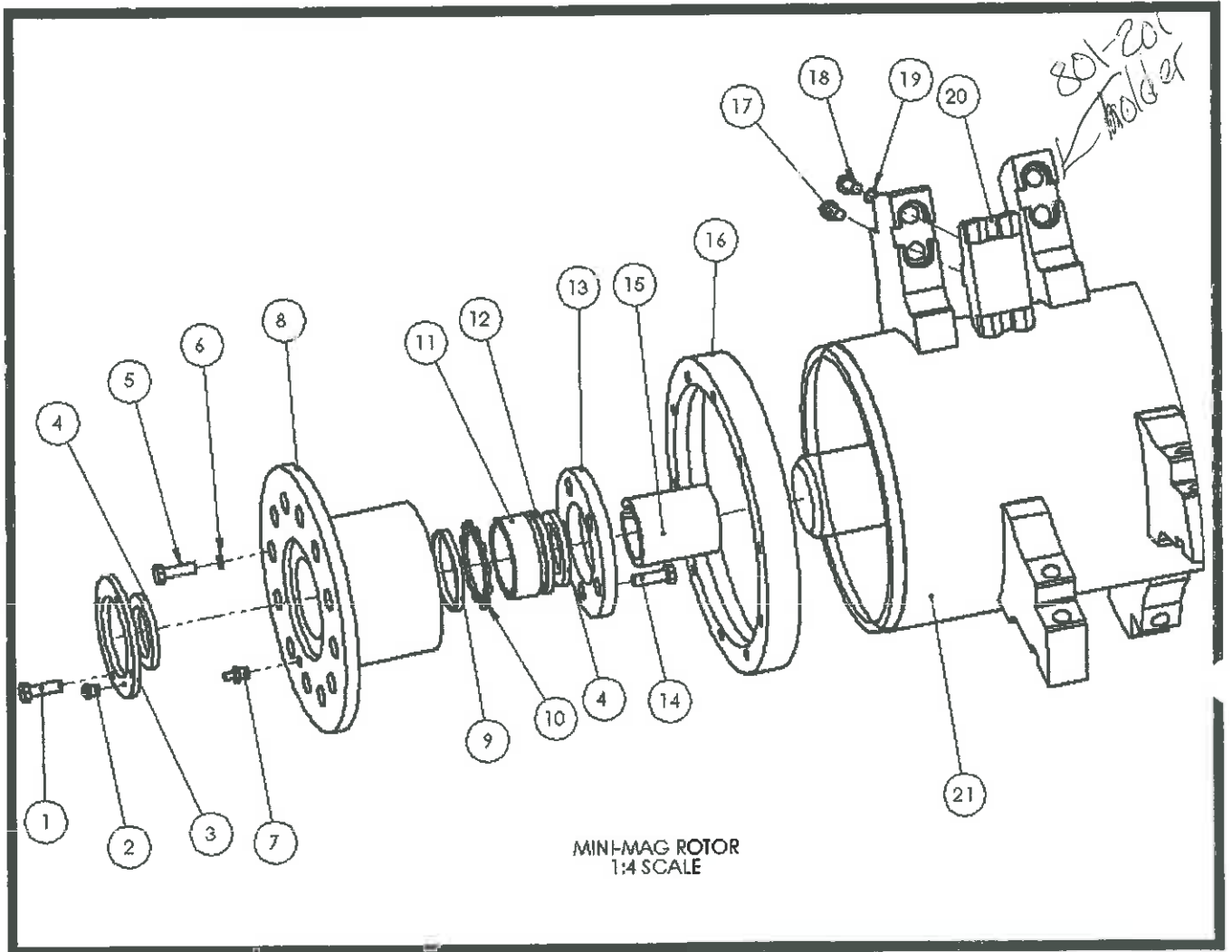

Detail B

MULCHER HEAD PARTS

Breakdown

Mulcher head assembly parts (see detail C page 41):

Item no.	Part no.	Description	Quantity
1	800A056	Head assembly (Model 165-5)	1
1	800A055	Head assembly (Model 165-6)	1
2	800A074	Headache rack assembly (Model 165-5)	1
2	800A075	Headache rack assembly (Model 165-6)	1
3	700-A724	Bolt	2
4	700-88442	Flat washer	4
5	700-80934	Locknut	2
6	800A070	Adjustment post assembly	2
7	700-A723	Bolt	2
8	700-A724	Bolt	2
9	700-80934	Locknut	4
10	700-88442	Flat washer	8
11	800A073	Deflector door (Model 165-5)	1
11	800A076	Deflector door (Model 165-6)	1
12	801-244	Hinge pin	3
13	700-1031	Cotter pin	6
14	800A066	Right side skid plate assembly	1
15	700-A663	Bolt	7
16	700-88439	Flat washer	14
17	700-80931	Locknut	7
18	800A065	Left side skid plate assembly	1
15	700-A663	Bolt	7
16	700-88439	Flat washer	14
17	700-80931	Locknut	7
19	801-219	Side plate filler	2
20	800A047	Shaft removal plate assembly	1
21	700-A632	Bolt	4
22	700-88437	Flat washer	4
23	800A042	Left side cover plate assembly (Model 165-5)	1
	800A043	Left side cover plate assembly (Model 165-6)	1
24	700-A632	Bolt	5
21	700-A633	Bolt	3
22	700-88437	Flat washer	8
26	801-308	Door cylinder seal	1
27	801-309	Door cylinder seal bracket	1
21	700-A633	Bolt	4
22	700-88437	Flat washer	4
29	800A039	Right side cover plate assembly (Model 165-5)	1

(Model 165-5)

MULCHER HEAD PARTS Breakdown continued

Mulcher head assembly parts (see detail C page 41):

Item no.	Part no.	Description	Quantity
29	800A040	Right side cover plate assembly (Model 165-6)	1
24	700-A632	Bolt	5
21	700-A633	Bolt	3
22	700-88437	Flat washer	8
30	<u>200-155</u>	Pressure gauge <i>sight Gauge</i>	1
31	801-324	Pressure gauge gasket	1
32	700-53664	Screw	3
33	201-388	Gauge fitting	1
34	203-238	Hose assembly	1
35	801-227	Belt guard cover plate	1
21	700-A633	Bolt	13
22	700-88437	Flat washer	26
36	700-80929	Locknut	13
37	801-318	Name plate	1
38	801-319	Serial number plate	1
39	700-117	Rivet	10
40	MS165-00-05	Decal kit	1
41	801-260	Safety chain (Model 165-5)	62
41	801-260	Safety chain (Model 165-6)	74
42	801-320	Chain holder rod (Model 165-5)	1
42	801-320	Chain holder rod (Model 165-6)	1
Drive pulley options (low flow 30 to 34 gallons)			
43	600-205	Drive pulley	1
44	600-206	Driven pulley	1
45	600-150	Pulley locking bushing	2
46	600-209	Belt	1
Drive pulley options (high flow 35 gallons and up)			
43A	600-211	Drive pulley	1
44A	600-210	Driven pulley	1
45	600-150	Pulley locking bushing	2
46	600-209	Belt	1
47	201-262	Fitting	1
48	201-263	Fitting	1
49	203-112	Hose assembly	1

MULCHER HEAD PARTS Breakdown

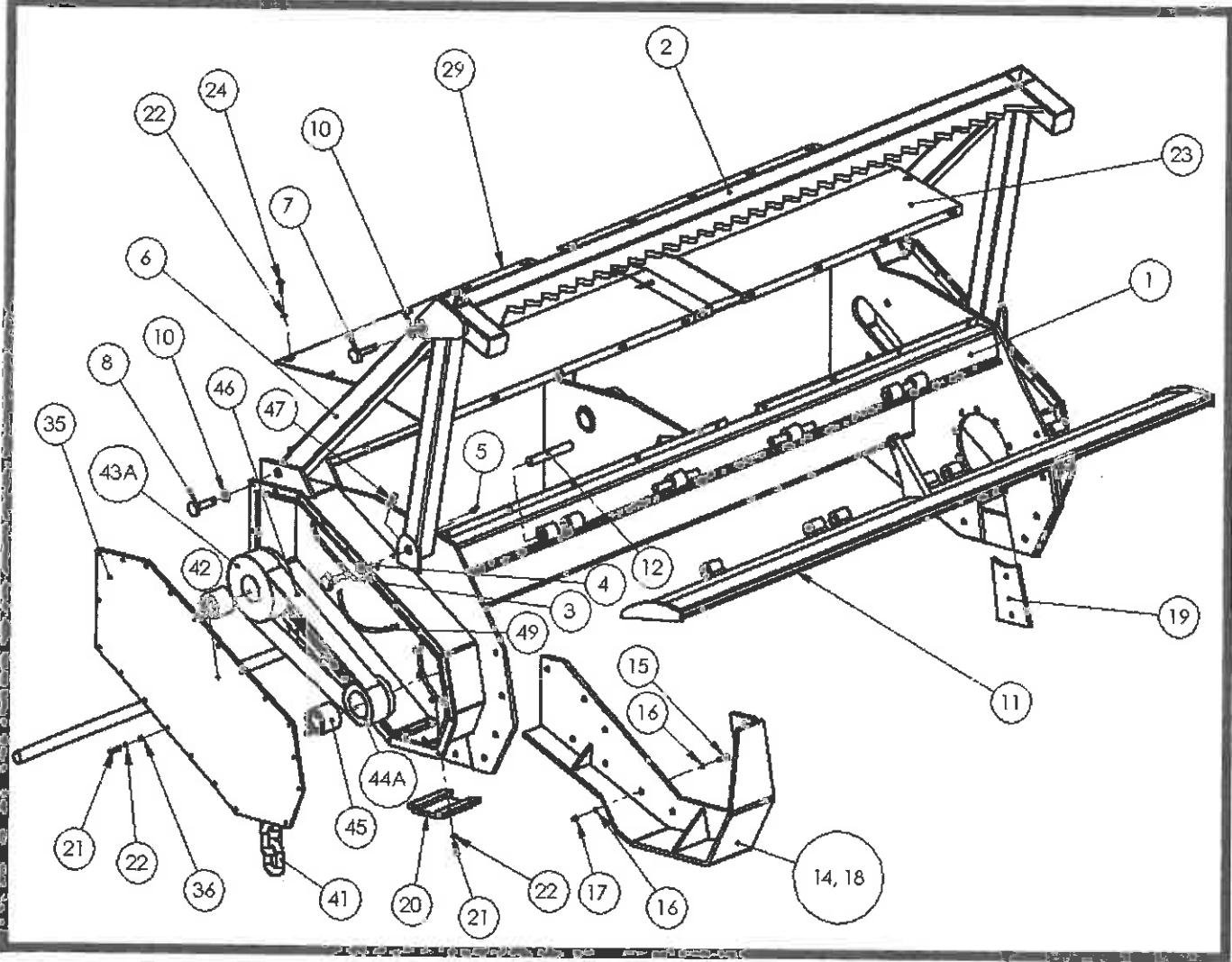

Detail C

DEFLECTOR DOOR PARTS

Deflector door cylinder assembly parts:

Item no.	Part no.	Description	Quantity
1	200-149 107209	Cylinder	1
2	201-173	Fitting	2
2A	201-194	ORS O-ring	8
3	203-227	Hose assembly	2
4	201-144	Fitting	2
5	203-230	Hose assembly	2
6	202-080	Hose protector wrap	1
7	201-113	Fitting	2
7A	201-202	ORB O-ring	2
8	700-53535	Pin	2
9	700-1061	Cotter pin	4

