

AGRICULTURAL MACHINERY

**sitrex**®  
Spa

**ASSEMBLY, USE AND MAINTENANCE  
SPARE PARTS LIST**

**RT/5800-H**

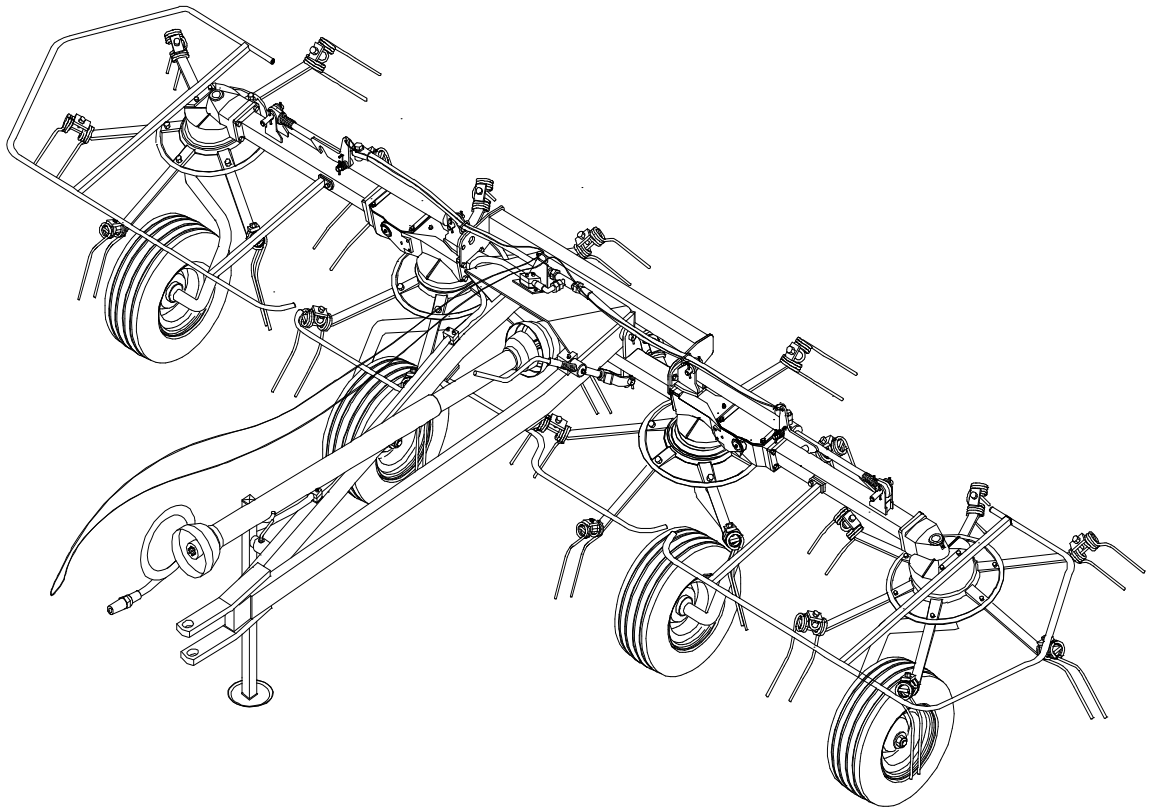

**ROTARY TEDDER**

10/06

# **SPARE PARTS LIST**

FOR CORRECT SPARE PARTS ORDER IT IS NECESSARY TO SPECIFY:  
TABLE NUMBER, ITEM, PART NO, DESCRIPTION AND QUANTITY OF  
PARTS REQUIRED.

ITEMS DESCRIBED AS RH AND LH ARE MEANT FACING REAR OF  
MACHINE.

RT/5800-H  
HYDRAULIC LIFT VERSION

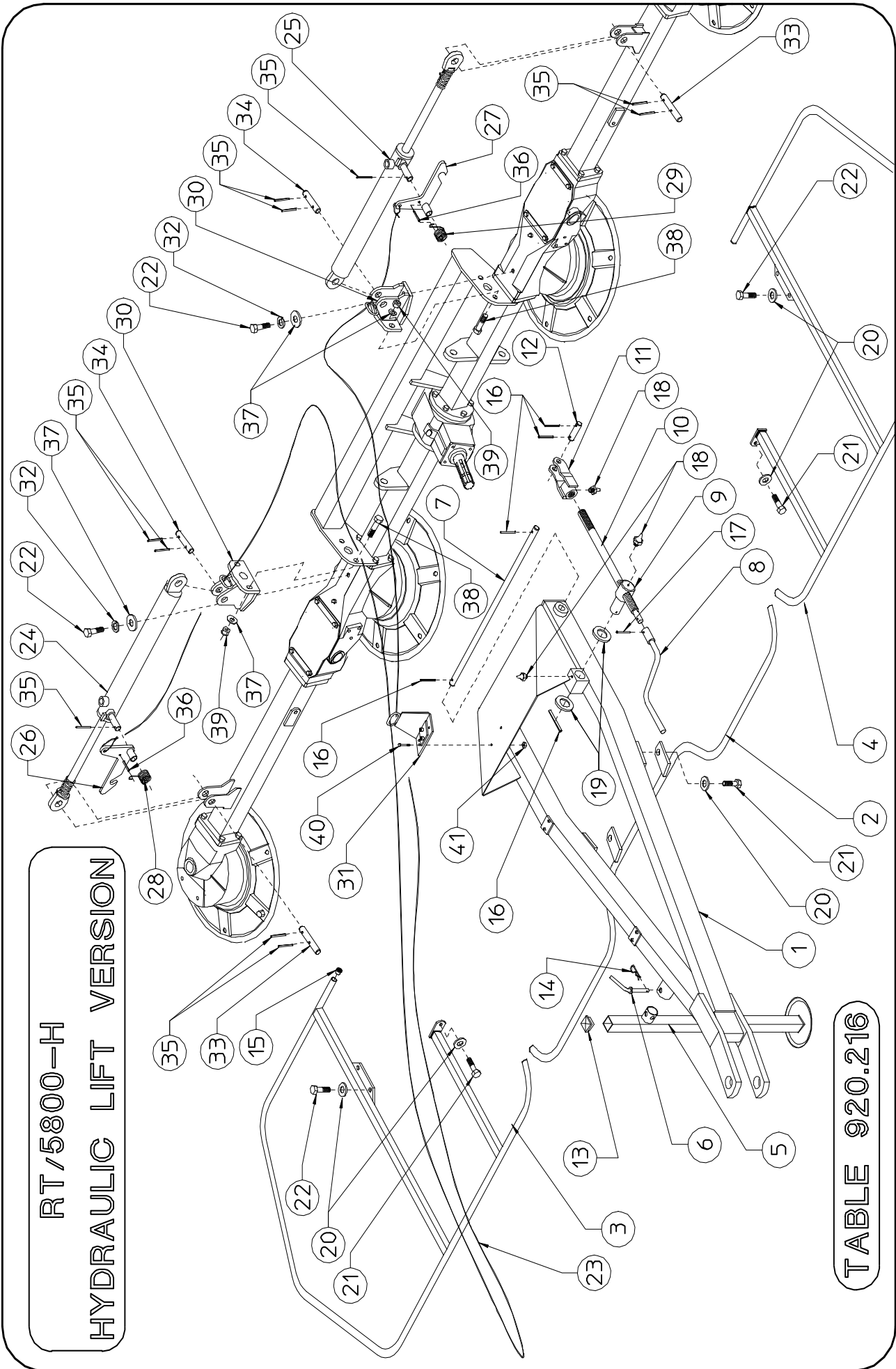
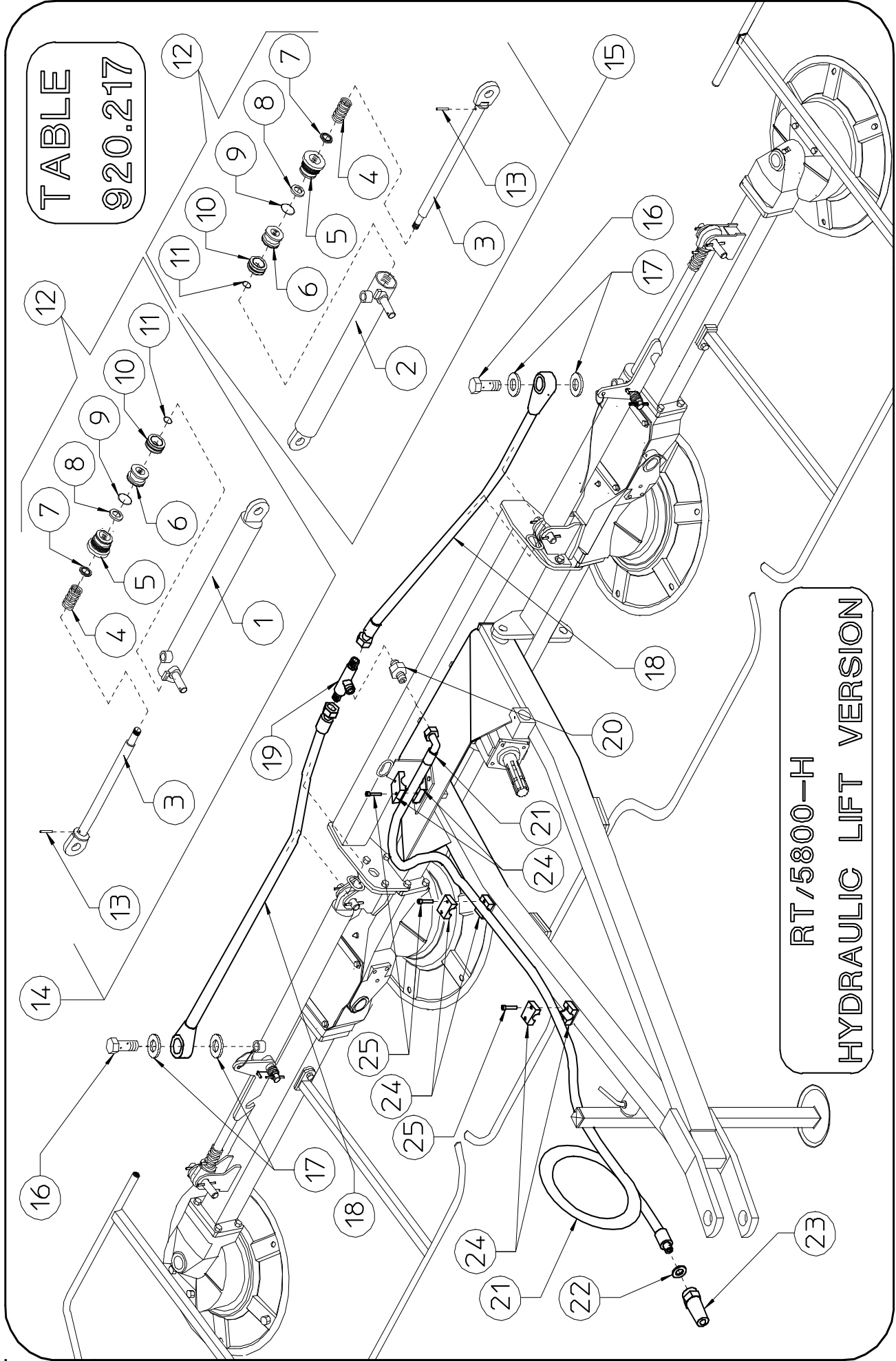

TABLE 920.216

## RT/5800-H - TABLE PART NO 920.216

ITEM	Q.ty	PART NO	DESCRIPTION	NOTE
1	1	220.796	DRAWBAR	
2	1	220.837	CENTER GUARD	
3	1	220.838	RH LATERAL GUARD	
4	1	220.839	LH LATERAL GUARD	
5	1	200.946	STAND	
6	1	200.959	PIN	
7	1	220.790	PIN	
8	1	200.438	HANDLE	
9	1	220.807	PIN	
10	1	200.766	TIE ROD	
11	1	220.808	FORK	
12	1	220.809	PIN	
13	1	600.817	PLUG	
14	1	600.019	PIN	
15	6	600.854	PLUG	
16	5	600.673	SPRING PIN (ø5x40)	
17	1	600.580	SPRING PIN (ø6x26)	
18	3	600.124	GREASE NIPPLE (M6)	
19	2	200.273	SHIM (ø30,3/39,8x1)	
20	8	600.634	SPRING WASHER (ø13-ZN)	
21	4	600.770	SCREW (M12x20 5739-ZN)	
22	6	600.441	SCREW (M12x25 5739-ZN)	
23	1	210.009	ROPE	
24	1	220.822	RH CYLINDER	
25	1	220.823	LH CYLINDER	
26	1	210.098	RH COUPLER	
27	1	210.099	LH COUPLER	
28	1	210.093	RH SPRING	
29	1	210.094	LH SPRING	
30	2	220.825	HITCH	
31	1	220.826	SUPPORT	
32	2	600.018	SPRING WASHER (ø13-ZN)	
33	2	210.103	PIN	
34	2	220.828	PIN	
35	10	600.538	SPRING PIN (ø6x35)	
36	2	600.773	SPRING PIN (ø6x30)	
37	6	600.089	WASHER (ø13-ZN)	
38	4	600.616	SCREW (M12x35 5739-ZN)	
39	4	600.077	NUT (M12 DIN 980)	
40	2	620.278	SCREW (M6x16 5739-ZN)	
41	2	600.472	NUT (M6 DIN 980)	

**TABLE  
920.217**



RT/5800-H - TABLE PART NO 920.217				
ITEM	Q.ty	PART NO	DESCRIPTION	NOTE
1	1	220.829	CYLINDER BARREL, RH	
2	1	220.830	CYLINDER BARREL, LH	
3	2	220.831	ROD	
4	2	200.947	SPRING	
5	2	210.288	CYLINDER HEAD	
6	2	210.289	PISTON	
7	2	610.025	GASKET	
8	2	610.027	GASKET	
9	2	610.026	GASKET	
10	2	610.028	GASKET	
11	2	610.029	GASKET	
12	2	600.895	SET OF GASKET	
13	2	600.106	SPRING PIN (ø3,5x18)	
14	1	220.822	RH CYLINDER, COMPLETE	
15	1	220.823	LH CYLINDER, COMPLETE	
16	2	600.820	FITTING (3/8")	
17	4	600.819	COPPER WASHER (ø1/4")	
18	2	620.286	HOSE (1/4")	
19	1	600.880	"T" ADAPTOR (1/4")	
20	1	600.883	NIPPLE (1/4"-3/8")	
21	1	620.240	HOSE (3/8")	
22	1	600.269	COPPER WASHER (ø1/2")	
23	1	600.273	QUICK COUPLER (1/2")	
24	6	610.035	HALF HOSE COLLAR	
25	6	610.037	SCREW (M6x25 5931-ZN)	

RT/5800-H

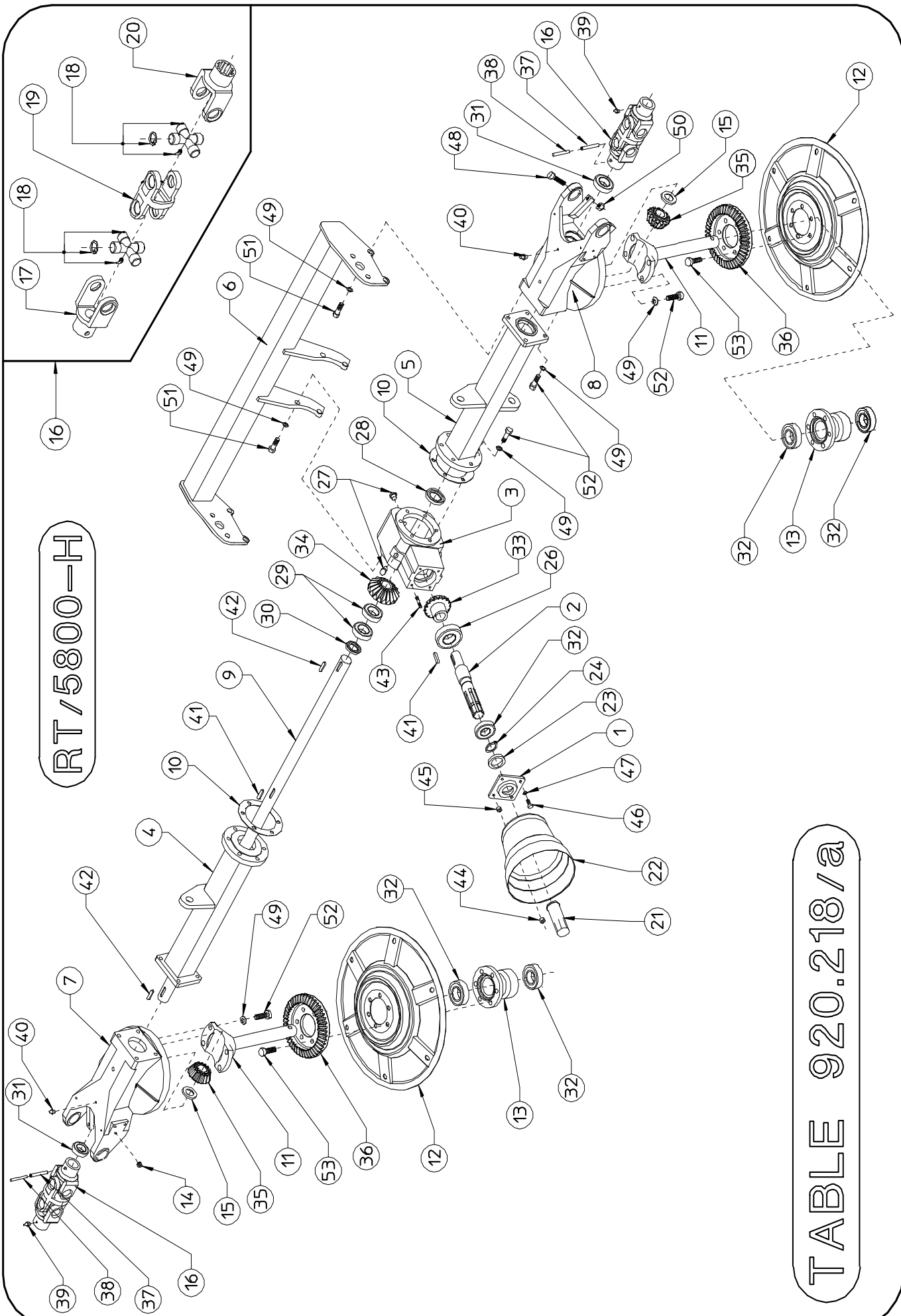

TABLE 920.218/a

## RT/5800-H - TABLE PART NO 920.218/a

ITEM	Q.ty	PART NO	DESCRIPTION	NOTE
1	1	200.395	GEARBOX CAP	
2	1	220.396	SHAFT	
3	1	230.225	GEARBOX	
4	1	220.791	RH CENTER AXLE	
5	1	220.792	LH CENTER AXLE	
6	1	220.795	REINFORCEMENT	
7	1	220.652	RH FORK SUPPORT	
8	1	220.653	LH FORK SUPPORT	
9	1	220.788	DRIVE SHAFT	
10	2	200.405	GASKET	
11	2	200.471	PIN	
12	2	220.834	TINE DISC	
13	2	220.836	HUB	
14	6	600.896	PLUG	
15	2	200.851	SHIM	
16	2	200.857	JOINT, COMPLETE	
17	2	600.813	FORK	
18	4	600.814	CROSS, COMPLETE	
19	2	600.815	CENTER JOINT	
20	2	600.816	SPLINED FORK	
21	1	600.172	SHAFT GUARD	
22	1	600.681	HOOD	
23	1	600.555	OIL RETAINER (ø35/52x10)	
24	1	600.333	SNAP RING (E35-7435)	
26	1	600.827	BEARING (6209 2RS)	
27	2	600.560	PLUG (3/8")	
28	1	600.561	OIL RETAINER (ø30/62x10)	
29	2	600.579	BEARING (6206)	
30	1	600.582	OIL RETAINER (ø30/56x10)	
31	2	600.609	BEARING (6206 2RS)	
32	5	600.608	BEARING (6207 2RS)	
33	1	200.397	PINION	
34	1	200.400	CROWN	
35	2	200.420	PINION	
36	2	220.833	CROWN	
37	2	600.541	SPRING PIN (ø10x55-6873)	
38	2	600.562	SPRING PIN (ø6x55-6873)	
39	2	600.124	GREASE NIPPLE (M6)	
40	2	600.247	GREASE NIPPLE (M10)	
41	2	600.556	FLAT KEY (B8x7x40-6604)	
42	2	600.559	FLAT KEY (B8x7x30-6604)	
43	2	600.558	BOLT (M8x30-5911)	
44	2	600.037	NUT (M8-5588)	
45	2	600.552	NUT (M8-5587)	
46	2	600.222	SCREW (M8x20-5739)	
47	2	600.228	SPRING WASHER (ø8,4)	
48	4	600.153	SCREW (M12x45-5739)	
49	28	600.049	SPRING WASHER (ø13)	
50	4	600.077	NUT (M12 DIN 980)	
51	8	600.687	SCREW (M12x45-5737)	
52	20	600.615	SCREW (M12x35-5739)	
53	12	600.004	SCREW (M12x30-5739)	



RT/5800-H

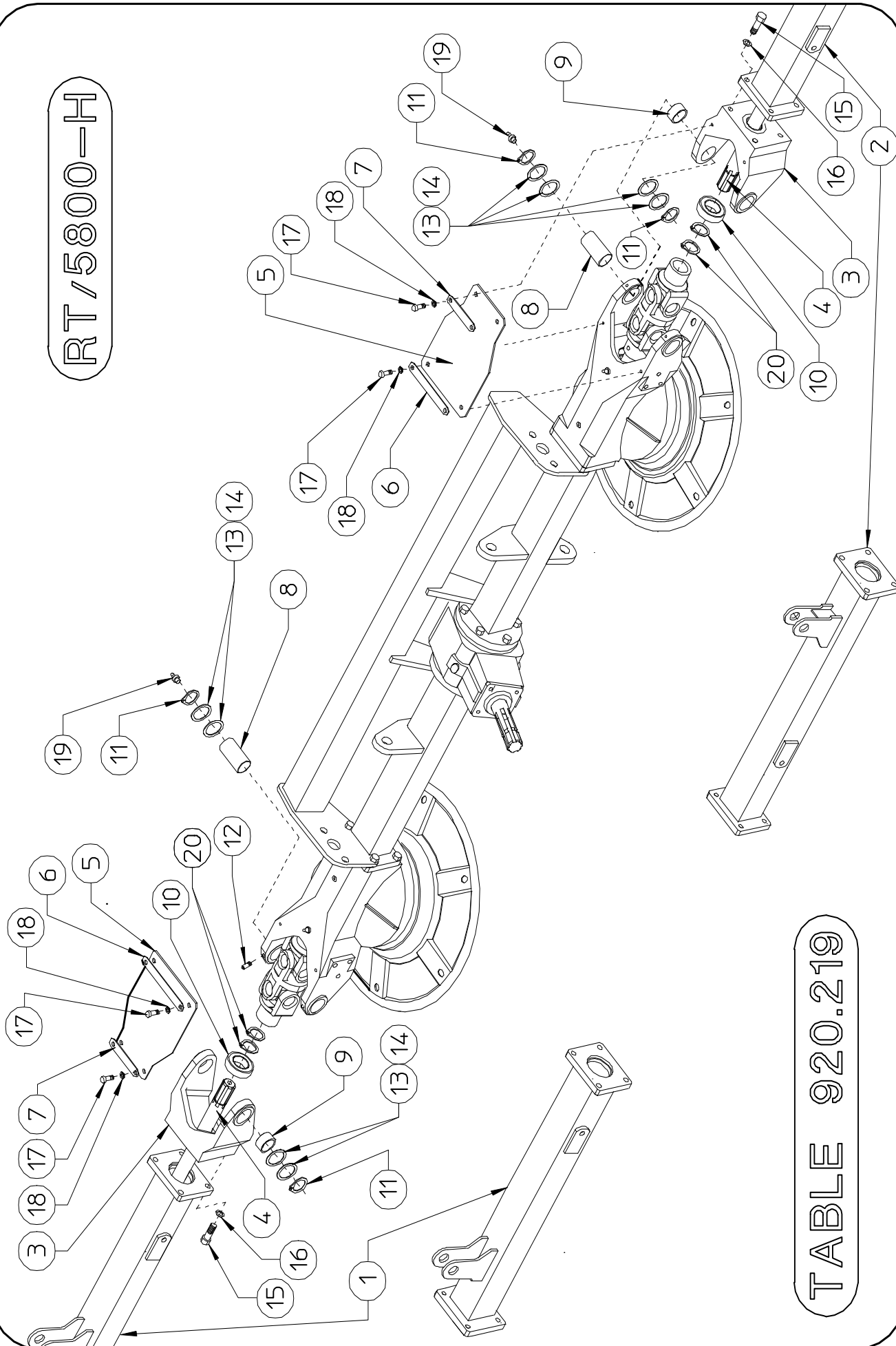
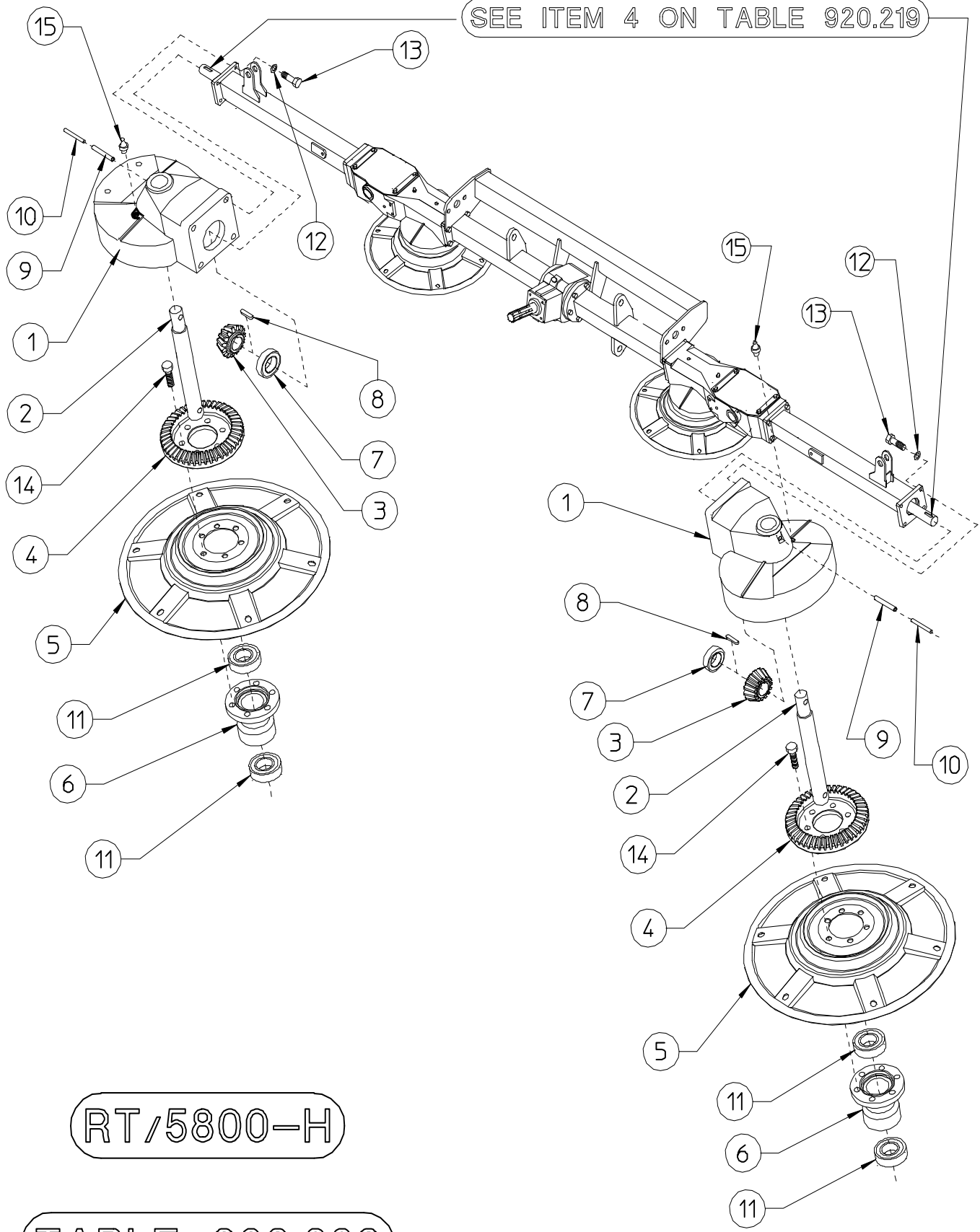

TABLE 920.219

RT/5800-H -TABLE PART NO 920.219				
ITEM	Q.ty	PART NO	DESCRIPTION	NOTE
1	1	220.793	RH LATERAL AXLE	
2	1	220.794	LH LATERAL AXLE	
3	2	220.651	FORK	
4	2	220.789	LATERAL SHAFT	
5	2	220.810	GUARD	
6	2	220.811	PLATE	
7	2	220.812	PLATE	
8	4	200.850	PIN	
9	4	600.808	BUSH (ø30/34x20)	
10	2	600.609	BEARING (6206 2RS)	
11	8	600.611	SNAP RING (E30-7435)	
12	4	600.809	BOLT (M8x12-5927)	
13	4	200.272	SHIM (ø30,3/39,8x0,5)	
14	4	200.273	SHIM (ø30,3/39,8x1)	
15	8	600.615	SCREW (M12x35-5739)	
16	8	600.049	SPRING WASHER (ø13)	
17	8	600.061	SCREW (M8x16-5739 ZN)	
18	8	600.115	WASHER (ø8,4 ZN)	
19	4	600.124	GREASE NIPPLE (M6)	
20	4	620.353	SNAP RING (E29-7435)	

SEE ITEM 4 ON TABLE 920.219



RT/5800-H

TABLE 920.220

RT/5800-H -TABLE PART NO 920.220				
ITEM	Q.ty	PART NO	DESCRIPTION	NOTE
1	2	220.637	GEAR BOX	
2	2	200.407	PIN	
3	2	200.420	PINION	
4	2	220.833	CROWN	
5	2	220.834	TINE DISC	
6	2	220.836	HUB	
7	2	600.609	BEARING (6206 2RS)	
8	2	600.559	FLAT KEY (B8x7x30-6604)	
9	2	600.541	SPRING PIN (ø10x55-6873)	
10	2	600.562	SPRING PIN (ø6x55-6873)	
11	4	600.608	BEARING (6207 2RS)	
12	8	600.049	SPRING WASHER (ø13)	
13	8	600.615	SCREW (M12x35-5739)	
14	12	600.004	SCREW (M12x30-5739)	
15	2	600.247	GREASE NIPPLES (M10)	

TABLE 920.221

RT/5800-H

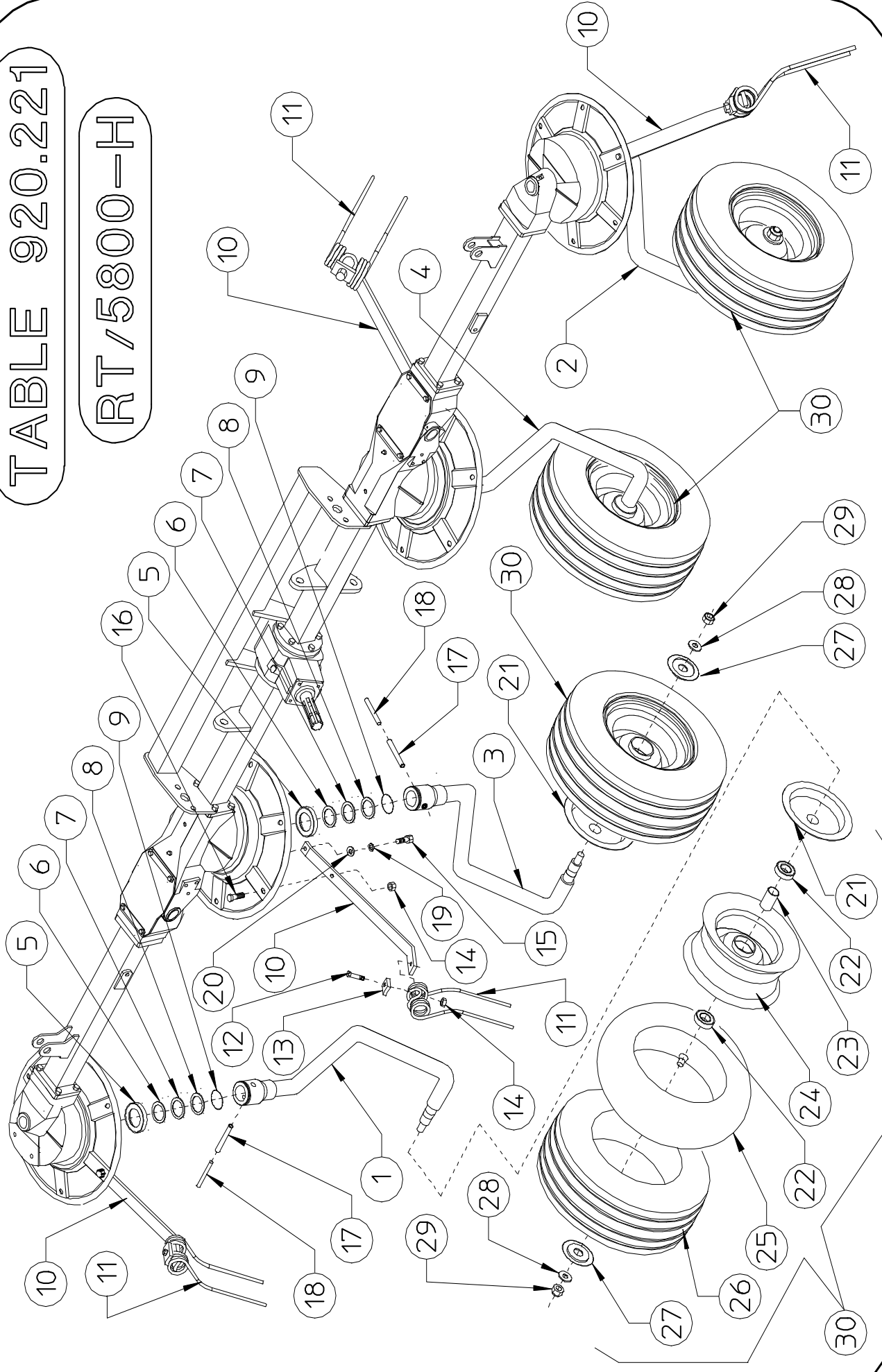

RT/5800-H -TABLE PART NO 920.221				
ITEM	Q.ty	PART NO	DESCRIPTION	NOTE
1	1	210.590	RH LATERAL SUPPORT	
2	1	210.591	LH LATERAL SUPPORT	
3	1	210.592	RH CENTER SUPPORT	
4	1	210.593	LH CENTER SUPPORT	
5	4	220.970	SPACER	
6	4*	200.419	SHIM (ø35,2/51,8x1)	*Q.ty as required
7	4*	200.274	SHIM (ø35,2/48x0,5)	*Q.ty as required
8	4*	200.490	SHIM (ø35,2/51,8x0,3)	*Q.ty as required
9	4	600.568	GASKET (OR 47,63x3,53)	
10	24	220.835	ARM	
11	24	210.574	TINE	
12	24	600.688	SCREW (M12x45-5737 ZN)	
13	24	200.402	PLATE	
14	48	600.077	NUT (M12-DIN 980)	
15	24	610.962	SCREW (M12x30-5739 ZN)	
16	24	600.616	SCREW (M12x35-5739 ZN)	
17	4	600.541	SPRING PIN (ø10x55-6873)	
18	4	600.562	SPRING PIN (ø6x55-6873)	
19	24	600.018	SPRING WASHER (ø13 ZN)	
20	24	220.864	WASHER (ø12,3/28,5x3)	
21	4	210.596	DUST COVER, INNER	
22	8	600.602	BEARING (6205 2RS)	
23	4	200.415	SPACER	
24	4	610.273	RIM	
25	4	610.274	TUBE	
26	4	610.275	TIRE	
27	4	200.416	DUST COVER, OUTER	
28	4	600.031	WASHER (ø17 ZN)	
29	4	600.080	NUT (M16-DIN 980)	
30	4	610.272	TIRE ASSY (16x6,50-8 6PLY)	

**CARDAN SHAFT B3 150E A60792 + LW4**  
**PART NO. 620.356**  
**RT/5800-H PULL TYPE**

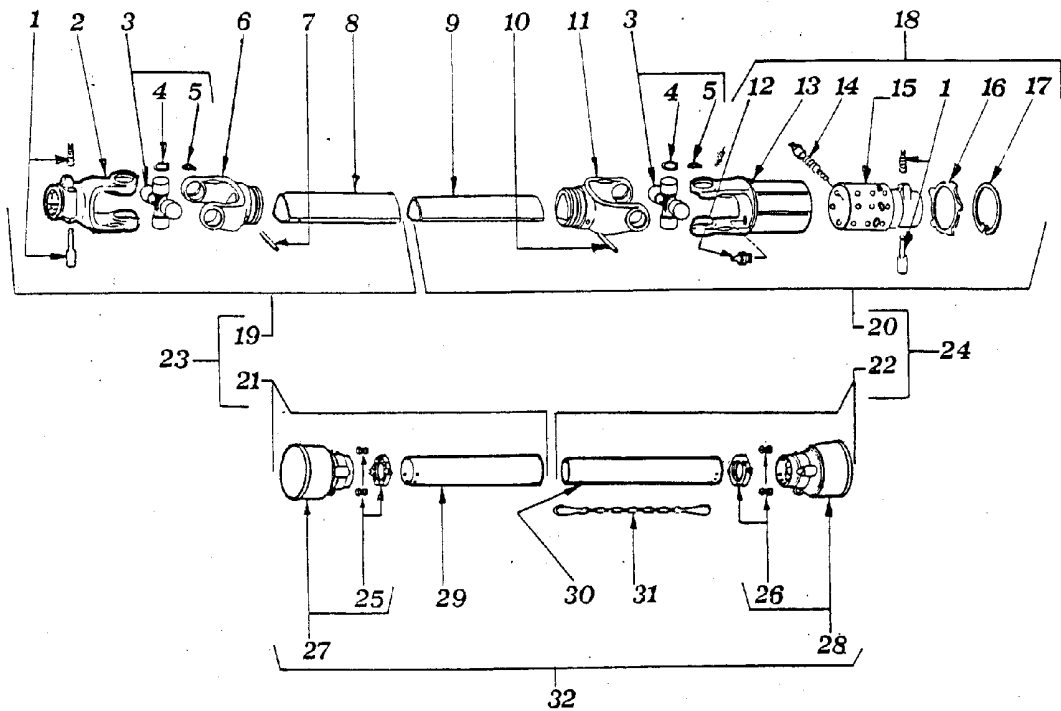

ITEM	PART NO	Q.ty	DESCRIPTION	NOTE
1	610.057	2	COMPLETE PUSH BUTTON	
2	610.234	1	YOKE	
3	610.235	2	CROSS JOURNAL ASS.	
4	610.205	8	CIRCLIP	
5	610.206	2	GREASE NIPPLE	
6	610.236	1	OUTER TUBE YOKE	
7	610.208	1	FLEXIBLE PIN	
8	610.209	1	CM 100 CARDAN TUBE (1 mt)	
9	610.210	1	CM.100 CARDAN TUBE (1 mt)	
10	610.211	1	FLEXIBLE PIN	
11	610.238	1	INNER TUBE YOKE	
12	610.216	1	GREASE NIPPLE	
13	620.631	1	OUTER CASING WITH YOKE	
14	610.218	32	RATCHET TOOTH	
15	620.635	1	HUB	
16	610.220	1	REATING WASHER	
17	610.221	1	CIRCLIP	
18	620.630	1	TORQUE LW4 x 03	
19	620.660	1	HALF SHAFT (WITHOUT GUARD)	
20	620.661	1	HALF SHAFT (WITHOUT GUARD)	
21	620.291	1	HALF SAFETY GUARD	
22	620.292	1	HALF SAFETY GUARD	
23	620.293	1	HALF SHAFT (WITH GUARD)	
24	620.662	1	HALF SHAFT (WITH GUARD)	
25	620.337	1	O. BEARING	
26	620.337	1	I. BEARING	
27	610.080	1	O. BASIC CONE	
28	610.081	1	I. BASIC CONE	
29	620.415	1	SAFETY TUBE	
30	620.416	1	SAFETY TUBE	
31	610.068	1	CHAINE	
32	620.663	1	SAFETY GUARD	





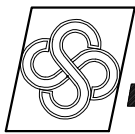

AGRICULTURAL MACHINERY  
**sitrex**<sup>®</sup> Spa .

Zona Industriale-Viale Grecia, 8  
06018 TRESTINA-(Perugia)-ITALY  
Tel. +39.075.8540021-Telefax +39.075.8540523  
e-mail: sitrex@sitrex.it www.sitrex.com

