



FARM EQUIPMENT  
MANUFACTURERS  
ASSOCIATION

NIP 966-159-29-76  
tel. (+48) (85) 654 45 84  
fax (+48) (85) 664 70 41  
e-mail: [samasz@samasz.pl](mailto:samasz@samasz.pl)  
[www.samasz.pl](http://www.samasz.pl)

## OPERATOR'S MANUAL



## REAR DISC MOWER

<b>SAMBA 160</b>	<b>– 5' 3"</b>
<b>SAMBA 200</b>	<b>– 6' 7"</b>
<b>SAMBA 240</b>	<b>– 7' 10"</b>
<b>SAMBA 280</b>	<b>– 9' 2"</b>

Serial no.

**IN0670USA001**  
**2014.01.20**  
**EDITION NO. 1**

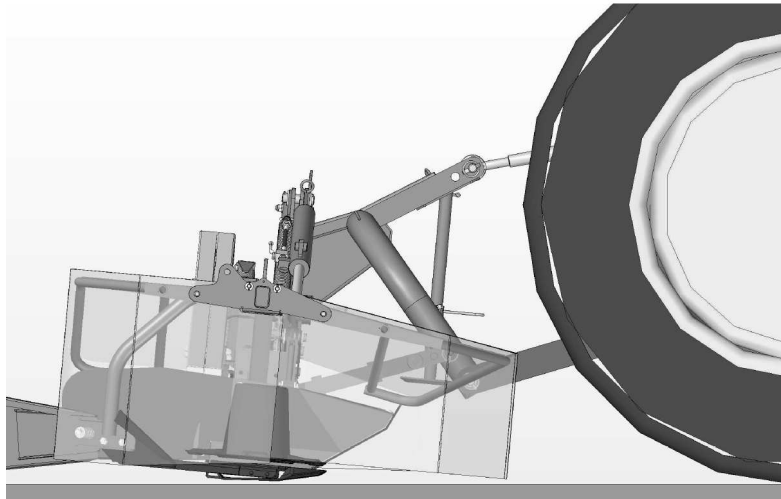

Recommended inclination angle of the cutterbar is  
max. 3° in relation to mowing direction.  
Operate in horizontal position only.



**DO NOT**  
TURN THE DRIVE ON IF THE  
MOWER IS NOT IN ITS WORKING  
POSITION



**DO NOT**  
OPERATE THE MOWER IF  
UNAUTHORIZED PERSONNEL IS  
PRESENT WITHIN 164' OR LESS

**NOTE:**  
Keep this manual for future reference.

<b>Table of contents</b>		<b>page</b>
<b>1. IDENTIFYING THE MACHINE .....</b>		<b>2</b>
<b>2. INTRODUCTION.....</b>		<b>2</b>
<b>3. PROPER AND INTENDED USE .....</b>		<b>3</b>
3.1. Technical data.....		3
3.2. Design and working principle.....		4
3.3. Standard equipment and spare parts .....		4
<b>4. SAFETY PRECAUTIONS.....</b>		<b>6</b>
4.1. General safety rules and regulations.....		6
4.2. Conditions of mounting mower on tractor.....		8
4.3. Transport.....		8
4.3.1. Putting the mower onto another vehicle for transport .....		8
4.4. Working parts .....		10
4.5. PTO shaft.....		10
4.6. Hydraulic assembly .....		10
4.7. Residual risk .....		10
4.8. Safety labels and their meaning.....		12
4.9. Design and operation of safety breakaway device.....		14
<b>5. OPERATION .....</b>		<b>14</b>
5.1. Attaching the mower to the tractor .....		14
5.2. Preparing the mower for transport.....		15
5.3. Preparing the mower for transport on public roads .....		17
5.4. Mounting PTO shaft .....		17
5.5. Moving the mower from transport to working position.....		18
5.6. Preparing the mower for operation .....		19
5.7. Operation .....		19
5.7.1. Basic information on mowing .....		19
5.7.2. Mower blocking.....		20
5.7.3. Driving the mower over windrows when taking turns .....		21
5.8. Unhitching the mower from tractor .....		21
<b>6. MOUNTING AND ADJUSTMENTS .....</b>		<b>22</b>
6.1. Mounting and timing of the knives.....		22
6.2. Replacing the knives.....		23
6.3. Operating service .....		24
6.3.1. Controlling condition of knives and knife holders .....		24
6.3.2. Checking the tension of V-belts on belt gear .....		25
6.3.3. Daily maintenance.....		25
6.3.4. After-season maintenance and storing.....		25
<b>7. LUBRICATION.....</b>		<b>27</b>
7.1. Cutterbar .....		27
7.2. Intersecting axis gear .....		27
<b>8. MALFUNCTIONS AND THEIR REPAIR.....</b>		<b>28</b>
<b>9. DISASSEMBLY AND WITHDRAWAL FROM USE.....</b>		<b>29</b>
9.1. Repair.....		29
9.2. Scrapping .....		29
<b>10. WARRANTY CARD .....</b>		<b>29</b>
<b>11. WARRANTY TERMS .....</b>		<b>30</b>
11.1. Warranty claims procedures .....		30
11.2. Warranty repairs record .....		31

## 1. IDENTIFYING THE MACHINE

Data plate is mounted to the mower's main frame in the place shown below in Fig. 1.

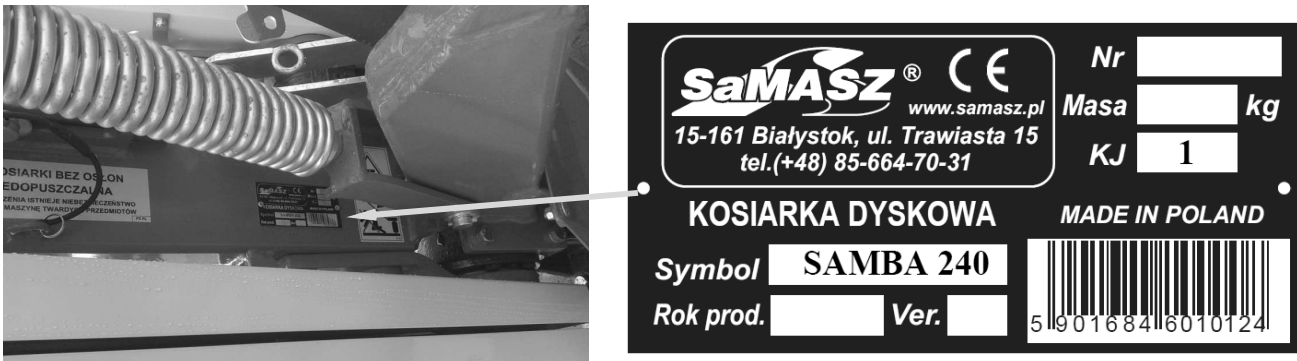

**Fig. 1.** Data plate location

Data plate includes:

- name of the manufacturer,
- mower's serial number,
- mower's type,
- manufacturing date,
- version number,
- weight,
- quality management sign,
- CE mark,
- MADE IN POLAND sign,
- barcode.

## 2. INTRODUCTION

- This operator's manual is essential for safe and proper use of this mower and should be read before anyone operates this mower. It should be kept near the mower for future use. If the mower is used by another operator, it should be in working condition and include this operator's manual and all other basic equipment.
- Operator's manual is attached to every machine in order that the operator can familiarize himself with design, working principles, service and adjustment of the mower. The operator should be familiar with common safety rules and procedures.
- The mower is manufactured according to international safety rules.
- Compliance with the safety precautions in this operator's manual will help to enable safe operation.
- Please contact your dealer if you have any queries relating to the operation and service of the mower.

### 3. PROPER AND INTENDED USE

Light class rear disk mowers SAMBA are designed to operate on smaller farms, and are intended to mow green fodder such as grass and alfalfa on permanent grassland (pastures), on crop fields without rocks, and to form loose rows of cut forage. They do well in mountainous as well as swamp areas, where the machine's and tractor's weight is of great importance. Application of innovative suspension assembly enables adjusting optimal pressure of the cutterbar onto the ground.

Meadows or fields to be mowed should be even, previously prepared by rolling and subjected to other treatment.

**NOTE:** Grass, which has not grown much should be mowed with zero angle inclination.



**WARNING:**

Use of the mower for purposes other than described above is forbidden. Improper use can be dangerous and may lead to voiding of the warranty. Mower should be operated and repaired only by people familiar with its detailed specifications and with all applicable safety rules and regulations and with the relative dangers. Unauthorized modifications to the mower will lead to voiding the warranty.

### 3.0. Technical data

**Tab. 1. Machine specification**

	SAMBA 160	SAMBA 200	SAMBA 240	SAMBA 280
Working width [ft/in]	5' 3"	6' 7"	7' 10"	9' 2"
Number of knives [pcs]	8	10	12	14
Number of disks [pcs]	4	5	6	7
Tractor's PTO rears [rpm]	540			
Tractor power required [HP]	from 20	from 30	from 45	from 60
Working capacity [ha/h]	~ 1.5	~ 2.0	~ 2.5	~ 3.0
Transport length [ft/in]	5' 10"			
Transport width [ft/in]	5' 7"			
Width after aggregation [ft/in]	12' 7/8"	12' 12"	13' 11"	14' 9"
Transport height [ft/in]	7' 1/4"	8' 3"	9' 6"	10' 9"
Weight [kg / lbs]	410 / 904	445 / 981	490 / 1,080	505 / 1,113
Cutting speed of the knife [m/s]	83			
Disc rotation speed [rpm]	3115			
3-point linkage category	II	II	II	II
Noise level $L_{pA}$	77.0 ± 3.0 dB			
$L_{Amax}$	76.0 ± 3.0 dB			
$L_{Cpeak}$	98.5 ± 3.0 dB			

$L_{pA}$  – noise level related to 8 hour working time. Averaged in time acoustic pressure level corrected by frequency characteristic A.

$L_{Amax}$  – maximum value corrected by frequency characteristic A of acoustic pressure level.

$L_{Cpeak}$  – peak level of acoustic pressure corrected by frequency characteristic C.

### 3.1. Design and working principle

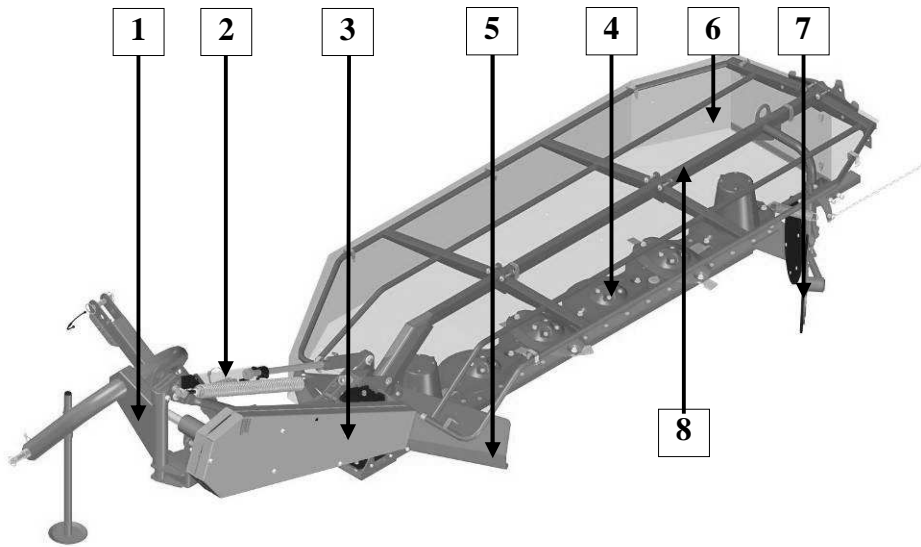

**Fig. 2.** Parts of SaMASZ rear disc mower SAMBA

- |                                  |                                    |
|----------------------------------|------------------------------------|
| 1 – Linkage                      | 5 – Swath guide                    |
| 2 – Cylinder with support spring | 6 – Safety guard                   |
| 3 – Belt gear                    | 7 – Disk type swath guide (option) |
| 4 – Cutterbar                    | 8 – 3-point linkage frame          |

Linkage (1) enables attaching the mower to tractor's 3-point linkage. Drive from tractor's PTO is transmitted by belt gear (3) onto *EcoCUT* cutterbar (4). Hydraulic lifting cylinder (2) fed from the external tractor's hydraulics is used to adjust the mower to working position. On 3-point linkage frame (8) the spring-suspended cutterbar is set. The frame has also swath guides (5), which are delivered as standard, optional disk type guides (7) and protective guard (6).

### 3.2. Standard equipment and spare parts

**The mowers are sold with the following standard equipment:**

- warranty card,
- operator's manual with spare part list,
- cutting knives: additional set,
- PTO shaft with overrunning clutch,
- spray paint (150 ml).

**Optional extra equipment:**

- warning plates with combined lights and reflectors,
- warning triangle,
- double rubber guide.

**Tab. 2.** Recommended PTO shaft

Mower	Power	Length	Torque	Symbol	Clutch	Manufacturer	Remarks
	HP	ft. in	Nm				
SAMBA 160 SAMBA 200 SAMBA 240 SAMBA 280	35	2' 2"-2' 11"	460	7G3N066CE007096MA	Right-hand overrunning	BONDIOLI& PAVESI	

PTO shaft side, without the clutch  
– to be mounted facing the tractor

PTO shaft side, with right  
overrunning clutch – to be  
mounted facing the mower

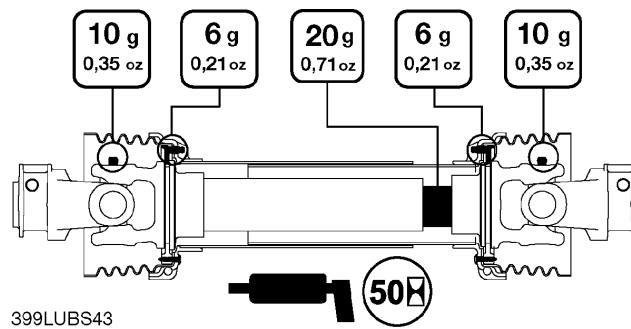

**Fig. 3.** PTO shaft lubrication points. Mounting directions

**NOTE:**

Lubricate the PTO shaft with high quality multi-purpose grease every 50 shaft operating hours (**Fig. 3**). If access holes are accessible, lubricate fittings through access holes.

PTO shafts of other brands with equivalent parameters could be used after first obtaining SaMASZ permission.

**NOTE:**

Optional equipment should be ordered separately.

The mower is equipped with optional equipment such as holders and brackets used to mount warning lights and plates. Combined lights and reflectors are mounted on warning plates.

## 4. SAFETY PRECAUTIONS

 **WARNING** The following precautions are for your safety. They must be read carefully and followed by every person who operates or maintains the machine. Failure to follow these safety precautions could result in serious injury or death to the operator, maintenance person or bystanders and property damage to the machine and surrounding property.

### Safety Signal Words

This manual and the safety labels attached to this equipment utilize signal words that signify safety hazards with different levels of severity. Below are the words used and the definitions for these words:

- **DANGER** indicates a hazardous situation which, if not avoided, will result in death or serious injury
- **WARNING** indicates a hazardous situation which, if not avoided, could result in death or serious injury
- **CAUTION** indicates a hazardous situation which, if not avoided, could result in minor or moderate injury
- **NOTICE** is used to address practices not related to physical injury

#### 4.0. General safety rules and regulations



The following descriptions are for your safety: They must therefore be read carefully and applied every time you use the machine.

- The machine has been designed for use by one single operator.
- When using, servicing, repairing, moving or storing the machine, the operator must wear safety footwear, safety gloves plus ear protection and dusk mask if necessary.
- During use, the machine may give rise to dust, especially if the soil is dry. You are advised to use a tractor with a cab fitted with filters in the ventilation system. Failing this, wear a dust mask with filter to protect your respiratory tract
- Front axis of the tractor should be weighted to keep the balance. If need be, use front wheel weights.
- In order to keep steering conditions, impact on front axis should be at least 20% of the complete tractor.
- Be extremely careful whenever using hydraulic lift lever or buttons. Any operation with hydraulic lift lever should be done from operator's seat; DO NOT move the lever from outside of a tractor.
- In case of tractors equipped with EHR, operating with hydraulic lift is done by the buttons mounted outside the tractor's cabin. When operating be extremely careful.
- When switching from mowing to transport position, remove the entire PTO shaft or at least one end of the shaft from the tractor's PTO so it cannot turn.
- When attaching the mower to a tractor, the operator should wear protective gloves.
- DO NOT operate the mower unless all safety guards are in place and operational. In addition, any damaged protective aprons should be replaced with a new one
- Start mowing only when tractor's PTO reaches its normal 540 rpm. DO NOT exceed 600 PTO rpm.
- No person (except operator) should stand within danger area which is a minimum of 170' from any operating part, especially when operating near roads and in areas with stones and other debris. Be certain that children and animals are at a safe distance away from the machine.



**IMPORTANT:** Maintenance and adjustment should ONLY be done after the following has occurred:

1. tractor's engine has been stopped and ignition key has been taken out,
  2. all rotating parts have come to complete standstill (NOTE: cutting knives will rotate for several minutes after engine is turned off),
  3. the cutterbar is on the ground, and
- ❑ Never tamper with or remove safety devices on the machine or make them inoperable.
  - ❑ Before starting work and periodically thereafter, replace any damaged, missing and/or worn knives and knife holders.
  - ❑ When driving on public roads always comply with local traffic regulations, especially those concerning warning lights.
  - ❑ When the mower is lifted for repair on 3-point linkage, it should be secured against falling by mechanical support or by chain.
  - ❑ The bolts and other fasteners have to be periodically checked and, if necessary, tightened or replaced. DO NOT work with damaged or worn fasteners.
  - ❑ Never lift the mower on tractor linkage when the drive is operating and the cutting discs are rotating.
  - ❑ When operating the mower, the tractor should always be equipped with operator protection that is required by laws and regulations.
  - ❑ Never start the mower when the mower blades are off the ground.
  - ❑ Before you start the tractor make sure that all drives are turned off and the levers that turn the hydraulics are in neutral position.
  - ❑ Never leave tractor's engine running without supervision. Before you leave the tractor, turn off the engine and remove the key from tractor's ignition.
  - ❑ DO NOT operate the mower when driving the tractor backwards.
  - ❑ Permissible inclination of the mower on a slope when working and during transport is 8°. Exceeding this incline can result in mower tipover.
  - ❑ Never stand between tractor and mower unless tractor and mower are secured against moving by the tractor's brake.
  - ❑ If any maintenance must be done under an elevated mower, it must be blocked or otherwise secured against falling.
  - ❑ When the parts of the mower need replacement, use only original spare parts as described in the spare parts list. Pay particular attention to PTO shaft's guards and mower's and tractor's spline shaft guards.

Hydraulic hoses are potentially very dangerous. Do the following to minimize any hazards:

1. Hydraulic hoses should be periodically checked and if any damage to the hoses have occurred or if they have been used more than 5 years, replace with new ones.
  2. Never use scotch tape to repair hydraulic hoses.
  3. When connecting hydraulic hoses to tractor's hydraulic connectors, make sure that the tractor's or mower's hydraulic system is not under pressure.
- ❑ The mower should be stored under a roof and in a way as to not be hazardous bot people or animals.
  - ❑ In the event of an accident involving this mower in a field or on a road, follow all applicable first aid procedures and contact SaMASZ technical service.
  - ❑ Mower should be kept clean, so as to avoid danger of fire.

#### 4.1. Conditions of mounting mower on the tractor

- ❑ Prior to the mounting operation, be sure that the tractor and mower hitches are compatible and that the tractor's hitch load is adequate for the machine which is to be mounted or attached.
- ❑ Prior to mounting the machine, examine the technical condition of the mower's hitch assembly and tractor's 3-point linkage.
- ❑ Use only genuine cotter pins to mount the mower on a tractor.

#### 4.2. Transport

The lifting, handling and transporting operations can be very dangerous unless they are carried out with the utmost caution. Have all persons not involved in the actual work move away from the area and limit the zone where the operations are to be carried out. Also make sure that the area in which the operations take place is clear and that there is a sufficient escape route, i.e. a free, safe zone to which the operators can quickly move if the load should fall.

The safety hooks and ropes used to lift the machine must be of an adequate carrying capacity.

To minimize the risk of serious injury or death, do the following:

- ❑ When the machine is converted from the transport position to the work position and vice versa, you could be pinched or crushed by some of its parts. Take extra care when carrying out these maneuvers and have all persons keep well clear of the danger zone.
- ❑ Do not change position of the mower until there are no people or animals around (pay particular attention to children).
- ❑ While transporting the mower, put a warning plate with combined lights and reflectors and warning triangle on the mower.
- ❑ During transport, always put the mower in its proper and safe transport position. See section 5.2.
- ❑ Before putting the mower in transport position, make sure that the tractor's PTO is turned off and all rotating parts have come to a complete stop.
- ❑ Do not drive over 25 km/h (15 mph). Drive slower if road conditions are poor, especially on irregular surfaces or steep slopes.
- ❑ The behavior of the tractor on the road, such as its turning and braking capacities, are affected by the implements mounted.
- ❑ When driving on the road after work, check to make sure that the tires and soil working tools are clean to prevent the road surface from becoming dirty.
- ❑ Make sure that the machine is not damaged during transport.

##### 4.2.1. Loading the mower onto another vehicle for transport

The driver and the carrier are responsible for the mower's transport safety. Equipment and parts must be secured during transport. To put the mower onto another vehicle in a safe way, please obey the following rules:

- ❑ Transport should be done by qualified and specifically trained personnel,
- ❑ Grab the mower by any lifting devices only in places indicated by hook sign (Fig. 4),

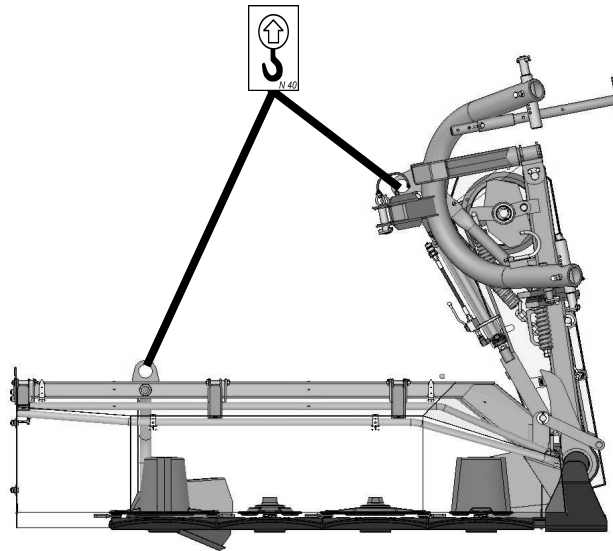

**Fig. 4.** Transport holders

- ❑ For mower lifting, use only lifting devices with hoisting capacity larger than mower's weight shown in data plate. This also applies to ropes and chains used for lifting,
- ❑ Do not lift if transport belts, belt suspensions, ropes are damaged. Whenever damage to these parts occurs, replace with new ones,
- ❑ When mounting slings, chains, handles etc., always set the machine's center of gravity properly,
- ❑ To safely support the machine, use ropes of adequate length so that the angle between them is no greater than  $120^\circ$ , and the angle between the strand and the vertical is no greater than  $60^\circ$ ,
- ❑ Lift the machine with the utmost caution and move it slowly,
- ❑ No one should be within the range of action of the lifting equipment when any transporting operations are being carried out,
- ❑ Collapsible parts should be blocked in transport position,
- ❑ When the mower is on the vehicle's trailer, the machine should be secured against moving.

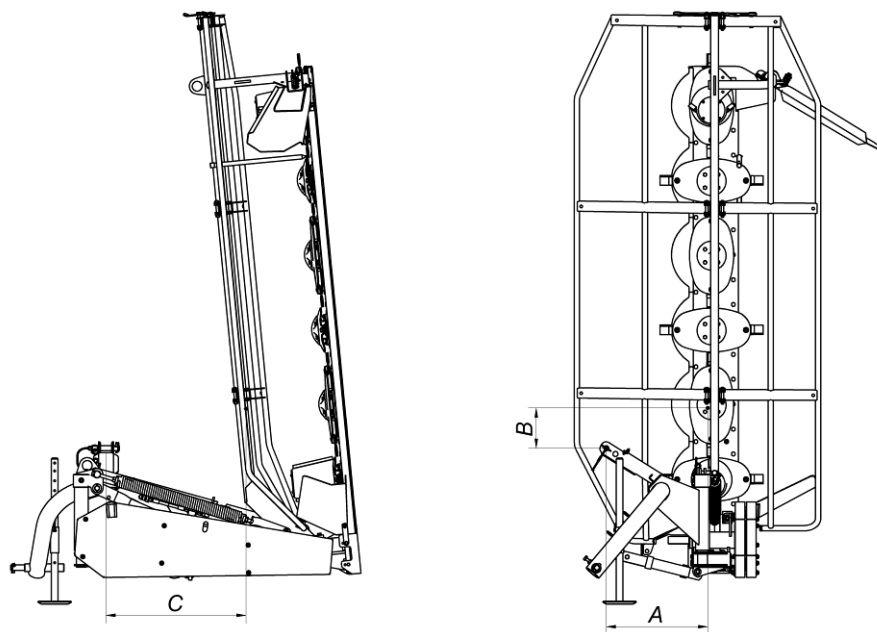

**Fig. 5.** Location of center of gravity on Samba mowers

**Tab. 3.** Location of center of gravity

Dimension [ft. in]	Mower type			
	Samba 160	Samba 200	Samba 240	Samba 280
<b>A</b>	1' 8"	1' 8"	1' 8"	1' 8"
<b>B</b>	-2 ½"	3"	8"	1' 2"
<b>C</b>	2' 2"	2' 4"	2' 4"	2' 6"

### 4.3. Working parts

- ❑ Before operating the mower, check knife's and knife holder's condition.
- ❑ Worn or damaged knives or knife holders should be immediately replaced with new ones.

### 4.4. PTO shaft

- ❑ Before operating, read bar manufacturer's manual placed on the bar. Follow all safety precautions in that manual.
- ❑ Use only PTO shafts recommended by mower's manufacturer with guards in good condition.
- ❑ In order to operate safely, use only undamaged PTO shafts and shields. Damaged PTO shafts and shields must be repaired or replaced with new ones before use.

### 4.5. Hydraulic assembly

- ❑ Hydraulic assembly is under high pressure. Hydraulic oil under pressure may penetrate skin and cause serious injury or death. Skin and eyes should be protected when working around this assembly.
- ❑ In case of injury caused by a liquid under pressure, call a doctor immediately.
- ❑ Hydraulic hoses can be connected to the tractor's hydraulics provided that both the tractor's and the mower's hydraulic assemblies are not under pressure. To remove the pressure from the hoses, start the tractor's hydraulic valves several times with the tractor off.
- ❑ When looking for oil leaks, do so safely. Use a cardboard card. Do not touch any potential leaks until the entire hydraulic assembly has been relieved of pressure.
- ❑ Use only hydraulic oil featuring oil purity class 9 - 10 according to NAS 1638.

#### When using hydraulic hoses:

- ❑ Avoid stretching the hoses when operating.
- ❑ Do not allow hydraulic hoses to get deflected.
- ❑ Do not expose hydraulic hoses to contact with any sharp edges.
- ❑ If damaged or worn, replace the hoses with new ones.
- ❑ Useful life for hydraulic hoses is 5 years from their production date.

### 4.6. Residual risk

Despite the fact that SaMASZ Białystok, the manufacturer of the mower, has taken great care in the design and manufacturing of the mower, certain risks during mower operation and maintenance are unavoidable. A major source of risk that could result in serious injury or death can occur during the performance of these operations.

Major source of risk follows performance of these operations:

- ❑ operation of mower by minors,
- ❑ operation by individuals who have not read the operator's manual and safety labels,
- ❑ operation of mower by persons under influence of alcohol or other substances,
- ❑ not being cautious during transportation and moving mower during operation,
- ❑ transport of persons who are on the machine,
- ❑ presence of persons and animals within the mower operation range,
- ❑ performing servicing and machine adjustments with the engine on.

#### 4.7.1. Danger of machine entanglement

This risk occurs when (1) changing position of a mower, (2) operating near rotating parts, and (3) working without safety guards. During operation, maintenance and adjustment, always wear protective gloves, shoes and clothes without loose parts, belts and so on. Always comply with safety labels placed on the mower

#### 4.7.2. Danger of cutting injury

This risk occurs during replacement of working parts with sharp edges. During any maintenance work, always use safety gloves.

#### 4.7.3. Danger of injury from liquid ejection out of hydraulic system

During connection of hydraulic hoses to hydraulic connectors, be sure that tractor's or mower's hydraulic system is not under pressure. Regularly check hydraulic hoses for leaks.

#### 4.7.4. Forbidden actions

During mower's operation, do not do the following:

- ❑ never unblock the mower, make any regulations or repairs of the mower while it is in motion,
- ❑ never change order of operation and maintenance activities described in operator's manual,
- ❑ never operate the mower when it is not in working order or has damaged safety guards,
- ❑ never get your hands and legs close to rotating parts of the mower,
- ❑ during repair and maintenance of the mower, always comply with descriptions included in operator's manual. Always do these activities when the tractor's drive is off,
- ❑ never operate the mower under influence of alcohol, drugs, or strong medicine that impair your attention,
- ❑ do not wear jewelry or clothes that are too loose or too tight. Too loose clothing or jewelry may be pulled in by the rotating parts of the mower,
- ❑ the mower should not be operated by children or by handicapped people,

When describing residual risk, the mower complies with the state of the art in technology on the date it was manufactured.

#### 4.7.5. Residual risk assessment

Residual risk occurs from not complying with the instructions and safety precautions. Such risk can be minimized by doing the following:

- ❑ thorough familiarizing yourself with operator's manual,
- ❑ allow no persons on the machine when operating,
- ❑ allow no persons within the mower operation range,
- ❑ adjust, maintain and lubricate the machine with the engine off,
- ❑ only skilled persons should perform repairs of the machine,
- ❑ children and strangers must keep away when the machine is operating.



When the risk of exposure to noise cannot be avoided or eliminated by any protective means or organization of work, the employer (farmer) must:

- 1) provide the operator with individual means of noise protection if the noise level in work place exceeds 80 dB.
- 2) provide the operator with individual means of noise protection and supervise the correctness of its usage, if the noise level in work place reaches or exceeds 85 dB.

**4.7. Safety labels and their meaning**

Safety labels are critical to safe use of this mower. They must be read, understood and followed. Also, be sure that:

- All warning decals are clean and legible,
- All lost or damaged decals are replaced by ordering new decals from your dealer or supplier,
- All persons using this mower have read the section of this manual explaining the meanings of these labels,
- All spare part used for repair of the mower should have all safety labels provided by the manufacturer.



N-1

Be extremely careful when PTO shaft is rotating.



N-2

Caution: cutting knives. Approach during operation is forbidden



N-3

Read the operator's manual before putting the mower into operation



N-4

While making repairs the machine must be stopped



N-5

Caution: belt gear, keep particular attention



N-6

Caution: pulling-in parts



N-7

Operating is forbidden when any person is within the danger area of 170'

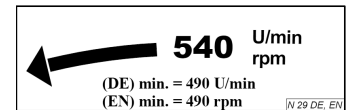

N-29

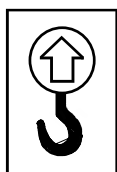

N-40

Signs indicating transport holders



N-49

Never stand near tractor's 3-point linkage while steering tractor's lift



N-50

Do not stay in the swinging area of mower's parts



N-206

Wear protective gloves



N-117

Avoid fluid escaping under pressure. Consult technical manual for service procedures



N-167

Do not go onto safety brackets and guards



N-168

Do not touch the machine before the rotating parts have not come to a complete standstill

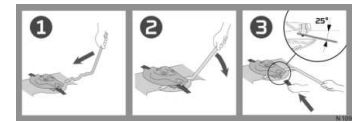

N-109

**CLEAN THE MOWER EACH DAY AFTER WORKING**

Especially between discs and the cutterbar, because grass with mud may damage bearings in the disc module.

N-31

**16 MPa**

N-55



It is forbidden to put the machine into vertical position before the discs reach the standstill and to start the PTO shaft in transport position. It may damage the PTO shaft.

N-63

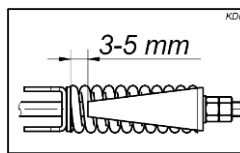

N-155

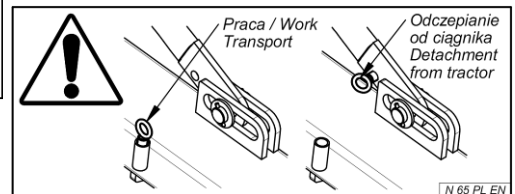

N-65

**DANGER**

OPERATING WHEN ANY PERSON REMAINS IN THE DANGER AREA OF **170 ft**

P-3



N-204

**WORKING WITHOUT GUARDS IS FORBIDDEN**

DANGER OF THE STONES, ETC. BEING THROWN OUT

P-2

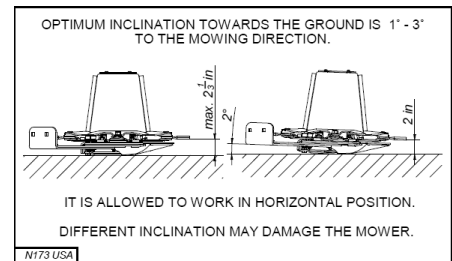

N-173

Use the required Personal Protection Equipment

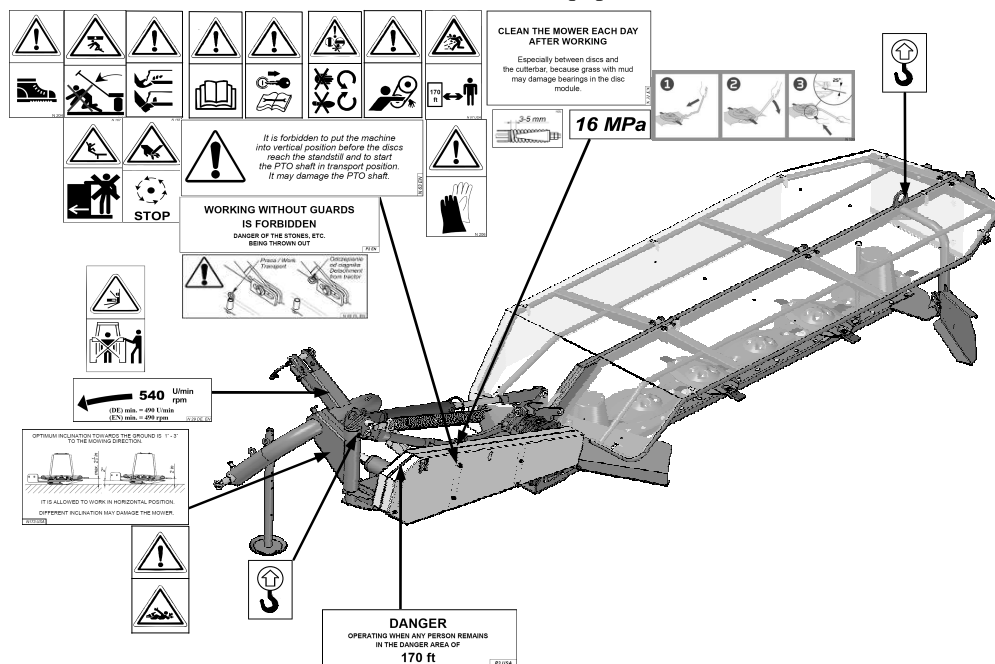

Fig. 6. Warning labels placed on the mower



**CAUTION:**

Any spare part used for repair of the mower should have all warning decals provided by the manufacturer.

**4.8. Design and operation of safety breakaway device**

Hydraulic safety breakaway device protects mower against hitting small obstacles. In the event the mower hits an immovable obstacle, the cutterbar folds back about 20° (Fig. 8). Operator then has enough time to stop the tractor and avoid the mower damage.

The safety breakaway device's spring (Fig. 7) with adjustable deflection enables changing the device's activation time.

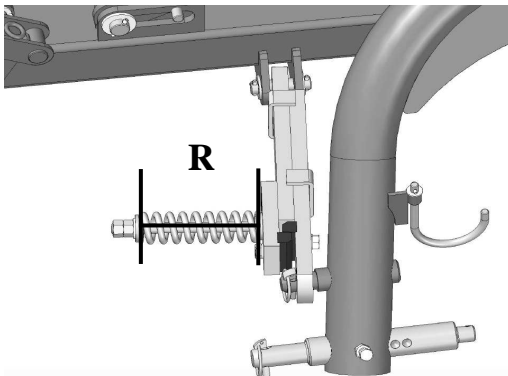

**Fig. 7.** Mower's safety breakaway device

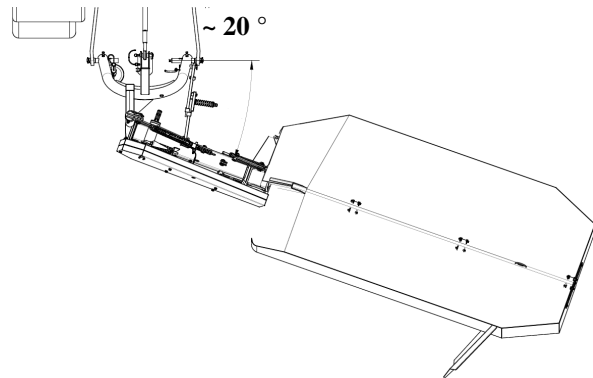

**Fig. 8.** Mower retracting upon use of the breakaway device

Length of pressed safety breakaway device's steel spring (**R** in Fig. 7) should be  $R=5.43''$ ,  $\phi 10$  mm,  $D = 1.5''$ . When the safety breakaway device is loosened frequently, **R** shall be reduced by 0.3–0.6". Bear in mind, that too tight the spring tension may cause the breakaway device to be locked, and therefore machine to be damaged.

**5. OPERATION**

**WARNING:**

Before beginning to use this machine, do the following:

- Read manual, especially safety precautions in section 4.
- Make sure you are familiar with all controls and functions.
- Make sure all safety devices are in place and working. Fix or replace if not working or damaged.
- Replace protective cover if damaged.



**5.0. Attaching the mower to the tractor**

**WARNING:**

- Only hitch and unhitch machine on a flat surface with compact dirt.
- Keep everyone away from area between mower and tractor.
- Be careful near link road zone of tractor's rear power lift. Contains sharp parts.





Mower should be attached to the tractor with use of 3-point linkage as provided in **Fig. 9**. After the mower has been attached, adjust mower's position by means of top **S** and lower links (**W**). The cutterbar should lean towards driving direction. Lower links **W** should be connected to 3-point linkage frame pins **A** (**Fig. 9**). Connect hydraulic hoses to tractor's hydraulic connectors.

After the mower has been attached to tractor, check balance and steerability of tractor-mower set. To do it, weigh the set and after that drive on the scales with only front axis of the tractor (the mower must be in transport position – lifted upwards). If the pressure on the front axis is at least 20% of the whole set's pressure, it means the set is stable. If not, front axis should be balanced.

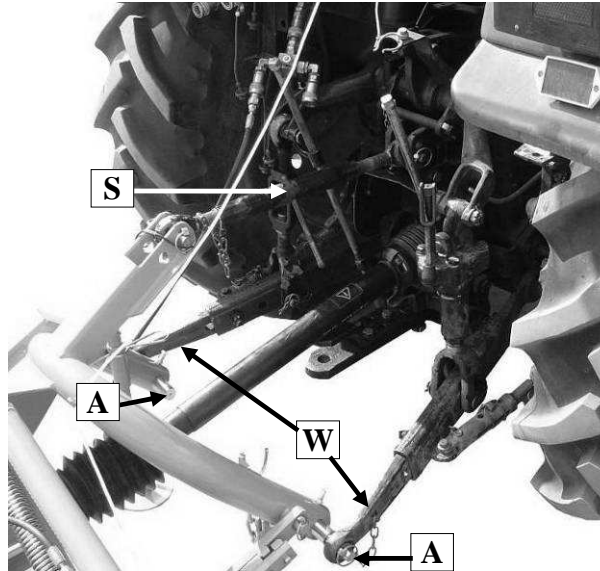

**Fig. 9.** Connecting mower to the tractor

**NOTE:**

Before dismantling the mower from the tractor put safety pin (**1**) into hole (**3**) in the cutterbar to protect the hitch from falling. After the mower has been mounted put the pin in bushing (**2**) (**Fig. 10a**) on central beam.

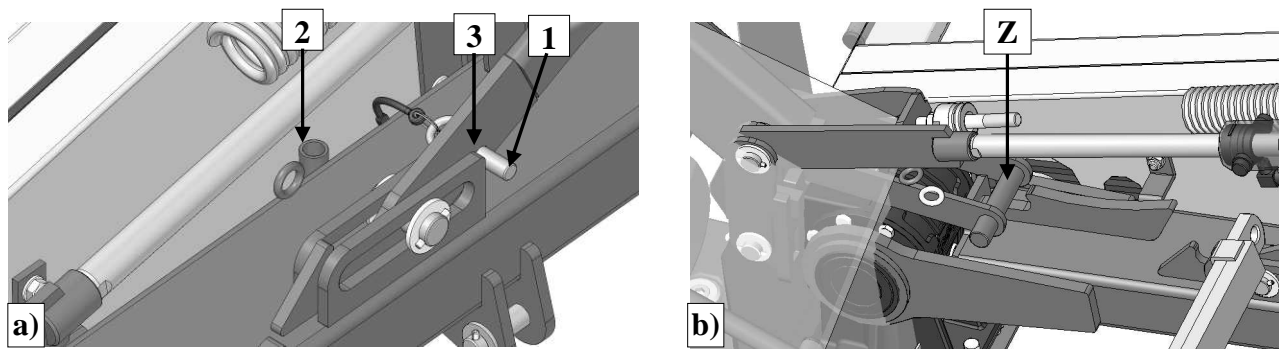
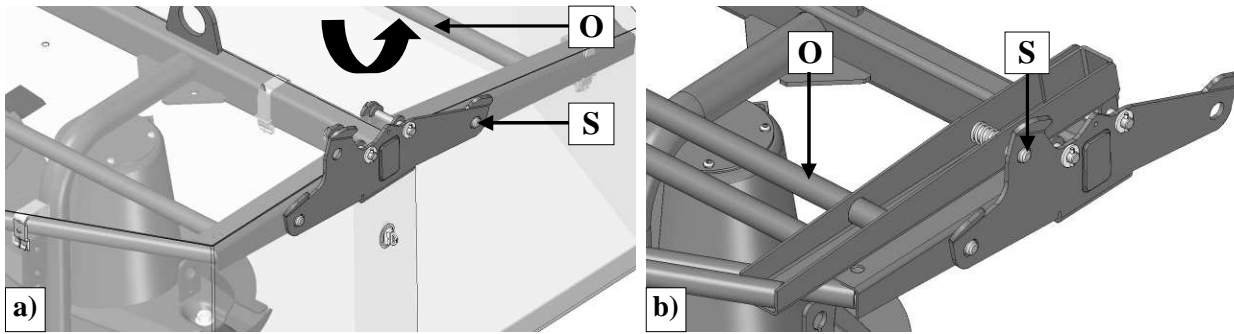

**Fig. 10.** a) 1 – safety pin, 2 – bushing, 3 – hole in cutterbar, b) Z – locking pawl

**5.1. Preparing the mower for transport**

**NOTE:**

Before moving the mower to transport position lift the mower's front guard (**O**) up and secure it with pin (**S**) (**Fig. 11**) on the guard's right side. The guard, if not lifted up and improperly protected, may cause serious damages to the mower's guards or tractor's parts, e.g. rear lights.



**Fig. 11.** Setting front guard for transport

To prepare the mower for transport and to meet safety precautions, please do the following:

- ❑ lift the mower's front guard and secure it with pin,
- ❑ lift the mower with tractor hydraulic lift until the lower lift pins of the mower 3-point linkage frame raise about 1' 8" above the ground (**Fig. 13**),
- ❑ remove safety pin (**1**) and place it in bushing (**2**) (**Fig. 10a**),
- ❑ lift the cutterbar vertically with hydraulic cylinder and lock the locking pawl (**Z**) (**Fig. 10b**),
- ❑ secure the cutterbar against falling by activating the shut-off valve (**Z**) (**Fig. 12b**) placed on the mower's hydraulic cylinder,
- ❑ dismount PTO shaft from tractor,
- ❑ lift support leg and secure it with cotter.



**WARNING:**

During transport, the shut-off valve lever must be closed in (**Z**) position (**Fig. 12b**). This prevents the mower against accidental dismantling if unexpected motion of the tractor and the mower occurs – in worst case, causing potential cracks on hydraulic hose, leading to an accident.

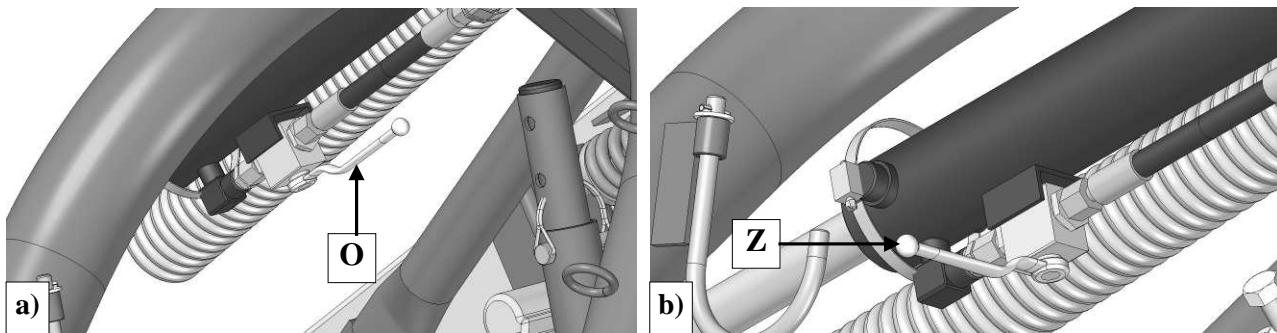

**Fig. 12.** Cylinder valve position: a) open **O** (work), b) closed **Z** (transport)

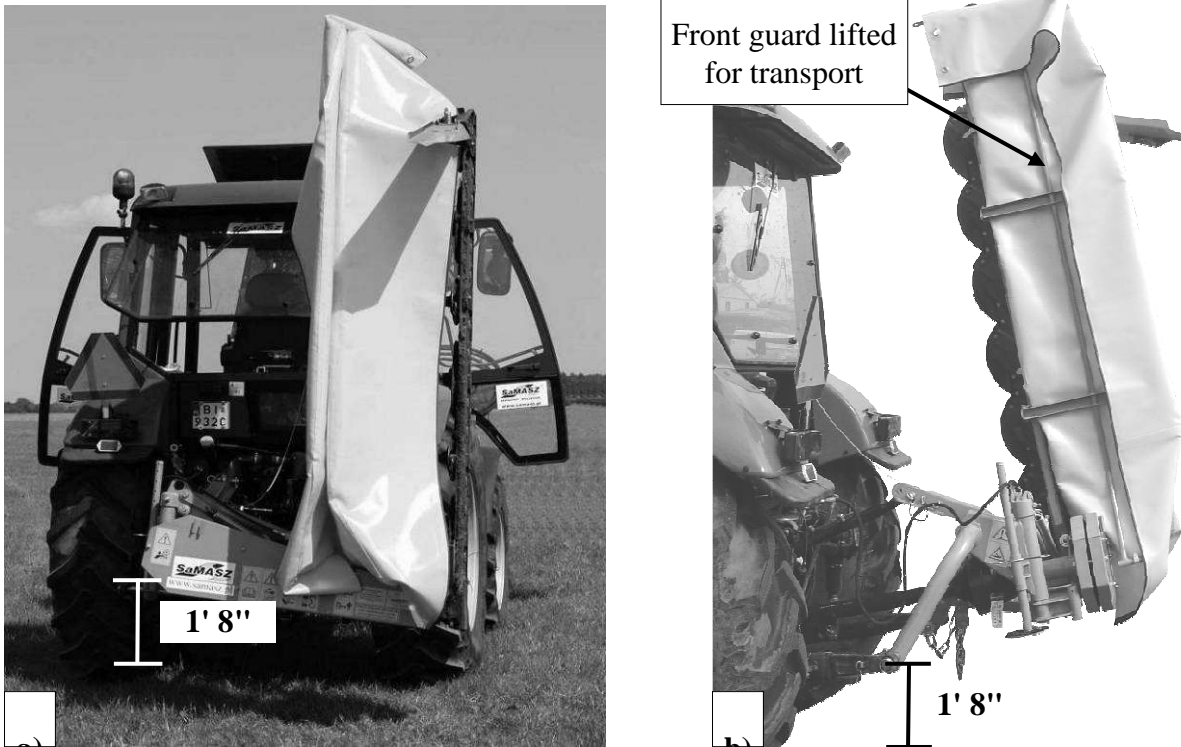

Fig. 13. Transport position

### 5.2. Preparing the mower for transport on public roads



**WARNING:**

Legal requirements for transport on public roads may differ from state to state. Check your location's requirements and comply.

To comply with safety precautions concerning transport on the public roads the mower should be equipped with the following devices:

- ❑ portable warning light plates to be mounted on both sides of mower top guard in their holders. The panel consists of warning plate with combined lamp mounted (parking, stop lights and driving direction) and with red reflectors facing the rear and white light on the front.

**NOTICE:**

warning-light plates can be ordered at the mower's manufacturer.

- ❑ plate for marking slow moving vehicles (being standard tractor equipment), which should be removed from the tractor and placed at the holder located at the belt gear's guard.

### 5.3. Mounting PTO shaft

PTO shaft's end with overrunning clutch should be mounted on mower's side. When connecting PTO shaft between tractor and mower make sure that external guard tube of the shaft is on the tractor's side. The PTO shaft plastic guards have to be secured by fastening their small chains to immovable parts of tractor and mower. The PTO shaft must operate at the lowest possible angle. This will ensure that both shaft and the machine last as long as possible.



**CAUTION:**

If need be, shorten the PTO haft according to its operator's manual given by the shaft's manufacturer (**Fig. 14**).

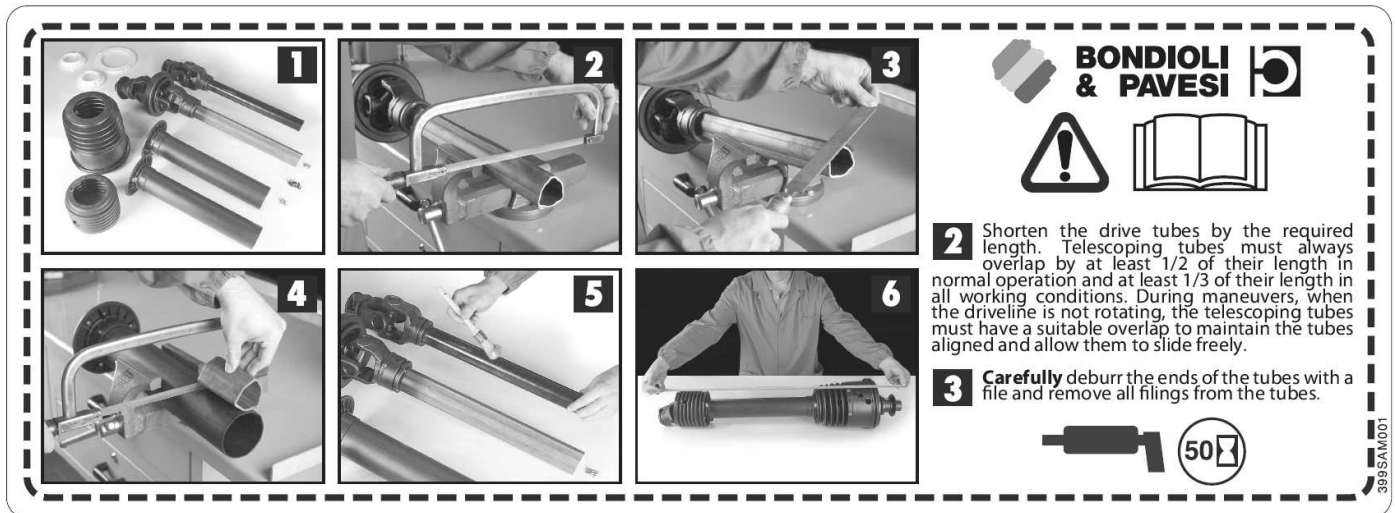

Fig. 14. Instruction of PTO shaft shortening



**CAUTION:**

Handle all parts with utmost care. Never place your hands or fingers between one part and the other. Wear safety clothes such as gloves, protective footwear and goggles. The operation of shortening must be carried out with the utmost care as the PTO shaft will have to be replaced if the telescopic shafts are shortened to an excessive extent.



**CAUTION:**

The PTO shaft should be mounted only during operation time and disconnected from tractor PTO for transport and service.

**NOTICE:**

The manufacturer declines all liability for damage caused by an incorrectly fitted or used PTO shaft.



**CAUTION:**

Use the machines with PTO shafts designed to drive them. Before the work begins, check the safety guards (in tractor, mower and PTO shaft), if they are placed correctly and are not damaged. Damaged or lost parts must be replaced with genuine ones. Make sure the PTO shaft is properly mounted. It is forbidden to approach the rotating parts, because it may lead to serious injuries or even death. All service and repair operations must be done only after the tractor engine has been stopped and ignition key off, all rotating parts have come to the complete standstill and the cutterbar is on the ground. Before the operation begins, read operator's manuals of both the machine and PTO shaft.

**5.4. Moving the mower from transport to working position**



**WARNING:**

Moving the mower to and from operating position from the transport position should only take place on even and stable ground. Prior to making the moves make sure whether there are no unauthorized persons exposed to any hazardous moving parts.

To safely move to the operating position, do the following:

- ❑ open the shut-off valve on the hydraulic cylinder (**Fig. 12a**),
- ❑ lower the mower until the cutterbar is at least 1' 3¾" above the ground (**Fig. 13**),
- ❑ make sure there is nobody in the place where you are going to lower the mower,
- ❑ tighten the cord until the lock **Z** (**Fig. 10b**) is released and using the hydraulic cylinder put the mower into a horizontal position,

- ❑ using the tractor's lever, slowly lower the cutterbar to the horizontal position,
- ❑ unblock the lock and lower the mower until the cutterbar touches the ground,
- ❑ by means of upper link (S) (Fig. 9) adjust the cutting height. Extending the link S increases the cutting height and shortening the link reduces it.
- ❑ lower the mower's front guard.

### 5.5. Preparing the mower for operation

#### NOTICE:

Before sale SaMASZ protects the cylinders with special grease against weather which may cause premature wear. Before operating the mower, remove the excess grease from the cylinders.

Engaging the mower's drive should be performed once the cutterbar is placed on the ground. The following should be performed in workplace and as mower is in operating position:

- ❑ Connect PTO shaft extension onto tractor's PTO shaft (if only one extension was taken out) or connect the complete PTO shaft,
- ❑ Optimal angle of cutterbar in relation to the ground should be between 2° and 3°. This angle can be achieved by tightening or extending the link. The same principle applies to mowers equipped with conditioner or rollers,
- ❑ Slowly engage the mower drive until cutting discs reach their nominal PTO rotating speed of 500 ÷ 540 rpm,
- ❑ engage tractor gear and start mowing. Flat meadows can be mowed at driving speed of 8 km/h (5 mph), however as unevenness occurs the speed should be reduced.

#### IMPORTANT:

If the pressure supporting the assembly of the cutterbars is too high, the cutterbars will not be able to lowered.

#### NOTE:

Too low a pressure in suspension disables the machine to be set in transport position. If locking pawl does not catch when mower is being switched to transport position, then increase pressure in suspension.

#### NOTE:

Improperly relieved cutting unit of the mower will cause increase of cutterbar pressure on the ground which will lead to faster wear of sliding skids, overload of cutterbar, higher fuel consumption, damage to the stubble and contamination of the fodder.

## 5.6. Operation

### 5.6.1. Basic information on mowing



#### WARNING:

The operator must be seated in the tractor's driver's seat when the machine is operating since only from that position is he able safely and properly operate the mower. Before he leaves the driver's seat, the operator must stop the engine, apply the parking brake and turn off the tractor engine.

Always use appropriate protective equipment (safety footwear, gloves, ear protection and dust mask).

Before using the machine, make sure that all the safety devices are in their correct positions and in a good condition. These safety devices must be immediately replaced if they are faulty or damaged. In

particular, the protective cover must be checked regularly. It must be immediately replaced if it is missing or damaged in any way.

**IMPORTANT:** If a disc mower is your first experience (you have mowed with 2-drum mower), you need a piece of essential information:

1. There is a difference - creased stubble, especially when it comes to lying grass. Straight grass may be mowed with horizontal adjustment of the mower and then the stubble will be even, but it will not look as attractive as with double-drum mowers. If the mower is inclined by approx.  $2^{\circ}$  to  $3^{\circ}$ , then the stubble line is wavy. After the grass is mowed, it stands up, which makes an impression of inaccurate mowing.
2. Disk mowers always leave some certain amount of uncut grass in disks, which when cutting grass forward are rotating in mowing direction – SAMBA 200 1 piece, while SAMBA 240 and 280 2 pieces each. It is a normal phenomenon. Practically, it is not possible to achieve such attractive stubble as in 2-drum mowers, because the knives work horizontally.

### 5.7.2. Essential information concerning mowing

#### Optimum work parameters

- ❑ Spline shaft rpm of 500–540 rpm.
- ❑ Too high a PTO rpm whirls the air, which may cause inclination of the grass in front of discs, which impairs the quality of mowing.
- ❑ Too low a PTO rpm impairs the quality of mowing and in some cases the mower stops mowing (too low linear velocity of the knife).
- ❑ Driving speed – recommended of min. 8 km/h (5 mph). – the faster, the better result. There is no restrictions on operating on even meadows – driving speed of even  $V = 30$  km/h (19 mph) can be applied.
- ❑ In case of mowing soft meadows, the pressure of the cutterbar on the ground should be reduced by adjusting support springs.
- ❑ Always check to make sure that the ground speed suits the conditions or work and that it does not create a potential source of danger.
- ❑ Do not take sharp turns anytime and do not operate in reverse.

### 5.6.2. Mower blocking

When operating the mower, pay attention to variable conditions on the field, which may cause the mower to block, such as: terrain unevenness, height and density of grass as well as other objects in the grass. In order to avoid blocking, mowing speed should be adjusted to the conditions. In order to take care of machine blocking, lower the cutterbar onto the ground, disconnect the drive and remove the ignition key. When eliminating the mower's blocking wear all appropriate protective gear.

#### NOTE:

When driving slower than  $V=5$  km/h (3 mph) flow of grass is disturbed, which will result in mower's blocking. Mowing quality is therefore impaired significantly.

- ❑ Disk mower stops mowing, if there is too much of water over the meadow or after long-term precipitations, which causes the ground to become very loose and it is recommended to wait until is dry,
- ❑ Laid grass can be mowed only at very low height, e.g. 1.18", as when cutting grass forward knives have to operate under some angle. In such case, stubble surface looks creased,
- ❑ Mowing laid grass with too low an incline may cause grass to wind onto drums and in result disk blocking,
- ❑ When operating on cultivated single season meadows or after long-term high precipitations, reduce pressure of the cutterbar by adjusting support spring, for the cutterbar may get blocked (pushing soil forward),

- ❑ SAMBA mowers mow well while keeping a straight line. It is recommended not to turn the machine into a grass windrow,
- ❑ For mowing both high straight and laid grass, in order to prevent blocking, dismount the right swath guide.

### 5.6.3. Driving the mower over windrows when taking turns

Lift the mower by means of hydraulic cylinder and take a turn (). Height of the lifted mower is enough to have a drive over windrows with no need of applying any other lifting by tractor's lifting devices. This is necessary, otherwise the cutterbar may get blocked with grass.

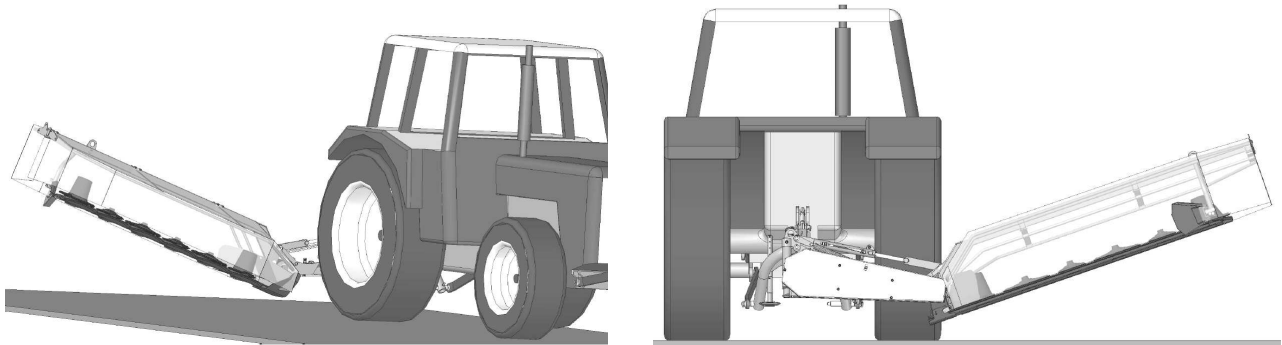

Fig. 15. Mower SAMBA ready to take turns

### 5.7. Unhitching the mower from tractor



**WARNING:**

When unhitching, make sure there is no person in between the mower and the tractor.

To unhitch the mower from the tractor:

- ❑ turn cutterbar's drive off,
- ❑ place the mower on an even, paved ground, then lower and inspect, if the mower is properly secured against falling,
- ❑ turn the tractor's engine off and remove the ignition key,
- ❑ disconnect the PTO shaft and place it on a PTO shaft holder, delivered with the mower as standard,
- ❑ disconnect hydraulic hose,
- ❑ disconnect both the tractor's upper link and the lower strands from the mower's linkage.

## 6. MOUNTING AND ADJUSTMENTS

### 6.0. Mounting and timing of the knives



**WARNING:**

- Use only knives recommended by manufacturer.
- Check condition of knives and holders before each operation. Worn or damaged knives should be replaced immediately.

Before mounting cutting knives, lift the mower's rear guard (**Fig. 19**). Mount the knives as shown in **Fig. 16**, **Fig. 17** and **Fig. 18**. The knives recommended by the manufacturer have dimensions of 105x49x4 and comply with the standard PN-EN 795:2002. Mount the knives so that cutting edges are directed towards the ground, so that a knife lifts the grass after cutting.

Tighten M12 nuts with socket wrench 18 mm (torque of 100-110 Nm). Before mounting or dismantling the knives, lock disks with square timber 2"x2".

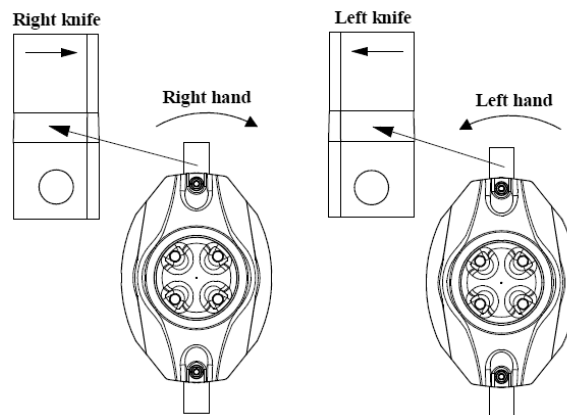

**Fig. 16.** Mounting of the knives on mowing discs

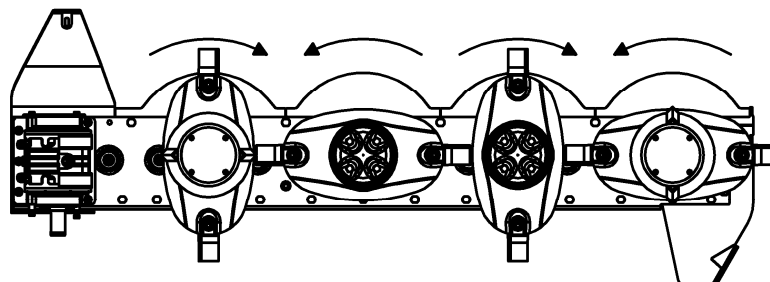

**Fig. 17a.** Direction of disk turns on mower SAMBA 160

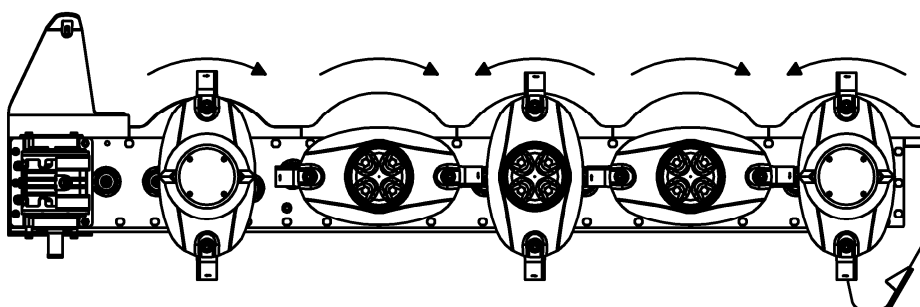

**Fig. 17b.** Direction of disk turns on mower SAMBA 200



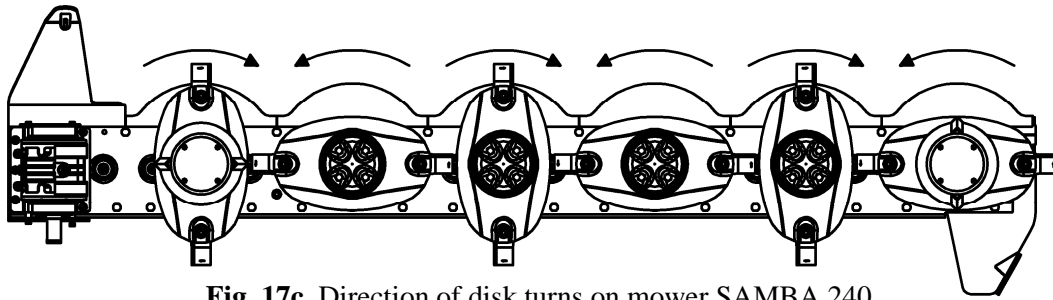

Fig. 17c. Direction of disk turns on mower SAMBA 240

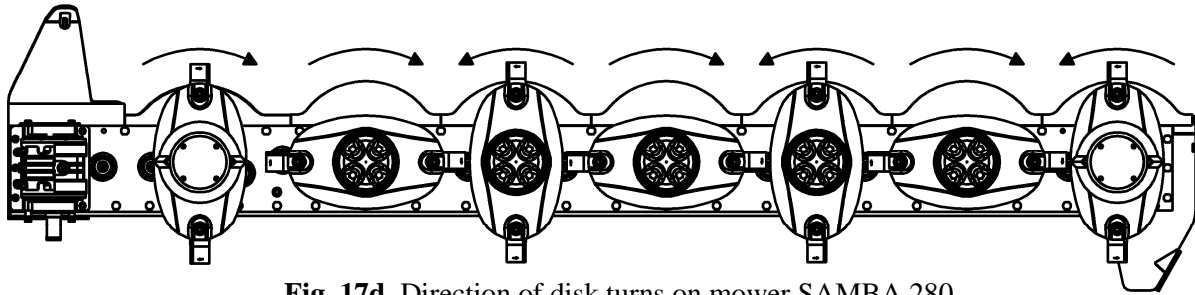

Fig. 17d. Direction of disk turns on mower SAMBA 280

### 6.1. Replacing the knives

Replace knives, if necessary, only in sets. Make sure all knives in a set are of the same length and weight. The knife holders (Fig. 18) must not be damaged or deformed. If the knife holder pin is worn too much, please replace it immediately (Fig. 20).

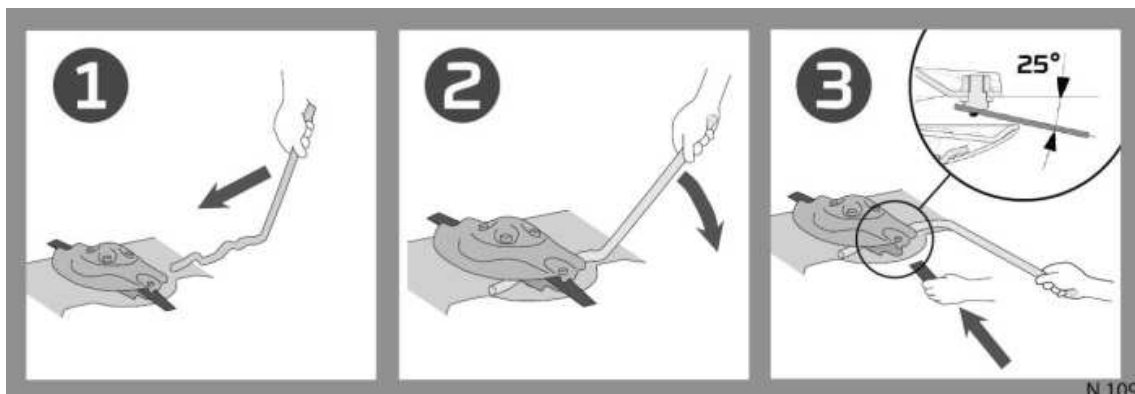

Fig. 18. Quick replacing of the knives with mounting lever

#### NOTICE:

During work, if mower begins to shake, it means that the disc (discs) are operating only with one knife. In that case, using the mower in this condition for a long time could cause serious damage to the cutterbar.



#### WARNING:

When replacing knives, the engine must be stopped and the cutterbar must lie on the ground. PTO shaft must be disconnected. Discs should be perpendicular to the cutterbar.

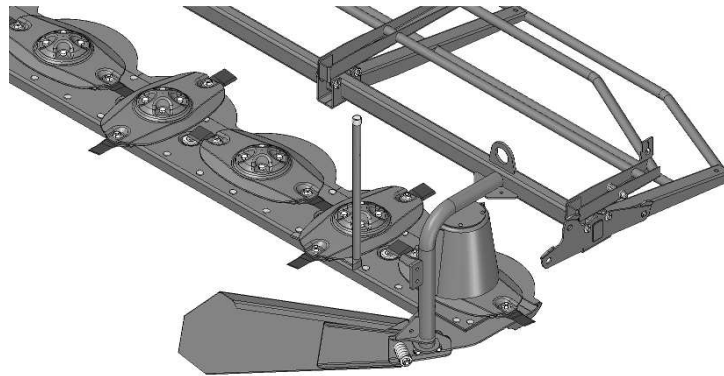

**Fig. 19.** Rear guard lifted for replacement of the knives

**NOTICE:**

Before you change the knife, check disc turns (**Fig. 17**).



**CAUTION:**

Improper mounting of the knives will block the mower. When mounting pay particular attention to the direction of disc's rotation.

To get the required mowing height, change length by means of upper link (**S**) (**Fig. 9**) to adjust the cutting height. Extending the link **S** increases the cutting height and shortening the link reduces it.

**6.2. Operating service**

**6.2.1. Controlling condition of knives and knife holders**

Replace knives, if necessary, only in sets. Make sure all knives in a set are of the same length and weight. The knife holders must not be damaged or deformed. If the knife holder pin is worn too much, please replace it immediately (**Fig. 20**).

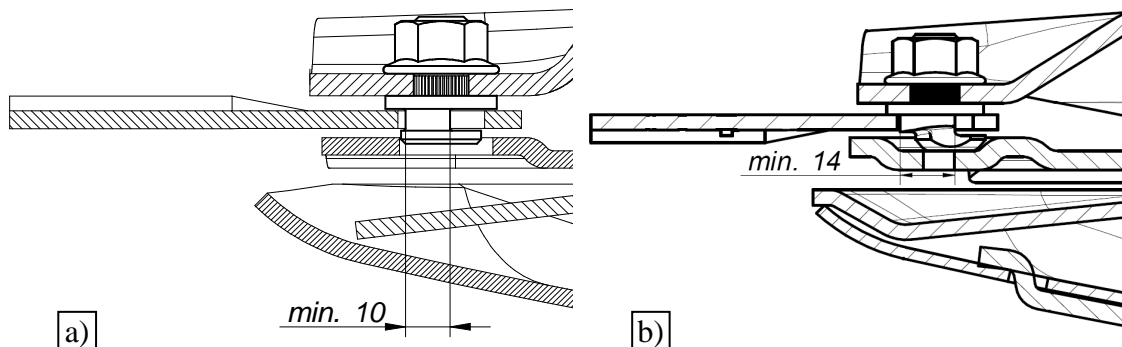

**Fig. 20.** Permissible wear of knife holder pin on disk a) knife base M12 b) knife base M12 with claw

### 6.2.2. Checking the tension of V-belts on belt gear

Tensioning of V-belts for belt gear is checked by means of tensioner index (**Fig. 21**). Distance (**S**) should be up max. 2". If belts are too loose, tighten tensioner nuts (**N**). If one of the belts is damaged, the whole set must be replaced.

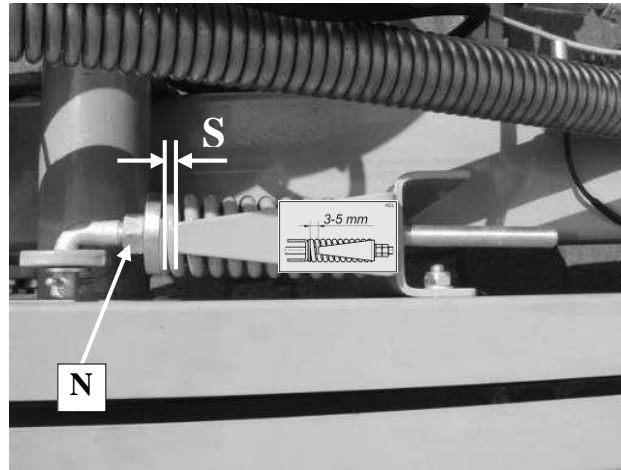

**Fig. 21.** Controlling tension of V-belts

### 6.2.3. Daily maintenance

When you finish each day of operation carry out the following maintenance:

- ❑ Check all visible parts and components and their connections; tighten all loose bolts and nuts and replace all damaged and/or worn parts with new genuine ones,
- ❑ Clean the mower, especially between discs and cutterbar, because grass with mud may damage bearings in disc module,
- ❑ Remove any grass and mud,
- ❑ Inspect the cutterbar,
- ❑ Grease PTO shaft tubes with STP grease,
- ❑ If necessary, lubricate the parts and components according to lubrication instructions (Section 7).

Parts which may cause risk to operator's health and safety are as follows: damaged discs, missing or damaged safety covers, worn or damaged hydraulic hoses, PTO shaft guides, worn knives and knife holder pins.

### 6.2.4. After-season maintenance and storing

At the end of mowing season the following shall be performed:

- ❑ Lower the mower's cutterbar onto the ground,
- ❑ Take the PTO shaft extension out of the tractor rpm or dismount the complete PTO shaft and place it into a corresponding holder on the 3-point linkage frame,
- ❑ Disconnect hydraulic and electrical hoses from the tractor and hang them onto corresponding holders on the 3-point linkage frame,
- ❑ Unhitch the mower from the tractor (reverse procedure as in case of attaching the mower to the tractor, see Section 5.8), and drive the tractor away.

Mower should be stored in standstill position, so it is supported onto supporting leg and the cutterbar. It is recommended to store the set on paved ground, preferably in roofed places, inaccessible to unauthorized personnel or animals.

If the machine is stored for a long period of time before first operation, its technical condition should be examined and special attention should be paid to the hydraulics and the drive. Paint the area where the paint is missing, hydraulic hoses checked and lubricated.

Additionally:

- ❑ Remove any traces of rust and paint the area affected,
- ❑ Check the oil level in the angle drives and the cutterbar (Section 7). If leaks are found, remove them immediately and refill the oil. If water in oil is found, immediately change the oil as it could cause corrosion of internal mechanisms such as gear wheels, bearings, or shafts, and thus breakdowns,
- ❑ Periodically inspect the mower and lubricate moving parts in order to protect them against corrosion having adverse effects on the proper operation of the mower,
- ❑ Check hydraulic hoses regularly. Replace any damaged or old hoses. Always replace hoses that have been in use more than 5 years from the date of their manufacture printed on them.

**IMPORTANT:**

When storing SAMBA mowers with hitch set vertically protect the cutterbar by means of wedge (K) (Fig. 22) against possible loss in stability, and in consequence mower's tipover.

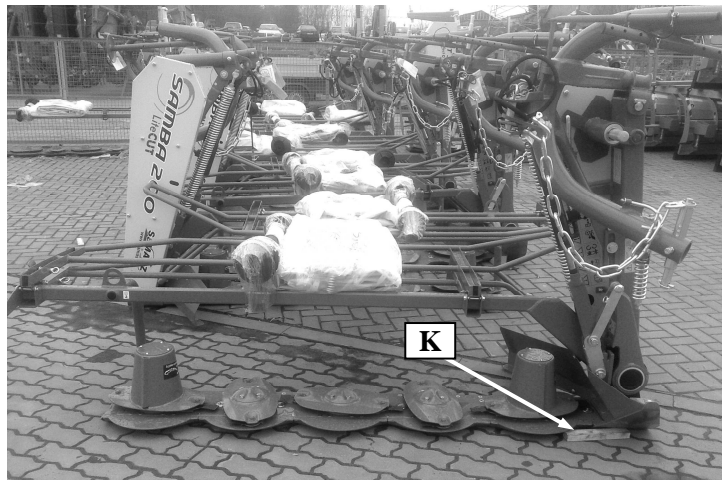

**Fig. 22.** Samba mower in vertical standstill position

## 7. LUBRICATION

### 7.0. Cutterbar

Refilling oil in the cutterbar is done through the inlet (A) (Fig. 23a). A Proper oil level is 0.2"-0.3" from the cutterbar bottom. Removing the old oil from the gearbox is done through the outlet (B) (Fig. 23b) in lower section of the cutterbar. Try to remove it immediately after the operation, if still warm.

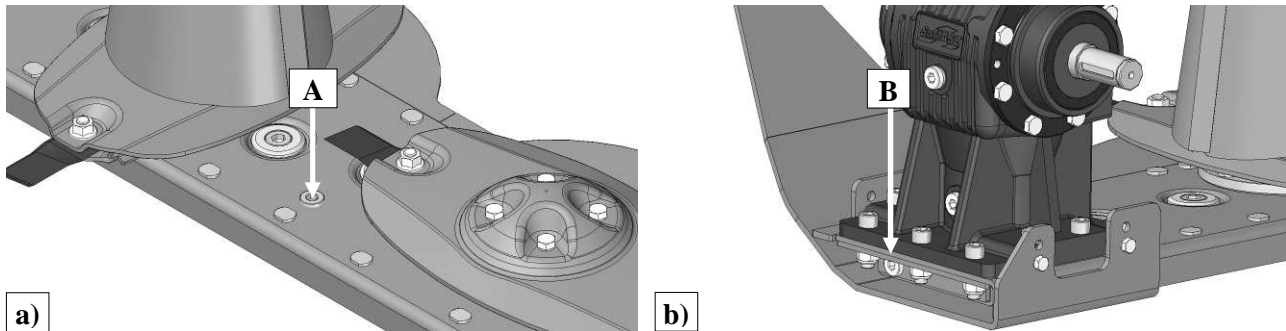

Fig. 23. Points of oil inspection and replacement on cutterbar

Tab. 4. Oil capacities in cutterbar

Mower type	Oil capacity [l]	Oil type	Replacement frequency
SAMBA 160	1.2	SAE 90 EP (ISO VG 320)	After first 50 h of operation, then after next 500 h (or at least once a year)
SAMBA 200	1.5		
SAMBA 240	1.8		
SAMBA 280	2.1		

### 7.1. Intersecting axis gear

Every day before starting work check the oil level and, if needed, refill after having removed the vent (A) (Fig. 24) on the top of the gear. The oil level can be checked through check opening (B). Please refill the oil until it is visible in the check opening (B). The oil capacity in the gear is about 0.7 L. Check oil level when the cutterbar is on the ground.

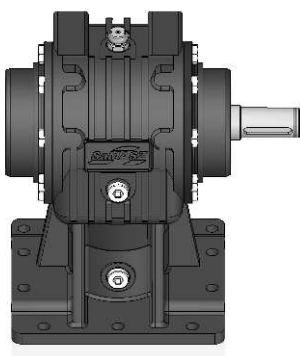

Tab. 5. Oil capacities in intersecting axis gear

Fig. 24. Points of oil inspection and replacement in intersecting axis gear

### IMPORTANT:

The above instructions should be strictly followed. If the discs in the cutterbar rotate loosely, do not worry about high intersecting axis gear temperature; after long working time, it may reach as much as 100°C.

## 8. MALFUNCTIONS AND THEIR REPAIR

**Tab. 6.** Defects and their repairs

Defect type	Reason	Repair
Mower stops mowing or leaves stripes of uncut grass between disks Small stripes of uncut grass SAMBA 160 – 1 stripe SAMBA 200 – 1 stripe SAMBA 240 – 2 stripes SAMBA 280 – 2 stripes	Some of knives (or their parts) are missing	Mount knives
	Worn knives	Replace knives
	Improperly mounted knives	Mount knives strictly according to instructions
	Too high PTO rpm	Reduce PTO rpm (recommended 1600 - 1800 rpm)
	Too low working speed	Speed up to V=10 km/h (6 mph) or more
	Transmission belts sliding	Springs not tightened enough - adjust these as per manual
		Worn v-belts - replace
	Damaged tractor's PTO shaft, drive not transmitted	Repair at service workshop
	Lying grass	The inclination - the angle zero
Mower with either tine or roller conditioner may mow improperly in case of very short grass or after rain		
Safety device is working often without clear reason	Spring in the device is not enough tensioned	Tension spring according to instructions
	Worn elements of safety device or improper adjustment	This repair must be done by SaMASZ service
V-belt catches fire	Mower is blocked with grass	Remove grass and/or mud from cutterbar
Mower does not work, even though the drive is transmitted from the tractor	Damaged intersecting axis gear or PTO shaft	Replace intersecting axis gear or examine PTO shaft
Mower is blocked	Damaged gears in the cutterbar	This repair must be done by SaMASZ service
Mower's hydraulics do not work	Damaged or dirty hydraulic cylinder and check valve	Replace or clean hydraulic connector and check valve
	Tractor's hydraulic system is damaged	Check tractor's hydraulic system
Mower is blocked with grass – no flow of grass or flow is uneven	Too low speed	Speed up to V=10 km/h (6 mph) or more
	Swath guides are spaced too tight	Space swath guides to their maximum
Leaking cylinder	Contaminated oil in tractor hydraulics	Replace oil in tractor hydraulics (recommended oil purity class acc. to NAS 1638 is 9-10). Order brand new cylinder repair kit and replace worn gaskets
Excessive vibration during work	Damaged PTO shaft	Check the condition of PTO shaft and if necessary replace
Oil leak in gear	Not tight assembly	Examine tightness and check oil level

## 9. DISASSEMBLY AND WITHDRAWAL FROM USE

### 9.0. Repair

Before any repair or service works clean the mower thoroughly and remove any grass, dirt or mud.

Carefully check nuts and bolts for adequate torque and pins for wear. If necessary, replace screws, pegs, V-belts, pins, bushings, disks, knives, knife holders, bearings etc.

#### NOTE:

Before any repair works disconnect the mower from the tractor.

### 9.1. Scrapping

When unhitching the machine pay particular attention to dangers involved such as possibility of crushing or cutting injury. Use special personal protective equipment: gloves, protective clothing, glasses etc. Pay attention not to let the machine lose its stability and secure it with supports.

If the mower cannot be repaired anymore, it should be withdrawn from use.

To do so, oil from intersecting axis gear and cutterbar should be drained and delivered to a proper waste treatment company. Clean the mower parts, dismantle and dispose properly of all plastic parts. After that, the mower can be scrapped.

## 10. WARRANTY CARD

### LIGHT CLASS REAR DISK MOWER

	Serial number Date of manufacture Manufacturer's stamp QC signature
--	--

	Date of purchase Dealer's stamp Dealer's signature
--	--

The product quality has been checked and meets the required standards and regulations and is permitted for use.

**NOTE:** A warranty card without the required information or with corrected or illegible information – **is invalid.**

## 11. WARRANTY TERMS

### 11.0. Warranty claims procedures

1. The manufacturer guarantees its products against faults in materials or production.
2. Warranty period is for two years from the date of sale to the purchaser, stated above.
3. Any repair which is subject to warranty should be carried out by an authorized SaMASZ dealer. Upon completion of the repair, the dealer must submit a warranty claim within 14 days.
4. Warranty claims regarding replacing of the product are considered if received within 14 days after it is completed by the manufacturer.
5. The following parts and situations are not covered by warranty:
  - a) **wearing parts: cutting plates, sliding skids, intersecting axis gears and parts inside the gearboxes, bushings and sliding elements, clutches, joints, knife holder, cutting knives, V-belts, sprockets, drive chain, conditioner's tines and rollers, roller conditioner's rubbers, bearings, rubber-metal fenders, safety curtains, conveyor's belts, swath guides rubbers, connective elements, etc.**  
These repairs may be done only at purchaser's cost.
  - b) **use for any other purpose than those described in the operator's manual,**
  - c) **operation on stony fields and results such as: damage of tine conditioner's shaft, discs, bending of cutterbar (stone with its diameter of 5.5" will not move between the discs and conditioner's shaft,**
  - d) **running into any obstacle,**
  - e) **too fast lowering of the cutterbar to the ground,**
  - f) **transport and accidental damage.**
6. The Purchaser bears the costs of technical evaluation - when the manufacturer finds that a claimed product is free of defects and a technical report confirms that.
7. The manufacturer has the right to cancel a warranty in the following cases:
  - a) **interference of the interior of the mower, changes of its mechanical design or intentional damages, bending parts of the mower and so on,**
  - b) **operating with only 1 knife on the disc or without disc cover plates,**
  - c) **damage caused by accidents, running into obstacles or other events, for which the warrantor is not responsible,**
  - d) **use of different knives - not original SaMASZ knives,**
  - e) **negligent maintenance,**
  - f) **use of non-genuine spare or replacement parts that are not specifically designed for the model in question,**
  - g) **lack of needed records in the warranty card or filling in the warranty card independently,**
  - h) **use of the mower not in accordance with operator's manual or for incorrect purpose, or use of the machine by untrained persons.**
8. Manufacturer can break the service agreement with immediate effect when the user does not pay the invoice according to that agreement in a timely manner and the delay in payment is longer than 30 days from maturity date. Breaking the service agreement caused by the user also invalidates the warranty.

### NOTE:

Please ask your dealer to complete and return the warranty card, otherwise you may lose your warranty rights.

The warranty card is valid only when it contains the following information: address, date and place of purchase, mower type and invoice number.



### 11.1. Warranty repairs record

Repairs description and changed spare parts:

Date, stamp and signature of repair shop.
---

Date, stamp and signature of repair shop.
---

Date, stamp and signature of repair shop.
---