



OPERATOR'S & PARTS MANUAL

MODEL M5 POWER BOX RAKE



The Power of Combined Excellence

SERIAL NUMBER: _____

MODEL NUMBER: _____

SN: M57A001 AND UP

MANUAL P/N: 51-4126

Notes

PREFACE

This manual describes the installation, operation, and maintenance of the Harley Power Box Rake. Read and understand the manual in its entirety before performing installation, operation or maintenance in order to ensure the equipment's optimum level of performance. Read and follow all safety and precautionary notes included in this text.

Throughout this manual, references are made to front, back, right and left directions. These are determined by sitting in the operator's seat of the prime mover.

REMINDER: Fill in the warranty card and mail within 10 days of your purchase date. While filling in the card with the correct information, put the date purchased and the serial number on the front cover of this manual. Should you need to call your dealer or Harley Attachments, this information will help them to more quickly provide accurate service for you.

Any questions related to this should be directed to Harley Attachments customer service at **800-456-7100**.

TABLE OF CONTENTS

OWNER ASSISTANCE	2
SPECIFICATIONS.....	3
BOLT TORQUE CHART	4
SAFETY STATEMENTS	5
GENERAL SAFETY PRECAUTIONS.....	5-7
EQUIPMENT SAFETY PRECAUTIONS	7-9
SAFETY DECAL AND SERIAL TAG PLACEMENT.....	10-11
OPERATIONAL PROCEDURE	12-18
MAINTENANCE	19-23
TROUBLE SHOOTING	24-25
ASSEMBLY, PARTS IDENTIFICATION.....	26-46
WARRANTY POLICY	47

OWNER ASSISTANCE

Harley Attachments, LLC and your authorized Harley dealer want you to be completely satisfied with your investment. To resolve any problems that may occur, please contact the Service Manager of your local Harley dealer. If your problem has not been handled to your satisfaction, contact:

Customer Service (8:00am – 5:00pm EST)
Harley Attachments, LLC
2800 N. Zeeb Road
Dexter, MI 48130-9499
734-996-9116
800-456-7100
Parts Fax: 734-996-9014

Please be prepared to provide the following information:

- Your name, address, and telephone number
- Machine model and SERIAL NUMBER
- Dealership name and address
- Machine purchase date
- Nature of problem

Local Dealer Information:

Contact: _____
Address: _____
Phone #1: _____
Phone #2: _____
Email: _____

SPECIFICATIONS

Raking Width	62"
Roller Type	Tooth Roller Standard 9" Diameter
Roller Angle (ANGLING MODEL ONLY)	20 Degrees Both Directions
Gap (Tube to Barrier)	1-1/8" - 2-1/2" Adjustable
Skid-steer Lift Capacity Requirement	SAE Lift Capacity 1,200 lbs
Skid-steer Hydraulic Requirement.....	13 GP @ 2500 psi (min.)
Tires	16.5 x 6.5 - 8
Tire Pressure	60 psi
Weight Straight Rake	798 lbs
Angling Rake.....	938 lbs
Oil Capacity of Chain Case	Approximately 1.5 Pints

BOLT TORQUE CHART

After every ten (10) hours of operation, check all hardware and tighten where required.

SAE Series Torque Chart

DO NOT use these values if a different torque value or tightening procedure is listed for a specific application. Torque values listed are for general use only.

Fasteners should be replaced with the same grade.

Make sure fastener threads are clean and you properly start thread engagement. This will prevent them from failing when tightening.

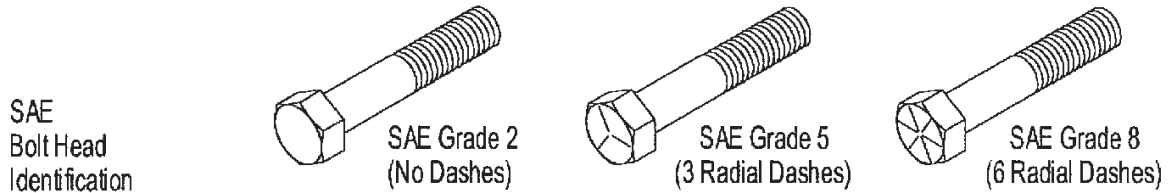

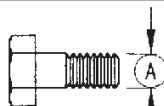
Bolt Diameter "A"	Wrench Size	MARKING ON HEAD					
		SAE 2		SAE 5		SAE 8	
		Lbs.-Ft	(N-m)	Lbs.-Ft	(N-m)	Lbs.-Ft	(N-m)
1/4	7/16	6	(8)	11	(15)	14	(19)
5/16	1/2	13	(18)	21	(28)	25	(34)
3/8	9/16	23	(31)	38	(52)	55	(75)
7/16	5/8	37	(50)	55	(75)	80	(110)
1/2	3/4	57	(77)	85	(115)	120	(165)
9/16	13/16	82	(111)	125	(170)	180	(245)
5/8	15/16	111	(150)	175	(240)	230	(310)
3/4	1 1/8	200	(270)	300	(410)	440	(600)
7/8	15/16	280	(380)	450	(610)	720	(975)
1"	1 1/2	350	(475)	680	(925)	1035	(1400)
1 1/8	1 11/16	450	(610)	885	(1200)	Bolt Diameter 	
1 1/4	1 7/8	600	(815)	1255	(1700)		
1 3/8	2 1/16	675	(915)	1620	(2200)		
1 1/2	2 1/4	920	(1250)	2200	(2900)		

Metric Series Torque Chart

Use only metric tools on metric hardware. Other tools may not fit properly. They may slip and cause injury.

Bolt Diameter "A"	Wrench Size	MARKING ON HEAD			
		8.8		10.9	
		N-m	(Lbs.-Ft)	N-m	(Lbs.-Ft)
5 mm	8 mm	6	(4.5)	9	(6.5)
6 mm	10 mm	10	(7.5)	15	(11)
8 mm	13 mm	25	(18)	35	(26)
10 mm	16 mm	50	(37)	75	(55)
12 mm	18 mm	85	(63)	130	(97)
14 mm	21 mm	110	(80)	150	(110)
16 mm	24 mm	215	(159)	315	(232)
20 mm	30 mm	435	(321)	620	(457)
24 mm	36 mm	750	(553)	1070	(789)
30 mm	46 mm	1495	(1103)	2130	(1571)

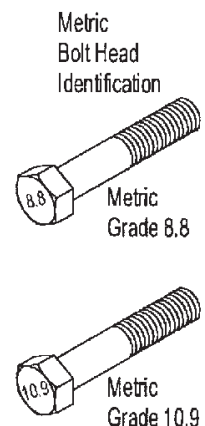

SAFETY STATEMENTS



DANGER

This statement is used where serious injury or death will result if the instructions are not followed properly.



WARNING

This statement is used where serious injury or death could result if the instructions are not followed properly.



CAUTION

This statement is used where minor injury could result if the instructions are not followed properly.

NOTICE

This statement is used where equipment or property damage could result if the instructions are not followed properly.



This symbol by itself or used with a safety signal word throughout this manual is used to call your attention to instructions involving your personal safety or the safety of others. Failure to follow these instructions can result in injury or death.

GENERAL SAFETY PRECAUTIONS



WARNING

READ MANUAL PRIOR TO INSTALL

Improper installation, operation, or maintenance of this equipment could result in serious injury or death. Operators and maintenance personnel should read this manual as well as all manuals related to this equipment and the prime mover thoroughly before beginning installation, operation, or maintenance.

FOLLOW ALL SAFETY INSTRUCTIONS IN THIS MANUAL AND THE PRIME MOVERS MANUAL.



WARNING

READ AND UNDERSTAND ALL SAFETY STATEMENTS

Read all safety decals and safety statements in all manuals prior to operating or working on this equipment. Know and obey all OSHA regulations, local laws and other professional guidelines for your operation. Know and follow good work practices when assembling, maintaining, repairing, mounting, removing, or operating this equipment.



KNOW YOUR EQUIPMENT

Know your equipment's capabilities, dimensions, and operations before operating. Visually inspect your equipment before you start and never operate equipment that is not in proper working order with all safety devices intact. Check all hardware to assure it is tight. Make certain that all locking pins, latches, and connection devices are properly installed and secured. Remove and replace any damaged, fatigued, or excessively worn parts. Make certain all safety decals are in place and are legible. Keep decals clean and replace them if they become worn and hard to read.

WARNING

PROTECT AGAINST FLYING DEBRIS

Always wear proper safety glasses, goggles, or a face shield when driving pins in or out or when any operation causes dust, flying debris, or any other hazardous material.

WARNING

LOWER OR SUPPORT RAISED EQUIPMENT

Do not work under raised booms without supporting them. Do not use support material made of concrete blocks, logs, buckets, barrels, or any other material that could suddenly collapse or shift positions. Make sure support material is solid, not decayed, warped, twisted, or tapered. Lower booms to ground level or onto blocks. Lower booms and attachments to the ground before leaving the cab or operator's station.

WARNING

USE CARE WITH HYDRAULIC FLUID PRESSURE

Hydraulic fluid pressure can penetrate the skin and cause serious injury or death. Hydraulic leaks under pressure may not be visible. Before connecting or disconnecting hydraulic hoses, read your prime movers operator's manual for detailed instructions on connecting and disconnecting hydraulic hoses or fittings.

- Keep unprotected body parts, such as face, eyes, and arms as far away as possible from a suspected leak. Flesh injected with hydraulic fluid may develop gangrene or other permanent disabilities.
- If injured by injected fluid, see a doctor at once. If your doctor is not familiar with this type of injury, ask him to research immediately to determine proper treatment.
- Wear safety glasses, protective clothing, and use a sound piece of card board or wood when searching for hydraulic leaks. **DO NOT USE YOUR HANDS! SEE ILLUSTRATION BELOW.**

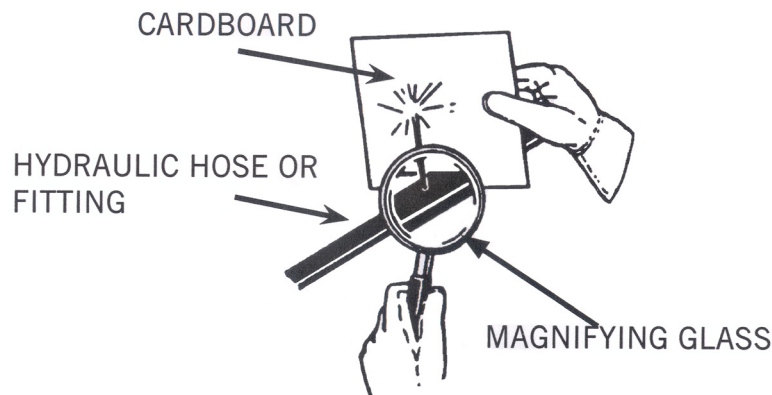

WARNING

DO NOT MODIFY MACHINE OR ATTACHMENTS

Modifications may weaken the integrity of the attachment and may impair the function, safety, life, and performance of the attachment. When making repairs, use only the manufacturer's genuine parts, following authorized instructions. Other parts may be substandard in fit and quality. Never modify any ROPS (Roll Over Protection System) equipment or device. Any modifications must be authorized in writing by the manufacturer.

 **WARNING****SAFELY OPERATE EQUIPMENT**

Do not operate equipment until you are completely trained by a qualified operator in how to use the controls, know its capabilities, dimensions, and all safety requirements. See your prime movers manual for these instructions.

- Keep all step plates, grab bars, pedals, and controls free of dirt, grease, debris, and oil.
- Never allow anyone to be around the equipment when it is operating or being serviced.
- Do not allow riders on the attachment or the prime mover.
- Do not operate the equipment from anywhere other than the correct operators position.
- Never leave equipment unattended with the engine running or with this attachment in a raised position.
- Do not alter or remove any safety feature from the prime mover or this attachment.
- Know your work site safety rules as well as traffic rules and flow. When in doubt on any safety issue, contact your supervisor or safety coordinator for an explanation.

 **WARNING****SAFELY MAINTAIN AND REPAIR EQUIPMENT**

- Do not wear loose clothing or any accessories that can catch in moving parts. If you have long hair, cover or secure it so that it does not become entangled in the equipment.
- Work on a level surface in a well lit area.
- Use properly grounded electrical outlets and tools.
- Use the correct tool for the job at hand. Make sure they are in good condition for the task required.
- Wear the protective equipment specified by the tool manufacturer.

EQUIPMENT SAFETY PRECAUTIONS

NOTICE

Safety is a primary concern in the design and manufacture of our products. Unfortunately, our efforts to provide safe equipment can be wiped out by a single careless act of an operator. In addition, to the design and configuration of equipment, hazard control and accident prevention are dependent upon the awareness, concern, prudence, and proper training of personnel involved in the operation, transport, maintenance, and storage of equipment. The designed and tested safety of this equipment depends on it being operated within the limitations as explained in this manual.

 **WARNING****INITIAL SET-UP AND SYSTEMS CHECK**

- Always check with your skid-steer manual or dealer for counter weight ballast that may be required for machine stability.
- Air in hydraulic systems can cause erratic operation and allows loads or equipment components to drop unexpectedly.
- Before operating equipment purge any air in the system by engaging all hydraulic functions.
- Check that all control lever positions function as instructed in the

Operator's Manual. Do not operate until control lever and equipment movements are correct.

- Make sure all hydraulic hoses, fittings, and valves are in good condition and not leaking before starting power unit. Check and route hoses carefully to prevent damage.
- Hoses must not be twisted, bent sharply, kinked, frayed, pinched, or come into contact with any moving parts.
- Operate moveable components through full operational range to check clearances. Replace damaged hoses immediately.
- Ensure implement is properly attached, adjusted, and in good condition. Skid-steer coupler lock-pins must be fully extended and properly engaged into attachment retaining slots.
- Skid-steer must be equipped with ROPS and seat belt/operator restraint. Keep seat belt/operator restraint securely fastened/engaged. Falling off skid-steer can result in death from being run over or crushed. Keep ROPS systems in place at all times.



SAFELY OPERATE EQUIPMENT

Improper operation can cause the machine to tip or roll over and cause injury or death.

- Keep skid-steer lift arms and attachment as low as possible.
- Do not travel or turn with skid-steer lift arms and attachment raised.
- Turn on level ground.
- Go up and down slopes, not across them.
- Keep the heavy end of the machine uphill.
- Do not overload the machine.
- Never use the skid-steer attachment to carry loads that exceed skid-steer rated operating capacity or other skid-steer specifications. Check your skid-steer manual or with your dealer for skid-steer rated operating capacity. Exceeding this capacity can cause machine to tip or roll over and cause injury or death.
- Use of a front safety door on the skid-steer is recommended for operation of the Power Box Rake®.
- Only engage power when equipment is at ground level. Always disengage power when equipment is raised off the ground.
- Do not disconnect hydraulic lines until all system pressure is relieved.
- Never go underneath equipment lowered to the ground or raised. Hydraulic system leak down, hydraulic system failures, mechanical failures, or movement of control levers can cause equipment to drop or rotate unexpectedly and cause severe injury or death.
- Never direct discharge toward people, animals, or property.
- Do not operate equipment while under the influence of alcohol or drugs.
- Operate only in the daylight or good artificial.
- Always comply with all state and local lighting and marking requirements.
- Ensure equipment is properly attached, adjusted, and in good operating condition. Skid-steer coupler lock-pins must be fully extended and properly engaged into attachment retaining slots.

 **WARNING**

WATCH FOR OPERATING HAZARDS

- Look down and to the rear and make sure area is clear before operating in reverse.
- Watch for hidden hazards on the terrain during operation.
- Use extreme care when working close to fences, ditches, other obstructions, or on hillsides.
- Reduce ground speed on slopes and rough terrain.
- Do not operate on steep slopes.
- Do not stop, start, or change directions suddenly on slopes.
- Stop skid-steer and implement immediately upon striking an obstruction. Dismount skid-steer using proper procedure. Inspect and repair any damage before resuming operation.

 **WARNING**

MAINTENANCE SAFETY

- Your dealer can supply original equipment hydraulic accessories and repair parts. Substitute parts may not meet original equipment specifications and may be dangerous.
- Avoid electrical system hazards. Never work on the electrical system unless you are qualified and thoroughly familiar with system details and the special handling requirements.
- Disconnect battery before working on electrical system. Remove “ground” cable first. When reconnecting battery, connect “ground” cable last.
- Never perform service or maintenance with engine running.
- Tighten all bolts, nuts, and screws, and check that all cotter pins are installed securely to ensure equipment is in a safe condition before operating.

 **WARNING**

EXPOSURE TO RESPIRABLE CRYSTALLINE SILICA DUST ALONG WITH OTHER HAZARDOUS DUSTS MAY CAUSE SERIOUS OR FATAL RESPIRATORY DISEASE.

It is recommended to use dust suppression, dust collection and if necessary personal protective equipment during the operation of any attachment that may cause high levels of dust.

SAFETY DECAL AND SERIAL TAG PLACEMENT

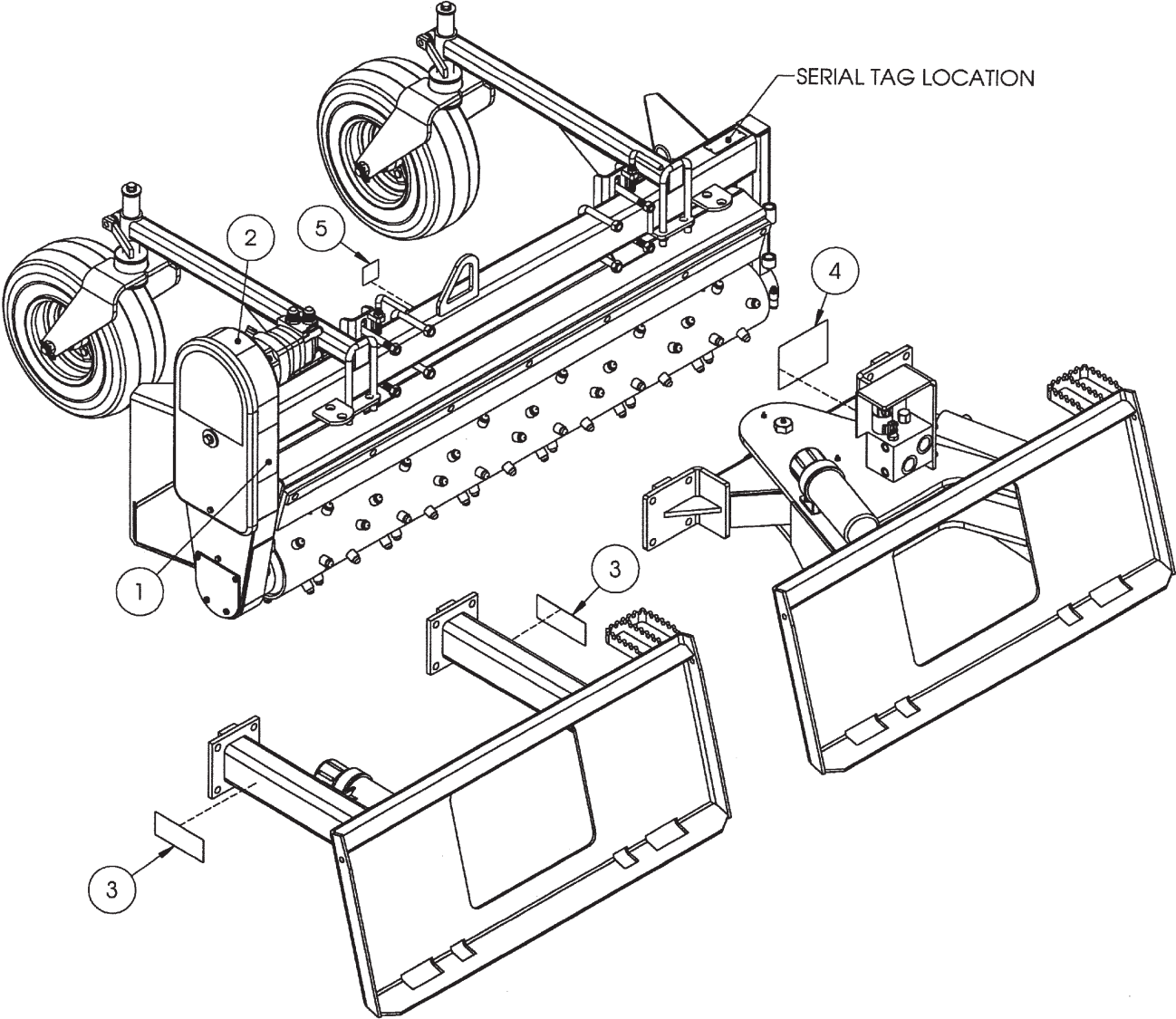

Figure 1. Safety Decals

SAFETY DECALS

	⚠ WARNING 
	
<p>BEFORE ATTACHING, CHECK SKID STEER LOADER LIFT CAPACITY TO ENSURE ITS ABILITY TO SAFELY HANDLE THE WEIGHT.</p> <p>DO NOT OPERATE WITHOUT GUARDS/SHIELDS IN PLACE AND IN GOOD WORKING ORDER.</p> <p>STOP ALL MOVING PARTS INCLUDING SKID STEER LOADER ENGINE BEFORE CLEANING, UNPLUGGING, ADJUSTING, AND/OR PERFORMING MAINTENANCE.</p> <p>KEEP BYSTANDERS 10 FEET FROM POWER RAKE WHEN IN OPERATION.</p>	
P970004	

#1 - PN: P970004

⚠ DANGER	
	
<p>ROTATING PART HAZARD</p> <ul style="list-style-type: none"> * KEEP HANDS, HAIR AND CLOTHING AWAY FROM MOVING PARTS. * CLOSE AND SECURE ALL SHIELDS BEFORE OPERATING. <p>FAILURE TO DO SO COULD RESULT IN SERIOUS INJURY OR DEATH</p>	

#2 - PN: P970300

⚠ DANGER	
	
<ul style="list-style-type: none"> • Stay at least 10 feet (3m) away from operating equipment. • Flying objects and rotating parts can cause injury or death. • Stop engine before cleaning or servicing. • Keep all guards in place. 	
P970250	

#4 - PN: P970250

	HARLEY	MODEL #
PALADIN LIGHT CONSTRUCTION		<input type="text"/>
JAMESTOWN, ND 58402 USA		SERIAL #
FX # 701-252-1978 PH # 701-252-9300		<input type="text"/>

SERIAL # TAG

	⚠ DANGER
	<p>Stay at least 10 feet (3m) away from operating equipment.</p> <p>Flying objects and rotating parts can cause injury or death.</p> <p>Stop engine before cleaning or servicing.</p> <p>Keep all guards in place.</p>
P970251	

#3 - PN: P970251

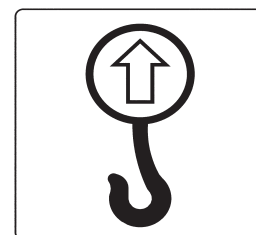

#5 - PN: P976500

OPERATIONAL PROCEDURE

NOTICE

The M.5 Power Box Rake® is designed for removing rock and small debris, and for thatching. Skid-steers must be equipped with an auxiliary hydraulic system capable of supplying continuous flow for hydraulic motor operation. This manual contains information for the M.5 straight and angling models. Refer to the information in this manual for specifications, parts, assemblies, and adjustments.

ATTACHING POWER RAKE TO SKID-STEER

Read the skid-steer Operator's Manual connecting and removing instruction.

Position hydraulic hoses so they will not be pinched when connecting the power rake.

The skid-steer coupler handles should be in the unlocked position and the lock pins retracted.

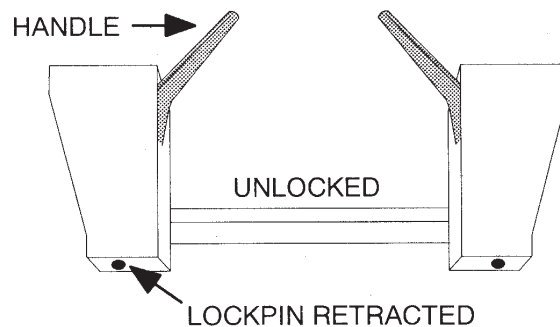

Figure 2. Skid-Steer Coupler Handles - Unlocked

Move to the skid-steer operator seat and start engine.

Lower skid-steer lift arms to their lowest position.

Carefully move and align the skid-steer to the power rake. The top of the skid-steer coupler must index into the power rake flange, see **Figure 3 below**.

Roll the skid-steer coupler into the power rake so the coupler handles can be engaged.

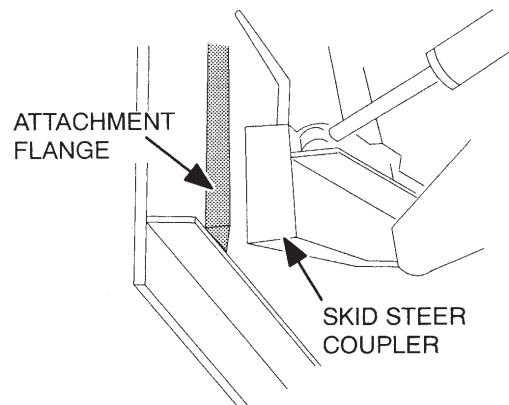

Figure 3. Attaching Power Rake to Skid-Steer

Shut off the engine, set brake, and remove key. Dismount the skid-steer.

OPERATIONAL PROCEDURE

Move the skid-steer coupler handles to the locked position. The lock pins must be completely extended and secured into the slots provided on the power rake, see **Figure 4** and **Figure 5** below.

Connect hydraulic hoses to skid-steer auxiliary quick couplers.

For hydraulic angling models, mount the angle control switch in a convenient, easy-to-reach location. The switch bracket is magnetic and will attach to any flat steel surface. Connect the power cord to the cable coming from the switch. Be careful when routing the cable that sharp edges or moving parts will not damage the cable.

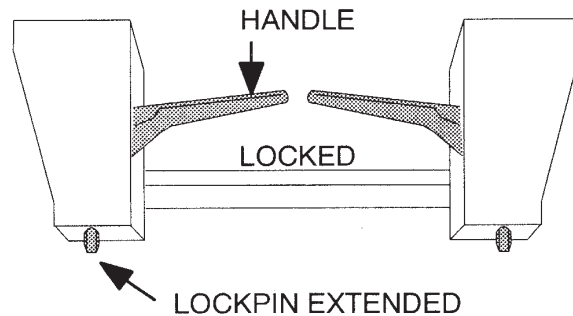

Figure 4. Skid-Steer Coupler Handles - Locked

Back View of Attachment

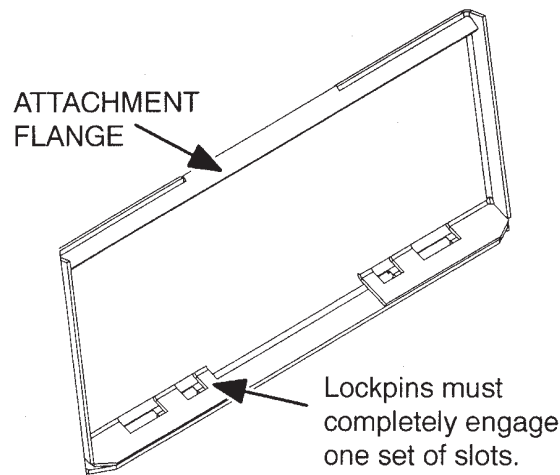

Figure 5. Back of Attachment - Slot Locations

POWER RAKE FUNCTION

The power rake hydraulic motor drives the roller, which digs into the ground, cultivating and pulling up rocks, roots, and debris.

The clean soil goes between the roller and barrier, while the rocks, roots, and debris work to the side in a windrow.

With the endplates mounted in the working position and the rake straight (endplates parallel with skid-steer tires), material can be moved along, filling in the low spots. Also, rocks, roots, and debris can be collected and moved to another location for hauling away.

OPERATIONAL PROCEDURE

Start prime mover engine.

Lower power rake slowly to the ground.

Engage hydraulic control lever for auxiliary implements.

Increase engine rpm to give desired rpm at the roller. Normal operating speed is approximately 270 rpm. If operating in heavy rock, reduce the speed slightly.

Move the prime mover forward or backward as desired. For the roller to operate effectively, it must rotate in the opposite direction of the prime mover wheels, see **Figure 6 below**. Roller rotation direction is controlled by prime mover hydraulic controls.

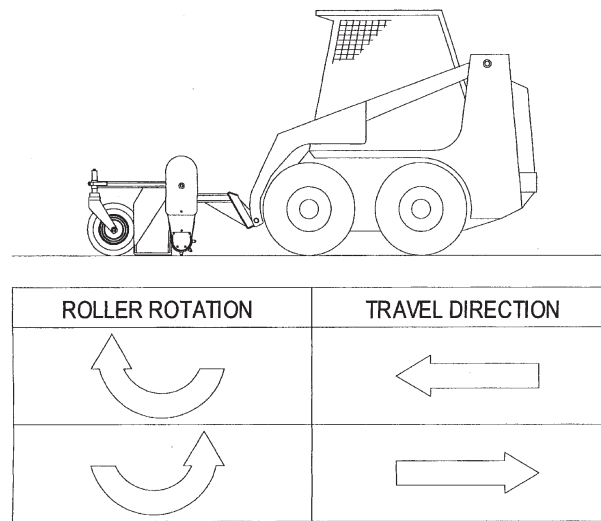

Figure 6. Roller Rotation

Ground Speed

Ground speed should be between 3 and 5 mph under normal conditions. In heavy rock, reduce the ground speed to 1 to 3 mph.

Direction Control Switch (HYDRAULIC ANGLING MODEL ONLY)

A three position switch is provided to angle the rake left or right. The switch is equipped with a magnetic mount and may be attached to a convenient steel surface near the operator. The direction valve uses a small amount of hydraulic oil bypassed from the roller drive motor and will only operate with the prime mover auxiliary hydraulic system engaged and with the roller turning clockwise.

With the prime mover auxiliary hydraulic system engaged, move the spring loaded switch in one direction and the rake will angle left or right. Return the switch to center position and rake will maintain the angle selected. Pivot rake to place the windrow left or right of the skid-steer.

Hydraulic Drive Motor

The hydraulic drive motor runs off the auxiliary circuit of the prime mover. The power rake should be run at 30% power for one hour for proper motor break-in.

OPERATIONAL PROCEDURE

Power Roller

Roller should be level with the ground. The power rake should also be level with the ground front to back. To accomplish this, raise or lower gauge wheels and/or use the prime mover tilt cylinder.

To allow the roller to penetrate deeper into the ground, loosen the handle and raise the gauge wheels. To achieve the opposite, lower the gauge wheels.

The chain case end of roller weighs 90 lbs. more than the other end of roller. To compensate for this, you should set the tire closest to the chain case down 1" lower than opposite tire. This will still give an even grade when landscaping.

During operation, further depth control can be achieved by tilting the rake forward on gauge wheels to raise roller, or by tilting the rake back to raise gauge wheels and allow more roller penetration.

Be sure to check the air pressure in each tire regularly so that an even, consistent grade will be maintained.

The normal gap between the roller and barrier for average conditions is about 1-1/4". This gap can be adjusted either wider or narrower by loosening the 5/8" carriage bolts (4) that holds the barrier mount and sliding it up or down. A wider opening will allow more dirt and rock to pass through. For finer raking, reduce the gap. Be careful not to let roller hit barrier. The gap should be the same all the way across. Barrier adjustment is shown in **Figure 7 (page 18)**.

The roller on the power rake is **bi-rotational**. You can operate the roller in both directions clockwise and counter-clockwise. The roller operates most efficiently when it rotates in the opposite direction of the prime mover wheels.

Operating Depth

When power raking, the depth will determine how much dirt is carried ahead of the roller. The ideal depth will vary with conditions and can be anywhere from skimming the surface to about 3" deep. See instructions in **Power Roller** above to set roller depth.

When making the first windrow (angling model only), the level of dirt may be halfway up on the barrier. When moving the windrow two or three times, the level of the dirt may be to the top of the barrier. However, try to prevent material from flowing over the top.

The power rake allows fast raking of large areas of ground by being able to move windrows several times. Of course, the volume or density of the material being raked will dictate how many times a windrow can be moved.

Endplates

The function of the endplates is to contain the material in front of the roller while the clean material passes between the roller and barrier.

With the endplates mounted in the working position and the roller straight (parallel with prime mover), material can be moved along, filling in the low spots.

OPERATIONAL PROCEDURE

By decreasing the gap between the roller and barrier, more material can be pulled along. Barrier adjustment is shown in **Figure 7 (page 18)**.

These plates can be mounted to the front or back of the power rake, depending on the raking direction. When you move the endplates from front to back, you must move the left one to the right side and the right one to the left side.

Make sure the disconnected power rake is stored on a hard, level surface. Use the endplates mounted on attachment side of rake to ensure stability.

Operator Production

Successful operation of the power rake will come with operator experience. The rake's performance also depends on the type and size of the prime mover it's mounted on.

An operator that masters the technique of adjusting the angle of attack of the roller against the soil will also find ideal settings under various conditions to give the desired results.

NOTICE

Do not drop power rake to the ground with the roller turning. Sudden high speed jolts multiply stress to the drive line and can cause extreme damage.

Parallel Arms (Float Model Only)

The function of the parallel arms is to allow the power rake to "float" and follow the contour of the ground. Lock-out pins are supplied to allow more aggressive action. However, the hydraulic motor may stall out if too much down-pressure is applied. See **Figure 7 (page 18)** for pin "float" and "lock-out" positions.

Application Techniques

The power rake is capable of many applications. The following are some of the common applications:

Pulverizing Topsoil

For breaking up compacted soil or conditioning hardened baseball diamonds, the attachment plate is rolled back to take the guide wheels off the ground so only the toothed roller is in contact with the ground. Maintain sufficient RPM to avoid stalling the toothed roller in its progress. The rake can be straight or angled, but the endplates should not be mounted in order to allow material to move out of the way and not slow the process.

Debris Removal

Once the surface has been loosened, the process of removing debris can begin. The prime mover attachment plate is tilted forward until the guide wheels control the depth of the toothed roller. The roller can be angled at this time for windrowing debris or the roller can be set straight with both endplates installed to collect debris. Prime mover travel speed should be increased for this process.

Finish Grading

The rake is tilted forward until the teeth of the toothed roller are barely touching the soil. Prime mover speed can be increased for this operation, the idea being to collect material from the high spots and leave it in the low areas.

OPERATIONAL PROCEDURE

Spreading Fill and Topsoil

Position so it is tilted on gauge wheels, since depth of cut is not the objective. Endplates can be installed and the windrow angle set as needed to control the material movement.

Changing Grade

Grade modification can be accomplished during finish grading by angling the rake to collect and windrow the maximum amount of material toward targeted areas.

Thatching Existing Grass Areas

The prime mover attachment plate should be tilted forward to support the rake on the front gauge wheels and toothed roller raised so teeth are just grazing the surface. Travel speed should be slow and careful.

Shutting Down

Stop engine.

Lower the lift arms and power rake to the ground.

Purge any air in the system. Hydraulic system leak down, hydraulic system failures, mechanical failures, or movement of control levers can cause equipment to drop or rotate unexpectedly.

Shut off engine, set brake, remove key, remove seat belt, and release operator restraint before leaving the prime mover operator's seat.

Install endplates on attachment side of power rake as shown in **Figure 7 (page 18)**.

On a hard level surface, lower attachment to the ground.

Shut off engine, set brake, remove key, remove seat belt, and release operator restraint before leaving the prime mover operator's seat.

Move attachment coupler latches to the unlocked position (lock pins must be disengaged).

Disconnect hydraulic hoses from quick couplers. Install dust plugs and couple hoses together for storage. Disconnect direction control switch from prime mover power cord and remove switch.

Move to prime mover seat and start engine. Release brake and roll attachment coupler until it is disengaged from the attachment. The attachment should rest in a stable position for storage.

STORAGE

Make sure the disconnected power rake is stored on a hard, level surface. Endplates mounted on attachment side of rake increase stability.

 **WARNING** Block equipment securely for storage.

 **CAUTION** Keep children and bystanders away from storage area.

OPERATIONAL PROCEDURE

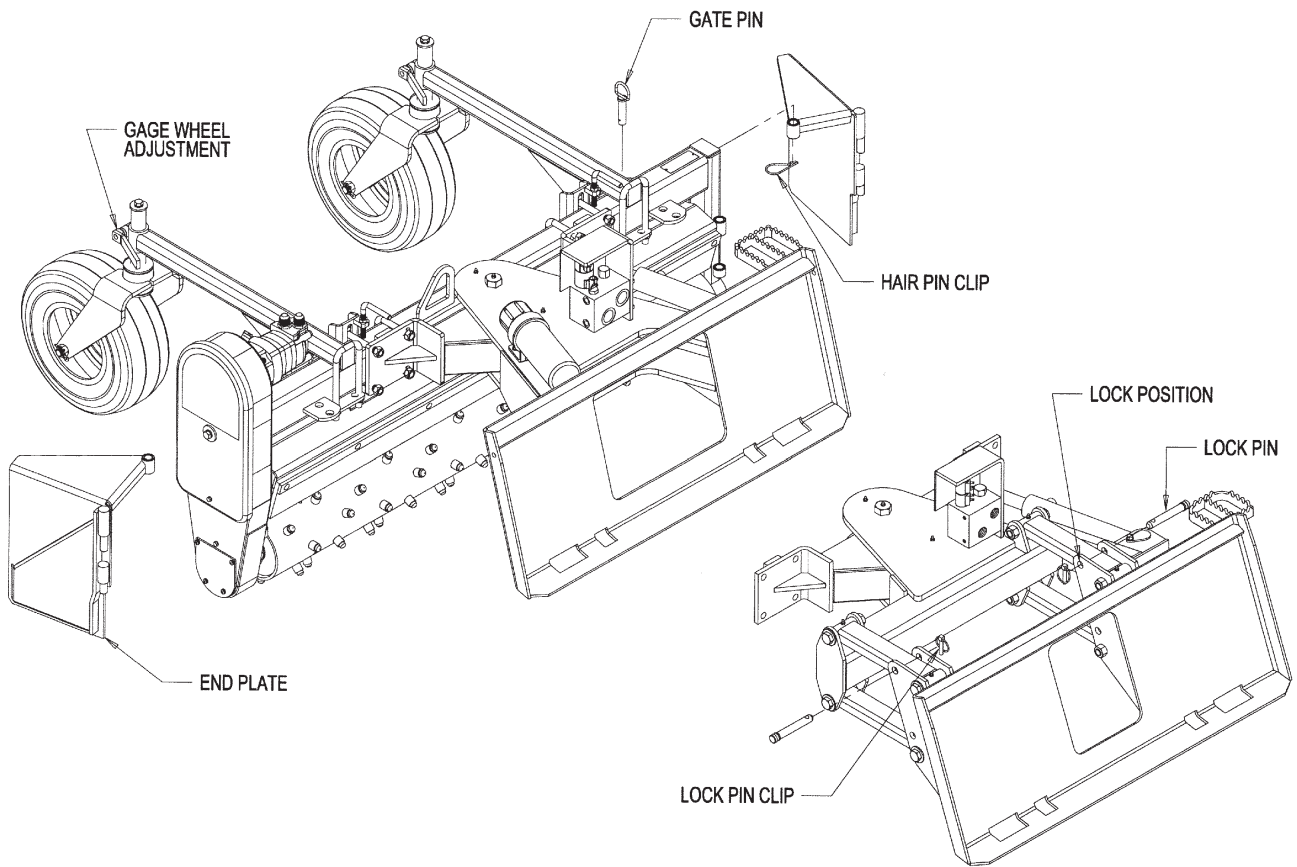

Figure 7. Adjustments

MAINTENANCE

The information in this section is written for operators who possess basic mechanical skills. Should you need help, your dealer has trained service technicians available. For your protection, read and follow all safety information in this manual.

Regular preventive maintenance and immediate repair of broken or worn parts will ensure maximum efficiency and long life.

Because of the nature of the jobs the power rake does, such as site preparation and rock raking, the power rake is constantly vibrating and shaking. Parts may loosen up as it is used. One of the most important functions an operator can perform is observing and inspecting the equipment for loose or worn parts to prevent further damage or excessive downtime.

PROCEDURE	INTERVAL
Inspect prime movers hydraulic system to be sure the level of hydraulic oil is adequate.	daily
Repair hydraulic oil leaks.	daily
Lubricate all grease fittings.	weekly
Check tire pressure.	weekly 60 psi cold
Inspect and clean safety decals. Replace if damaged. (See safety decals section for location.)	monthly
Inspect drive chain.	monthly
Check oil level in chain case.	monthly
Change lubrication in chain case. (add 1.5 pints of #00 fluid gear grease)	quarterly

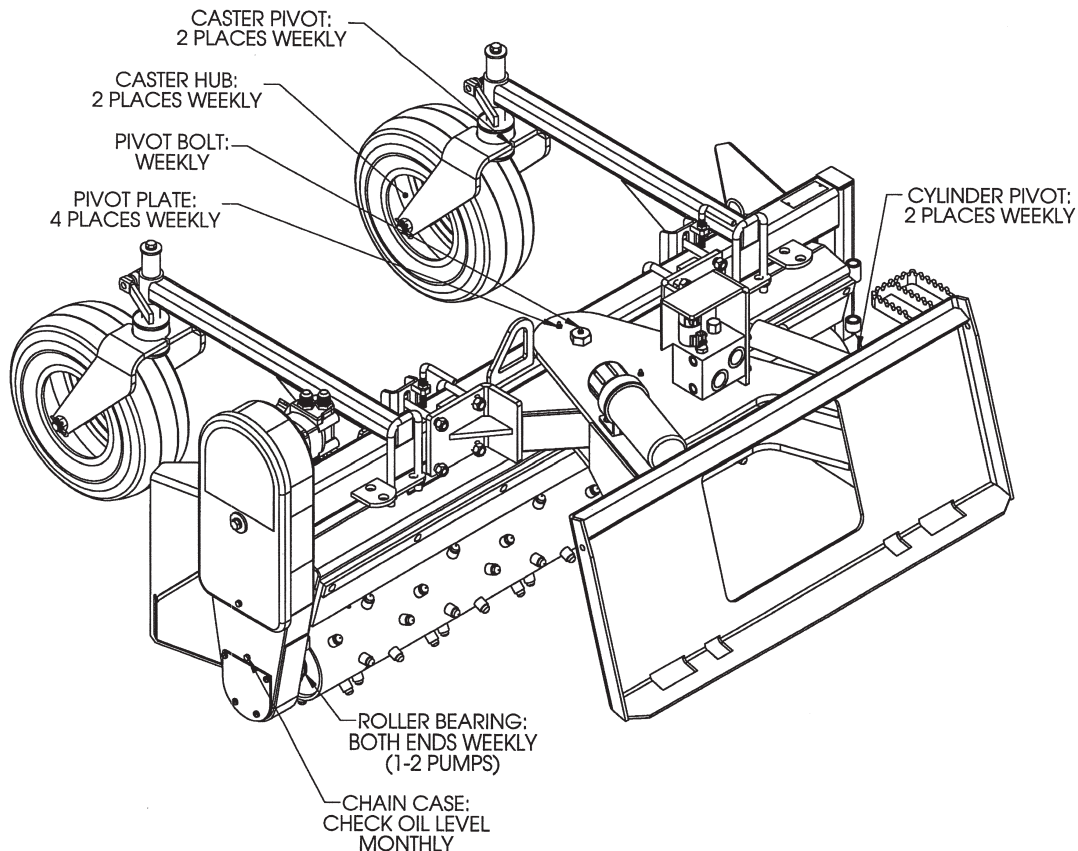

Figure 8. Lubrication Maintenance

MAINTENANCE

CHAIN MAINTENANCE

The drive chain should be inspected monthly. New chain has a tendency to stretch, so it is necessary to check in the chain tension to prevent flopping around, thus causing potential problems.

Chain tension is preset with the extension spring. If the chain becomes excessively loose, it may be necessary to remove one link (two pitches). If unable to reassemble, add an offset link to lengthen the chain.

NOTICE

Replacement chain should be only high quality original equipment chain for longer life.

When being stored for a long period or at end of season, change the oil, adding #00 fluid gear grease, and rotate the roller several times allowing the chain to be coated with lubricant, enhancing chain life. Rotate the roller periodically to maintain lubrication. In order to rotate the roller and chain you must connect the two hydraulic hoses together.

SPROCKETS

Sprockets should be checked to be sure slotted hex nut or hex bolt is tight, the cotter pin is in place, and the sprocket cannot move on shaft.

QUALIFIED TECHNICIAN MAINTENANCE

HYDRAULIC MOTOR

Removal

Remove chain from top sprocket. Then remove top sprocket by removing the hex bolt and washers.

Reassemble

Apply a liberal amount of silicone sealer to inside of flange. Attach hydraulic motor to chain case with four bolts and flange nuts. Replace shaft collar. Slide top sprocket (sprocket teeth first) onto shaft. Use machine bushings on the inside or outside of sprocket for proper alignment.

BEARINGS

Highest quality bearings are used on the power rake. Only triple-seal bearings are used on the roller which operates down in the dirt. Lubrication of the bearings will vary considerably with conditions. As a rule, bearings should be under-lubricated rather than over-lubricated. Over lubrication can cause seals to blow out.

NOTICE

Replacement bearings should be only high quality original equipment bearings for longer life.

Install new complete bearing housing if needed or just replace the bearing insert. The shafts should be straight, free of burrs, and up to size. If shaft is worn, replace or have the shaft built up to standard prior to completing assembly.

MAINTENANCE

Protective Collars

The special protective collars protect bearings from vine and wire wrap, and dirt buildup next to the bearing seal. The bearing protector is sandwiched onto the shaft which rotates within a close clearance from the outer race of the bearing. Grease coming from the bearing oozes into the protecting collar, keeping dust and particles from entering the seal area, increasing the bearing life.

Left Roller Bearing

1. Remove drive chain. Then remove lower sprocket by removing cotter pin, slotted hex nut, and washers.
2. Remove the two bolts holding the chain case to the frame.

NOTICE

Have roller blocked up or supported.

3. Slide chain case and bearing off roller shaft.
4. Loosen bolt on the bearing tube that holds cartridge bearing in place.
5. Remove bearing and O-ring.

To replace, reverse the procedure. Be sure all parts and wear surfaces are thoroughly clean and in good condition.

When replacing bearing, first put O-ring on bearing. Apply a coat of grease on O-ring. Slide bearing in and apply moderate pressure on bearing so O-ring will seat and spread slightly, thus keeping the oil in chain case from escaping through the bearing.

Right Roller Bearing

1. Remove the hex bolt and bearing cap from outside of bearing.
2. Loosen bolt on the bearing tube that holds cartridge bearing in place.
3. Pry bearing tube apart to free bearing assembly.

NOTICE

Have roller blocked up or supported.

To replace, reverse the procedure. Be sure all parts and wear surfaces are thoroughly clean and in good condition.

MAINTENANCE

ROLLER REPLACEMENT

NOTICE

It will be necessary to have a lifting device or additional help while removing and replacing the roller. The roller weighs approximately 140 lbs.

1. Remove upper and lower chain case covers.
2. Remove tension spring and drive chain.
3. Remove lower sprocket by removing cotter pin, slotted nut, and washers.
4. Remove spacers behind the sprocket that was just removed.

NOTICE

Have the roller blocked up or supported.

5. Remove two bolts holding chain case to frame and slide chain case, with hydraulic motor attached, off of the roller shaft. The roller bearing will stay in the chain case.
6. Loosen the bolt on the bearing tube of the non-drive end.
7. Slide roller and bearing out of frame.
8. Remove hex bolt, bearing cap, bearing, and protective collar from roller.
9. On roller to be installed, place machine bushing and protective collar against endplate on roller.
10. Place bearing and bearing cap on roller.
Clamp in place with hex bolt and lock washer into end of roller shaft.
11. Slide roller and bearing into bearing tube on non-drive end of frame. Do **not** tighten bearing tube at this time.
12. Place spacers, protective collar, and O-ring from splined end of removed roller onto replacement roller. Check O-ring for cuts and nicks.
13. Apply sealant to bearing area on shaft.
14. Slide chain case back onto roller and bolt to frame.
15. Replace spacers, sprocket, and washers on drive shaft.
16. Clamp solid with 1" slotted jam nut.
17. Check that roller clears the frame on both ends (adjust, if required).
18. Tighten 3/8" bolt in bearing tube on non-drive end of frame.
19. Reinstall chain and tension spring.
20. Replace lower cover, being careful not to pinch the O-ring.
21. Fill the chain case with 1.5 pints of #00 fluid gear grease
22. Replace upper cover.
23. Run power rake and watch for any interference between roller frame.

MAINTENANCE

DIRECTIONAL CONTROL VALVE (HYDRAULIC ANGLE MODEL ONLY)

A three position switch (normally open) is used to operate the direction control valve. Control power (12 volt) is supplied by the power cord attached to the prime movers electrical system. The switch wires are connected to the direction control valve as shown in **Figure 9 below**.

The direction control valve uses a small amount of hydraulic oil bypassed from the roller drive motor circuit. The prime movers auxiliary hydraulic system must be connected and engaged to provide angle direction adjustment. The roller must be rotating clockwise.

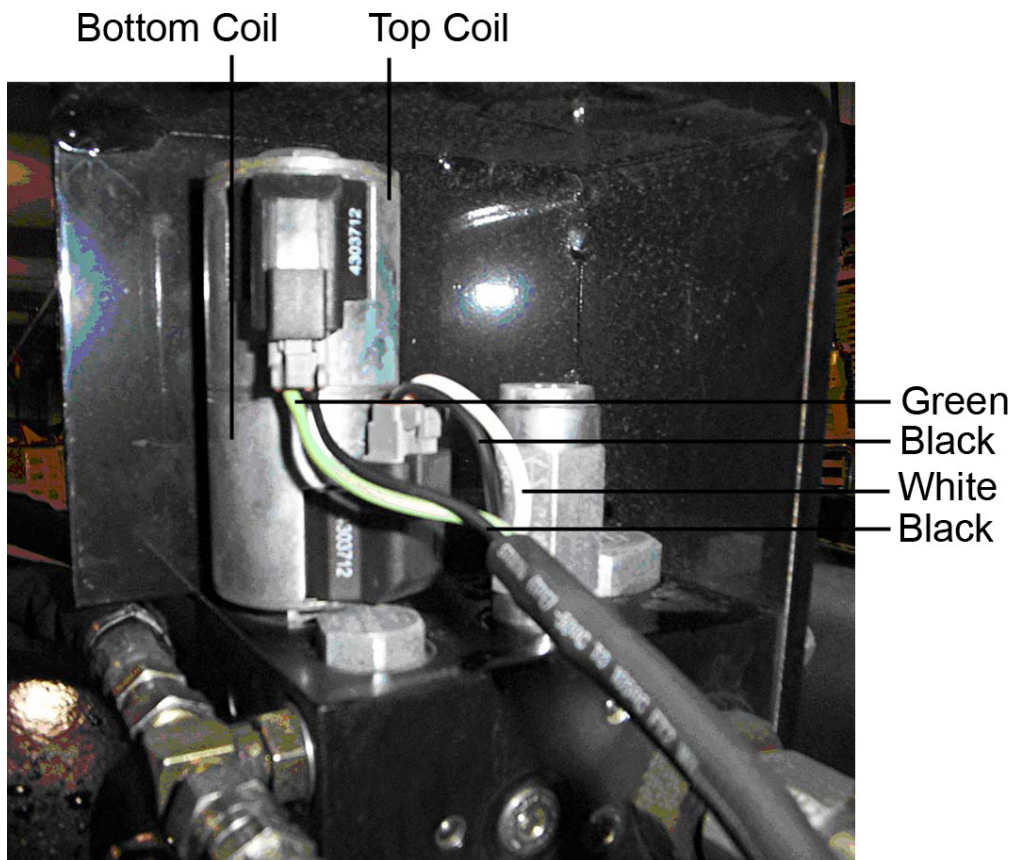

Figure 9. Direction Control Valve

TROUBLE SHOOTING

Problem	Possible Cause	Solution
Roller will not turn.	<p>Hydraulic valve on skid-steer not engaged.</p> <p>Relief valve setting on skid-steer not properly adjusted.</p> <p>Worn, damaged, insufficient, or inadequate pump.</p> <p>Insufficient oil in system.</p> <p>Hose ends not completely engaged.</p> <p>Air in hydraulic lines.</p> <p>Obstruction in hydraulic lines.</p> <p>Obstruction between roller and barrier.</p> <p>Chain off.</p>	<p>See skid-steer Operator's Manual for auxiliary hydraulic operation procedure.</p> <p>Have skid-steer dealer set relief valve at correct pressure.</p> <p>Repair or replace hydraulic pump.</p> <p>Service the skid-steer hydraulic reservoir.</p> <p>Check hose coupling and engage properly.</p> <p>Cycle skid-steer auxiliary system several times to remove air from lines.</p> <p>Replace obstructed or damaged line.</p> <p>Reverse roller to clear obstruction.</p> <p>Repair or replace chain.</p>
Oil leaks.	<p>Worn or damaged seal.</p> <p>Loose or damaged hoses.</p> <p>Loose or damaged connections.</p> <p>Worn or damaged housing.</p> <p>Roller out of position.</p>	<p>Replace leaking seal.</p> <p>Replace damaged hoses and secure loose hoses.</p> <p>Replace damaged hose connections and tighten loose fittings.</p> <p>Replace damaged housing.</p> <p>Loosen bearing collar on frame and chain case. Force roller toward chain case, then tighten bearing collars on chain case and frame.</p>

TROUBLE SHOOTING

Problem	Possible Cause	Solution
Angle cylinder will not extend or retract.	Electrical failure. Hydraulic system not activated.	See skid-steer Operator's Manual. Engage roller drive motor before attempting to move angle cylinder.
Angle cylinder will not hold position.	Check valve in manifold malfunctioning. Solenoid cartridge not returning to closed position.	Repair or replace check valve. Repair or replace solenoid cartridge.

ASSEMBLY/PARTS IDENTIFICATION

SET-UP INSTRUCTIONS

The power rake is shipped partially assembled. Assembly will be easier if components are aligned and loosely assembled before tightening hardware. Recommended torque values for hardware are located on page 4.

Select a suitable working area. Refer to illustrations, accompanying text, parts lists, and exploded view drawings.

For reference, front, back, left and right directions are determined by sitting in the prime movers operator's seat.

It is advisable to have a mechanical lifting device to facilitate uncrating.

UNPACKING CRATE

Be careful of nails in boards when uncrating.

1. Remove top, sides, and ends of crate.
2. Remove attachment plate.
3. Remove gauge wheel assemblies.
4. Remove right and left endplates.
5. Remove rake assembly from crate.
6. Remove loose nails from boards and dispose of crate according to local codes.

STRAIGHT MODEL ASSEMBLY PROCEDURE (See Figure 10)

Tools Required

15/16" combination wrench

1. Stand rake frame upright and position one endplate on each side of frame to stabilize the rake.
2. Attach the two gauge wheel assemblies to main frame using two 5/8" U-bolts and locking nuts as shown in **Figure 10 (page 28)**.
3. Position the attachment mount plate on the frame and clamp in place with two 5/8" U-bolts, two 5/8" carriage bolts and locking nuts.
4. Check the oil level in the chain case. If needed, add #00 fluid gear grease. See instructions near fill/vent plug, **Figure 15 (page 40)**.

ASSEMBLY/PARTS IDENTIFICATION

ANGLING MODEL (NON-FLOAT) ASSEMBLY PROCEDURE (See Figure 11 & Figure 15)

Tools Required

15/16" combination wrench

1. Stand rake frame upright and install endplates on attachment side of frame to stabilize.
2. Attach the two gauge wheel assemblies to main frame using two 5/8" U-bolts and locking nuts as shown in **Figure 11 (page 30)** and **Figure 15 (page 40)**.
3. Install power cord by connecting the red clamp to a positive 12 volt power source and the black clamp to ground. The power cord includes an in-line fuse and spring-loaded battery clamps. The red (positive) cable is fused and should always be connected to the positive side of the battery to ensure proper operation of the electrical circuit. Be careful when routing the cable that sharp edges or moving parts will not damage it.
4. Check the oil level in the chain case. If needed, add #00 fluid gear grease. See instructions near fill/vent plug, **Figure 15 (page 40)**.

ANGLING MODEL (WITH FLOAT) (See Figure 13)

Tools Required

15/16" combination wrench

1. Raise front of rake up so pivot frame is horizontal.
2. Mount left and right endplates.
3. Move attachment mounting plate into position.
4. Attach four link arms to the attachment plate (lower arms first).
5. Tighten nuts after all four arms are in place.
6. Replace the 3/4" X 4-3/4" pins in either the "lockout" or "float" positions.
7. Attach the two gauge wheel assemblies to main frame with two 5/8" U-bolts and Locking nuts as shown in **Figure 11 (page 30)**.
8. Check the oil level in the chain case. If needed, add #00 fluid gear grease. See instructions near fill/vent plug, **Figure 15 (page 40)**.

ASSEMBLY - STRAIGHT MODEL

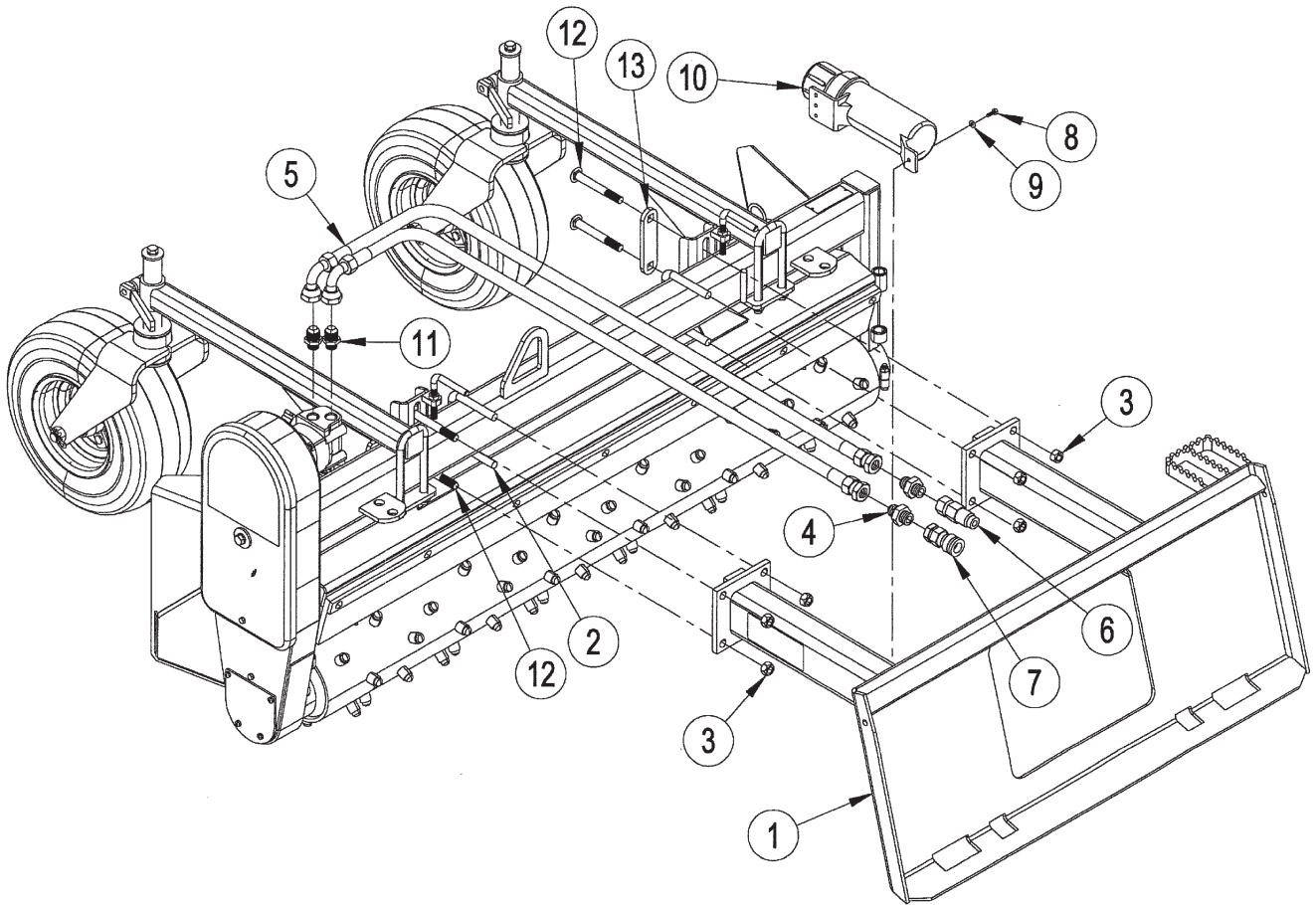

Figure 10. Straight Model Assembly

ASSEMBLY - STRAIGHT MODEL PARTS LIST

<u>ITEM</u>	<u>QTY</u>	<u>PART NO.</u>	<u>DESCRIPTION</u>
1	1	M16055PG	Attachment Mount
2	2	P128440	5/8" X 4" X 4-1/4" U-Bolt
3	8	P157500	5/8"-11 Top Lock Nut
4	2	P276450	12MJ-12MB Adapter
5	2	P255737	-10 Hose X 68" 12FJX-12FJX90°
6	1	P272670	Male Flat Face Coupler
7	1	P272671	Female Flat Face Coupler
8	3	P102403	1/4"-28 X 3/4" Bolt
9	3	P850104	1/4" Washer
10	1	P136000	Manual Tube
11	2	P276440	12MJ-10MB Fitting
12	4	P104920	5/8"-11 X 5" Carriage Bolt
13	2	M15040PG	Carriage Bolt Strap

ASSEMBLY - ANGLING MODEL

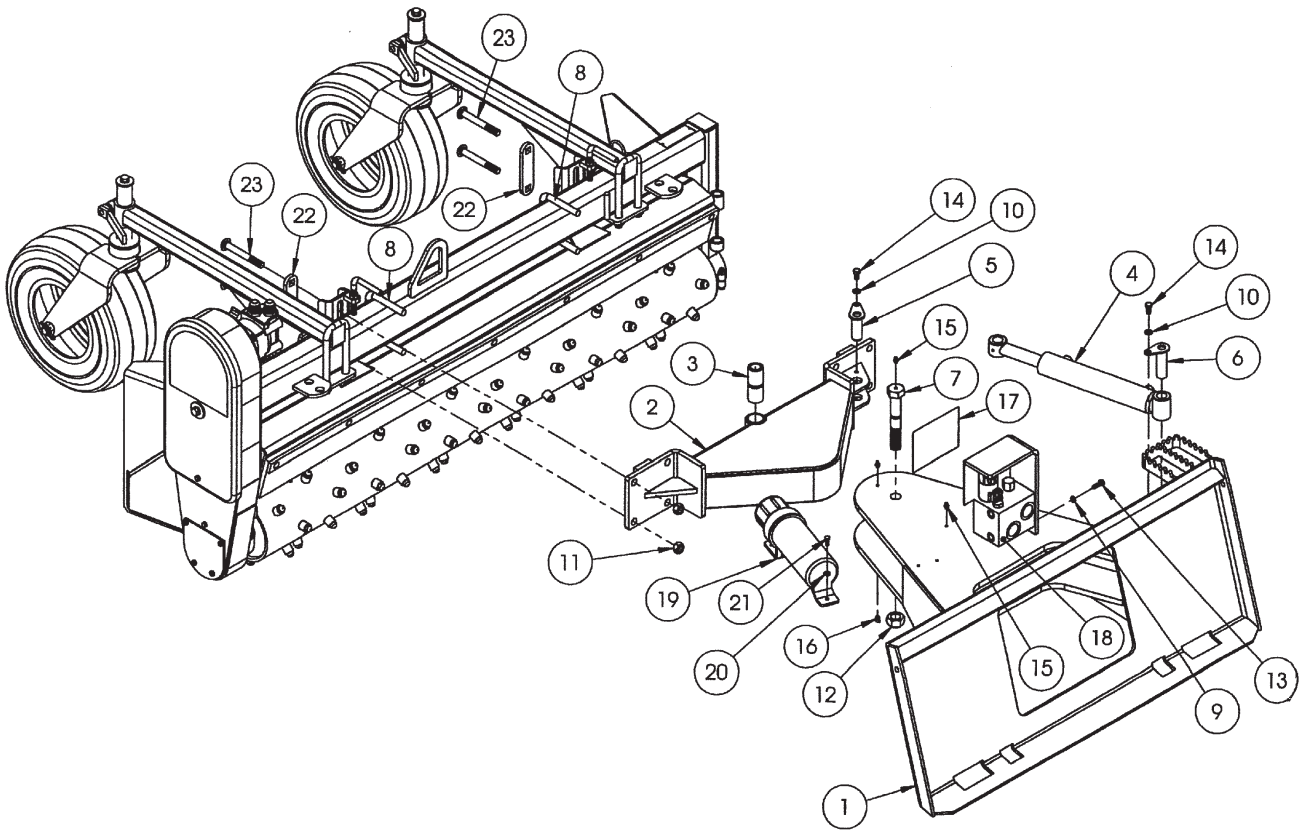

Figure 11. Hydraulic Angle Assembly

ASSEMBLY - ANGLING MODEL PARTS LIST

<u>ITEM</u>	<u>QTY</u>	<u>PART NO.</u>	<u>DESCRIPTION</u>
1	1	M16161PG	Attachment Mount
2	1	M16037PG	Pivot Mount
3	1	M18044	Pivot Bushing
4	1	P257600	Hydraulic Cylinder
5	1	M18039	2-5/8" Lock Pin
6	1	M25065	3-7/16" Lock Pin
7	1	M18040	6-1/2" Pivot Bolt
8	2	P128440	5/8" X 4" X 4-1/4" U-Bolt
9	3	P851105	5/16" Lock Washer
10	2	P851106	3/8" Lock Washer
11	8	P157500	5/8"-11 Top Lock Nut
12	1	P156401	1" Fine Thread Top Lock Nut
13	3	P100504	5/16"-18 X 1" Hex Bolt
14	2	P100603	3/8"-16 X 3/4" Hex Bolt
15	4	P620600	1/4"-28 Straight Grease Fitting
16	1	P620000	1/4"-28 X 45° Grease Fitting
17	1	P970250	Decal: Danger Roller
18	1	P243506	50 GPM Hydraulic Manifold
19	1	P136000	Manual Tube
20	3	P850104	1/4" Flat Washer
21	3	P102403	1/4"-28 X 3/4" Fine Thread Hex Bolt
22	2	M15040PG	Carriage Bolt Strap
23	4	P104920	5/8"-11 X 5" Carriage Bolt

ASSEMBLY - MANUAL ANGLE

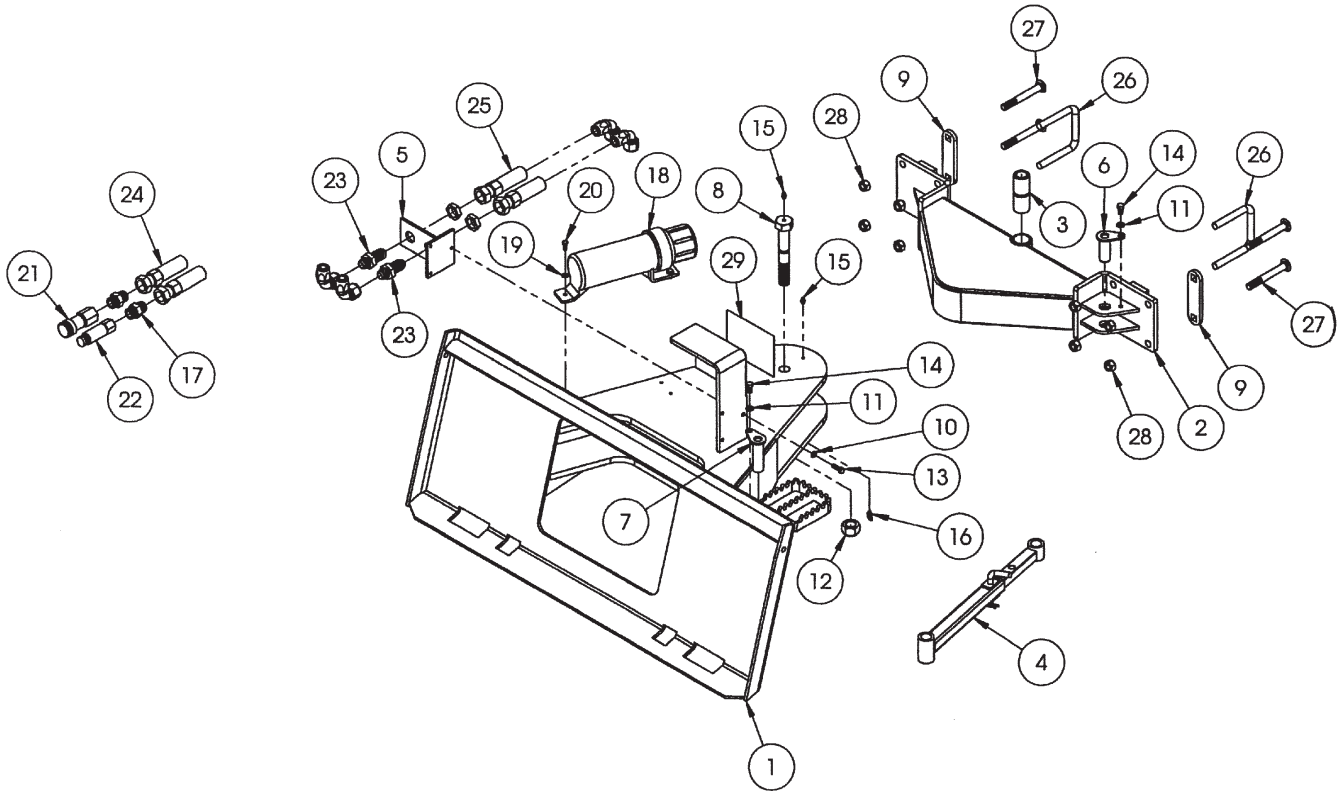

Figure 12. Manual Angle Assembly

ASSEMBLY - MANUAL ANGLE PARTS LIST

<u>ITEM</u>	<u>QTY</u>	<u>PART NO.</u>	<u>DESCRIPTION</u>
1	1	M16161PG	Attachment Mount
2	1	M16037PG	Pivot Mount
3	1	M18044	Pivot Bushing
4	1	M16074	Adjustment Bar Assembly
5	1	M18139PG	3 Hole Bulk Head Mount
6	1	M18039	3" Lock Pin
7	1	M25065	3-7/16" Lock Pin
8	1	M18040	1"-14 X 6-1/2" Pivot Bolt
9	2	M15040PG	Carriage Bolt Strap
10	3	P851105	5/16" Lock Washer
11	2	P851106	3/8" Lock Washer
12	1	P156401	1"-14 Top Lock Nut
13	3	P100504	5/16"-18 X 1" Hex Bolt
14	2	P100603	3/8"-16 X 3/4" Hex Bolt
15	4	P620200	1/4"-28 Straight Grease Fitting
16	1	P620000	1/4"-28 Grease Fitting 45°
17	2	P276450	12MB-12MJ Straight
18	1	P136000	Manual Tube
19	3	P850104	1/4" Flat Washer
20	3	P102403	1/4"-28 X 3/4" Hex Bolt
21	1	P272670	Female Flat Face Coupler
22	1	P272671	Male Flat Face Coupler
23	2	P276650	-12 Bulkhead Fitting
24	2	P255737	-10 Hose X 68" 12FJX-12FJX90°
25	2	P255685	-10 Hose X 44" 12FJX-12FJX90°
26	2	P128440	5/8" X 4" X 4-1/2" U-Bolt
27	4	P104920	5/8"-11 X 5" Carriage Bolt
28	8	P157500	5/8"-11 Top Lock Nut
29	1	P970250	Decal: Danger Roller

ASSEMBLY - HYDRAULIC ANGLE FLOAT MODEL

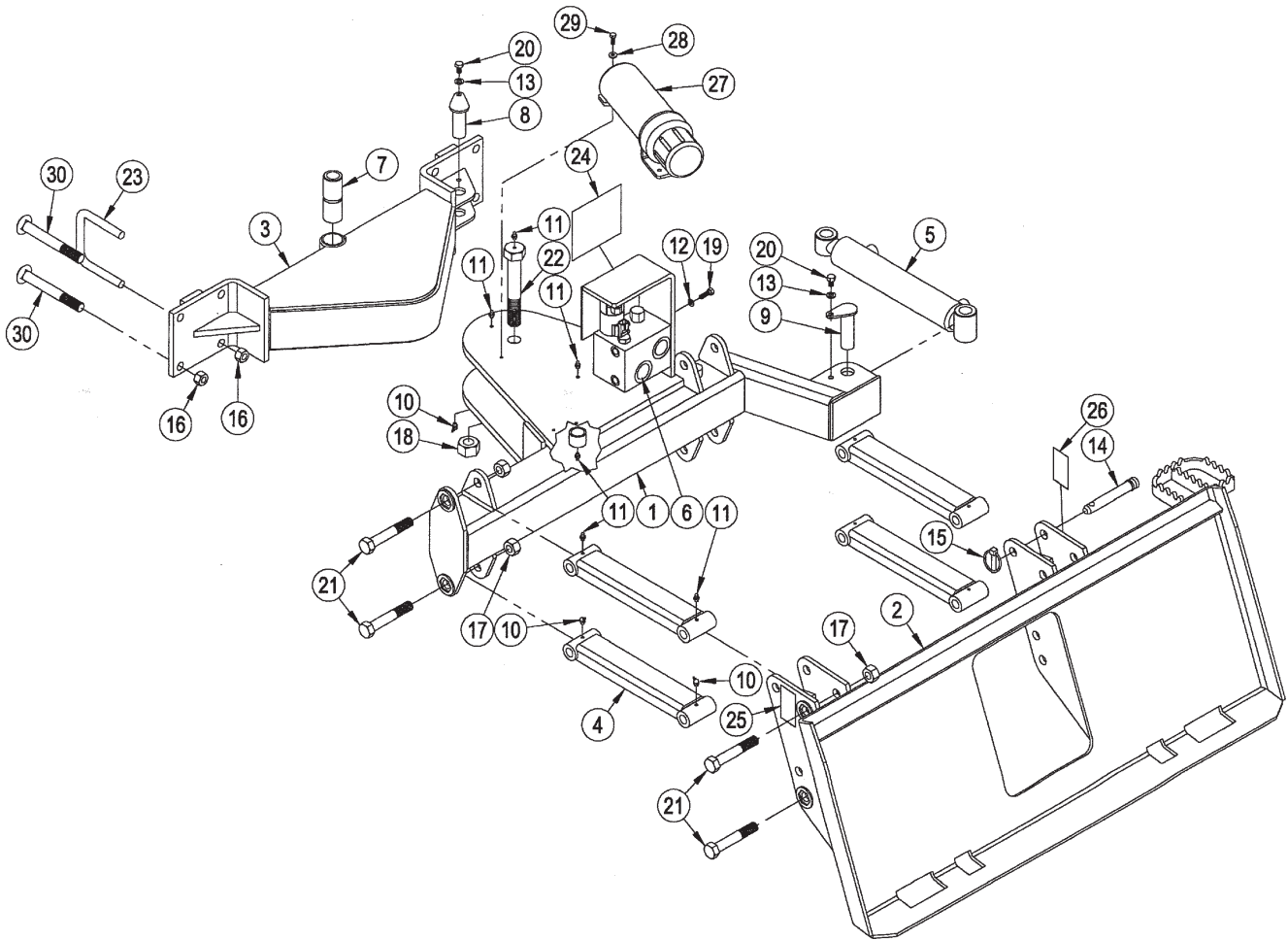

Figure 13. Hydraulic Angle Float Assembly

ASSEMBLY - HYDRAULIC ANGLE FLOAT MODEL PARTS LIST

<u>ITEM</u>	<u>QTY</u>	<u>PART NO.</u>	<u>DESCRIPTION</u>
1	1	M16160PG	Floating Pivot Mount
2	1	M16092PG	Attachment Plate
3	1	M16037PG	Pivot Mount
4	4	M6795PG	Link Arm
5	1	P257600	Hydraulic Cylinder
6	1	P243506	50 GPM Hydraulic Manifold
7	1	M18044	Pivot Bushing
8	1	M18039	2-5/8" Lock Pin
9	1	M25065	3-7/16" Lock Pin
10	5	P620000	1/4"-28 X 45° Grease Fitting
11	8	P620200	1/4"-28 Straight Grease Fitting
12	3	P851105	5/16" Lock Washer
13	2	P851106	3/8" Lock Washer
14	2	P120210	3/4" X 3-7/8" Clevis Pin
15	2	P126207	7/16" Lynch Pin
16	8	P157500	5/8" Top Lock Nut
17	8	P157120	3/4" Top Lock Nut
18	1	P156401	1" Fine Thread Lock Nut
19	3	P100504	5/16" X 1" Hex Bolt
20	2	P100603	3/8" X 3/4" Hex Bolt
21	8	M6816	3/4" X 4-1/2" Hex Bolt
22	1	M18040	6-1/2" Pivot Bolt
23	2	P128440	5/8" X 4" X 4-1/4" U-Bolt
24	1	P970250	Decal: Danger Roller
25	1	P970010	Decal: Lock-Out Left
26	1	P970011	Decal: Lock-Out Right
27	1	P136000	Manual Tube
28	3	P850104	1/4" Flat Washer
29	3	P102403	1/4"-28 X 3/4" Fine Thread Bolt
30	2	P104920	5/8"-11 X 5" Carriage Bolt

ASSEMBLY - ROLLER FRAME

DIAGRAM 1 OF 2

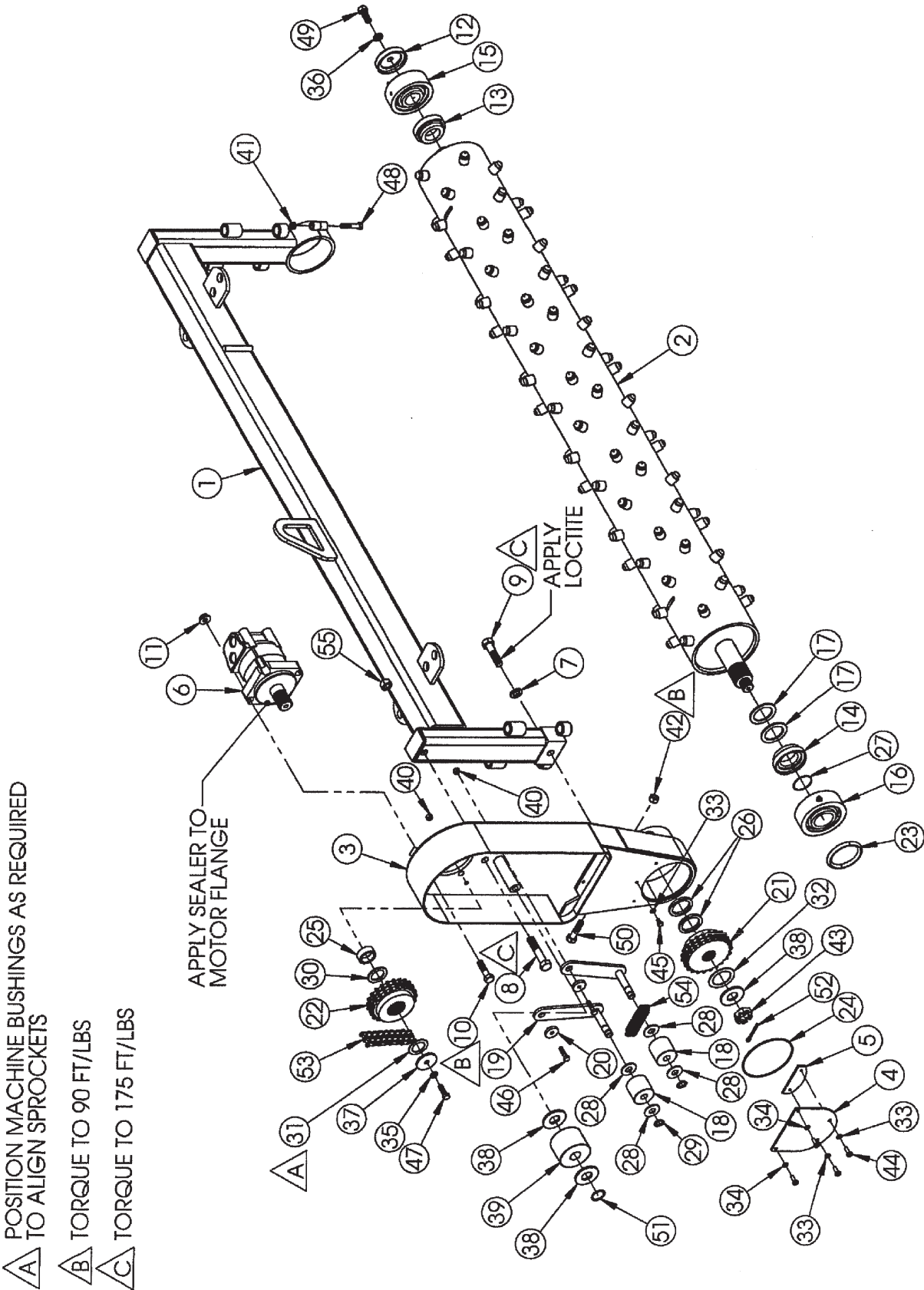

- A** POSITION MACHINE BUSHINGS AS REQUIRED TO ALIGN SPROCKETS
- B** TORQUE TO 90 FT/LBS
- C** TORQUE TO 175 FT/LBS

Figure 14. Roller Frame Assembly

ASSEMBLY - ROLLER FRAME PARTS LIST

LIST 1 OF 2

<u>ITEM</u>	<u>QTY</u>	<u>PART NO.</u>	<u>DESCRIPTION</u>
1	1	M15033PG	Main Frame Weldment
2	1	M15034PG	Carbide Tooth Roller
3	1	M8609PG	Chain Case
4	1	M8241PG	Lower Cover Assembly
5	1	M8272	Cover Tab
6	1	P350250	4000 Series Compact Motor
7	1	P851110	5/8" Lock Washer
8	1	P101013	5/8"-11 X 3-1/4" Hex Bolt
9	1	P101010	5/8"-11 X 2-1/2" Hex Bolt
10	4	P100808	1/2"-13 X 2" Hex Bolt GR8
11	4	P155851	1/2"-13 Top Lock Flange Nut GR8
12	1	P015307	1-1/2" Bearing Cap
13	1	P015308	1-1/2" Non-Locking Collar
14	1	P015309	1-3/4" Non-Locking Collar
15	1	M6573	Idler Bearing Assembly
-	-	P015210	1-1/2" Bearing Housing
-	-	P010401	1-1/2" Bearing Insert
16	1	M6574	1-3/4" Cylindrical Bearing Assembly
-	-	P015215	1-3/4" Bearing Housing
-	-	P012201	1-3/4" Bearing Insert
17	2	P855128	10 GA X 1-3/4" Machine Bushing
18	2	M6628	Idler Roller
19	2	M16113	Tension Arm
20	2	M6630	Pivot Bushing
21	1	P652200	Drive Spocket 1-1/4"-22T
22	1	P652201	Sprocket 50-2, 22 Tooth 1-3/4" Spline
23	1	P500203	3/8" X 2-5/8" O-Ring
24	1	P500202	3/32" X 4-3/4" O-Ring
25	1	M8637	Collar
26	2	M16056	.218" X 1-3/4" X 2-1/4" Spacer
27	1	P500175	1/16" X 1-3/4" ID O-Ring
28	4	P850609	9/16" Flat Washer
29	2	P952224	5/8" Heavy Snap Ring
30	1	P855120	10 GA X 1-1/4" Machine Bushing
31	1	P855320	14 GA X 1-1/4" Machine Bushing
32	1	P855328	14 GA X 1-3/4" Machine Bushing
33	3	P500300	1/4" Sealing Washer
34	2	P851104	1/4" Lock Washer
35	1	P851106	3/8" Lock Washer
36	1	P851108	1/2" Lock Washer

ASSEMBLY - ROLLER FRAME

DIAGRAM 2 OF 2

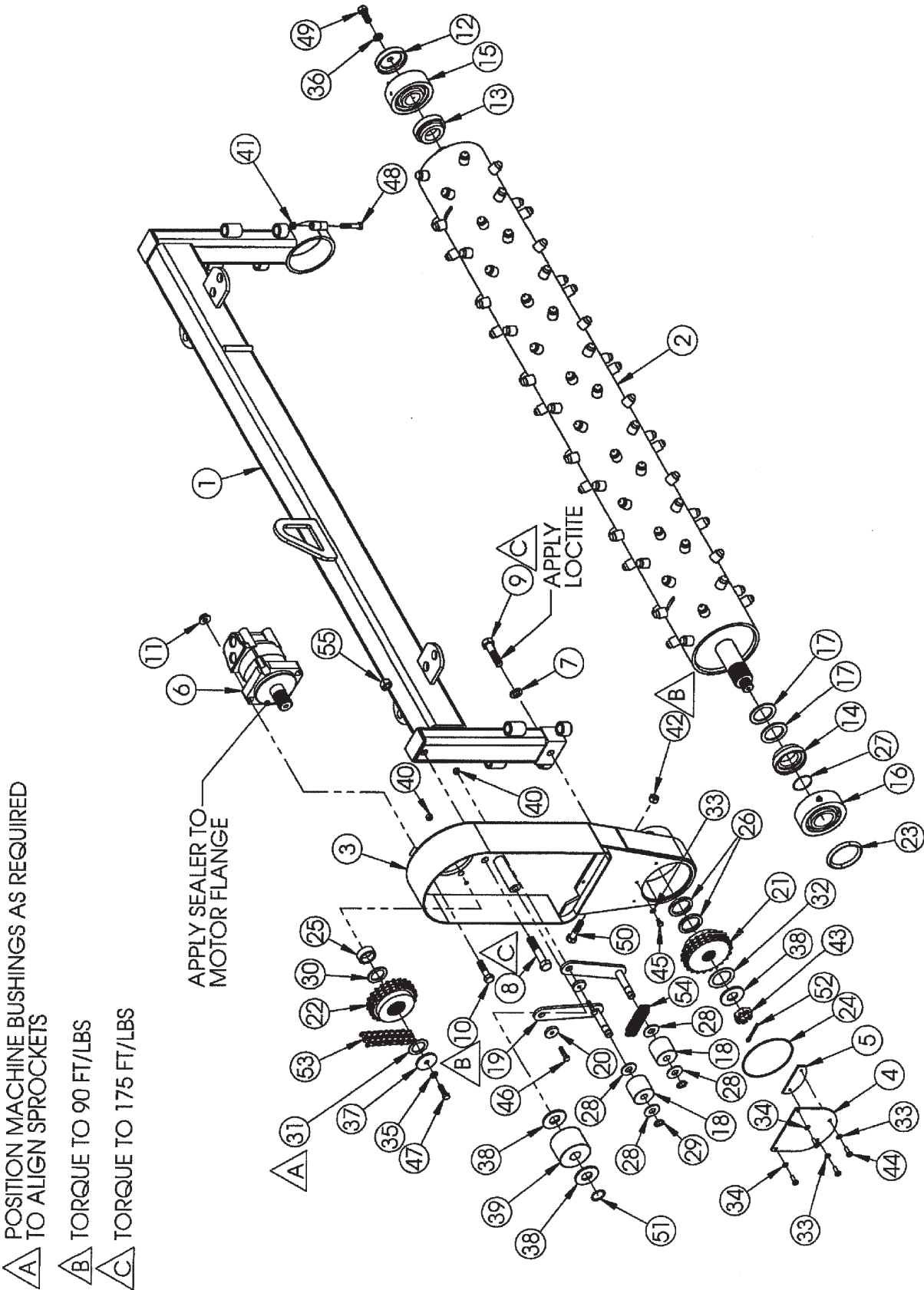

Figure 14. Roller Frame Assembly

ASSEMBLY - ROLLER FRAME PARTS LIST

LIST 2 OF 2

<u>ITEM</u>	<u>QTY</u>	<u>PART NO.</u>	<u>DESCRIPTION</u>
37	1	M14038	3/8" X 2" OD Washer
38	3	M5464	1" ID X 2-1/4" OD Washer
39	1	M6568	Chain Idler
40	2	P155350	5/16"-18 Top Lock Nut
41	1	P155450	3/8"-16 Top Lock Nut
42	1	P155852	1/2"-20 Top Lock Nut
43	1	P156402	1"-14 Slotted Hex Jam Nut
44	4	P110901	1/4"-20 X 3/4" Button Head Screw
45	1	P100402	1/4"-20 X 1/2" Hex Bolt
46	2	P100505	5/16"-18 X 1-1/4" Hex Bolt
47	1	P100605	3/8"-16 X 1-1/4" Hex Bolt
48	1	P100608	3/8"-16 X 2" Hex Bolt
49	1	P102805	1/2"-20 X 1-1/4" Fine Thread Hex Bolt
50	1	P102808	1/2"-20 X 2" Fine Thread Hex Bolt
51	1	P952260	1" Rotor Clip Ring
52	1	P116306	3/16" X 1-1/2" Cotter Pin
53	1	M8636	Roller Chain 50-2 93P W/Conn
54	1	P604800	Extension Spring
55	1	P157500	5/8"-11 Top Lock Nut

ASSEMBLY - MAIN

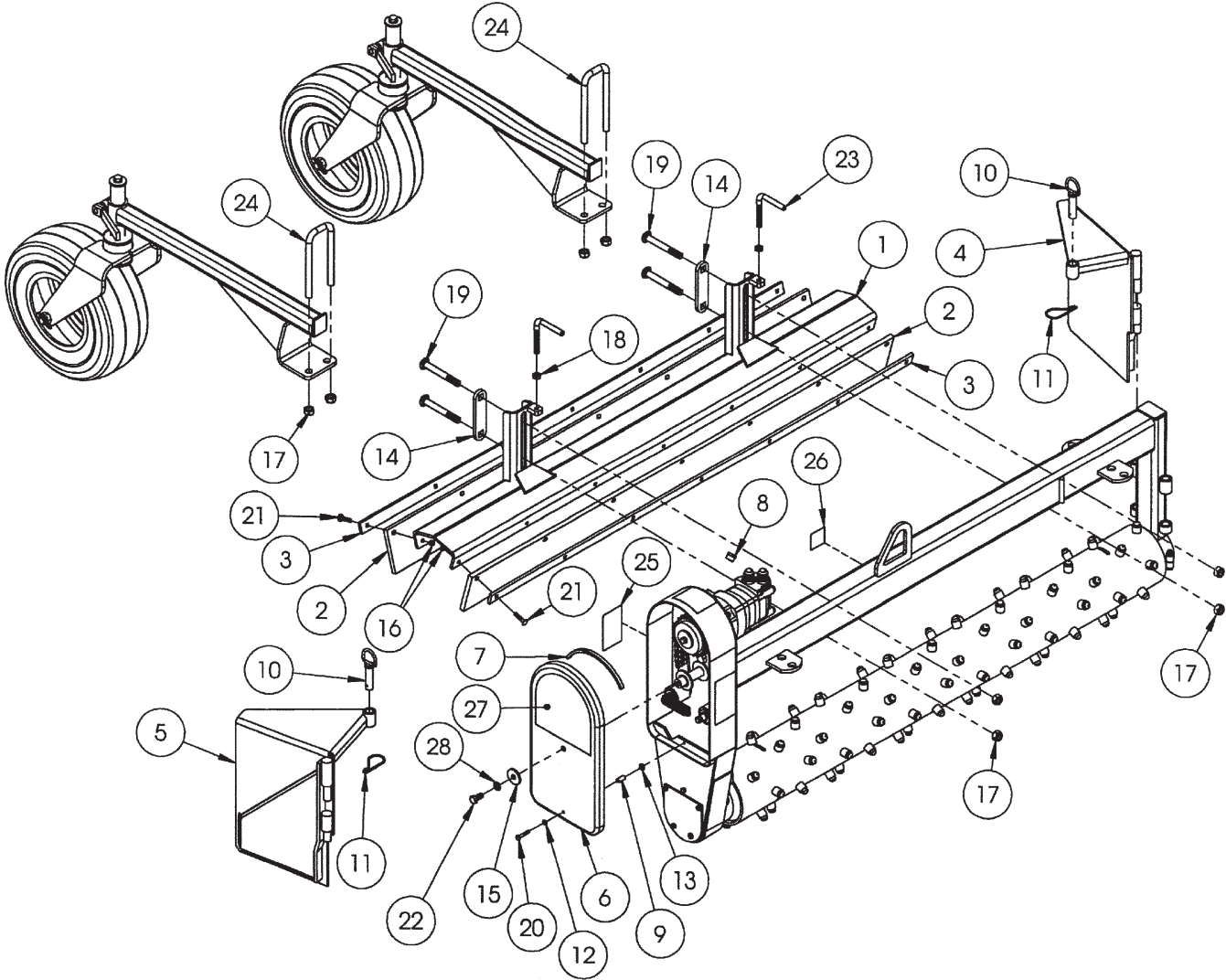

Figure 15. Main Assembly

ASSEMBLY - MAIN PART LIST

<u>ITEM</u>	<u>QTY</u>	<u>PART NO.</u>	<u>DESCRIPTION</u>
1	1	M15036PG	Barrier Mount
2	2	M15038	Barrier
3	2	M15039PG	Barrier Strap
4	1	M6624PG	Right End Plate
5	1	M6625PG	Left End Plate
6	1	M8624PG	Chain Case Cover
7	1	M8626	Cover Seal
8	1	P278001	Breather Plug
9	1	P481010	Bushing Spacer
10	2	M6442	Gate Pin
11	2	P622600	Hair Pin Clip
12	1	P500300	1/4" Sealing Washer
13	1	P500302	1/4" Rubber Face Washer
14	2	M15040PG	Carriage Bolt Strap
15	1	M5009-5	3/16" THK X 1/2" ID X 1-3/4" OD Washer
16	14	P155350	5/16"-18 Top Lock Nut
17	8	P157500	5/8"-11 Top Lock Nut
18	2	P157200	1/2"-13 Hex Jam Nut
19	4	P104920	5/8"-11 X 5" Carriage Bolt
20	1	P100406	1/4"-20 X 1-1/2" Hex Bolt
21	14	P104506	5/16"-18 X 1-1/2" Carriage Bolt
22	1	P100804	1/2"-13 X 1" Hex Bolt
23	2	P127110	1/2"-13 L-Bolt
24	2	P128410	5/8"-11 X 2" X 7-1/4" U-Bolt
25	1	P970003	Decal: Lubrication
26	1	P976500	Decal: Lift Hook
27	1	P975936	Decal: Chain Case Cover
28	1	P851108	1/2"-13 Lock Washer

ASSEMBLY - CASTER WHEEL

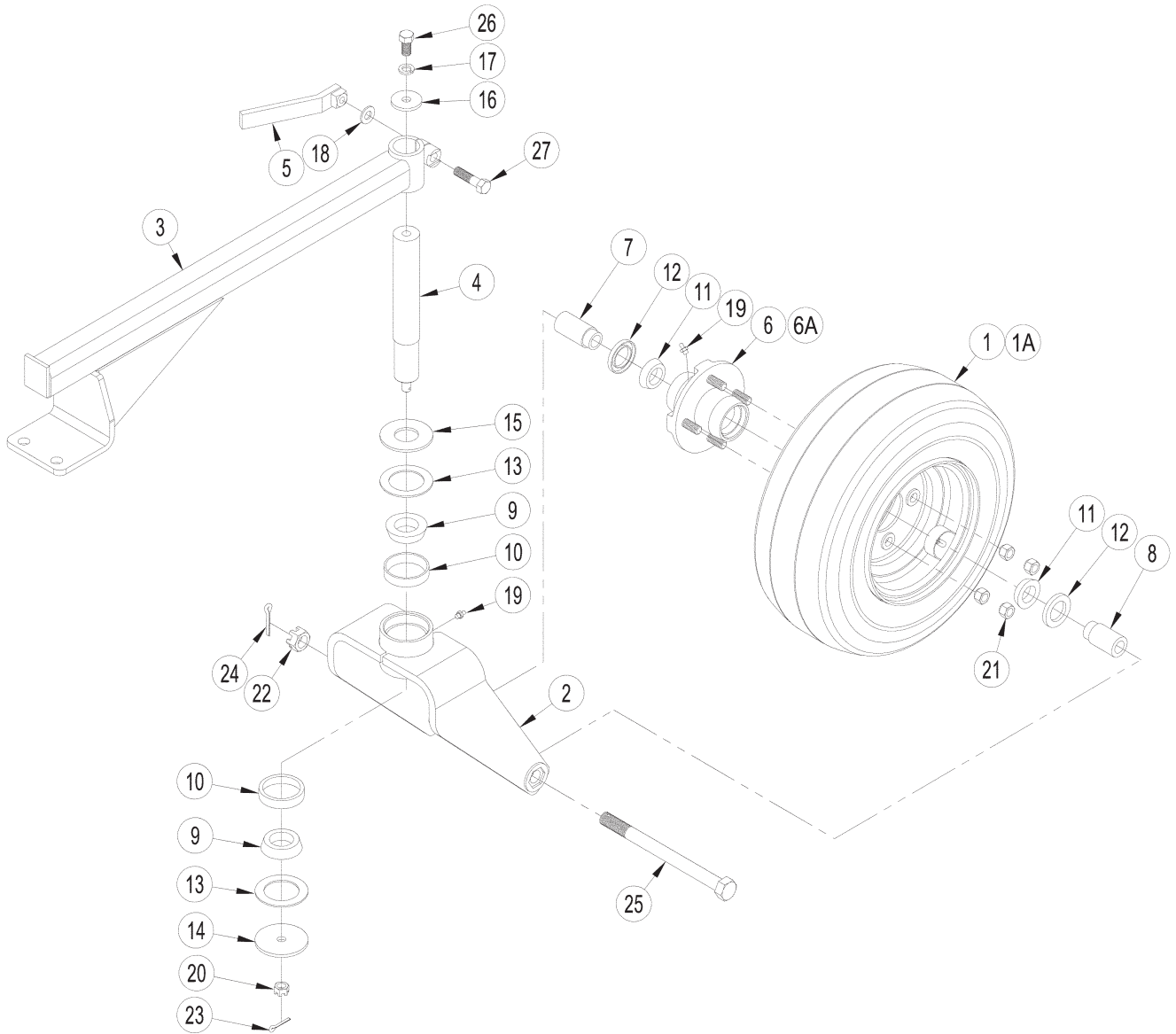

Figure 16. Caster Wheel Assembly

ASSEMBLY - CASTER WHEEL PARTS LIST

<u>ITEM</u>	<u>QTY</u>	<u>PART NO.</u>	<u>DESCRIPTION</u>
1	1	P756160	Wheel & Tire
1A	1	M16107	Wheel, Tire, & Hub
2	1	M6817PG	Caster Fork
3	1	M16153PG	Caster Support Arm
4	1	M16011	Caster Shaft
5	1	M6415PG	Handle
6	1	M16158	Wheel Hub W/Studs
6A	1	M16120	Wheel Hub Complete
7	1	M16108	Axle Spacer Long
8	1	M16109	Axle Spacer Short
9	2	P760300	Bearing Cone
10	2	P760500	Bearing Cup
11	2	P762200	1" Bearing Cone
12	2	P756163	Grease Seal
13	2	P852200	Felt Washer
14	1	M6223	3/16" X 1/2" X 3" Washer
15	1	P850620	1-1/4" Flat Washer
16	1	M5009-5	3/16" X 1/2" X 1-3/4" Washer
17	1	P851108	1/2" Lock Washer
18	1	P852608	1/2" Hard Washer
19	2	P620200	1/4"-28 Straight Grease Fitting
20	1	P158006	1/2"-13 Slotted Hex Nut
21	4	P756165	1/2"-20 Wheel Nut
22	1	P158000	3/4"-16 Slotted Hex Nut
23	1	P116204	1/8" X 1" Cotter Pin
24	1	P116256	5/32" X 1-1/2" Cotter Pin
25	1	M10463	3/4" X 9-1/2" Axle Bolt
26	1	P100804	1/2" X 1" Hex Bolt
27	1	P102808	1/2" X 2" Fine Thread Hex Bolt

ASSEMBLY - ANGLE HYDRAULICS

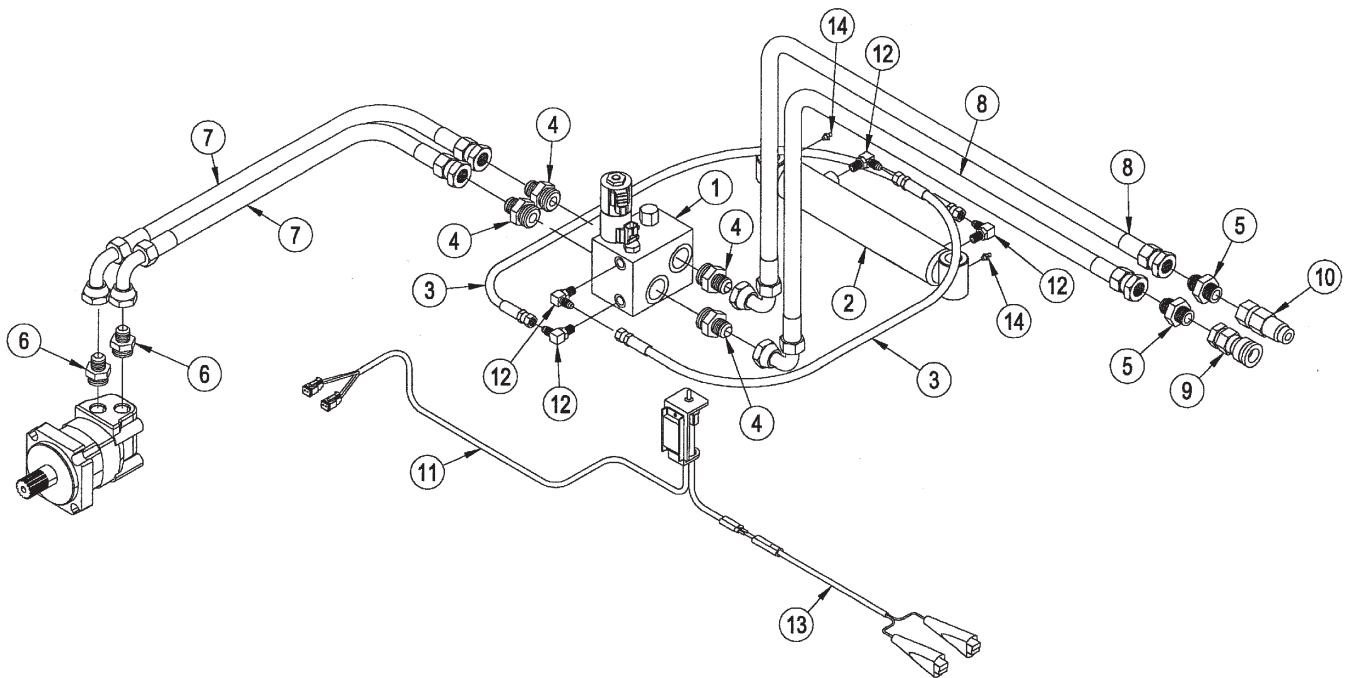
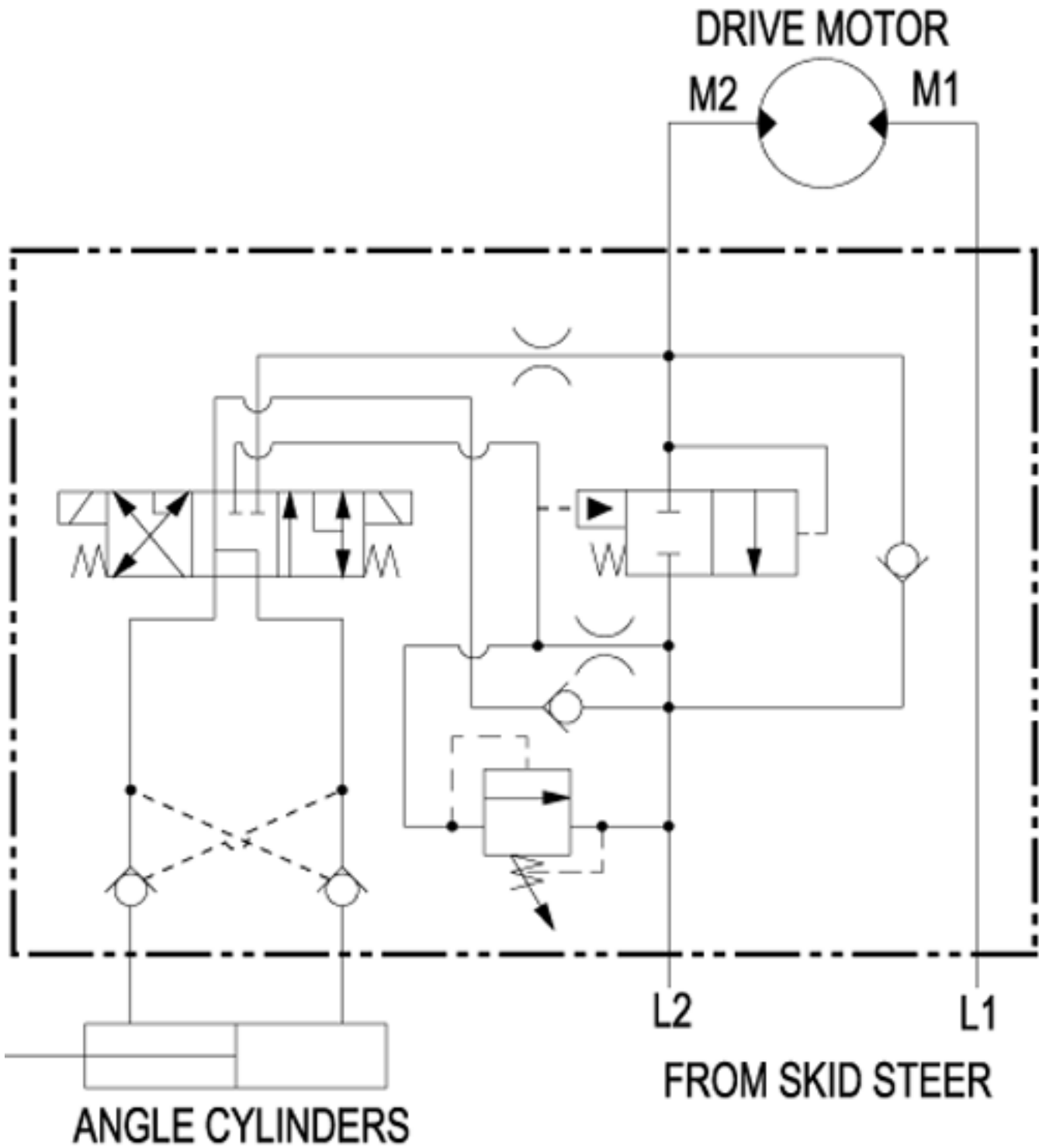

Figure 17. Angle Hydraulics Assembly

ASSEMBLY - ANGLE HYDRAULICS PARTS LIST

<u>ITEM</u>	<u>QTY</u>	<u>PART NO.</u>	<u>DESCRIPTION</u>
1	1	P243506	50 GPM Hydraulic Manifold
1A	1	P243501	Solenoid Cartridge
1B	2	P243505	Solenoid Coil
2	1	P257600	2" X 8" Hydraulic Cylinder
3	2	P246135	-4 Hose X 34" 6FJX-6FJX
4	4	P277100	Adapter 16MB-12MJ
5	2	P276450	Adapter 12MJ-12MB
6	2	P276440	Adapter 10MB-12MJ
7	2	P255685	-10 Hose X 44" 12FJX-12FJX90°
8	2	P255737	-10 Hose X 68" 12FJX-12FJX90°
9	1	P272670	Female Flat Face Coupler
10	1	P272671	Male Flat Face Coupler
11	1	M16159	Switch Assembly
12	4	P261350	Elbow 6MB-6MJ90°
13	1	M6726	Cable Assembly
14	2	P620200	1/4"-28 Straight Grease Fitting

HYDRAULIC SCHEMATIC



Limited Warranty

Except for the Excluded Products as described below, all new products are warranted to be free from defects in material and/or workmanship during the Warranty Period, in accordance with and subject to the terms and conditions of this Limited Warranty.

1. Excluded Products. The following products are excluded from this Limited Warranty:

(a) Any cable, part that engages with the ground (i.e. sprockets), digging chain, bearing, teeth, tamping and/or demolition head, blade cutting edge, pilot bit, auger teeth and broom brush that either constitutes or is part of a product.

(b) Any product, merchandise or component that, in the opinion of Paladin Light Construction¹, has been (i) misused; (ii) modified in any unauthorized manner; (iii) altered; (iv) damaged; (v) involved in an accident; or (vi) repaired using parts not obtained through Paladin Light Construction.

2. Warranty Period. The Limited Warranty is provided only to those defects that occur during the Warranty Period, which is the period that begins on the first to occur of: (i) the date of initial purchase by an end-user, (ii) the date the product is first leased or rented, or (iii) the date that is six (6) months after the date of shipment by Paladin Light Construction as evidenced by the invoiced shipment date (the "Commencement Date") and ends on the date that is twelve (12) months after the Commencement Date.

3. Terms and Conditions of Limited Warranty. The following terms and conditions apply to the Limited Warranty hereby provided:

(a) Option to Repair or Replace. Paladin Light Construction shall have the option to repair or replace the product.

(b) Timely Repair and Notice. In order to obtain the Limited Warranty, (i) the product must be repaired within thirty (30) days from the date of failure, and (ii) a claim under the warranty must be submitted to Paladin Light Construction in writing within thirty (30) days from the date of repair.

(c) Return of Defective Part or Product. If requested by Paladin Light Construction, the alleged defective part or product shall be shipped to Paladin Light Construction at its manufacturing facility or other location specified by Paladin Light Construction, with freight PRE-PAID by the claimant, to allow Paladin Light Construction to inspect the part or product.

Claims that fail to comply with any of the above terms and conditions shall be denied.

LIMITATIONS AND EXCLUSIONS.

THIS LIMITED WARRANTY IS IN LIEU OF ALL OTHER WARRANTIES, EXPRESS OR IMPLIED, INCLUDING WITHOUT LIMITATION THE WARRANTIES OF MERCHANTABILITY, FITNESS FOR A PARTICULAR PURPOSE AND ANY WARRANTY BASED ON A COURSE OF DEALING OR USAGE OF TRADE.

IN NO EVENT SHALL PALADIN LIGHT CONSTRUCTION BE LIABLE FOR CONSEQUENTIAL OR SPECIAL DAMAGES.

IN NO EVENT SHALL PALADIN LIGHT CONSTRUCTION BE LIABLE FOR ANY LOSS OR CLAIM IN AN AMOUNT IN EXCESS OF THE PURCHASE PRICE, OR, AT THE OPTION OF PALADIN LIGHT CONSTRUCTION, THE REPAIR OR REPLACEMENT, OF THE PARTICULAR PRODUCT ON WHICH ANY CLAIM OF LOSS OR DAMAGE IS BASED. THIS LIMITATION OF LIABILITY APPLIES IRRESPECTIVE OF WHETHER THE CLAIM IS BASED ON BREACH OF CONTRACT, BREACH OF WARRANTY, NEGLIGENCE OR OTHER CAUSE AND WHETHER THE ALLEGED DEFECT IS DISCOVERABLE OR LATENT.

¹Attachment Technologies Inc., a subsidiary of Paladin Brands Holding, Inc. (PBHI) is referred to herein as Paladin Light Construction.

February 10, 2010



The Power of Combined Excellence