

Harley POWER BOX RAKE® MODEL S.6

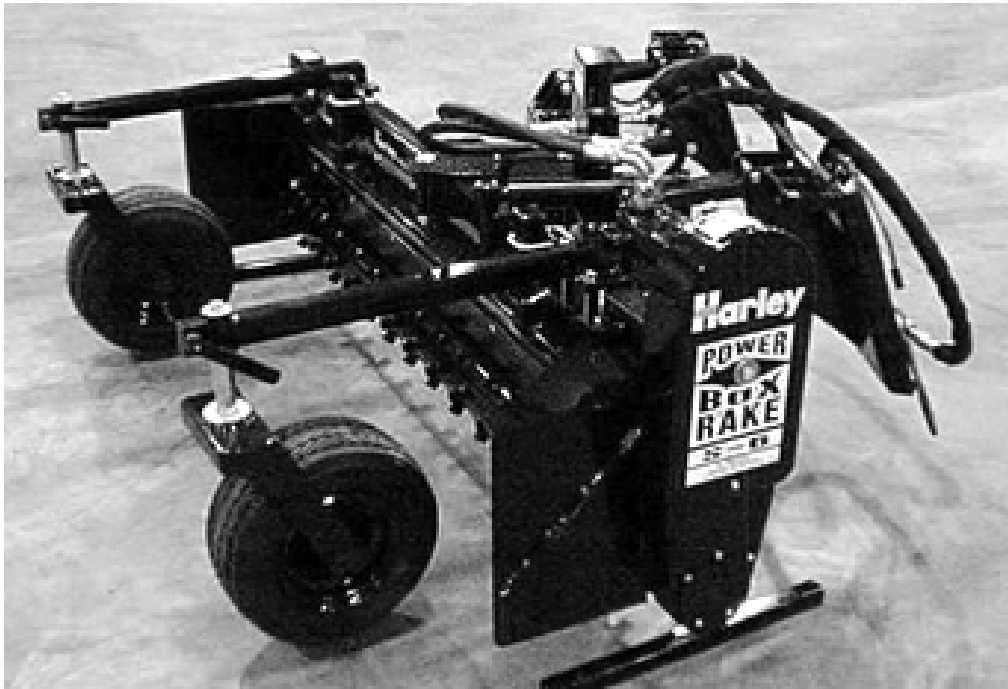

OPERATOR'S MANUAL

DATE PURCHASED

SERIAL NUMBER

PN-P970640 (02/2000)

Glenmac
INC

INTRODUCTION

GLENMAC, INC., based in Jamestown, North Dakota, along with your authorized Harley dealer, are proud that you chose to purchase a Harley Power Box Rake®. Equipment under the Harley name has been built and sold worldwide for over 35 years. GLENMAC, INC. specializes in the manufacturing of construction and landscape attachments designed to make your job more efficient, cleaner, and easier regardless of the complexity of the job. The Harley Power Box Rake® brings state-of-the-art design, ruggedness, and maneuverability to jobs such as: landscaping, seedbed preparation, site development, rock raking and picking, golf course construction, ball field renovation and maintenance, liner installation, horse track screening, sod farm ground work, beach cleaning - and the job for which you purchased your Harley.

This manual will provide you, the operator, with instructions for proper safety, assembly, and operation procedures so you can benefit from the equipment's optimum level of performance. Successful operation and long-life of your Harley Power Box Rake® depends on you. As owner and operator of your new Harley, it is your responsibility to become familiar with the proper operation and care required to operate it safely and efficiently and to maintain the equipment in top condition.

To keep your Harley equipment at peak performance, please READ THIS MANUAL CAREFULLY several times and follow the directions as specified for each operation. Correct operation and maintenance will save you time and expense.

REMINDER: Fill in the warranty card and mail within 10 days of your purchase date. While filling in the card with the correct information, put the date purchased and serial number on the front cover of this manual. Should you need to call your dealer or GLENMAC, INC., this information will help them to more quickly provide accurate service for you.

Thank you for purchasing a Harley Power Box Rake®.

For more information, contact your local Harley dealer or call:

GLENMAC INC.
PO Box 2135
Jamestown, North Dakota 58402-2135 U.S.A.

800/437-9779
701/252-9300
FAX 701/252-1978
Email: sales@glenmac.com



This Safety-Alert Symbol indicates a hazard and means **ATTENTION! BECOME ALERT! YOUR SAFETY IS INVOLVED!**



DANGER

Indicates an imminently hazardous situation that, if not avoided, will result in death or serious injury.



WARNING

Indicates a potentially hazardous situation that, if not avoided, could result in death or serious injury, and includes hazards that are exposed when guards are removed.



CAUTION

Indicates a potentially hazardous situation that, if not avoided, may result in minor or moderate injury.

TABLE OF CONTENTS

Introduction	1
Specifications	2
Owner Assistance	3
General Information	4
Bolt Size Chart	4
Bolt Torque Chart	5-6
Safety Rules	6-9
Safety Decals	10-11
Operation	12-17
Maintenance	18-23
Trouble Shooting	20
Assembly	24-30
Parts Identification and Drawings	28-31
Warranty	32

SPECIFICATIONS

Raking Width	72 Inches
Roller Type	Tooth Roller Standard 8" Diameter
Roller Angle	20 Degrees Both Directions
Gap (Tube to Barrier)	1-1/8" - 2-1/2" Adjustable
Skid-steer Lift Capacity Requirement	SAE Lift Capacity 1,200 lbs
Skid-steer Hydraulic Requirement	11 GP @ 2200 psi (min.)
Tires	16.5 x 6.5 - 8
Tire Pressure	45 psi
Weight	890 lbs
Oil Capacity of Chain Case	Approximately 1.5 Pints

OWNER ASSISTANCE

GLENMAC, INC. and your authorized Harley Dealer want you to be completely satisfied with your investment. Sometimes, however, misunderstandings can occur. To resolve any problem that may occur, please follow the instructions below.

1. If you did not purchase your rake from an authorized Harley Dealer, go to number 2 below.
 - A. Contact the Service Manager of the dealership, explain the problem, and request assistance. If additional assistance is needed, your dealer has direct access to our home office.
 - B. If your problem has not been handled to your satisfaction, contact:

CUSTOMER SERVICE (8:00 am - 5:00 pm CT)
GLENMAC, INC.
PO BOX 2135
JAMESTOWN ND 58402-2135
701/252-9300
800/437-9779

- C. Please be prepared to provide the following information:

- Your name, address, and telephone number,
- Machine model and SERIAL NUMBER,
- Dealership name and address,
- Machine purchase date,
- Nature of problem.

Your problem will likely be resolved in the dealership using the dealer's facilities, equipment, and personnel. Therefore, it is important that your initial contact be with the dealer.

2. If you did not purchase your equipment from an authorized dealer, call GLENMAC, INC., (see "B" above). There may be a new dealer in your area since you purchased your Harley Power Box Rake®. If there is no dealer in your area, our Customer Services Department can and will help you obtain the parts and information you may need. Please be prepared to provide the information requested under "C" above.

GENERAL INFORMATION

The purpose of this manual is to assist you in operating and maintaining your Power Box Rake®. Read it carefully. It furnishes information and instructions that will help you achieve years of dependable performance. These instructions have been compiled from extensive field experience and engineering data. Some information may be general in nature due to unknown and varying operating conditions. However, through experience and these instructions, you should be able to develop procedures suitable to your particular situation.

The illustrations and data used in this manual were current at the time of printing, but due to possible inline production changes, your machine may vary slightly in detail. We reserve the right to redesign and change the machines as may be necessary without notification.

Throughout this manual, references are made to front, back, right and left directions. These are determined by sitting in the operator's seat of the skid-steer.

BOLT SIZE CHART

NOTE: Chart shows bolt thread sizes and corresponding head (wrench) sizes for standard SAE and Metric Bolts.

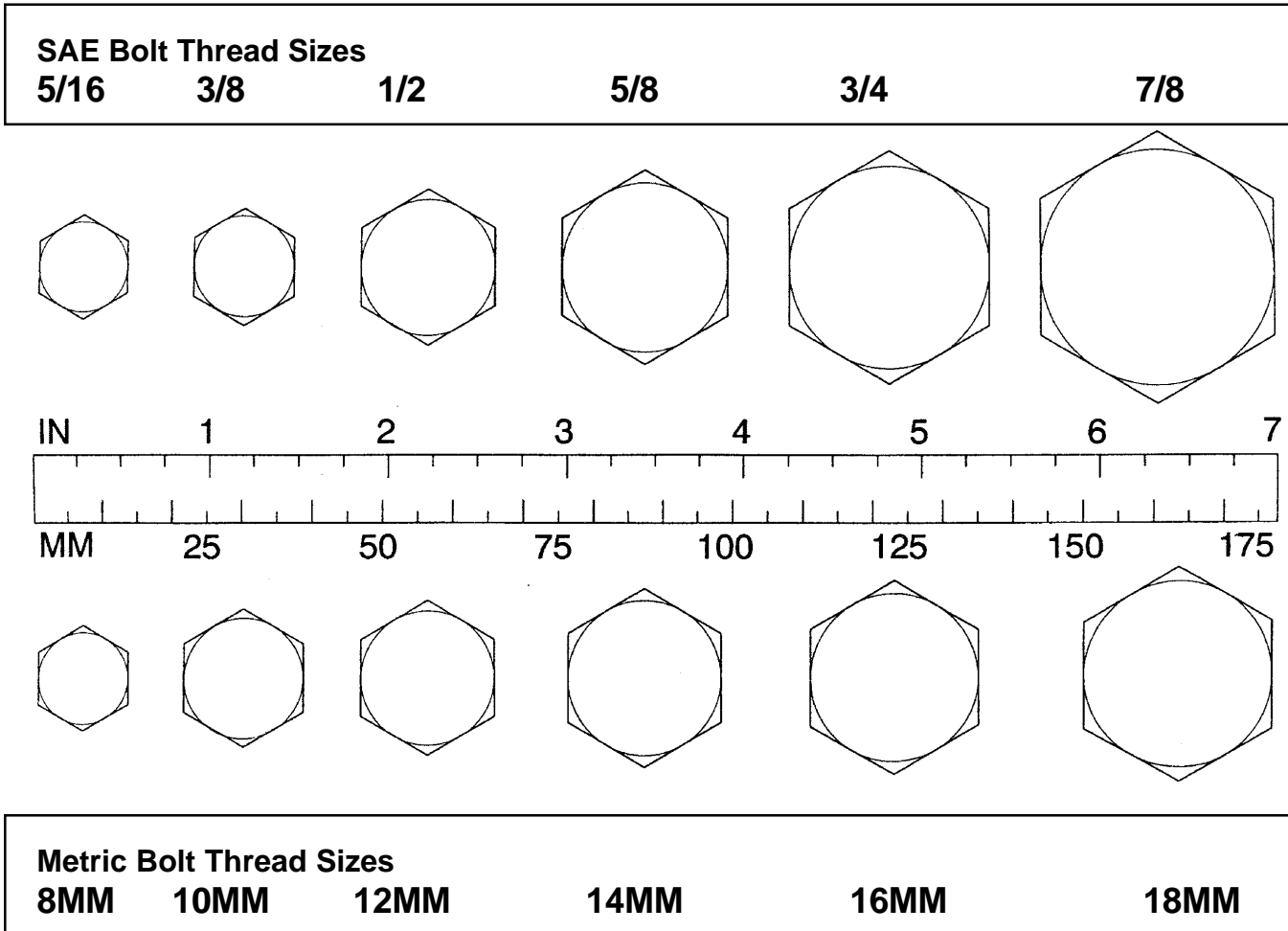

BOLT TORQUE CHART

After every ten (10) hours of operation, check all hardware and tighten where required.

SAE Series Torque Chart

DO NOT use these values if a different torque value or tightening procedure is listed for a specific application. Torque values listed are for general use only.

Fasteners should be replaced with the same grade.

Make sure fastener threads are clean and you properly start thread engagement. This will prevent them from failing when tightening.

SAE Bolt Head Identification



**SAE Grade 2
(No Dashes)**



**SAE Grade 5
(3 Radial Dashes)**



**SAE Grade 8
(6 Radial Dashes)**

Bolt Diameter "A"	Wrench Size	MARKING ON HEAD					
		SAE 2		SAE 5		SAE 8	
		Lbs.-Ft.	(N-m)	Lbs.-Ft.	(N-m)	Lbs.-Ft.	(N-m)
1/4"	7/16"	6	(8)	11	(15)	14	(19)
5/16"	1/2"	13	(18)	21	(28)	25	(34)
3/8"	9/16"	23	(31)	38	(52)	55	(75)
7/16"	5/8"	37	(50)	55	(75)	80	(110)
1/2"	3/4"	57	(77)	85	(115)	120	(165)
9/16"	13/16"	82	(111)	125	(170)	180	(245)
5/8"	15/16"	111	(150)	175	(240)	230	(310)
3/4"	1-1/8"	200	(270)	300	(410)	440	(600)
7/8"	1-5/16"	280	(380)	450	(610)	720	(975)
1"	1-1/2"	350	(475)	680	(925)	1035	(1400)
1-1/8"	1-11/16"	450	(610)	885	(1200)	<p>Bolt Diameter</p>	
1-1/4"	1-7/8"	600	(815)	1255	(1700)		
1-3/8"	2-1/16"	675	(915)	1620	(2200)		
1-1/2"	2-1/4"	920	(1250)	2200	(2900)		

BOLT TORQUE CHART

Metric Series Torque Chart

Use only metric tools on metric hardware. Other tools may not fit properly. They may slip and cause injury.

DO NOT use these values if a different torque value or tightening procedure is listed for a specific application. Torque values listed are for general use only.

Fasteners should be replaced with the same grade.

Make sure fastener threads are clean and you properly start thread engagement. This will prevent them from failing when tightening.

Bolt Diameter "A"	Wrench Size	MARKING ON HEAD			
		8.8		10.9	
		N-m	(Lbs.-Ft.)	N-m	(Lbs.-Ft.)
5 mm	8 mm	6	(4.5)	9	(6.5)
6 mm	10 mm	10	(7.5)	15	(11)
8 mm	13 mm	25	(18)	35	(26)
10 mm	16 mm	50	(37)	75	(55)
12 mm	18 mm	85	(63)	130	(97)
14 mm	21 mm	110	(80)	150	(110)
16 mm	24 mm	215	(159)	315	(232)
20 mm	30 mm	435	(321)	620	(457)
24 mm	36 mm	750	(553)	1070	(789)
30 mm	46 mm	1495	(1103)	2130	(1571)

Metric Bolt Head Identification

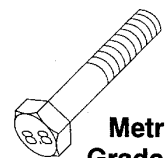

Metric Grade 8.8

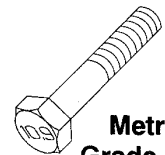

Metric Grade 10.9

After every ten (10) hours of operation, check all hardware and tighten where required.

SAFETY RULES



ATTENTION! BECOME ALERT! YOUR SAFETY IS INVOLVED!



Safety is a primary concern in the design and manufacture of our products. Unfortunately, our efforts to provide safe equipment can be wiped out by a single careless act of an operator. In addition to the design and configuration of equipment, hazard control and accident prevention are dependent upon the awareness, concern, prudence and proper training of personnel involved in the operation, transport, maintenance and storage of equipment. It has been said, "The best safety device is an informed, careful operator." We ask you to be that kind of operator.

The designed and tested safety of this equipment depends on it being operated within the limitations as explained in this manual.

TRAINING

- Safety instructions are important! Read all attachment and power unit manuals; follow all safety rules and safety decal information. (Replacement manuals are available from dealer or, in the United States and Canada, call 1-800-437-9779.) Failure to follow instructions or safety rules can result in serious injury or death.
- If you do not understand any part of this manual and need assistance, see your dealer.
- Know your controls and how to stop engine and attachment quickly in an emergency.
- Operators must be instructed in and be capable of the safe operation of the equipment, its attachments and all controls. Do not allow anyone to operate this equipment without proper instructions.

SAFETY RULES



ATTENTION! BECOME ALERT! YOUR SAFETY IS INVOLVED!



- Keep hands and body away from pressurized lines. Use paper or cardboard, not body parts to check for leaks. Wear safety goggles. Hydraulic fluid under pressure can easily penetrate skin and will cause serious injury or death.
- Make sure that all operating and service personnel know that in the event hydraulic fluid penetrates skin, it must be surgically removed as soon as possible by a doctor familiar with this form of injury, or gangrene, serious injury or death will result. **CONTACT A PHYSICIAN IMMEDIATELY IF FLUID ENTERS SKIN OR EYES. DO NOT DELAY.**
- Do not allow children or untrained persons to operate equipment.

PREPARATION

- Always check with your skid-steer manual or dealer for counter weight ballast that may be required for machine stability.
- Air in hydraulic systems can cause erratic operation and allows loads or equipment components to drop unexpectedly. Before operating or allowing anyone to approach the equipment, purge any air in the system by operating all hydraulic functions several times after connecting equipment, connecting hoses, or doing any hydraulic maintenance.
- After connecting hoses, check that all control lever positions function as instructed in the Operator's Manual. Do not operate until control lever and equipment movements are correct.
- Make sure all hydraulic hoses, fittings and valves are in good condition and not leaking before starting power unit or using equipment. Check and route hoses carefully to prevent damage. Hoses must not be twisted, bent sharply, kinked, frayed, pinched, or come into contact with any moving parts. Operate moveable components through full operational range to check clearances. Replace any damaged hoses immediately.
- Always wear relatively tight and belted clothing to avoid entanglement in moving parts. Wear sturdy, rough-soled work shoes and protective equipment for eyes, hair, hands, hearing and head.
- Ensure implement is properly attached, adjusted

and in good operating condition. Skid-steer coupler lock-pins must be fully extended and properly engaged into attachment retaining slots.

- Skid-steer must be equipped with ROPS and seat belt/operator restraint. Keep seatbelt/operator restraint securely fastened/engaged. Falling off skid-steer can result in death from being run over or crushed. Keep ROPS systems in place at all times.
- Ensure all safety decals are installed. Replace if damaged. (See **Safety Decals** section for location.)
- Ensure shields and guards are properly installed and in good condition. Replace if damaged.

OPERATIONAL SAFETY

- Improper operation can cause the machine to tip or roll over and cause injury or death.
 - Keep skid-steer lift arms and attachment as low as possible.
 - Do not travel or turn with skid-steer lift arms and attachment raised.
 - Turn on level ground.
 - Go up and down slopes, not across them.
 - Keep the heavy end of the machine uphill.
 - Do not overload the machine.
- Never use the skid-steer attachment to carry loads that exceed skid-steer rated operating capacity or other skid-steer specifications. Check your skid-steer manual or with your dealer for skid-steer rated operating capacity. Exceeding this capacity can cause machine to tip or roll over and cause injury or death.
- Use of a front safety door on the skid-steer is recommended for operation of the Power Box Rake®.
- Do not allow other people in the area when operating, attaching, removing, and assembling or servicing equipment.
- Only engage power when equipment is at ground operating level. Always disengage power when equipment is raised off the ground.
- Do not disconnect hydraulic lines until all system pressure is relieved. Lower unit to ground, stop engine, and operate all hydraulic control levers.
- Keep bystanders away from equipment while it is in operation.

SAFETY RULES



ATTENTION! BECOME ALERT! YOUR SAFETY IS INVOLVED!



- Never go underneath equipment lowered to the ground or raised. Never place any part of the body underneath equipment or between moveable parts even when the engine has been turned off. Hydraulic system leak down, hydraulic system failures, mechanical failures or movement of control levers can cause equipment to drop or rotate unexpectedly and cause severe injury or death.
- Service work does not require going underneath.
- Read Operator's Manual for service instructions or have done by a qualified dealer.
- Never direct discharge toward people, animals or property.
- Do not operate equipment while under the influence of alcohol or drugs.
- Operate only in the daylight or good artificial light.
- Keep hands, feet, hair and clothing away from equipment while engine is running. Stay clear of all moving parts.
- Always comply with all state and local lighting and marking requirements.
- Do not allow riders. Do not lift or carry anybody on the skid-steer or attachments.
- Always sit in skid-steer seat when operating controls or starting engine. Securely fasten seat belt/operator restraint, place transmission in park or neutral, engage brake and ensure all other controls are disengage before starting skid-steer engine.
- Look down and to the rear and make sure area is clear before operating in reverse.
- Use extreme care when working close to fences, ditches, other obstructions, or on hillsides.
- Do not operate on steep slopes.
- Do not stop, start or change directions suddenly on slopes.
- Use extreme care and reduce ground speed on slopes and rough terrain.
- Watch for hidden hazards on the terrain during operation.
- Stop skid-steer and implement immediately upon striking an obstruction. Dismount skid-steer using proper procedure. Inspect and repair any damage before resuming operation.

- Before leaving skid-steer operator's seat, follow skid-steer manual instructions. Lower skid-steer lift arms and put attachment on the ground. Stop engine, remove key, engage brake, and remove seat belt/operator restraint.

MAINTENANCE SAFETY

- Your dealer can supply original equipment hydraulic accessories and repair parts. Substitute parts may not meet original equipment specifications and may be dangerous.
- Always wear relatively tight and belted clothing to avoid entanglement in moving parts. Wear sturdy, rough-soled work shoes and protective equipment for eyes, hair, hands, hearing and head.
- Do not allow other people in the area when operating, attaching, removing, and assembling or servicing equipment.
- Never go underneath equipment lowered to the ground or raised. Never place any part of the body underneath equipment or between moveable parts even when the engine has been turned off. Hydraulic system leak down, hydraulic system failures, mechanical failures or movement of control levers can cause equipment to drop or rotate unexpectedly and cause severe injury or death. Service work does not require going underneath equipment. Read Operator's Manual for service instructions or have done by a qualified dealer.
- Avoid electrical system hazards. Never work on the electrical system unless you are qualified and thoroughly familiar with system details and the special handling requirements. Disconnect battery before working on electrical system. Remove "ground" cable first. When reconnecting battery, connect "ground" cable last.
- Ensure implement is properly attached, adjusted and in good operating condition. Skid-steer coupler lock-pins must be fully extended and properly engaged into attachment retaining slots.
- Never perform service or maintenance with engine running.
- Keep all persons away from operator control area while performing adjustments, service or maintenance.

SAFETY RULES



ATTENTION! BECOME ALERT! YOUR SAFETY IS INVOLVED!



- Tighten all bolts, nuts and screws, and check that all cotter pins are installed securely to ensure equipment is in a safe condition before operating.
- Ensure all safety decals are installed. Replace if damaged. (See **Safety Decals** section for location.)
- Ensure shields and guards are properly installed and in good condition. Replace if damaged.
- Before leaving skid-steer operator's seat, follow skid-steer manual instructions. Lower skid-steer lift arms and put attachment on the ground. Stop engine, remove key, engage brake, and remove seat belt/operator restraint.
- Do not disconnect hydraulic lines until all system pressure is relieved. Lower unit to ground, stop engine, and operate all hydraulic control levers.

Notes

STORAGE

- Follow manual instructions for storage.
 - Keep children and bystanders away from storage area.
-



Review the video included with your Rake for safety tips!

SAFETY DECALS



REPLACE IMMEDIATELY IF DAMAGED!



WARNING

Do not allow anyone to operate the Power Box Rake[®] or skid steer loader who has not been properly trained in its safe operation and has not read and understood the operator's manuals.

Before attaching, check skid steer loader lift capacity to insure its ability to safely handle the weight.

Do not operate without guards/shields in place and in good working order.

Stop all moving parts including skid steer loader engine before cleaning, unplugging, adjusting and/or performing maintenance.

Keep bystanders 10 feet from Power Box Rake[®] when in operation.

Failure to follow the above safety suggestions and those in the operator's manual can result in serious injury or death.

P970004

#1 - PN: P970004

DANGER



ROTATING PART HAZARD

- KEEP HANDS, HAIR AND CLOTHING AWAY FROM MOVING PARTS.
- CLOSE AND SECURE ALL SHIELDS BEFORE OPERATING.

FAILURE TO DO SO COULD RESULT IN SERIOUS INJURY OR DEATH

#2 - PN: P970300

DANGER

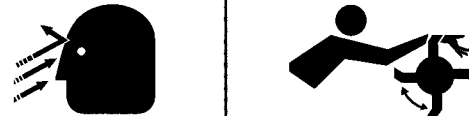

- Stay at least 9 feet (3m) away from operating equipment.
- Flying objects and rotating parts can cause injury or death.
- Stop engine before cleaning or servicing.
- Keep all guards in place.

P970250

#3 - PN: P970250

SAFETY DECALS



ATTENTION! BECOME ALERT! YOUR SAFETY IS INVOLVED!
REPLACE IMMEDIATELY IF DAMAGED!

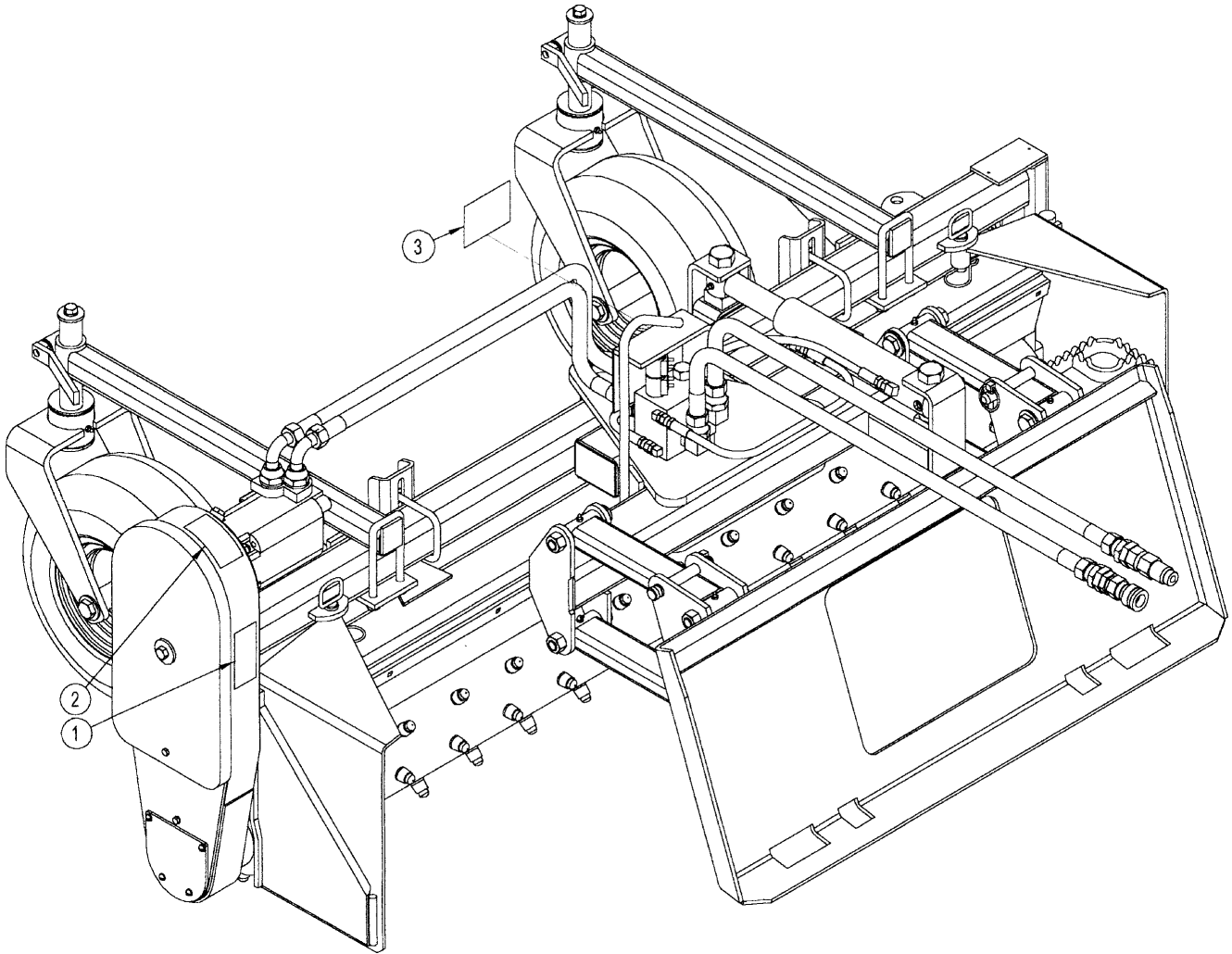

Figure 1. Safety Decals

OPERATION

Safety is a primary concern in the design and manufacture of our products. Unfortunately, our efforts to provide safe equipment can be wiped out by a single careless act of an operator.

In addition to the design and configuration of equipment, hazard control and accident prevention are dependent upon the awareness, concern, prudence, and proper training of personnel involved in the operation, transport, maintenance, and storage of equipment.

It has been said, *“The best safety device is an informed, careful operator.”* We ask you to be that kind of an operator.

The operator is responsible for the safe operation of this equipment. Operators must be instructed in and be capable of the safe operation of the equipment, its attachments, and all controls. Do not allow anyone to operate this equipment without proper instructions.

The S-6 Power Box Rake® is designed for removing rock and small debris, and for thatching. Skid-steers must be equipped with an auxiliary hydraulic system capable of supplying continuous flow for hydraulic motor operation. This manual contains information for the S-6 model. Refer to the information in this manual for specifications, parts, assemblies, and adjustments.



WARNING

- **Safety instructions are important! Read all attachment and power unit manuals; follow all safety rules and safety decal information. (Replacement manuals are available from dealer or, in the United States and Canada, call 1-800-437-9779.) Failure to follow instructions or safety rules can result in serious injury or death.**
- **Do not allow children or untrained persons to operate equipment.**
- **Skid-steer must be equipped with ROPS and seat belt/operator restraint. Keep seat belt/operator restraint securely fastened/engaged. Falling off skid-steer can result in death from being run over or crushed. Keep ROPS systems in place at all times.**
- **Do not allow other people in the area when operating, attaching, removing, assembling, or servicing equipment.**
- **Never go underneath equipment lowered to the ground or raised. Never place any part of the body underneath equipment or between moveable parts even when the engine has been turned off. Hydraulic system leak down, hydraulic system failures, mechanical failures, or movement of control levers can cause equipment to drop or rotate unexpectedly and cause severe injury or death.**

- **Service work does not require going underneath.**
- **Read Operator’s Manual for service instructions or have done by a qualified dealer.**
- **Before leaving skid-steer operator’s seat, follow skid-steer manual instructions. Lower skid-steer lift arms and put attachment on the ground. Stop engine, remove key, engage brake, and remove seat belt/operator restraint.**

ATTACHING POWER RAKE TO SKID-STEER

Read the skid-steer Operator’s Manual connecting and removing instruction.

Position hydraulic hoses so they will not be pinched when connecting the power rake.

The skid-steer coupler handles should be in the unlocked position and the lockpins retracted.

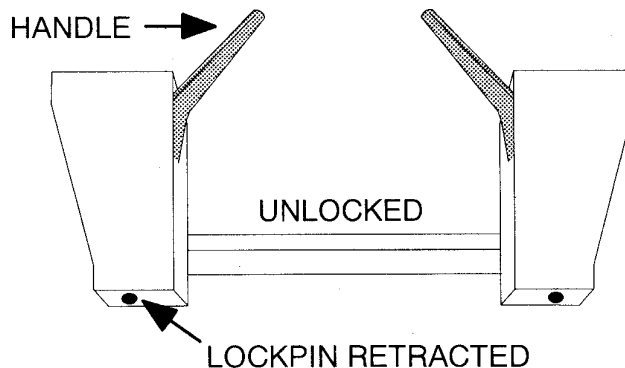

Figure 2. Skid-Steer Coupler Handles - Unlocked

Move to the skid-steer operator seat and start engine.

Lower skid-steer lift arms to their lowest position.

Carefully move and align the skid-steer to the power rake. The top of the skid-steer coupler must index into the power rake flange, **Figure 3.**

Roll the skid-steer coupler into the power rake so the coupler handles can be engaged.

OPERATION

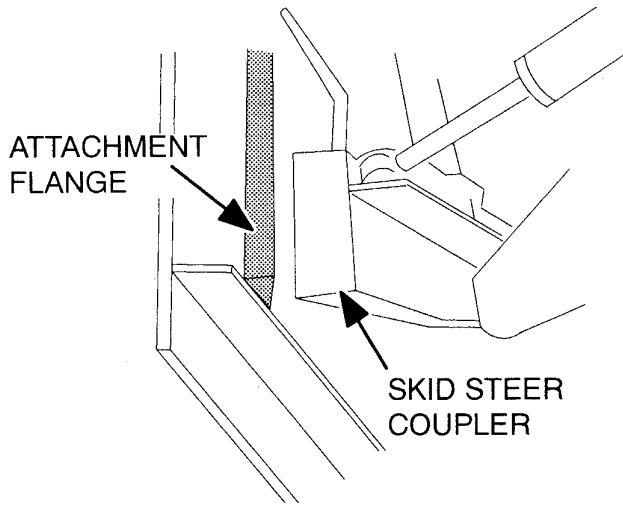

Figure 3. Attaching Power Rake to Skid-Steer

Shut off the engine, set brake, and remove key. Dismount the skid-steer.

Move the skid-steer coupler handles to the locked position. The lockpins must be completely extended and secured into the slots provided on the power rake, **Figure 4** and **Figure 5**.

Connect hydraulic hoses to skid-steer auxiliary quick couplers.

Mount the angle control switch in a convenient, easy-to-reach location. The switch bracket is magnetic and will attach to any flat steel surface. Connect the power cord to the cable coming from the switch. Be careful when routing the cable that sharp edges or moving parts will not damage the cable.

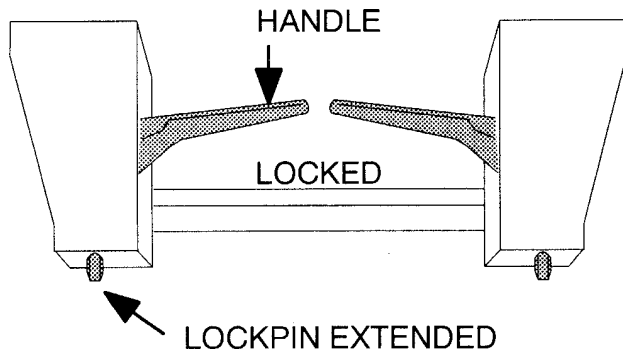

Figure 4. Skid-Steer Coupler Handles - Locked

Back View of Attachment

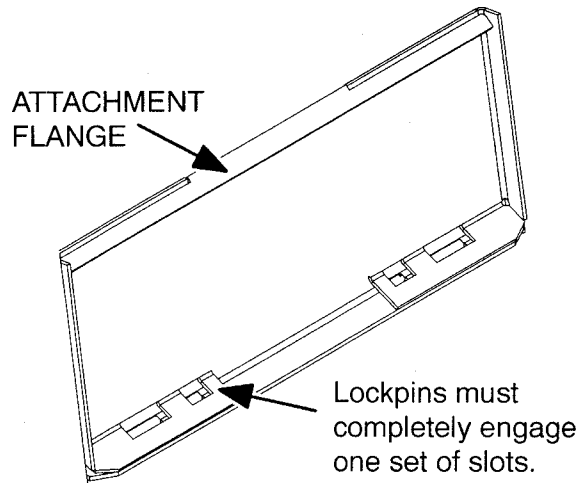

Figure 5. Back of Attachment - Slot Locations

POWER RAKE FUNCTION

The power rake hydraulic motor drives the roller, which digs into the ground, cultivating and pulling up rocks, roots, and debris.

The clean soil goes between the roller and barrier, while the rocks, roots, and debris work to the side in a windrow.

With the endplates mounted in the working position and the rake straight (endplates parallel with skid-steer tires), material can be moved along, filling in the low spots. Also, rocks, roots, and debris can be collected and moved to another location for hauling away.

PRE-OPERATION CHECK LIST (OWNER'S RESPONSIBILITY)

- ___ Review and follow all safety rules and safety decal instructions on pages 5 through 8.
- ___ Check that all safety decals are installed and in good condition. Replace if damaged.
- ___ Check that all shields and guards are properly installed and in good condition. Replace if damaged.
- ___ Check that all hardware and cotter pins are properly installed and secured.
- ___ Check that equipment is properly and securely attached to skid-steer.
- ___ Do not allow riders.
- ___ Check and keep all bystanders away from equipment working area.

OPERATION

- Check all lubrication points and grease as instructed in the **Maintenance** section starting on page 18.
- Check that all hydraulic hoses and fittings are in good condition and not leaking before starting skid-steer. Check that hoses are not twisted, bent sharply, kinked, frayed, or pulled tight. Replace any damaged hoses immediately.
- Make sure skid-steer ROPS and seat belt are in good condition. Keep seat belt securely fastened during operation.

OPERATING INSTRUCTIONS

Read and understand the power rake and skid-steer Operator's Manuals before operating the power rake. Failure to do so may result in death, serious personal injury, or property damage.

Never raise the power rake more than a few inches off the ground when traveling from job site to job site.

Shut off the engine, set brake, remove key, remove seat belt, and release operator restraint. Dismount the skid-steer.



WARNING

- **Improper operation can cause the machine to tip or roll over and cause injury or death.**
 - **Keep skid-steer lift arms and attachment as low as possible.**
 - **Do not travel or turn with skid-steer lift arms and attachment raised.**
 - **Turn on level ground.**
 - **Go up and down slopes, not across them.**
 - **Keep the heavy end of the machine uphill.**
 - **Do not overload the machine.**
- **Look down and to the rear and make sure area is clear before operating in reverse.**
- **Never direct discharge toward people, animals, or property.**
- **Only engage power when equipment is at ground operating level. Always disengage power when equipment is raised off the ground.**

Start-up Sequence



WARNING

- **Only engage power when equipment is at ground operating level. Always disengage power when equipment is raised off the ground.**

Start skid-steer engine.

Lower power rake slowly to the ground.

Engage hydraulic control lever for auxiliary implements.

Increase engine rpm to give desired rpm at the roller. Normal operating speed is approximately 270 rpm. If operating in heavy rock, reduce the speed slightly.

Move the skid-steer forward or backward as desired. For the roller to operate effectively, it must rotate in the opposite direction of the skid-steer wheels (see **Figure 6**). Roller rotation direction is controlled by skid-steer hydraulic controls.

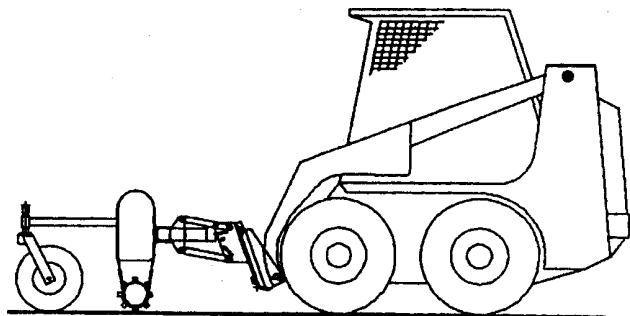



Roller Rotation	Travel Direction
	
	

Figure 6. Roller Rotation

Ground Speed

Ground speed should be between 3 and 5 mph under normal conditions. In heavy rock, reduce the ground speed to 1 to 3 mph.

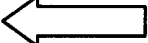
Direction Control Switch

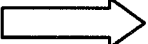
A three position switch is provided to angle the rake left or right. The switch is equipped with a magnetic mount and may be attached to a convenient steel surface near the operator. The direction valve uses a small amount of hydraulic oil bypassed from the roller drive motor and will only operate with the skid-steer auxiliary hydraulic system engaged and with the roller turning clockwise.

With the skid-steer auxiliary hydraulic system engaged, move the spring loaded switch in one direction and the

OPERATION

rake will angle left or right. Return the switch to center position and rake will maintain the angle selected.

Pivot rake to place the windrow left or right of the skid-steer.

Hydraulic Drive Motor

The hydraulic drive motor runs off the auxiliary circuit of the skid-steer. The power rake should be run at 30% power for one hour for proper motor break-in.

Power Roller

Roller should be level with the ground. The power rake should also be level with the ground front to back. To accomplish this, raise or lower gauge wheels and/or use the skid-steer's tilt cylinder.

To allow the roller to penetrate deeper into the ground, loosen the handle and raise the gauge wheels. To achieve the opposite, lower the gauge wheels.

The chain case end of roller weighs about 90 lbs. more than the other end of roller. To compensate for this, you should set the tire closest to the chain case down 1" lower than opposite tire. This will still give an even grade when landscaping and will prevent unusual or excess wear on the teeth on that end of the roller.

During operation, further depth control can be achieved by tilting the rake forward on gauge wheels to raise roller, or by tilting the rake back to raise gauge wheels and allow more roller penetration.

Be sure to check the air pressure in each tire regularly so that an even, consistent grade will be maintained.

The normal gap between the roller and barrier for average conditions is about 1-1/4". This gap can be adjusted either wider or narrower by loosening the U-bolt that holds the barrier mount and sliding it up or down. A wider opening will allow more dirt and rock to pass through. For finer raking, reduce the gap. (Be careful not to let roller hit barrier.) The gap should be the same all the way across. Barrier adjustment is shown in **Figure 7**.

The roller on the power rake is **bi-rotational**. You can operate the roller in both directions - clockwise and counter-clockwise. The roller operates most efficiently when it rotates in the opposite direction of the skid-steer wheels.

Operating Depth

When power raking, the depth will determine how much dirt is carried ahead of the roller. The ideal depth will vary with conditions and can be anywhere from skimming the surface to about 3" deep. See instructions in **Power Roller** above to set roller depth.

When making the first windrow, the level of dirt may be halfway up on the barrier. When moving the windrow two or three times, the level of the dirt may be to the top of the barrier. However, try to prevent material from flowing over the top.

The power rake allows fast raking of large areas of ground by being able to move windrows several times. Of course, the volume or density of the material being raked will dictate how many times a windrow can be moved.

Endplates

The function of the endplates is to contain the material in front of the roller while the clean material passes between the roller and barrier.

With the endplates mounted in the working position and the rake straight (parallel with skid-steer tires), material can be moved along, filling in the low spots.

By decreasing the gap between the roller and barrier, more material can be pulled along. Barrier adjustment is shown in **Figure 7**.

These plates can be mounted to the front or back of the power rake, depending on the raking direction. When you move the endplates from front to back, you must move the left one to the right side and the right one to the left side.

Make sure the disconnected power rake is stored on a hard, level surface. Use the endplates mounted on attachment side of rake to ensure stability.

Parallel Arms

The function of the parallel arms is to allow the power rake to "float" and follow the contour of the ground. Lock-out pins are supplied to allow more aggressive action. However, the hydraulic motor may stall out if too much down pressure is applied. See **Figure 7** for pin "float" and "lock-out" positions.

Operator Production

Successful operation of the power rake will come with operator experience. The rake's performance also depends on the type and size of the skid-steer it's mounted on.

An operator that masters the technique of adjusting the angle of attack of the roller against the soil will also find ideal settings under various conditions to give the desired results.

OPERATION

IMPORTANT

- **Do not drop power rake to the ground with the roller turning. Sudden high speed jolts multiply stress to the driveline and can cause extreme damage.**

Application Techniques

The power rake is capable of many applications. The following are some of the common applications:

Pulverizing Topsoil

For breaking up compacted soil or conditioning hardened baseball diamonds, the parallel arm locking pins are set in the “lock-out” position so that down pressure can be exerted on the tooth roller. The attachment plate is rolled back to take the guide wheels off the ground so only the toothed roller is in contact with the ground. Maintain sufficient rpm to avoid stalling the toothed roller in its progress. The rake can be straight or angled, but the endplates should not be mounted in order to allow material to move out of the way and not slow the process.

Debris Removal

Once the surface has been loosened, the process of removing debris can begin. The parallel arm locking pins are removed and stored in the “float” position holes. This allows the rake to begin the early stages of the final grading process. The skid-steer attachment plate is tilted forward until the guide wheels control the depth of the toothed roller. The rake can be angled at this time for windrowing debris or the rake can be set straight with both endplates installed to collect debris. Skid-steer travel speed should be increased for this process.

Finish Grading

For this operation, set the rake’s parallel arms in the “float” position and mount both endplates in the forward position. The rake is tilted forward until the teeth of the toothed roller are barely touching the soil. Skid-steer speed can be increased for this operation, the idea being to collect material from the high spots and leave it in the low areas.

Spreading Fill and Topsoil

Start with parallel arms in “lock-out” position and rake tilted on gauge wheels, since depth of cut is not the objective. Endplates can be installed and the windrow angle set as needed to control the material movement.

Changing Grade

Grade modification can be accomplished during finish grading by angling the rake to collect and windrow the maximum amount of material toward targeted areas.

Thatching Existing Grass Areas

This procedure is done with parallel arms in the “lock-out” position so maximum depth control can be maintained. The skid-steer attachment plate should be tilted forward to support the rake on the front gauge wheels and toothed roller raised so teeth are just grazing the surface. Travel speed should be slow and careful.

Shutting Down

Stop engine.

Lower the lift arms and power rake to the ground.

Purge any air in the system. Hydraulic system leak down, hydraulic system failures, mechanical failures, or movement of control levers can cause equipment to drop or rotate unexpectedly.

Shut off engine, set brake, remove key, remove seat belt, and release operator restraint before leaving the skid-steer operator’s seat.



WARNING

- **Do not disconnect hydraulic lines until all system pressure is relieved. Lower unit to ground, stop engine, and operate all hydraulic control levers.**

REMOVING POWER RAKE FROM SKID-STEER



WARNING

- **Do not allow other people in the area when operating, attaching, removing, assembling, or servicing equipment.**

Install endplates on attachment side of power rake as shown in **Figure 7**.

On a hard level surface, lower attachment to the ground.

Shut off engine, set brake, remove key, remove seat belt, and release operator restraint before leaving the skid-steer operator’s seat.



WARNING

- **Do not disconnect hydraulic lines until all system pressure is relieved. Lower unit to ground, stop engine, and operate all hydraulic control levers.**

Move attachment coupler latches to the unlocked position (lockpins must be disengaged).

OPERATION

Disconnect hydraulic hoses from quick couplers. Install dust plugs and couple hoses together for storage. Disconnect direction control switch from skid-steer power cord and remove switch.

Move to skid-steer seat and start engine. Release brake and roll attachment coupler until it is disengaged from the attachment. The attachment should rest in a stable position for storage.

STORAGE

Make sure the disconnected power rake is stored on a hard, level surface. Endplates mounted on attachment side of rake increase stability.



- Block equipment securely for storage.



- Keep children and bystanders away from storage area.

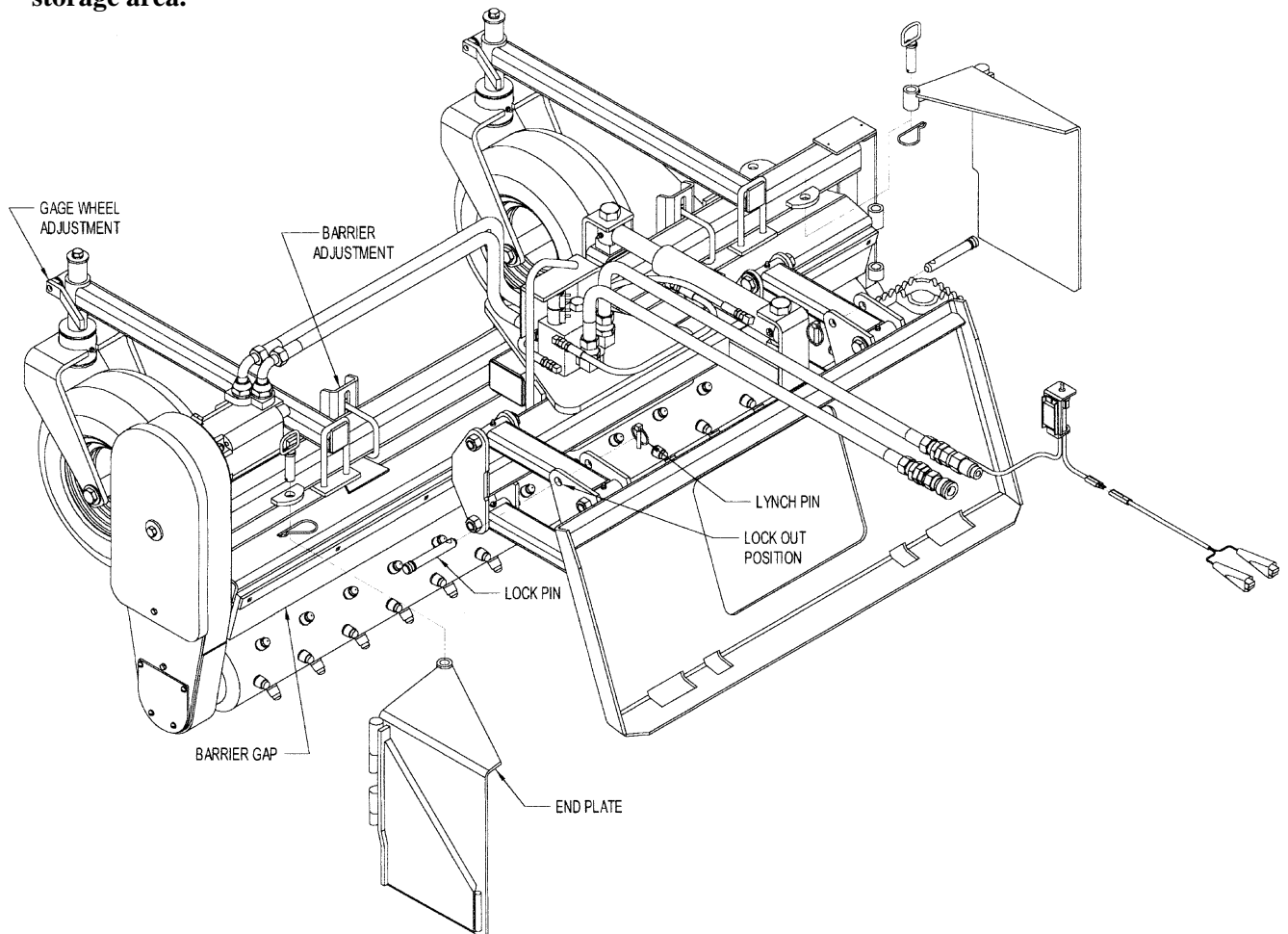

Figure 7. Adjustments

MAINTENANCE

The information in this section is written for operators who possess basic mechanical skills. Should you need help, your dealer has trained service technicians available. For your protection, read and follow all safety information in this manual.

Regular preventive maintenance and immediate repair of broken or worn parts will ensure maximum efficiency and long life.

Because of the nature of the jobs the power rake does, such as site preparation and rock raking, the power rake is constantly vibrating and shaking. Parts may loosen up as it is used. One of the most important functions an operator can perform is observing and inspecting the equipment for loose or worn parts to prevent further damage or excessive downtime.



WARNING

- **Never go underneath equipment lowered to the ground or raised. Never place any part of the body underneath equipment or between moveable parts even when the engine has been turned off. Hydraulic system leak down, hydraulic system failures, mechanical failures, or movement of control levers can cause equipment to drop or rotate unexpectedly and cause severe injury or death.**
 - Service work does not require going underneath.
 - Read Operator's Manual for service instructions or have done by a qualified dealer.
- Before leaving skid-steer operator's seat, follow skid-steer manual instructions. Lower skid-steer lift arms and put attachment on the ground. Stop engine, remove key, engage brake, and remove seat belt/operator restraint.
- Do not allow other people in the area when operating, attaching, removing, assembling, or servicing equipment.
- Never perform service or maintenance with engine running.
- Ensure shields and guards are properly installed and in good condition. Replace if damaged.
- Keep hands and body away from pressurized lines. Use paper or cardboard, not body parts, to check for leaks. Wear safety goggles. Hydraulic fluid under pressure can easily penetrate skin and will cause serious injury or death.



- **Make sure that all operating and service personnel know that in the event hydraulic fluid penetrates skin, it must be surgically removed as soon as possible by a doctor familiar with this form of injury or gangrene, serious injury or death will result. CONTACT A PHYSICIAN IMMEDIATELY IF FLUID ENTERS SKIN OR EYES. DO NOT DELAY.**
- **Make sure all hydraulic hoses, fittings, and valves are in good condition and not leaking before starting power unit or using equipment. Check and route hoses carefully to prevent damage. Hoses must not be twisted, bent sharply, kinked, frayed, pinched, or come into contact with any moving parts. Operate moveable components through full operational range to check clearances. Replace any damaged hoses immediately.**



CAUTION

- Your dealer can supply original equipment hydraulic accessories and repair parts. Substitute parts may not meet original equipment specifications and may be dangerous.
- Always wear relatively tight and belted clothing to avoid entanglement in moving parts. Wear sturdy, rough-soled work shoes and protective equipment for eyes, hair, hands, hearing, and head.



WARNING

- Do not modify or alter, or permit anyone else to modify or alter, the equipment or any of its components in any way.
- Ensure all safety decals are installed. Replace if damaged. (See Safety Decals section for location.)

DAILY MAINTENANCE

When operating the power rake, check the skid-steer hydraulic system to be sure the level of hydraulic oil is adequate. If necessary, add hydraulic oil as recommended in your skid-steer operator's manual.

Repair hydraulic oil leaks promptly to avoid loss of oil and serious personal injury from escaping oil.

After every 10 hours of operation, check all hardware and tighten where required.

Lightly lubricate bearing at each end of roller.

Check oil level in chain case.

MAINTENANCE

WEEKLY MAINTENANCE

Lubricate all pivot points.

Inspect drive chain.

Check tire pressure. Maintain 45 psi cold.

MONTHLY MAINTENANCE

Inspect and clean safety decals. Replace if damaged. (See **Safety Decals** section for location.)

QUARTERLY MAINTENANCE

Change oil in chain case and add 1.5 pints of 140 wt. lube.

PRELIMINARY CHECK

The best maintenance is regular preventive checks, particularly when the machine is new. Check that all nuts and bolts are tight.

CHAIN MAINTENANCE

The drive chain should be inspected weekly. New chain has a tendency to stretch, so it is necessary to

check the chain tension to prevent flopping around, thus causing potential problems.

Chain tension is preset with the extension spring. If the chain becomes excessively loose, it may be necessary to remove one link (two pitches). If unable to reassemble, add an offset link to lengthen the chain.

IMPORTANT

- **Replacement chain should be only high quality original equipment chain for longer life.**

When being stored for a long period or at end of season, change the oil, adding EP 140 wt. oil, and rotate the roller several times allowing the chain to be coated with oil, enhancing chain life. Rotate the roller periodically to maintain lubrication. In order to rotate the roller and chain you must hook the two hydraulic hoses together.

SPROCKETS

Sprockets should be checked to be sure slotted hex nut or hex bolt is tight, the cotter pin is in place, and the sprocket cannot move on shaft.

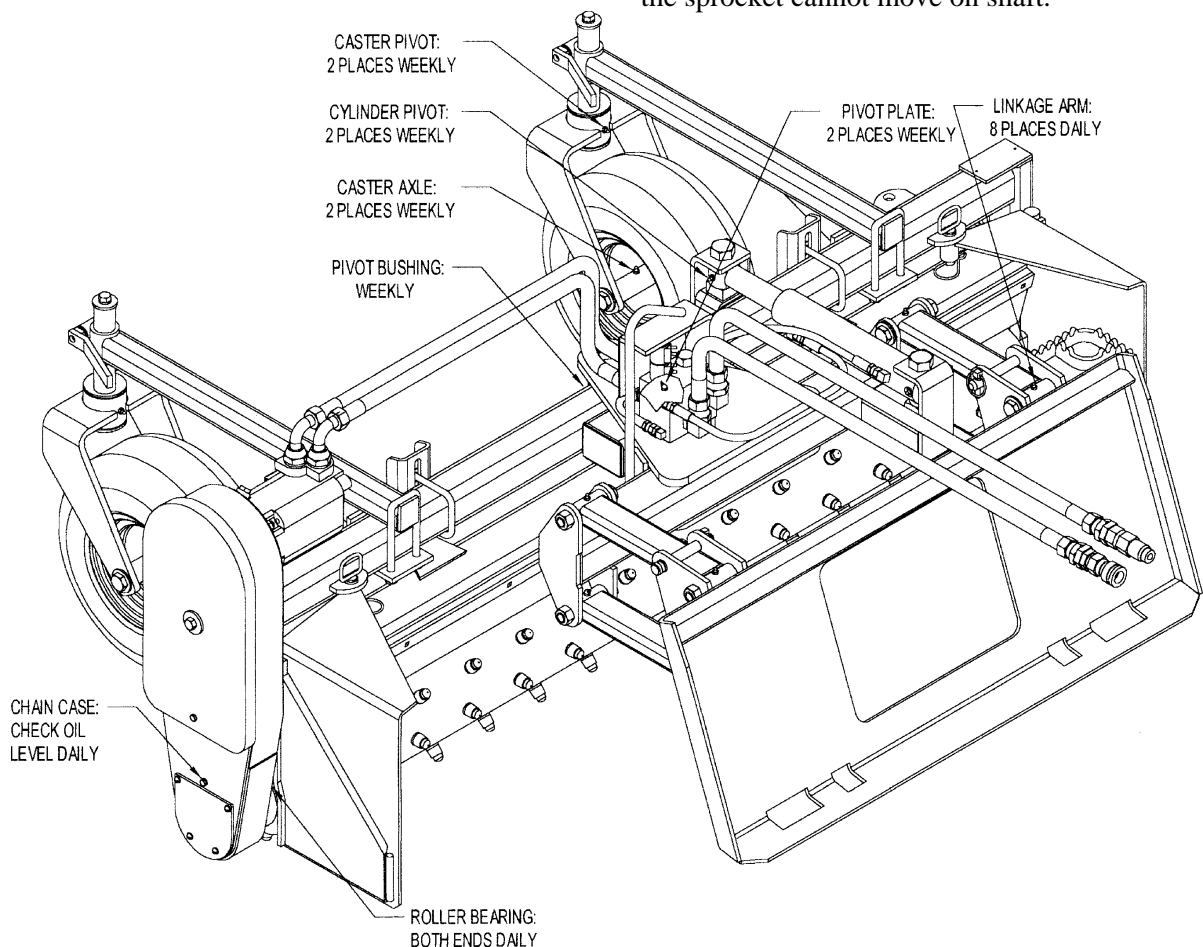

Figure 8. Lubrication Maintenance

TROUBLE SHOOTING

Problem	Possible Cause	Solution
Roller will not turn	Hydraulic valve on skid-steer not engaged	See skid-steer Operator's Manual for auxiliary hydraulic operation procedure.
	Relief valve setting on skid-steer not properly adjusted	Have skid-steer dealer set relief valve at correct pressure.
	Worn, damaged, insufficient, or inadequate pump	Repair or replace hydraulic pump.
	Insufficient oil in system	Service the skid-steer hydraulic reservoir.
	Hose ends not completely engaged	Check hose coupling and engage properly.
	Air in hydraulic lines	Cycle skid-steer auxiliary system several times to remove air from lines.
	Obstruction in hydraulic lines	Replace obstructed or damaged line.
	Obstruction between roller and barrier	Reverse roller to clear obstruction.
Oil leaks.	Chain off	Repair or replace chain.
	Worn or damaged seal	Replace leaking seal.
	Loose or damaged hoses	Replace damaged hoses and secure loose hoses.
	Loose or damaged connections	Replace damaged hose connections and tighten loose fittings.
	Worn or damaged housing	Replace damaged housing.
	Roller out of position	Loosen bearing collar on frame and chain case. Force roller toward chain case, then tighten bearing collars on chain case and frame.
	Angle cylinder will not extend or retract	Electrical failure
Hydraulic system not activated		Engage roller drive motor before attempting to move angle cylinder.
Angle cylinder will not hold position	Check-valve in manifold malfunctioning	Repair or replace check-valve.
	Solenoid cartridge not returning to closed position	Repair or replace solenoid cartridge.

MAINTENANCE

The information in this section is written for dealer service personnel. The repair described herein requires special skills and tools. If your shop is not properly trained in this type of repair, you may be time and money ahead to replace complete assemblies.



WARNING

- **Never go underneath equipment lowered to the ground or raised. Never place any part of the body underneath equipment or between moveable parts even when the engine has been turned off. Hydraulic system leak down, hydraulic system failures, mechanical failures, or movement of control levers can cause equipment to drop or rotate unexpectedly and cause severe injury or death.**
 - **Service work does not require going underneath.**
 - **Read Operator's Manual for service instructions or have done by a qualified dealer.**



CAUTION

- **Always wear relatively tight and belted clothing to avoid entanglement in moving parts. Wear sturdy, rough-soled work shoes and protective equipment for eyes, hair, hands, hearing, and head.**
- **Do not allow other people in the area when operating, attaching, removing, assembling, or servicing equipment.**
- **Do not modify or alter, or permit anyone else to modify or alter, the equipment or any of its components in any way.**
- **Do not disconnect hydraulic lines until all system pressure is relieved. Lower unit to ground, stop engine, and operate all hydraulic control levers.**
- **Ensure implement is properly attached, adjusted, and in good operating condition.**
- **Ensure all safety decals are installed. Replace if damaged. (See Safety Decals section for location.)**
- **Ensure shields and guards are properly installed and in good condition. Replace if damaged.**

HYDRAULIC MOTOR

Removal

Remove chain from top sprocket. Then remove top sprocket by removing the hex bolt and washers.

Reassembly

Apply a liberal amount of silicone sealer to inside of flange. Attach hydraulic motor to chain case with four bolts, flange, and nuts. Replace collar over shaft. Slide top sprocket, sprocket teeth first, onto shaft. Use machine bushings on the inside or outside of sprocket for proper alignment.

BEARINGS

Highest quality bearings are used on the power rake. Only triple-seal bearings are used on the roller which operates down in the dirt. Lubrication of bearings will vary considerably with conditions. As a rule, bearings should be under-lubricated rather than over-lubricated. Over-lubrication can cause seals to blow out.

IMPORTANT

- **Replacement bearings should be only high quality original equipment bearings for longer life.**

Install new complete bearing housing if needed or just replace the bearing insert.

The shafts should be straight, free of burrs, and up to size. If shaft is worn, replace or have the shaft built up to standard prior to completing assembly.

Protective Collars

The special protective collars protect bearings from vine and wire wrap, and dirt buildup next to the bearing seal. The bearing protector is sandwiched onto the shaft which rotates within a close clearance from the outer race of the bearing. Grease coming from the bearing oozes into the protecting collar, keeping dust and particles from entering the seal area, increasing the bearing life.

Left Roller Bearing

Remove drive chain. Then remove lower sprocket by removing cotter pin, slotted hex nut, and washers.

Remove the two bolts holding the chain case to the frame.

MAINTENANCE

NOTE: Have roller blocked up or supported and slide chain case and bearing off roller shaft.

Loosen bolt on the bearing tube that holds cartridge bearing in place. Remove bearing and O-ring.

To replace, reverse the procedure. Be sure all parts and wear surfaces are thoroughly clean and in good condition. Be sure O-ring is also in good condition.

When replacing bearing, first put O-ring on bearing. Apply a coat of grease on O-ring. Slide bearing in and apply moderate pressure on bearing so O-ring will seat and spread slightly, thus keeping the oil in chain case from escaping through the bearing.

Right Roller Bearing

Remove the hex bolt and bearing cap from outside of bearing.

Loosen bolt on the bearing tube that holds cartridge bearing in place. Pry bearing tube apart to free bearing assembly.

NOTE: Have roller blocked up or supported. Pry bearing off of shaft and out of bearing holder.

To replace, reverse the procedure. Be sure all parts and wear surfaces are thoroughly clean and in good condition.

ROLLER REPLACEMENT

It will be necessary to have a lifting device or additional help while removing and replacing the roller. The roller weighs approximately 150 lbs.

Remove upper and lower chain case covers.

Disconnect the two hydraulic hoses from motor. Protect hose ends and fittings from being contaminated.

Remove tension spring and drive chain. Then remove lower sprocket by removing cotter pin, slotted nut, and washers. Remove the sleeve behind the sprocket you just removed.

NOTE: Have the roller blocked up or supported.

Remove the two bolts holding chain case to frame and slide chain case, with hydraulic motor attached, off of roller shaft. The roller bearing will stay in the chain case.

NOTE: If chain case bearing is also being replaced, see **Left Roller Bearing** above.

Loosen the bolt on the bearing tube of the non-drive end, sliding roller and bearing out of frame.

Remove hex bolt, bearing cap, bearing, and protective collar from roller. On roller to be installed, place machine bushing and protective collar against endplate of roller. Place bearing and bearing cap on roller. Clamp in place with hex bolt and lockwasher into end of roller shaft.

Slide roller and bearing into bearing tube on non-drive end of frame. Do **not** tighten bearing tube at this time.

Place spacer and protective collar from splined end of removed roller onto replacement roller. Apply sealant to bearing area of shaft. Slide chain case back onto roller and bolt to frame.

Replace sleeve, sprocket, and washers on driveshaft. Clamp solid with the 1" slotted jam nut. Check that roller clears frame on both ends. Adjust if required.

Now, tighten 3/8" bolt in bearing tube on non-drive end of frame.

Reinstall chain and tension spring.

Replace lower cover, being careful not to pinch the O-ring. Fill the chain case with 1.5 pints of 140 wt. gear oil. Replace upper cover.

Run power rake and watch for any interference between roller and frame.

MAINTENANCE

DIRECTION CONTROL VALVE

A three position switch (normally open) is used to operate the direction control valve. 12V control power is supplied by the skid-steer power cord attached to the skid-steer electrical system. The switch wires are connected to the direction control valve as shown in **Figure 9**.

The direction control valve uses a small amount of hydraulic oil bypassed from the roller drive motor circuit. The skid-steer auxiliary hydraulic system must be connected and engaged to provide angle direction adjustment; the roller must be rotating clockwise.

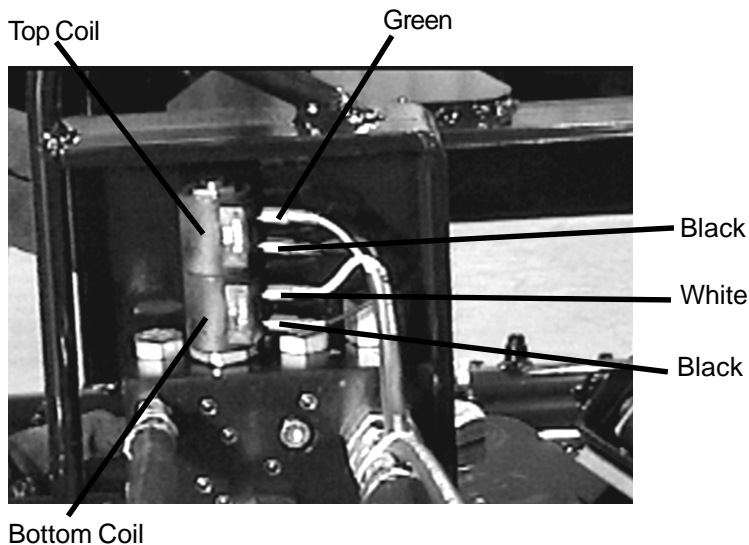

Figure 9. Direction Control Valve

ASSEMBLY



CAUTION

- **Always wear relatively tight and belted clothing to avoid entanglement in moving parts. Wear sturdy, rough-soled work shoes and protective equipment for eyes, hair, hands, hearing, and head.**



WARNING

- **Keep hands and body away from pressurized lines. Use paper or cardboard, not body parts, to check for leaks. Wear safety goggles. Hydraulic fluid under pressure can easily penetrate skin and will cause serious injury or death.**
- **Make sure that all operating and service personnel know that in the event hydraulic fluid penetrates the skin, it must be surgically removed as soon as possible by a doctor familiar with this form of injury or gangrene, serious injury, or death will result. CONTACT A PHYSICIAN IMMEDIATELY IF FLUID ENTERS SKIN OR EYES. DO NOT DELAY.**
- **Route hydraulic hoses carefully to prevent damage. Hoses must not be twisted, bent sharply, kinked, frayed, pinched, or come into contact with any moving parts. Operate moveable components through full operational range to check clearances. Replace any damaged hose immediately.**
- **Do not allow other people in the area when operating, attaching, removing, assembling, or servicing equipment.**
- **Do not modify or alter, or permit anyone else to modify or alter, the equipment or any of its components in any way.**

SET-UP INSTRUCTIONS

The power rake is shipped partially assembled. Assembly will be easier if components are aligned and loosely assembled before tightening hardware. Recommended torque values for hardware are located on page 5.

Select a suitable working area. Refer to illustrations, accompanying text, parts lists, and exploded view drawings.

Tools Required

3/4 and 1-1/8 Combination wrenchs.

It is advisable to have a mechanical lifting device to facilitate uncrating.

Unpacking Crate

Be careful of nails in boards when uncrating.

Remove top, sides, and ends of crate.

Remove attachment plate.

Remove endplates.

Remove gauge wheel assemblies.

Remove parts box.

Remove power rake from crate. Remove loose nails from boards and dispose of crate according to local codes.

ASSEMBLY

ASSEMBLY PROCEDURE

For reference, front, back, left and right directions are determined by sitting in the skid-steer operator's seat.

Do not permit any bystanders within 10 feet of power rake during assembly.



WARNING

- **Do not allow other people in the area when operating, attaching, removing, assembling, or servicing equipment.**
- **Avoid electrical system hazards.**
 - **Never work on the electrical system unless you are qualified and thoroughly familiar with system details and the special handling requirements.**
 - **Disconnect battery before working on electrical system. Remove "ground" cable first. When reconnecting battery, connect "ground" cable last.**

Raise front of rake up so pivot frame is horizontal.

Mount the left and right endplates. Put in place with 3/4" X 2-7/8" pins with hairpin clips. These plates can be mounted to the front or back of power rake, depending on raking direction. When you move endplates from front to back, you must move the left one to the right and the right one to the left.

Move attachment mounting plate into position in front of rake.

Attach the four link arms to the attachment plate (lower arms first). Tighten nuts after all four arms are in place.

Replace the 3/4" X 4-3/4" pins in either the "lockout" or "float" position (see **Parallel Arms** on page 15).

Attach the two gauge wheel assemblies to main frame with two 1/2" U-bolts, lockwashers, and nuts as shown in **Figure 10**.

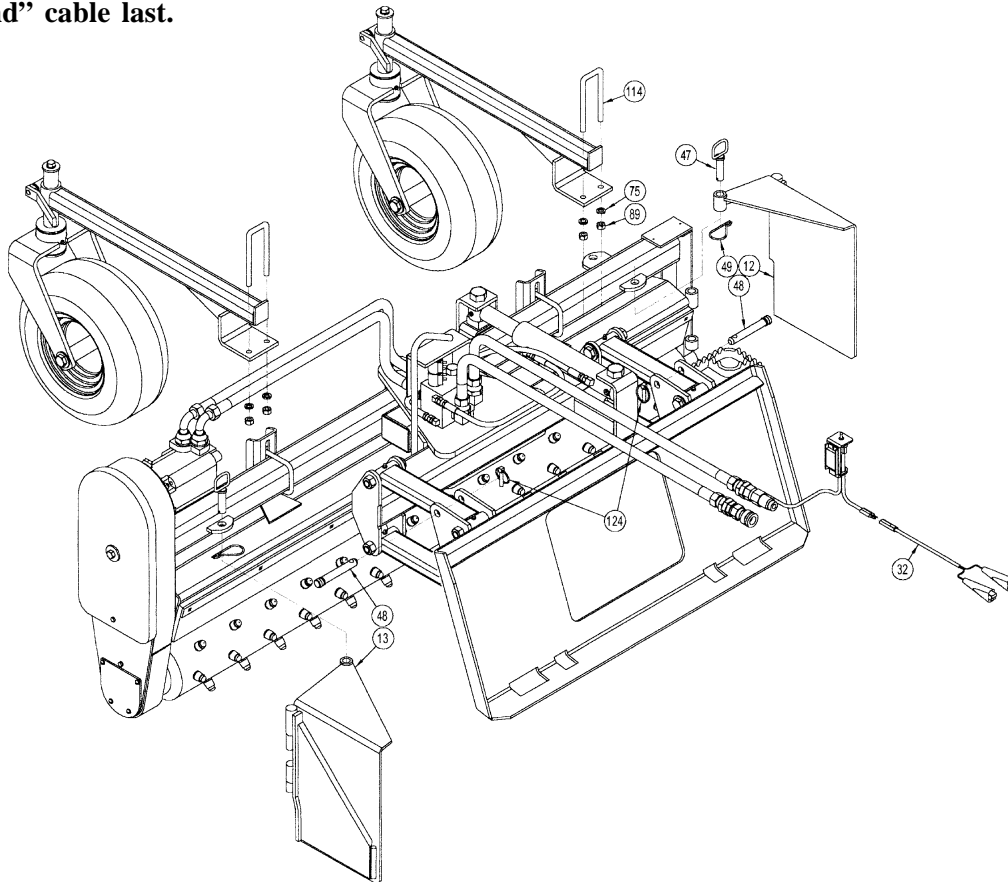

Figure 10. Power Rake Assembly

ASSEMBLY

Install skid-steer power cord by connecting the red wire to a positive 12 volt power source and the white wire to ground. The power cord includes an in-line fuse and spring-loaded battery clamps. The red (positive) cable is fused and should always be connected to the positive side of the battery to ensure proper operation of the electrical circuit. Be careful when routing the cable that sharp edges or moving parts will not damage it.

Check the oil level in the chain case. If needed, add EP 140 wt. gear oil. See instructions near fill/vent plug, **Figure 11**.

WARNING

- **Make sure all hydraulic hoses, fittings, and valves are in good condition and not leaking before starting power unit or using equipment. Check and route hoses carefully to prevent damage. Hoses must not be twisted, bent sharply, kinked, frayed, pinched, or come into contact with any moving parts. Operate moveable components through full operational range to check clearances. Replace any damaged hoses immediately.**

Check that shields and guards are properly installed and in good condition. Replace if damaged.

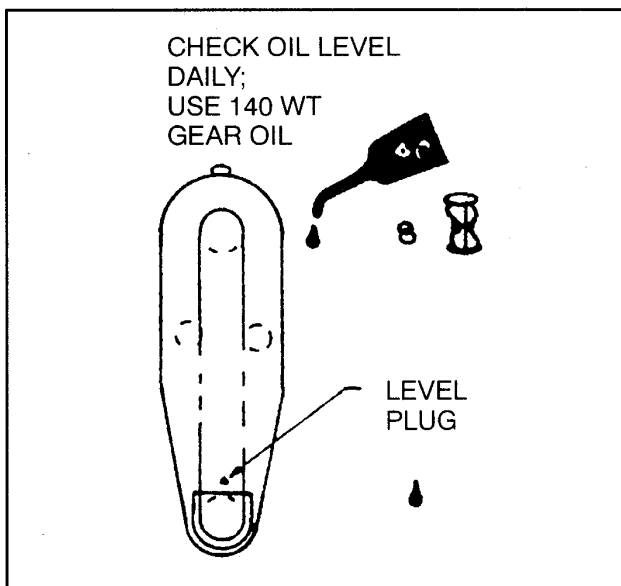

Figure 11. Chain Case Oil Level

HYDRAULIC SCHEMATIC

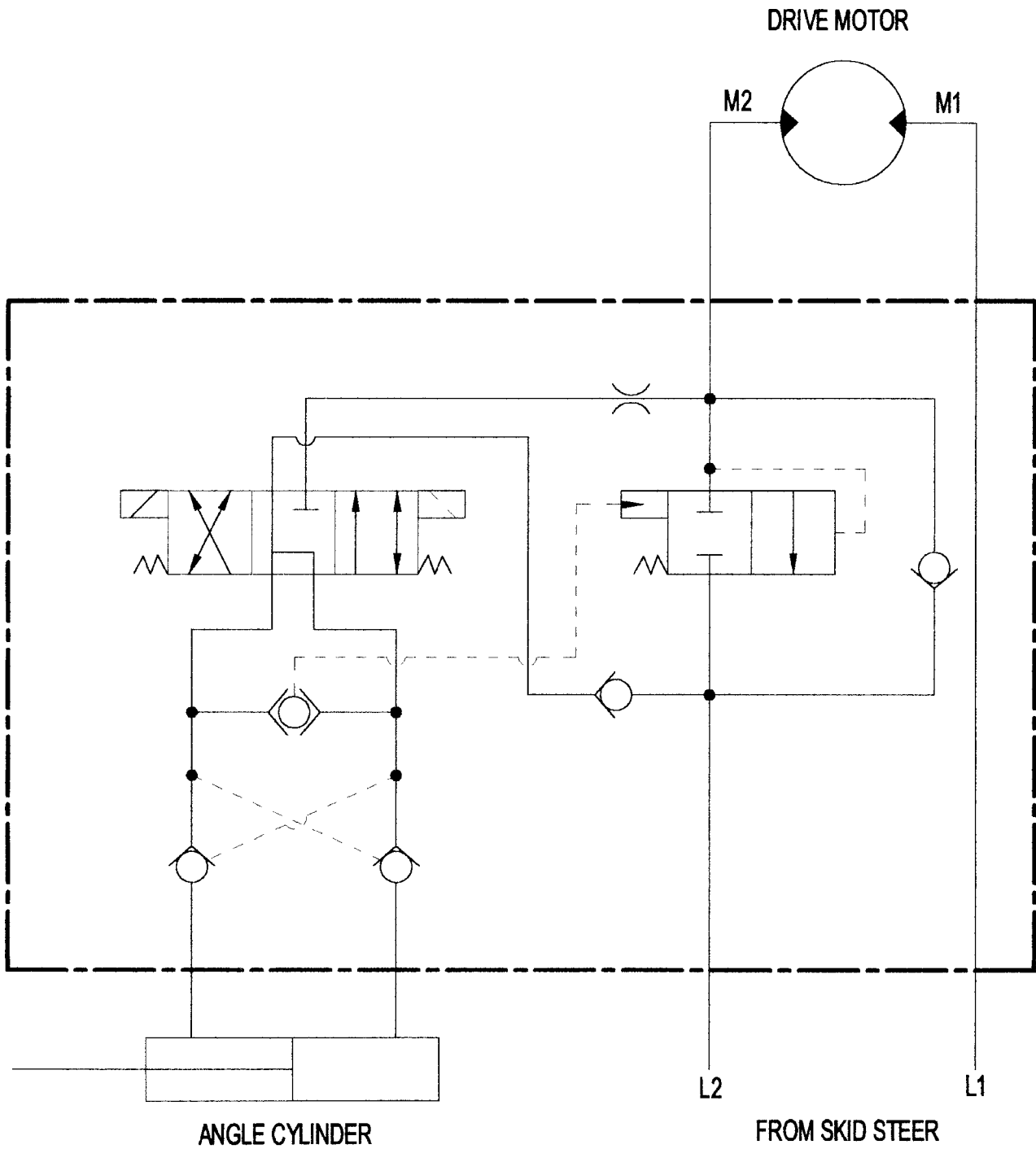

FIGURE 12

Figure 12. Hydraulic Schematic

FINAL ASSEMBLY

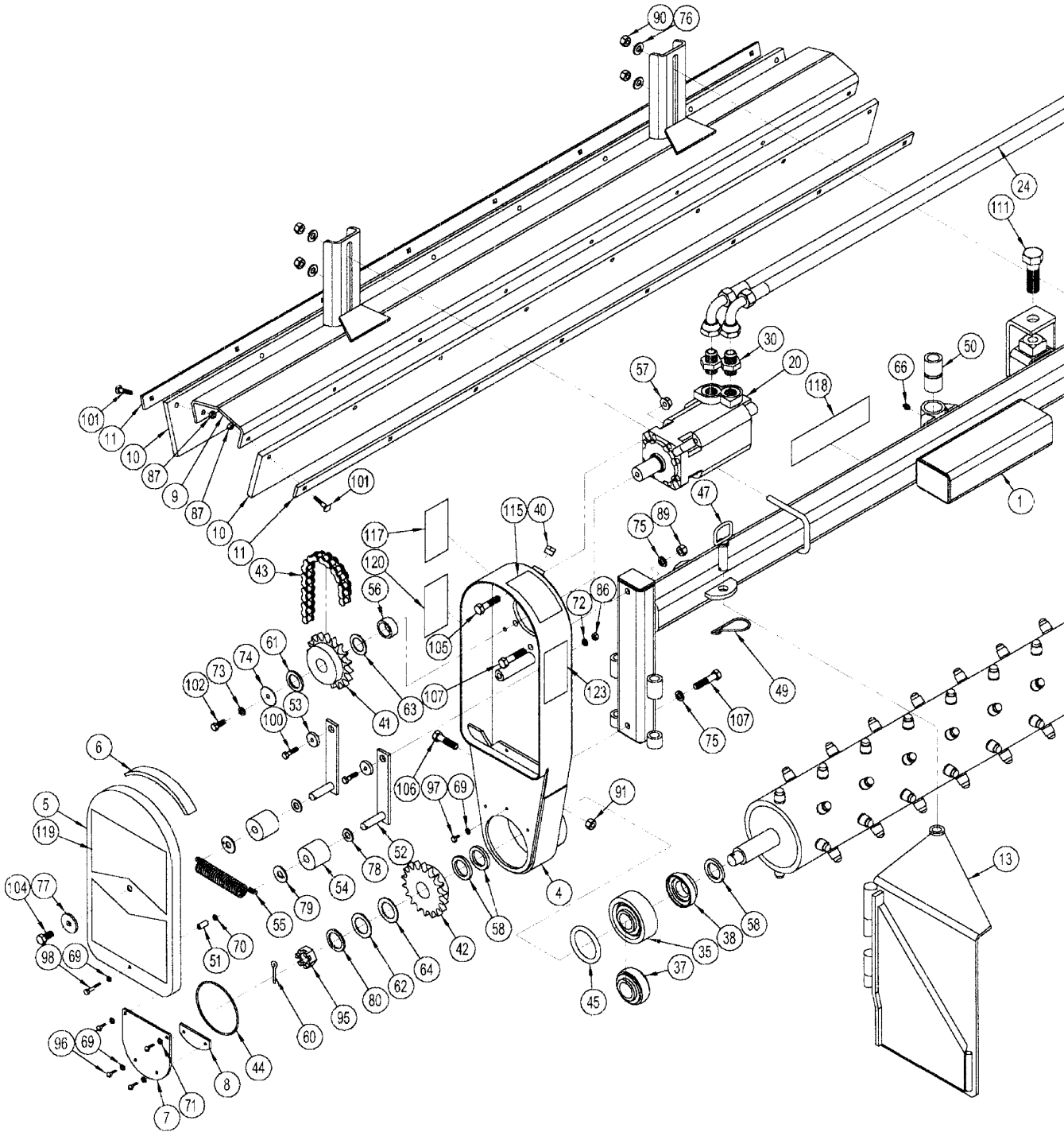

Figure 13

FINAL ASSEMBLY

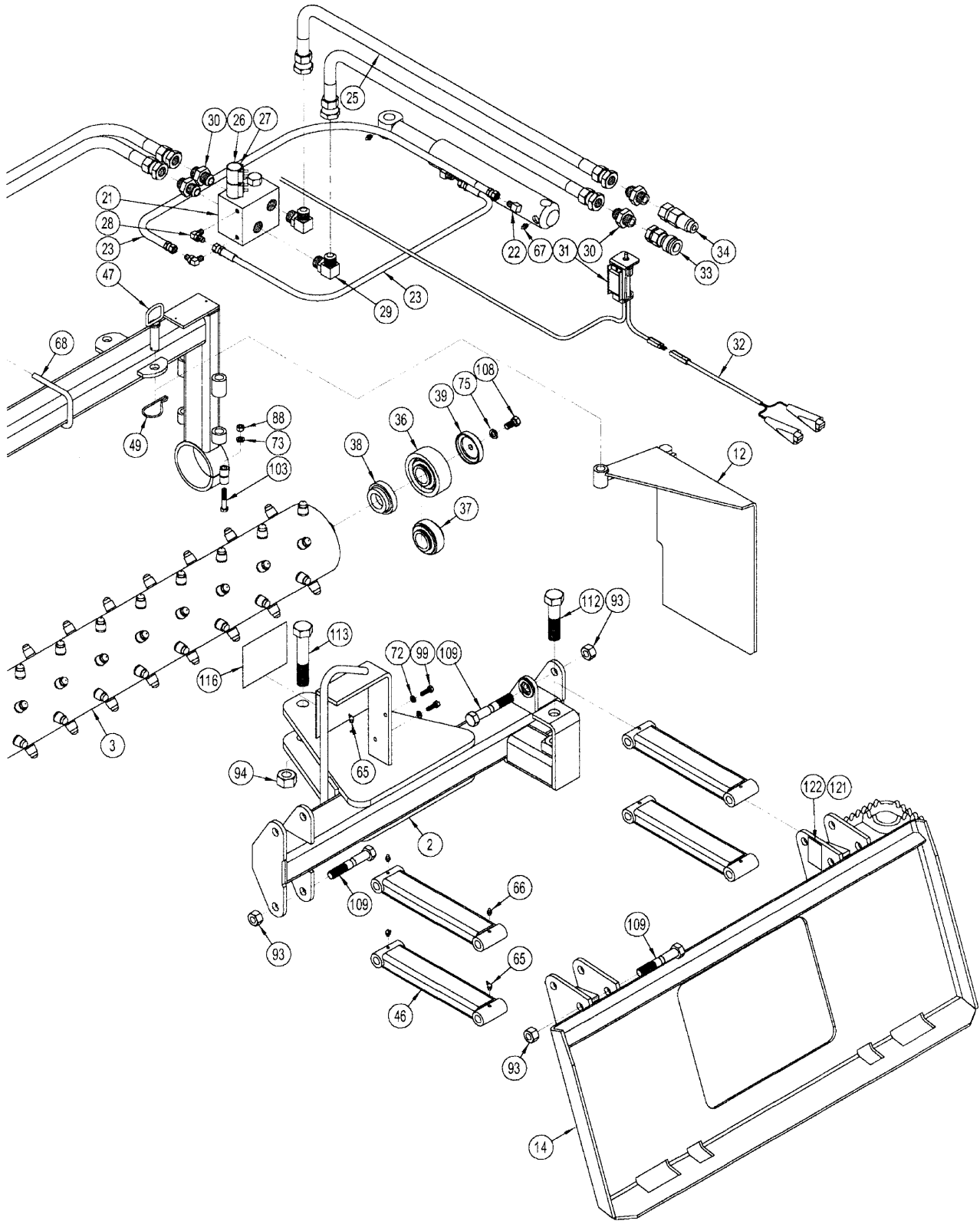
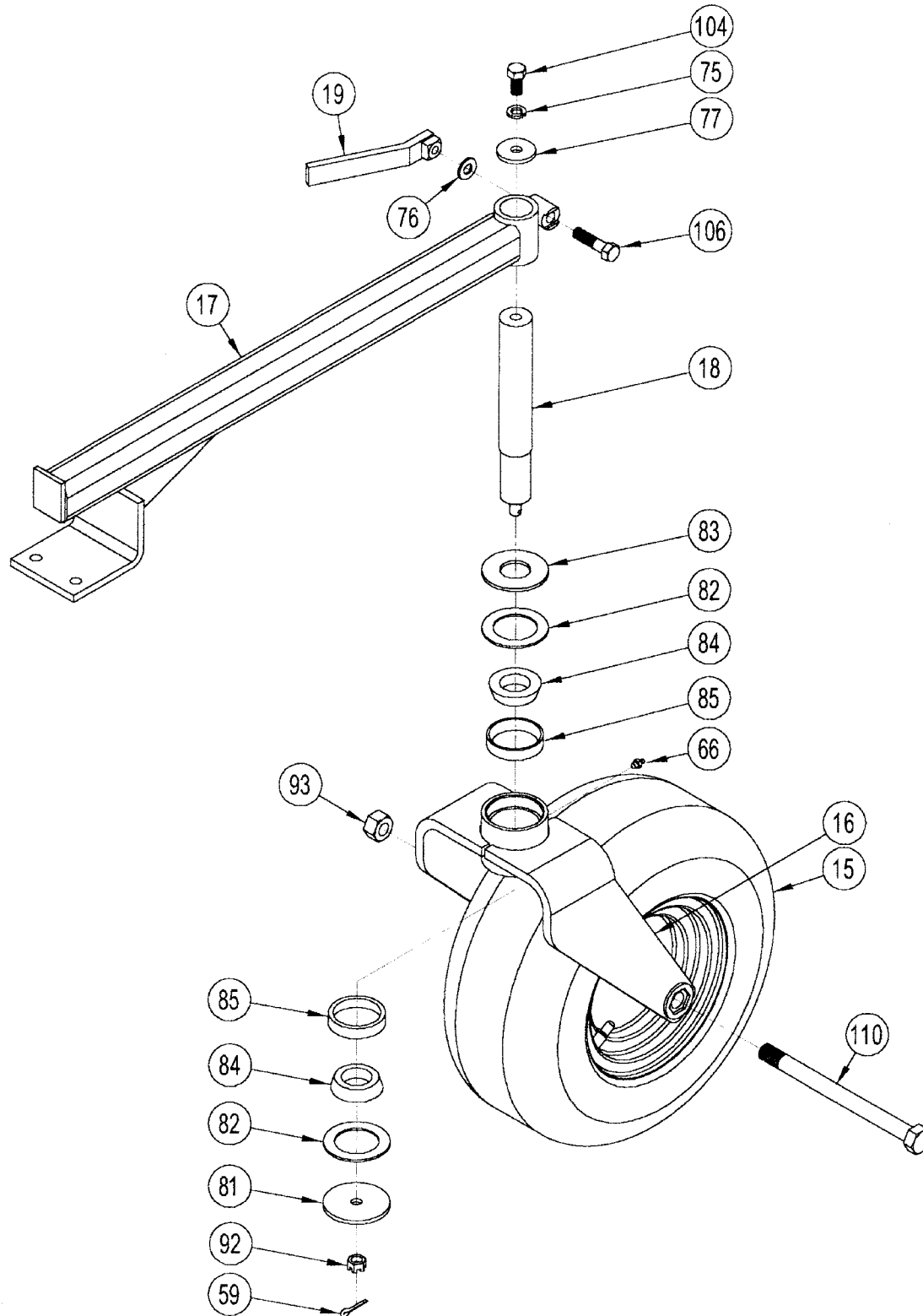

Figure 13

CASTER WHEEL



PARTS LIST

ITEM	QYT	PART NO.	DESCRIPTION	ITEM	QYT	PART NO.	DESCRIPTION
1	1	M6803	MAIN FRAME	66	8	P620200	1/4-28 STR GREASE FITTING
2	1	M6809	PIVOT FRAME	67	2	P620500	1/4 NPT STR GREASE FITTING
3	1	M6775	CARBIDE TOOTH ROLLER	68	2	P128318	U-BOLT 1/2" X 3" X 4"
4	1	M6608	CHAIN CASE	69	4	P500300	1/4" O-RING WASHER
5	1	M6618	COVER	70	1	P500302	1/4" RUBBER FACE WASHER
6	1	M6642	COVER SEAL	71	2	P851104	1/4" LOCK WASHER
7	1	M8241	LOWER COVER	72	4	P851105	5/16" LOCK WASHER
8	1	M8272	COVER TAB	73	2	P851106	3/8" LOCK WASHER
9	1	M6796	BARRIER MOUNT	74	1	M5009-2	3/8" X 1-3/4" FLAT WASHER
10	2	M6427	BARRIER	75	9	P851108	1/2" LOCK WASHER
11	2	M6428	BARRIER STRAP	76	6	P852608	1/2" HARD WASHER
12	1	M6624	END PLATE RIGHT	77	3	M5009-5	3/16" X 1/2" X 1-3/4" WASHER
13	1	M6625	END PLATE LEFT	78	2	P850609	9/16" FLAT WASHER
14	1	M6812	ATTACHMENT MOUNT	79	2	M6756	PINNED WASHER
15	2	P756100	WHEEL & TIRE	80	1	P851616	1" HEAVY HARD WASHER
16	2	M6817	CASTER FORK	81	2	M6223	WASHER
17	2	M16012	CASTER SUPPORT ARM	82	4	P852200	FELT WASHER
18	2	M16011	CASTER SHAFT	83	2	P850620	1-1/4" FLAT WASHER
19	2	M6415	HANDLE	84	4	P760300	BEARING CONE
20	1	P350200	HYDRAULIC MOTOR 109-1117	85	4	P760500	BEARING CUP
21	1	P243000	HYDRAULIC MANIFOLD	86	2	P150500	5/16" HEX NUT
22	1	P257500	2" X 8" HYDRAULIC CYLINDER	87	16	P155350	5/16" CENTER LOCK NUT
23	2	P246000	-4 HOSE X 27" 4FJX-6FJX	88	1	P150600	3/8" HEX NUT
24	2	P255685	-10 HOSE X 44" 12FJX-12FJX90°	89	5	P150800	1/2" HEX NUT
25	2	P255736	-10 HOSE X 66" 12FJX-12FJX	90	4	P158005	1/2" NYLOCK NUT
26	1	P243001	SOLENOID CARTRIDGE	91	1	P155852	1/2"-20 LOCK NUT
27	2	P290304	SOLENOID COIL	92	2	P158006	1/2"-13 SLOTTED HEX NUT
28	2	P261400	ELBOW -4MB-4MJ90°	93	10	P157120	3/4" CENTRE NUT
29	2	P276480	ELBOW 12MJ-12MB90°	94	1	P156401	1" LOCK NUT
30	6	P276450	ADAPTER 12MJ-12MB	95	1	P156402	1" SLOTTED HEX NUT
31	1	M6725	SWITCH ASSEMBLY	96	4	P110901	1/4" X 3/4" BUTTON HEAD SCREW
32	1	M6726	CABLE ASSEMBLY	97	1	P100402	1/4" X 1/2" HEX BOLT
33	1	P272670	FEMALE FLAT FACE COUPLER	98	1	P100406	1/4" X 1-1/2" HEX BOLT
34	1	P272671	MALE FLAT FACE COUPLER	99	2	P100504	5/16" X 1" HEX BOLT
35	1	M6687	BEARING ASSEMBLY DRIVE	100	2	P100505	5/16" X 1-1/4" HEX BOLT
36	1	M6688	BEARING ASSEMBLY IDLE	101	16	P104506	5/16" X 1-1/2" CARRIAGE BOLT
37	2	P010400	1-1/2" BEARING INSERT	102	1	P100604	3/8" X 1" HEX BOLT
38	2	P015308	1-1/2" NON LOCK COLLAR	103	1	P100608	3/8" X 2" HEX BOLT
39	1	P015307	1-1/2" BEARING CAP	104	3	P100804	1/2" X 1" HEX BOLT
40	1	P278001	VENT PLUG	105	4	P100808	1/2" X 2" HEX BOLT
41	1	P661804	18 TOOTH SPROCKET 1-1/4" SPLINE	106	3	P102808	1/2" X 2" FINE THD HEX BOLT
42	1	P661805	18 TOOTH SPROCKET 1-1/2" SPLINE	107	2	P100812	1/2" X 3" HEX BOLT
43	1	M6641	DRIVE CHAIN #60H-75P	108	1	P102804	1/4" X 1-1/4" FINE THD HEX BOLT
44	1	P500202	O-RING 3/32" X 4-3/4"	109	8	M6816	3/4" X 4-1/2" HEX BOLT
45	1	P500203	O-RING 3/8" X 2-5/8"	110	2	P103138	3/4" X 9-1/2" CASTER BOLT
46	2	M6795	LINK ARM	111	1	M6815	1" X 3-1/8" HEX BOLT
47	2	M6442	3/4" X 2-1/2" CLEVIS PIN	112	1	P101616	1" X 4" HEX BOLT
48	2	P120210	3/4" X 3-7/8" CLEVIS PIN	113	1	P101622	1" X 5-1/2" FINE THD HEX BOLT
49	2	P622600	HAIR PIN CLIP	114	2	P128324	1/2" U-BOLT
50	1	M6637	PIVOT BUSHING	115	1	P970300	DECAL: WARNING CHAIN
51	1	P481010	BUSHING	116	1	P970250	DECAL: WARNING ROLLER
52	2	M6629	TENSION ARM	117	1	P970003	DECAL: LUBRICATION
53	2	M6630	PIVOT BUSHING	118	1	P975801	DECAL: HARLEY (WHITE)
54	2	M6628	IDLER ROLLER	119	1	P975917	DECAL: S-6 BOX RAKE
55	1	P604605	EXTENSION SPRING	120	1	P975602	DECAL: GAGE WHEEL
56	1	M6634	COLLAR	121	1	P970011	DECAL: LOCK-OUT
57	4	P155851	1/2" SERRATED FLANGE NUT	122	1	P970010	DECAL: LOCK-OUT
58	3	M6757	SPACER .218 LONG	123	1	P970004	DECAL: WARNING LIFT
59	2	P116204	1/8" X 1" COTTER PIN	124	2	P126207	7/16 LYNCH PIN
60	1	P116306	3/16" X 1-1/2" COTTER PIN				
61	1	P855120	10 GA X 1-1/4" MACHINE BUSHING				
62	1	P855124	10 GA X 1-1/2" MACHINE BUSHING				
63	1	P855320	14 GA X 1-1/4" MACHINE BUSHING				
64	1	P855324	14 GA X 1-1/2" MACHINE BUSHING				
65	5	P620000	1/4-28 X 45° GREASE FITTING				

LIMITED WARRANTY

GLENMAC, INC. warrants, to the original purchaser of the HARLEY POWER BOX RAKE®, that it will repair or replace any manufactured parts thereof found to be, under normal use, defective in factory material or workmanship for six (6) months from the date of purchase.

This warranty shall become void if in the judgment of GLENMAC, INC. the equipment has been subject to misuse, negligence, alteration, damaged by accident or lack of required maintenance, or if the product has been used for a purpose for which it was not intended. Wear items such as, but not limited to, rollers and chain cases will not be covered under warranty.

This warranty does not apply to hydraulic motor, electric actuator, tires, bearing, sprockets, or any other trade accessories not manufactured by GLENMAC, INC. Buyer must rely solely on the existing warranty, if any, of these respective manufacturers.

This warranty will become void if a valid warranty registration card is not received by GLENMAC, INC. at its JAMESTOWN, ND office within ten (10) days of original purchase.

Certain HARLEY dealers provide Limited Warranty replacement service. We would suggest that you contact your selling dealer and attempt to resolve your warranty service problem locally prior to contacting our home office. Any questions concerning warranty service can be directed to our Customer Service Department at PO Box 2135 Jamestown, ND, 58402, or call (701) 252-9300.

THERE IS NO OTHER EXPRESSED OR IMPLIED WARRANTY ON THIS PRODUCT OR ON ITS MERCHANTABILITY OR ON ITS FITNESS. TO THE EXTENT ALLOWED BY LAW, NEITHER GLENMAC, INC. NOR THE SELLING HARLEY DEALER SHALL HAVE ANY RESPONSIBILITY FOR LOSS OF USE OF THE PRODUCT, LOSS OF TIME, INCONVENIENCE, COMMERCIAL LOSS OR CONSEQUENTIAL DAMAGES.

Some states do not allow limitations on the exclusion or limitation of incidental or consequential damages, therefore the above limitations may not apply to you.

This warranty gives you specific legal rights that vary from state to state.

Please enter information below and **SAVE FOR FUTURE REFERENCE.**

Date Purchased: _____ From (Dealer): _____

Model Number: S.6 Serial Number: _____

Glenmac, Inc.
1805 2nd Avenue SW
Jamestown, ND 58401
701-252-9300 tel
701-252-1978 fax
701-252-9259 parts fax

Harley

by

Glenmac
INC

Glenmac Inc

1805 2nd Avenue SW
Jamestown ND 58401

701-252-9300 tel
701-252-1978 fax
701-251-9259 parts fax

SN: S60G001

PN-P970640 (02/2000)