

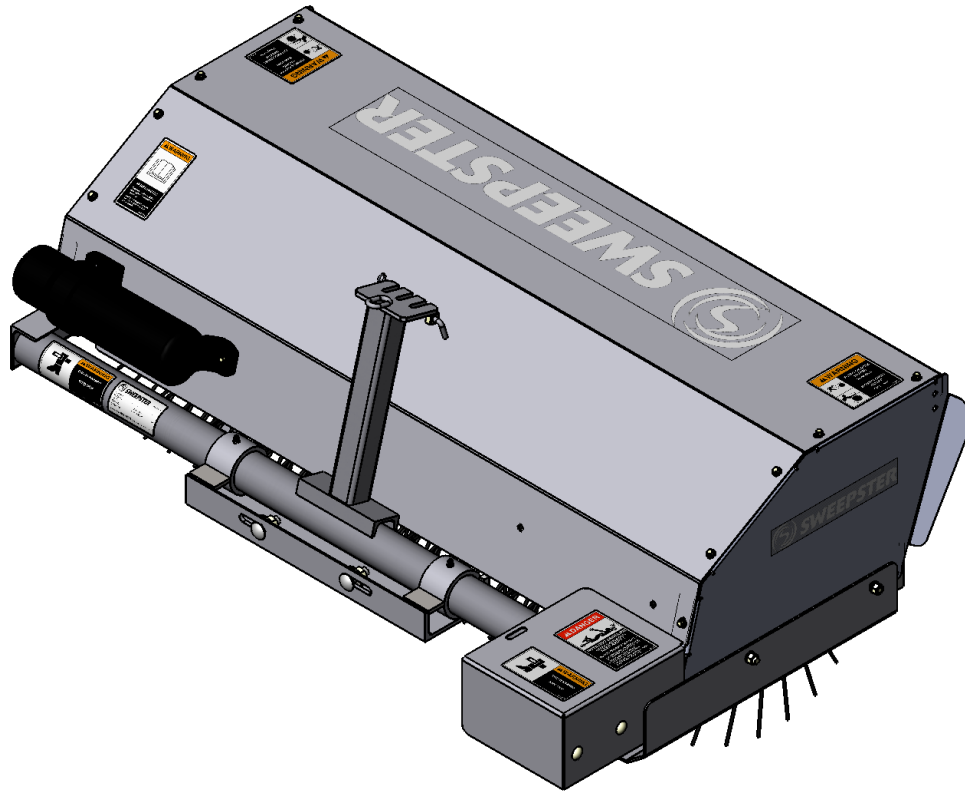

SWEEPSTER

BY PALADIN

OPERATOR'S AND PARTS MANUAL M24 Series L4800, MRM & CTM Mechanical Windrow Sweepers



Serial Number: _____

Model Number: _____

**Manual Number: 51-3000
Release Date: January 2014
Rev. 1**

NOTES

TABLE OF CONTENTS

INTRODUCTION	4
SAFETY STATEMENTS	4
GENERAL SAFETY PRECAUTIONS.....	5-6
SAFETY SIGNS & LABELS	7
INSTALLATION & ADJUSTMENTS.....	8-15
OPERATION.....	16-17
STORAGE	17
MAINTENANCE	18-21
TROUBLESHOOTING	22-23
BRUSH HEAD ASSEMBLY	24-25
DRIVE ASSEMBLIES 1-WAY	26-33
DRIVE ASSEMBLIES 2-WAY	34-43
GEARBOXES	44-47
MANUAL ANGLE KIT	48
OPTION - DIRT DEFLECTORS	49-50
OPTION - HYDRAULIC ANGLE KIT	51-52
OPTION - HYDRAULIC LIFT KITS	53-56
BOLT TORQUE SPECIFICATIONS	57
HYDRAULIC TORQUE SPECIFICATIONS.....	58-59
GLOSSARY	60-61
WARRANTY	62

INTRODUCTION

SAFETY STATEMENTS

Purpose of Sweeper

This sweeper is designed solely for the use in construction cleanup, road maintenance and similar operations. Use in any other way is considered contrary to the intended use. Compliance with and strict adherence to operation, service and repair conditions, as specified by the manufacturer, are also essential elements of the intended use.

Contacting Sweepster

If you have any questions about information in this manual or need to order parts, please call, write, fax or e-mail SWEEPSTER.

Sweepster
2800 North Zeeb Road
Dexter, Michigan 48130
Phone: (734)-996-9116 - (800)-456-7100
Fax: (734) 996-9014
e-mail: sweepster@paladinbrands.com

For help with installation, operation or maintenance procedures, contact our Technical Service Department. Direct product questions and parts orders to our Sales Department.

When ordering parts or accessories, be prepared to give the following information:

- Sweeper model, serial number and date of purchase
- Prime mover, make and model
- Part number, description and quantity

Terms Used in Manual

Right-hand, left-hand, front and rear are determined from the operator's perspective (either the operator's seat or standing behind a walk-behind unit), facing forward in the normal operating position.

Warranty

To validate the warranty for this unit, fill out the warranty card or warranty pages located in the back of this manual. Then send this information to SWEEPSTER.

DANGER!



THIS STATEMENT IS USED WHERE SERIOUS INJURY OR DEATH WILL RESULT IF THE INSTRUCTIONS ARE NOT FOLLOWED PROPERLY.

WARNING!



THIS STATEMENT IS USED WHERE SERIOUS INJURY OR DEATH COULD RESULT IF THE INSTRUCTIONS ARE NOT FOLLOWED PROPERLY.

CAUTION!



THIS STATEMENT IS USED WHERE MINOR INJURY COULD RESULT IF THE INSTRUCTIONS ARE NOT FOLLOWED PROPERLY.

NOTICE!

THIS STATEMENT IS USED WHERE EQUIPMENT OR PROPERTY DAMAGE COULD RESULT IF THE INSTRUCTIONS ARE NOT FOLLOWED PROPERLY.



THIS SYMBOL BY ITSELF OR USED WITH A SAFETY SIGNAL WORD THROUGHOUT THIS MANUAL IS USED TO CALL YOUR ATTENTION TO INSTRUCTIONS INVOLVING YOUR PERSONAL SAFETY OR THE SAFETY OF OTHERS. FAILURE TO FOLLOW THESE INSTRUCTIONS CAN RESULT IN INJURY OR DEATH.

GENERAL SAFETY PRECAUTIONS

WARNING!



READ MANUAL PRIOR TO INSTALL

Improper installation, operation, or maintenance of this equipment could result in serious injury or death. Operators and maintenance personnel should read this manual as well as all manuals related to this equipment and the prime mover thoroughly before beginning installation, operation, or maintenance. **FOLLOW ALL SAFETY INSTRUCTIONS IN THIS MANUAL AND THE PRIME MOVERS MANUAL.**

WARNING!



READ AND UNDERSTAND ALL SAFETY STATEMENTS

Read all safety decals and safety statements in all manuals prior to operating or working on this equipment. Know and obey all OSHA regulations, local laws and other professional guidelines for your operation. Know and follow good work practices when assembling, maintaining, repairing, mounting, removing or operating this equipment.



KNOW YOUR EQUIPMENT

Know your equipment's capabilities, dimensions and operations before operating. Visually inspect your equipment before you start, and never operate equipment that is not in proper working order with all safety devices intact. Check all hardware to assure it is tight. Make certain that all locking pins, latches, and connection devices are properly installed and secured. Remove and replace any damaged, fatigued or excessively worn parts. Make certain all safety decals are in place and are legible. Keep decals clean, and replace them if they become worn and hard to read.

GENERAL SAFETY PRECAUTIONS

WARNING!



PROTECT AGAINST FLYING DEBRIS

Always wear proper safety glasses, goggles or a face shield when driving pins in or out or when operation causes dust, flying debris, or any other hazardous material.

WARNING!



LOWER OR SUPPORT RAISED EQUIPMENT

Do not work under raised booms without supporting them. Do not use support material made of concrete blocks, logs, buckets, barrels or any other material that could suddenly collapse or shift positions. Make sure support material is solid, not decayed, warped, twisted, or tapered. Lower booms to ground level or onto blocks. Lower booms and attachments to the ground before leaving the cab or operator's station.

WARNING!



USE CARE WITH HYDRAULIC FLUID PRESSURE

Hydraulic fluid under pressure can penetrate the skin and cause serious injury or death. Hydraulic leaks under pressure may not be visible. Before connecting or disconnecting hydraulic hoses, read your prime movers operator's manual for detailed instructions on connecting and disconnecting hydraulic hoses or fittings.

- Keep unprotected body parts, such as face, eyes, and arms as far away as possible from a suspected leak. Flesh injected with hydraulic fluid may develop gangrene or other permanent disabilities.
- If injured by injected fluid, see a doctor at once. If your doctor is not familiar with this type of injury, ask him to research immediately to determine proper treatment.

GENERAL SAFETY PRECAUTIONS CONTINUED

- Wear safety glasses, protective clothing, and use a sound piece of cardboard or wood when searching for hydraulic leaks.
**DO NOT USE YOUR HANDS!
SEE ILLUSTRATION.**

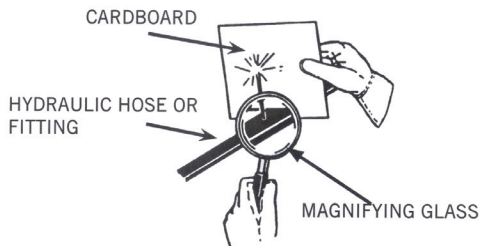

WARNING!



DO NOT MODIFY MACHINE OR ATTACHMENTS

Modifications may weaken the integrity of the attachment and may impair the function, safety, life and performance of the attachment. When making repairs, use only the manufacturer's genuine parts, following authorized instructions. Other parts may be substandard in fit and quality. Never modify any ROPS (Roll Over Protection System) equipment or device. Any modifications must be authorized in writing by the manufacturer.

WARNING!



SAFELY MAINTAIN AND REPAIR EQUIPMENT

- Do not wear loose clothing, or any accessories that can catch in moving parts. If you have long hair, cover or secure it so that it does not become entangled in the equipment.
- Work on a level surface in a well-lit area.
- Use properly grounded electrical outlets and tools.
- Use the correct tool for the job at hand. Make sure they are in good condition for the task required.

GENERAL SAFETY PRECAUTIONS CONTINUED

- Wear the protective clothing equipment specified by the tool manufacturer.

WARNING!



SAFELY OPERATE EQUIPMENT

Do not operate equipment until you are completely trained by a qualified operator in how to use the controls, know its capabilities, dimensions, and all safety requirements. See your prime movers manual for these instructions.

- Keep all step plates, grab bars, pedals, and controls free of dirt, grease, debris, and oil.
- Never allow anyone to be around the equipment when it is operating.
- Do not allow riders on the attachment or the prime mover.
- Do not operate the equipment from anywhere other than the correct operators position.
- Never leave equipment unattended with the engine running or with this attachment in a raise position.
- Do not alter or remove any safety feature from the prime mover or this attachment.
- Know your work site safety rules as well as traffic rules and flow. When in doubt on any safety issue, contact your supervisor or safety coordinator for an explanation.

WARNING!



EXPOSURE TO RESPIRABLE CRYSTALLINE SILICA DUST ALONG WITH OTHER HAZARDOUS DUSTS MAY CAUSE SERIOUS OR FATAL RESPIRATORY DISEASE.

It is recommended to use dust suppression, dust collection and if necessary personal protective equipment during the operation of any attachment that may cause high levels of dust.

SAFETY SIGNS & LABELS

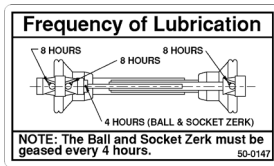

1. 50-0147

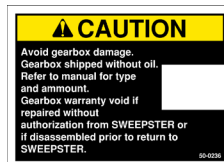

3. 50-0236

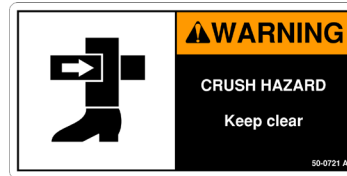

4. 50-0721

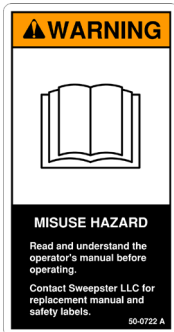

5. 50-0722



2. 50-0115



6. 50-0726



7. 41043

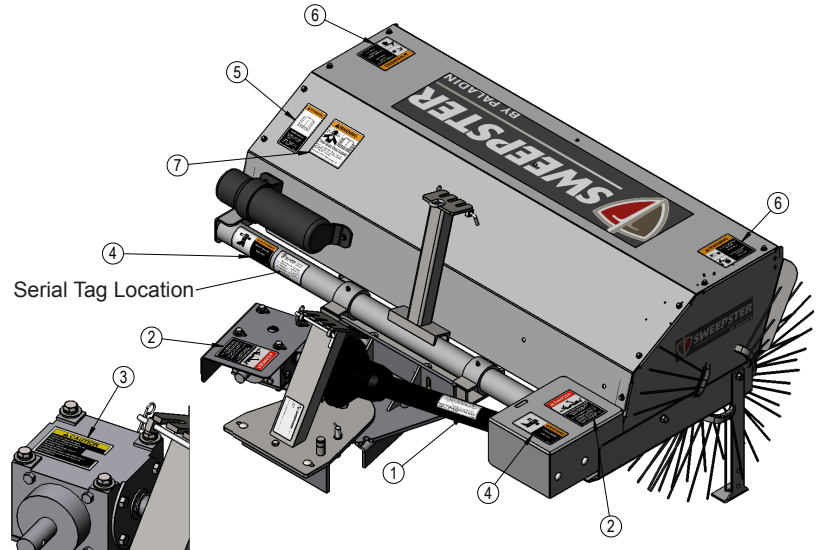

Item	Part	Qty	Description
1.	50-0147	1	Decal, Frequency of Lube, Weasler
2.	50-0115	2	Decal, Danger, Rotary Driveline
3.	50-0236	1	Decal, Gearbox, Hubcity, Check Oil
4.	50-0721	2	Decal, Warning, Crush point
5.	50-0722	1	Decal, Warning, Misuse Hazard
6.	50-0726	2	Decal, Warning, Flying Objects & Entanglement
7.	41043	1	Decal, Warning, Hazardous dust

SAFETY SIGNS & LABELS

There are several specific signs on this sweeper. The exact location of the hazards and description of the hazards are reviewed.

Placement or replacement of Safety Signs

- Clean the area of application with nonflammable solvent, and then wash the same area with soap and water.
- Allow the surface to fully dry.
- Remove the backing from the safety sign, exposing the adhesive surface.
- Apply the safety sign to the position shown in the diagram above and smooth out any bubbles.

Instructions

- Keep all safety signs clean and legible.
- Replace all missing, illegible, or damaged safety signs.
- Replacement parts, for parts with safety signs attached, must also have safety signs attached.
- Safety signs are available, free of charge, from your dealer.

INSTALLATION

Mounting Assembly

Install the mounting assembly (figure 1) on the tractor by the following instructions enclosed with those parts. Then proceed to Drive Assembly or Brush Head Assembly if your sweeper has a mounting assembly that includes a gearbox.

Drive Assembly

NOTE: Some mounting assemblies include a gearbox. Skip to Installation: Brush Head Assembly if this applies to your sweeper.

1. Position the drive assembly (figure 1) in front of the mounting assembly with the gearbox up.
2. Place the rear of the drive assembly on the front of the mounting assembly. Install a 3/8-16 x 1 1/2 inch cap screw, flat washer, lock washer and nut in the center hole (figure 1), but do not tighten the hardware completely.
3. Install 2, 3/8-16 x 1 1/2 inch carriage bolts, flat washers, lock washers and nuts in the outer holes, but do not tighten the hardware.

NOTE: If the mounting assembly includes angles and an input shield, place angles on the holes before installing hardware.

4. Connect the input driveline to the tractor and to the gearbox on the drive assembly. Follow instructions included with the mounting assembly.
5. Tighten the cap screw, flat washer, lock washer and nut.
6. Units with input drive shield - Place the input drive shield (figure 2) over the input driveline. Attach angle brackets to the input driveline shield. To make installation easier, put the washer, lock washer and nut toward the outside of the shield.

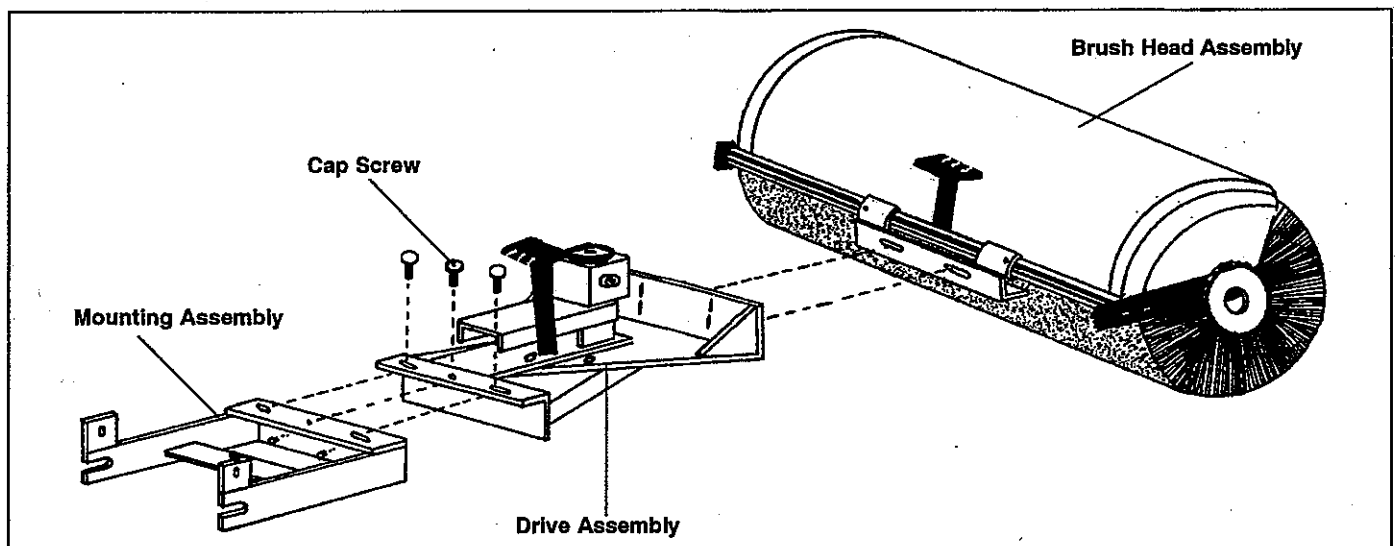

figure 1

INSTALLATION

Brush Head Assembly



figure 2

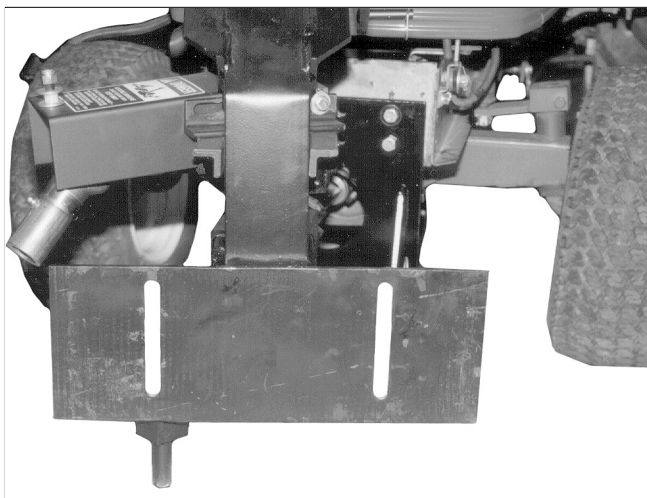

figure 3

1. After installing the mounting and drive assemblies, position the brush head assembly (figure 1) in front of the drive assembly.
2. Fasten the brush head assembly to the drive assembly using 2, 1/2-13 x 1 1/2 inch carriage bolts, flat washers, lock washers and nuts. Be sure to position the hardware as high as possible in the slots (figure 2).
3. Connect the output drive shaft to the gearbox shaft and to sprocket on the right-hand side of the brush head assembly. Tighten universal joint set screws.
 - If the sweeper has a telescoping drive shaft, it may need to be cut to length. Be sure to cut the same amount off both halves.
 - If the sweeper has a rectangular drive shaft and it is too long, shorten it by loosening the set screw on the universal joint mounted to the drive assembly gearbox and then sliding the drive shaft in.
4. Units with rectangular drive shaft - Install the output driveline shield (figure 2).
 - a. Place a washer and plastic bushing on the bolt welded to the output driveline shield. Place a washer and plastic bushing on the bolt welded to the gearbox output shield (figure 2).
 - b. Insert the bolt on the output driveline shield through the hole drilled in the chain shield. Insert the bolt on the gearbox output shield through the slot on the output driveline shield.
 - c. Place a washer and lock nut on both bolts; tighten.

NOTE: Do not over tighten lock nuts. The shield must be able to slide back and forth when the brush head is lowered and raised.

INSTALLATION

Spring-Chain Assembly, Transport Chain, Lift Cable

Follow the instructions that match your sweeper.

Spring-Chain Assembly & Transport Chain

Refer to figures 1 and 2.

1. Connect 2, 26-link chains and 2 springs to form a loop.
2. Place chains in the outside slots in the drive assembly upright and in the brush head assembly upright.
3. Place the 36-link transport chain in the center slot in the drive assembly and in the brush head assembly upright.
4. Slide a pin in the holes under the drive assembly upright and a pin in the holes under the brush head assembly. Insert a hairpin clip in each pin.

Spring-Chain Assembly & Lift Cable

Refer to figures 3 & 4.

1. Connect 2, 26-link chains and 2 springs to form a loop.
2. Place chains in the outside slots in the drive assembly upright and in the brush head assembly upright.
3. Route 1 end of the lift cable through the chain link welded to the brush head assembly upright. Loop the loose end around and secure it with a cable clamp (figure 5).

CAUTION!



INSTALL CABLE CLAMPS AS SHOWN IN FIGURE 5; otherwise; the cable could slip, possibly damaging the sweeper or injuring the operator.

4. Loop the other end through the link on the drive assembly upright; secure it with a cable clamp.
5. Hook up the electric lift system or optional hydraulic lift system.



figure 1

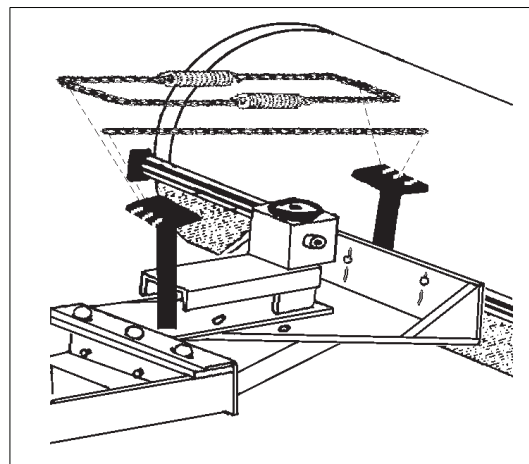

figure 2



figure 3

INSTALLATION

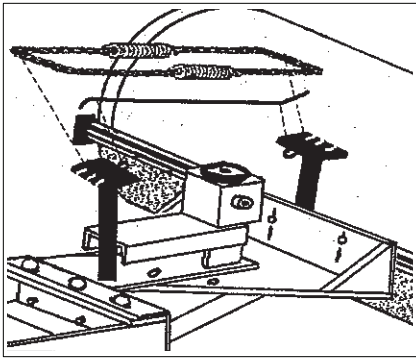

figure 4

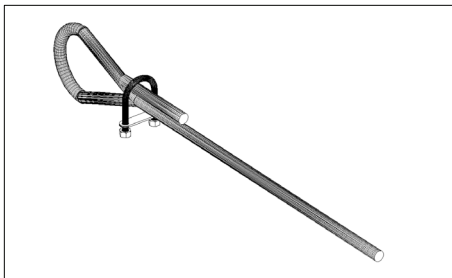

figure 5

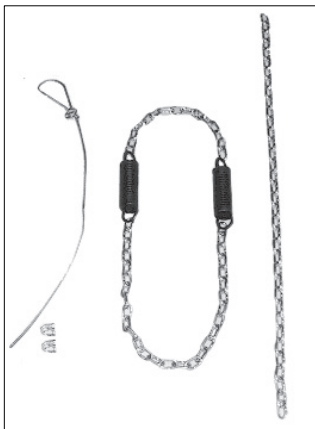

figure 6

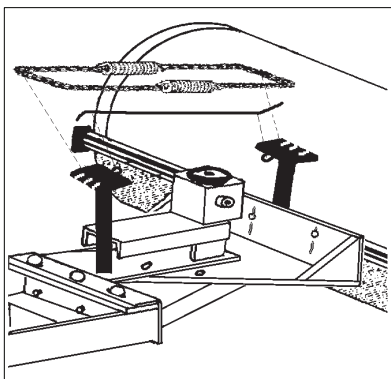

figure 7

6. Raise the brush head assembly using the lift system. If the brush head assembly raises 4 inches (101mm) off the ground, the lift cable is properly adjusted; otherwise, go to the next step.

7. Adjust the cable.

- If the brush head assembly does not raise enough, decrease the amount of cable between the uprights.
- If the brush head assembly raises too much, increase the amount of cable between the uprights.

Spring-Chain Assembly, Transport Chain & Lift Cable

Refer to figures 6 & 7.

1. Connect 2, 26-link chains and 2 springs to form a loop.
2. Place chains in the outside slots in the drive assembly upright and in the brush head assembly upright.
3. Route 1 end of the lift cable through the chain link welded to the brush head assembly upright. Loop the loose end around and secure it with a cable clamp (figure 5).

CAUTION!



INSTALL CABLE CLAMPS AS

SHOWN IN FIGURE 5; otherwise; the cable could slip, possibly damaging the sweeper or injuring the operator.

4. Loop the other end through the link on the drive assembly upright; secure it with a cable clamp.
5. Place the 36-link transport chain in the center slot in the drive assembly and in the brush head assembly upright.
6. Slide a pin in the holes under the drive assembly upright and a pin in the holes under the brush head assembly. Insert a hairpin clip in each pin.
7. Hook up the electric lift system or optional hydraulic lift system.

INSTALLATION

8. Raise the brush head assembly using the lift system. If the brush head assembly raises 4 inches (101mm) off the ground, the lift cable is properly adjusted; otherwise, go to the next step.

9. Adjust the cable.

- If the brush head assembly does not raise enough, decrease the amount of cable between the uprights.
- If the brush head assembly raises too much, increase the amount of cable between the uprights.



figure 1

Spring Chain Assemblies & Lift Cable

Refer to figures 1 & 2.

1. Attach a spring to 1 end of each chain.
2. Hook the springs on the drive assembly upright.
3. Place chains on the brush head assembly upright using the outside slots. Slide a pin in the holes under the drive assembly upright to secure the spring-chain assemblies; insert a hairpin clip in the pin.
4. Route 1 end of the lift cable through the chain link welded to the brush head assembly upright. Loop the loose end around and secure it with a cable clamp (figure 3).

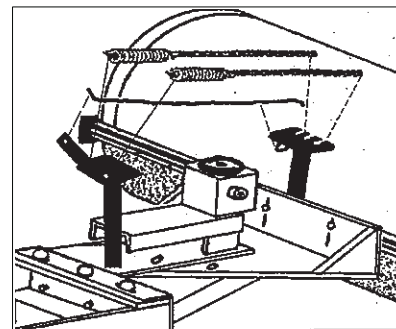

figure 2

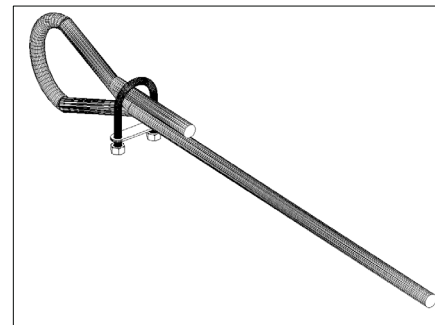

figure 3

CAUTION! **INSTALL CABLE CLAMPS AS SHOWN IN FIGURE 5;** otherwise; the cable could slip, possibly damaging the sweeper or injuring the operator.



5. Loop the other end through the link on the drive assembly upright; secure it with a cable clamp.
6. Hook up the electric lift system or optional hydraulic lift system.
7. Raise the brush head assembly using the lift system. If the brush head assembly raises 4 inches (101mm) off the ground, the lift cable is properly adjusted; otherwise, go to the next step.

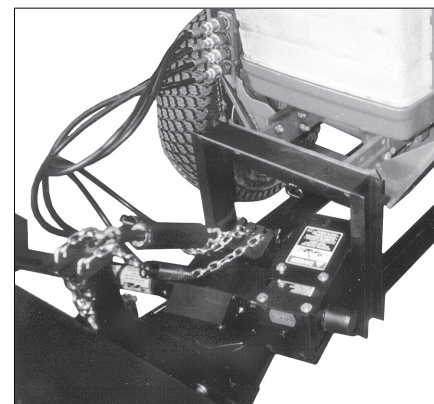

figure 4

INSTALLATION



figure 5

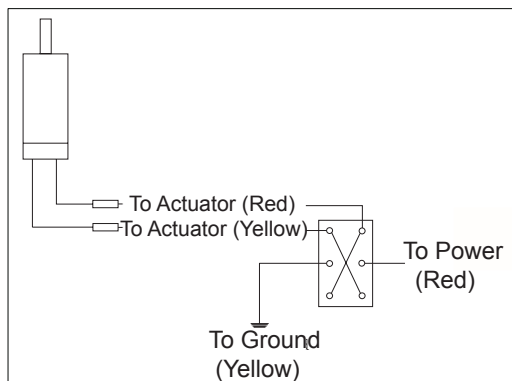

figure 6

4. Place a shackle on the rod end of the cylinder; then, attach the shackle to the brush frame upright.
5. Place a shackle on the barrel end of the cylinder and attach the chain to the shackle. Then, attach the chain to the center slot in the drive mounting assembly upright.
6. Connect quick coupler fittings to the front remote hydraulic outlets on the tractor.
7. Completely collapse the cylinder to check for adjustment.
 - If the brush head assembly lifts 4 inches (101mm) off the ground, the hydraulic lift is properly adjusted.
 - If the brush head assembly does not lift 4 inches (101mm) off the ground, adjust the chain. To raise the brush head assembly more, shorten the chain length between the cylinder and upright. To lower the brush head assembly, add to the chain length.

8. Adjust the cable.

- If the brush head assembly does not raise enough, decrease the amount of cable between the uprights.
- If the brush head assembly raises too much, increase the amount of cable between the uprights.

Spring-Chain Assembly & Standard Hydraulic Lift

Figure 4 shows assemblies fully installed.

1. Connect 2, 26-link chains and 2 springs to form a loop (figure 5).
2. Place chains in the outside slots in the drive assembly upright and in the brush head assembly upright.
3. Attach adapter fittings to both cylinder ports, and install elbow fittings on adapter fittings. Then, attach hoses to the elbow fittings and install quick coupler fittings on the hoses.

Electric Lift System

NOTE: Sweepers for commercial turf tractors and those with the hydraulic lift option do not use an electric lift system.

1. Locate a convenient, open area on the tractor dash to mount the lift switch.

NOTICE! **AVOID DAMAGE TO THE PRIME MOVER.** Before drilling, check behind the tractor dash to make sure that you will not drill into any wires or other objects.

2. Use a center punch to mark the lift switch location. Drill a pilot hole with a 1/4 inch bit; then, drill the finish hole with a 1/2 inch bit.
3. Insert the switch and secure it with a nut.
4. Route the control wires and connector to the front of the tractor. If necessary, strap or tape wires to the tractor frame to prevent them from hanging down.

INSTALLATION / ADJUSTMENTS

NOTICE! **AVOID WIRE DAMAGE.** Keep wires away from hot and/or moving parts.

5. Connect the red wire to the tractor power supply. Connect the yellow wire to a good ground, preferably the battery ground or tractor frame (figure 6).

NOTICE! **AVOID DAMAGE TO THE ELECTRIC LIFT SYSTEM.** Add a 13-amp, 12-volt fuse in line if the power supply is not fused.

6. Connect the wires from the lift switch to the actuator.

NOTE: If it is necessary to replace a wire, use a 14-gauge or heavier wire.

Leveling

Level the sweeper after installation and before each use for even brush wear and efficient sweeping.

1. Drive the sweeper to a level, paved area.
2. Lower the brush head assembly into the sweeping position. Make sure the weight of the brush head assembly is on the spring-chain assemblies and the brush just touches the ground.
3. Level the drive assembly using a level (figure 1).
 - If the front of the drive assembly is high, turn the leveling screws out (to the left) to lower it.
 - If the front of the drive assembly is low, turn the leveling screws out (to the right) to raise it.

See figure 2 for leveling screw locations.

4. With the brush head assembly in the straight position, measure from each end of the brush frame to the ground.
5. Compare measurements.
 - If they are not equal, slide the low side of the brush head assembly up in the slots on the drive assembly. Repeat steps 4 and 5 until

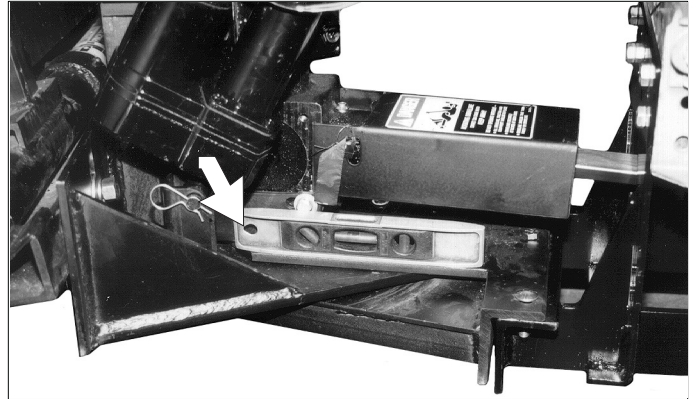

figure 1

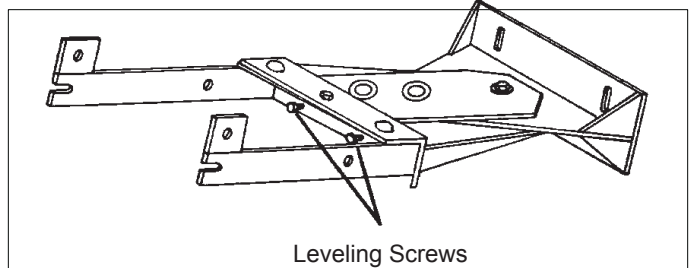

figure 2

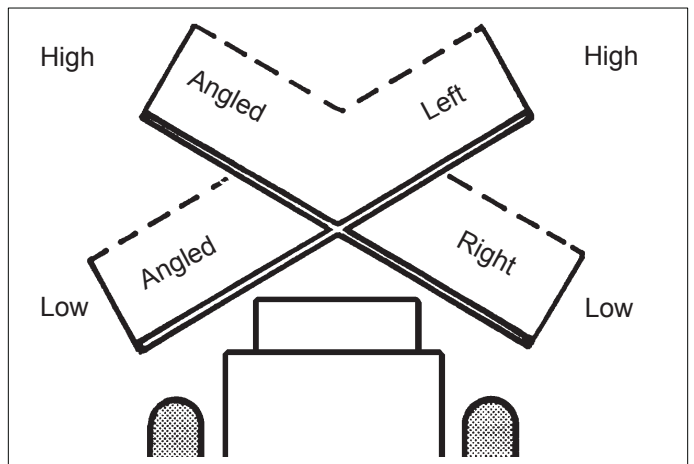

figure 3

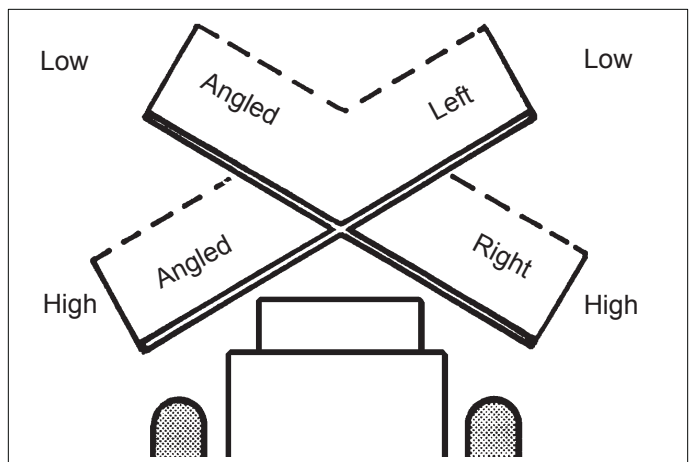

figure 4

ADJUSTMENTS

the measurements are equal. Tighten the hardware.

- If they are equal, go to step 6 (2-way sweepers) or the sweeper is level (1-way sweepers).
6. 2-way sweepers only - Swing the brush head assembly to the right. Measure from each end of the brush frame to the ground. Then, swing the brush head assembly to the left. Measure from each end of the brush frame to the ground.
- If all 4 measurements are the same, the brush head assembly is level.
 - If the measurements are not equal, refer to figures 3 and 4 for adjustments.

Repeat step 6 until the brush head assembly is level.

Brush Pattern

A properly adjusted brush offers the best sweeper performance. To check brush pattern:

1. Move the sweeper to a dusty, flat surface.
2. Set the prime mover's parking brake and leave the engine running.
3. Start the sweeper at a slow speed; then, lower it so bristle tips touch the ground. Run the sweeper in a stationary position for 10-30 seconds.
4. Raise the sweeper and back away; switch off the sweeper and engine and remove the key. The brush pattern left in the dust should be 2-3 inches (51-76mm) wide, running the length of the brush. Compare the swept area with figure 5.
5. Adjust the brush pattern as necessary.
 - a. Raise the brush head assembly with the electric lift system, optional hydraulic lift system or manually.

WARNING! AVOID SERIOUS INJURY OR DEATH. Do not allow anyone to go near or touch the brush head assembly while the sweeper is

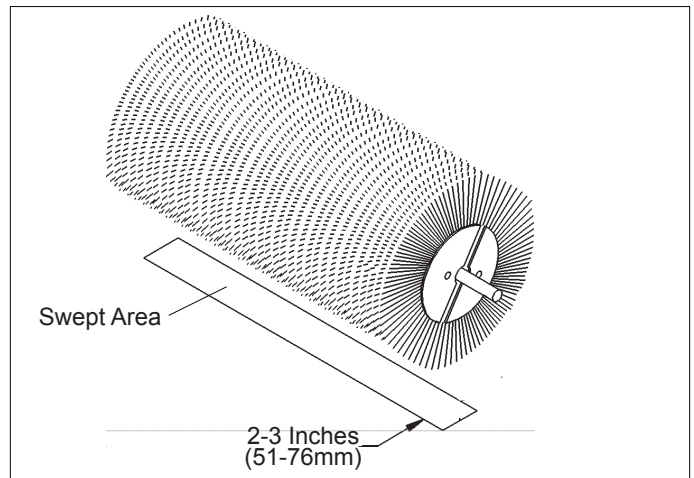

figure 5

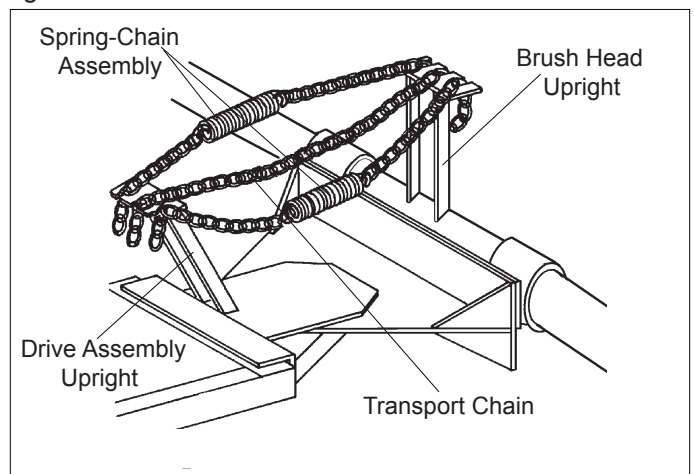

figure 6

running. Always stop the sweeper, shut off the prime mover engine and remove the key first.

- b. Adjust the spring-chain assembly (figure 6).
 - If the pattern is too wide, decrease the number of links between the uprights.
 - If the pattern is too narrow, increase the number of links between the uprights.

Transport Chain

The transport chain supports the weight of the brush head during transport between work sites.

1. Raise the sweeper.
2. Tighten the transport chain (figure 6)
3. Lower the sweeper so the transport chain supports the weight of the sweeper.

OPERATION

Before each use

Perform daily maintenance as indicated in Maintenance: Schedule.

Run the prime mover and sweeper at a slow idle. Check for loose hardware or other problems and make corrections, if necessary, before using the sweeper.

WARNING! **AVOID SERIOUS INJURY.** Check for objects that could harm the operator or others if thrown by the sweeper. Remove items before sweeping.



Observe wind direction. Sweeping with the wind makes sweeping more effective and helps keep debris off the operator.

Directing Debris

Direct debris by angling the brush head in that direction.

The terms *swing* and *angle* are used interchangeably.

Manual Angle Kit with Tube Links

1. Remove the lock pin from links.
2. Position the brush head at the desired angle, aligning holes in the inner and outer link.
3. Insert and close the lock pin.

Manual Angle Kit with T-Pin

1. Pull up on the T-pin.
2. Position the brush head at the desired angle.
3. Allow the pin to spring back into place.

Optional Hydraulic Angle Kit

1. Start the prime mover.
2. Position the brush head at the desired angle by using the valve control for swing function.

Sweeping

To sweep:

1. Manual Angle Kit Only - Swing the brush head assembly the direction that you want to direct debris.
2. Start the prime mover at idle.
3. Engage the PTO.
4. Hydraulic Angle Kit Only - Swing the brush head assembly the direction that you want to direct debris.
5. Lower the brush to the ground.
6. Increase prime mover engine rpm to sweeping speed.

NOTICE! **AVOID DAMAGE TO THE PRIME MOVER PTO.** Do not run the engine at speeds which make the PTO run faster than the recommended speed marked on the prime mover's tachometer.

7. Travel forward at 5mph (8kph) or less.

At the end of a run: slow engine and travel speeds, disengage the brush, raise the brush head assembly and then make the turn.

NOTICE! **AVOID SWEEPER DAMAGE.** When approaching obstacles, like utility poles or fire hydrants, slow engine and travels to avoid hitting these hazards.

OPERATION

Operating Tips

NOTICE! **AVOID SWEEPER DAMAGE.** Do not ram into piles. Use a dozer blade for this type of job.

Brush, Engine, & Travel Speeds

Vary brush, engine and travel speeds to match sweeping conditions.

Large areas

When sweeping a large area, such as a parking lot, make a path down the middle and sweep to both sides. This reduces the amount of debris that the sweeper must sweep in the next pass.

Snow

Fast brush speeds and slow travel speeds are needed to sweep snow effectively. Start at 3/4 throttle and the lowest gear of the prime mover. For wet and/or deep snow, increase to almost full throttle. This helps keep snow from packing up inside the brush hood.

In deep snow you may need to make multiple passes to get down to a clean surface.

To keep snow from blowing back onto a swept area, always sweep so the wind is at your back or so it follows the brush angle.

Dirt & Gravel

To keep dust at a minimum, plan sweeping for days when it is overcast and humid or after it has rained. Also, sweep so the wind blows at your back or in the direction the brush head is angled.

Low brush speeds and moderate travel speeds work best for cleaning debris from hard surfaces. Brush speeds that are too fast tend to raise dust because of the aggressive sweeper action.

To sweep gravel, use just enough brush speed to “roll” the gravel, not throw it.

Heavy Debris

Travel slowly - less than 5mph (8kph)

Sweep a path less than the full width of the sweeper.

Increase engine speed if debris becomes very heavy.

Thatch

Low brush speeds and low prime mover speeds do the best thatching job.

To prevent the brush from pulling itself into the ground, adjust the spring-chain assembly so the bristle tips barely touch the grass.

If the brush pulls into the grass and stalls while sweeping, use the lift to raise the brush. **Do not increase throttle to override a stall out.**

Use a combination of brush speeds and ground speeds that rolls up a neat windrow.

To keep thatch from blowing back onto a swept area, sweep with the wind at your back or in the direction the brush is angled.

STORAGE

Brushes

NOTICE!

DO NOT STORE THE SWEEPER WITH WEIGHT ON THE BRUSH. Weight will deform the bristles, destroying the sweeping effectiveness. To avoid this problem, place the sweeper on blocks or use optional stands.

Do not store polypropylene brushes in direct sunlight. The material can deteriorate and crumble before the bristles are worn out.

Keep polypropylene brush material away from intense heat or flame.

MAINTENANCE

Maintenance Record

Use this log to record maintenance performed on the sweeper.

Date	Maintenance Procedure Performed	Performed by	Comments

MAINTENANCE

Schedule

Part	Schedule			
	Daily	Every 8 Hours	Every 40 Hours	When Necessary
Brush Head Assembly - Check brush pattern; adjust as necessary. (See Adjustments: Brush Height) Level brush head. (See Adjustments: Leveling)		✓		
Drive Chain - Lubricate with oil or chain lubricant.			✓	
Drive Shaft - Lubricate universal joints with high-quality grease. Tighten universal joint set screws.		✓		
Electric Lift System - Inspect wires. Apply silicon spray to connections.			✓	
Gearbox - Check oil level; fill with SAE 80-90 weight oil. Inspect for oil leaks. Check end play in shafts. Clean shafts and vent plugs.			✓	
Hardware - Check for and tighten loose hardware.	✓			
Hydraulic Lift Option - Inspect hydraulic hoses and connections. Replace damaged or worn parts.			✓	
Mounting Assembly - Lubricate with high-quality grease.			✓	
Safety Signs - Clean to keep instructions readable.				✓
Swing Plate - Lubricate with high-quality grease.			✓	
Tractor Air Cleaner - Clean or replace according to instructions in tractor's owner's manual.				✓
V-Belt - Check tension. Replace ant worn belts.		✓		

General

For best performance, regularly maintain your sweeper. Carefully follow recommendations listed in this manual.

Lubricating Constant Velocity (CV) Drive Shaft

Lubricate with high-quality grease before starting work and after every 8 hours.

Clean and grease the drive shaft before each period of non-use.

To prevent freezing in winter, grease the shield tubes.

Lubricating Gearbox

After the first 100 operating hours, drain the oil and flush the gearbox with an approved, nonflammable, nontoxic solvent. Refill with oil.

Following the first oil change, oil after every 2,500 operating hours or 6 months, whichever comes first.

MAINTENANCE

Replacing Brush Sections

1. Remove the front bolt from inside the right-hand side of the brush frame. This allows you to remove the shield and right mounting bracket (figure 1).
2. Remove the rear screw from the right-hand side of the brush frame.
3. Remove the 2 bolts from inside the left-hand side of the brush frame (figure 2).
4. Pull the brush out of the brush frame.
5. Stand the brush on end and rest it on blocks.
6. Loosen screws on the retainer plate and take off the retainer halves (figure 3).
7. Remove old sections from the core.
8. Install new sections by doing the following:
 - a. Number the tubes on the core as 1, 2 and 3 (figure 4).
 - b. Slide the first section onto the core with the drive pins on both sides of tube 1. Make sure that drive pins (figure 5) face up.

NOTE: When using 1/2 poly - 1/2 wire sections, place a poly section first and last on the core to prevent damage to the hood, driveline and frame.

- c. Place the second section on the core with drive pins on both sides of tube 2. Be sure drive pins face down.
- d. Slide the third section onto the core with drive pins around tube 3. Be sure the drive pins face up.
- e. Slide sections on until the core is full, making sure to alternate the tubes used and the direction of the drive pins.

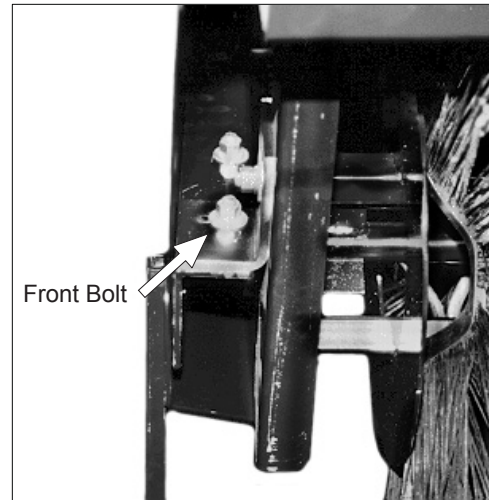

figure 1

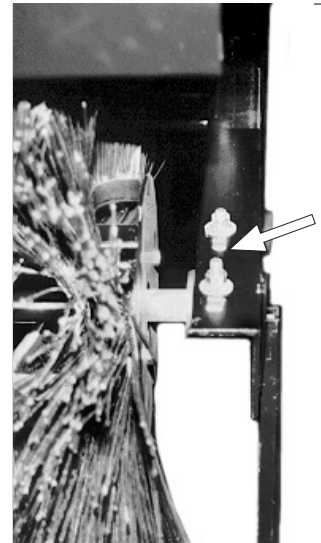

figure 2

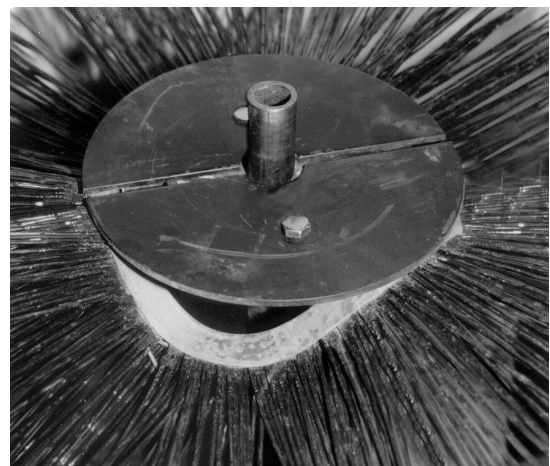

figure 3

MAINTENANCE

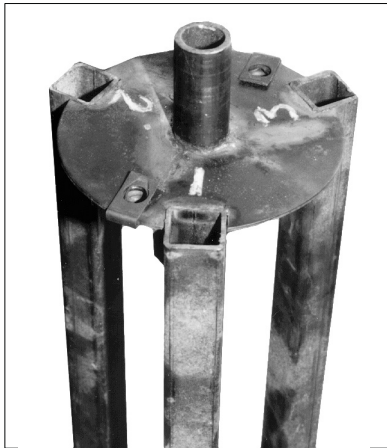

figure 4

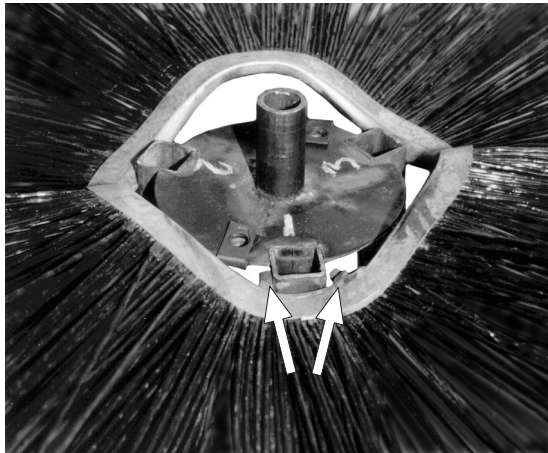

figure 5

9. Place the retainer halves on the brush and reinstall the screws.
10. Position the brush in front of the brush hood.
11. Reinstall the drive chain on the core sprocket.
12. Slide the brush into the left-hand side of the brush frame. Reinstall the hardware but do not tighten completely.
13. Slide the right-hand side of the brush into the brush frame. Reinstall the rear hardware but do not tighten.
14. Replace the shield and reinstall the front bolt.
15. Tighten the hardware on the left-hand side.
16. Pull the drive chain tight; then, tighten the hardware on the right-hand side.

Worn Section Standard				Reference Information	
Section OD, New	Ring ID	Section OD, Worn	Exposed Bristle, Worn	Bristle Length	Exposed Bristle, New
24	6.38	17	3.8	8.50	7.5
26	8.00	18	4.0	9.00	8.0
32	10.00	22	5.0	11.00	10.0
36	10.00	24	6.0	13.00	12.0
36	10.63	25	6.0	12.69	11.4
46	19.38	34	6.0	13.31	12.1

TROUBLESHOOTING

Brush Head Assembly

Problem	Possible Cause	Possible Solution
Brush rotates wrong direction	<u>Gearboxes with 3 shafts</u> - gearbox flipped	Remove gearbox, switch breather cap and plug, and remount gearbox
	<u>Gearboxes with 2 shafts</u> - incorrect gearbox	Contact SWEEPSTER for replacement
Brush head assembly “bounces” when sweeping	Brush pattern needs adjustment	Adjust; see Adjustments: Brush Pattern
	Ground speed too fast and/or brush speed too slow	Find correct combination of ground and brush speeds
	Core is bent	Replace core
Brush wears unevenly	Brush head assembly is not level	Level brush head; see Adjustments: Leveling
Brush wears very quickly	Brush pattern not adjusted correctly	Adjust brush pattern; see Adjustments: Brush Pattern
	Brush speeds too high	Use slower brush speeds
Drive chain falls off repeatedly	Core not riding on sprocket	Align core
	Not enough tension on chain	Slide core forward

Gearbox

Problem	Possible Cause	Possible Solution
Gearbox does not turn	Broken shaft or gear	Do not open a gearbox still under warranty; contact SWEEPSTER for replacement parts
Oil leaking from pinion housing, caps, cap screws or pipe plugs	Loose hardware	Retighten hardware or remove and coat with Loctite® before tightening; if necessary, replace gaskets
High internal operating temperature (above 200°F [93.33°C])	Damaged bearings	Replace bearings
	Oil level too low	Add oil
Excessive end play in shafts (.005 inches [1.3mm] or more) when couplings are removed	Worn bearings	Remove gaskets between caps and gear case; replace if necessary
Excessive backlash	Worn gears	Adjust gears; replace, if necessary

TROUBLESHOOTING

Constant Velocity (CV) Drive Shaft

Problem	Possible Cause	Possible Solution
End and/or inboard yoke ears spread	Drive shaft too long	Adjust drive shaft length; replace parts
	Axial forces too high - running above recommended rpm	Clean and grease profile tubes; replace parts; replace both tubes, if necessary
End yoke ears have pressure marks	Excessive bend angle when shaft rotates	Avoid running brush in raised position; switch off tractor PTO during cornering or when lifting the brush head; replace parts
End yoke bearing caps blued	Insufficient lubrication	Follow lubrication instructions; see Maintenance: Lubricating CV Drive Shaft; replace parts
Inboard yoke ears have pressure marks	Excessive bend angle when shaft rotates	Avoid running brush in raised position; switch off tractor PTO during cornering or when lifting the brush head; replace parts
	Drive shaft too long	Adjust drive shaft length
Inboard yoke bearing caps blued	Insufficient lubrication	Follow lubrication instructions; replace parts
Shield tube deformed and split on 1 side	Shield tube too short or no overlap at all when drive shaft is extended	Adjust shield tube length; replace parts
Shield tubes damaged	Shields contact components on tractor and/or sweeper	Allow more clearance; replace parts
Shield cone destroyed	Shield cone contacts components on tractor and/or sweeper	Allow more clearance; replace parts
Telescoping sections distorted	Overload caused by high starting and peak torques or blocking	Engage and disengage at idle; replace parts

Lift System

Problem	Possible Cause	Possible Solution
Electric lift does not lift	Disconnected wires	Check and connect wires
	Switch failure	Replace switch; replace actuator, if necessary
Hydraulic lift does not lift	Disconnected hoses	Check and connect hoses
	Hydraulic pump failure	Contact dealer for service

BRUSH HEAD ASSEMBLY

Item	Part	Qty	Description	Item	Part	Qty	Description
1.	01-0550	1	Core, 4 ft	30.	08-0006	2	Bearing, 1 Round, with Collar
	01-0209	1	Core, 5 ft	31.	08-0034	1	Bearing, 7/8 Hex, with Hole
	01-0640	1	Core, 6 ft	32.	08-0037	1	Bearing, 7/8 Hex, without Hub
2.	06-0238	1	Sprocket, 50B, 12 x 7/8 Hex	33.	11-1804	1	Plate, Retainer, Section, Set
3.	06-0275	1	Chain, #50, 88 Links, with Master	34.	11-3725-37	1	Shaft, Hex, 7/8 x 5, without Hole
4.	07-0018	1	Screw, HHC, Gr8, 3/8-16 x 1	35.	11-9604	1	Plate, Mounting, Shield
5.	07-0156	2	Washer, Flat, 1/2	36.	11-9605	1	Shield Drive, Core, Front
6.	07-0209	1	Clip, Hairpin, 16ga x 1 3/8	37.	11-9611	1	Shield, Brush, Side, Right
7.	07-0239	1	Pin, Spring, Lock, 3/16 x 1 1/4	38.	13-0011-1	1	Weld, Brush Frame, 1 Way, 4 ft Mordidge
8.	07-0240	2	Nut, Lock, Stamped, 5/16 x 18		13-0011-2	1	Weld, Brush Frame, 1 Way, 5 ft Mordidge
9.	07-1187	1	Screw, Set, Gr2, 1/4-28 x 1/4		11-9972-1	1	Weld, Brush Frame, 2 Way, 4 ft
10.	07-1709	1	Pin, Clevis, 1/4 x 4 1/2		11-9972-2	1	Weld, Brush Frame, 2 Way, 5 ft
11.	07-1716	10	Bolt, Carriage, 3/8-16 x 1		11-9972-3	1	Weld, Brush Frame, 2 Way, 6 ft
12.	07-1717	1	Bolt, Carriage, 3/8-16 x 1 1/4	39.	13-13457	1	Sheet, Side, Hood, Left
13.	07-1718	14	Washer, Lock, Split, 3/8	40.	13-13458	1	Sheet, Side, Hood, Right
14.	07-1762	2	Washer, Lock, Split, 1/2	41.	13-16976	1	Plate, Adjustment Stop
15.	07-1764	2	Nut, Hex, 1/2-13	42.	13-17083-4	1	Sheet, Hood, 4 ft
16.	07-1973	2	Screw, Cap, 5/16-18 x 1 1/4		13-17083-5	1	Sheet, Hood, 5 ft
17.	07-2952	12	Screw, HFH, CL10.9, M6-1 x 20		13-17083-6	1	Sheet, Hood, 6 ft
18.	07-3112	2	Fitting, Zerk, 1/4-28	43.	13-17119	1	Shield, Drive, Rear
19.	07-3273	8	Washer, Lock, Split, 5/16	44.	13-8936	2	Plate, Shipping, Stand
20.	07-3278	8	Nut, Hex, 5/16-18	45.	50-0115	1	Label, Danger, Rotating Driveline
21.	07-3279	9	Washer, Flat, 3/8	46.	50-0184	2	Label, Small, White, Sweepster
22.	07-3280	8	Bolt, Carriage, Gr5, 5/16-18 x 3/4	47.	50-0252	1	Label, Logo, Sweepster, White
23.	07-3617	12	Nut, Insert, M6 x 1, Hex	48.	50-0634	1	Label, Serial Number
24.	07-3654	14	Nut, Hex, 3/8-16	49.	50-0721	1	Label, Warning, Crush Hazard
25.	07-3699	2	Bolt, Carriage, 3/8-16 x 3/4	50.	50-0722	1	Label, Warning, Misuse Hazard
26.	07-3708	2	Bolt, Carriage, 1/2-13 x 1 1/2	51.	50-0726	2	Label, Warning, Flying Objects & Entanglement
27.	07-6889	1	Manual Holder				
28.	08-0003	3	Flange, Bearing, PBS, Only				
29.	08-0005	5	Flange, Bearing, 2 Hole				

Part	Qty	Description
01-0001C	1	Set, Section, 24, Poly, Conv, 4ft
01-0005C	1	Set, Section, 24, Wire, Conv, 4ft
01-0013C	1	Set, Section, 24, Combination, Conv, 4ft
01-0017C	1	Set, Section, 24, Poly, Conv, 5ft
01-0018C	1	Set, Section, 24, Wire, Conv, 5ft
01-0019C	1	Set, Section, 24, Combination, Conv, 5ft
01-0537C	1	Set, Section, 24, Poly, Conv, 6ft
01-0538C	1	Set, Section, 24, Wire, Conv, 6ft
01-0539C	1	Set, Section, 24, Combination, Conv, 6ft

BRUSH HEAD ASSEMBLY

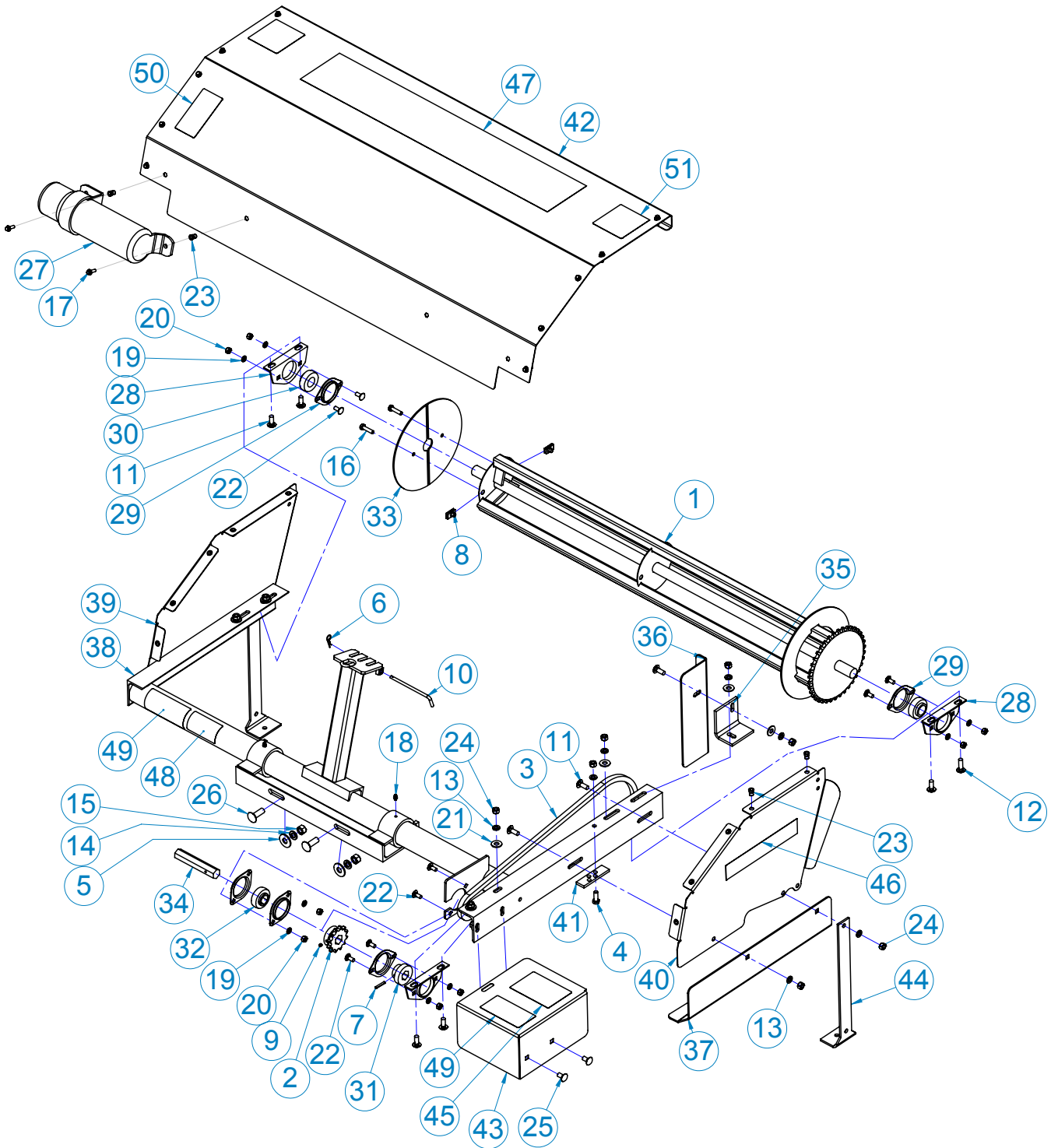

DRIVE ASSEMBLIES 1-WAY

Assemblies 11-1727 & 11-1728

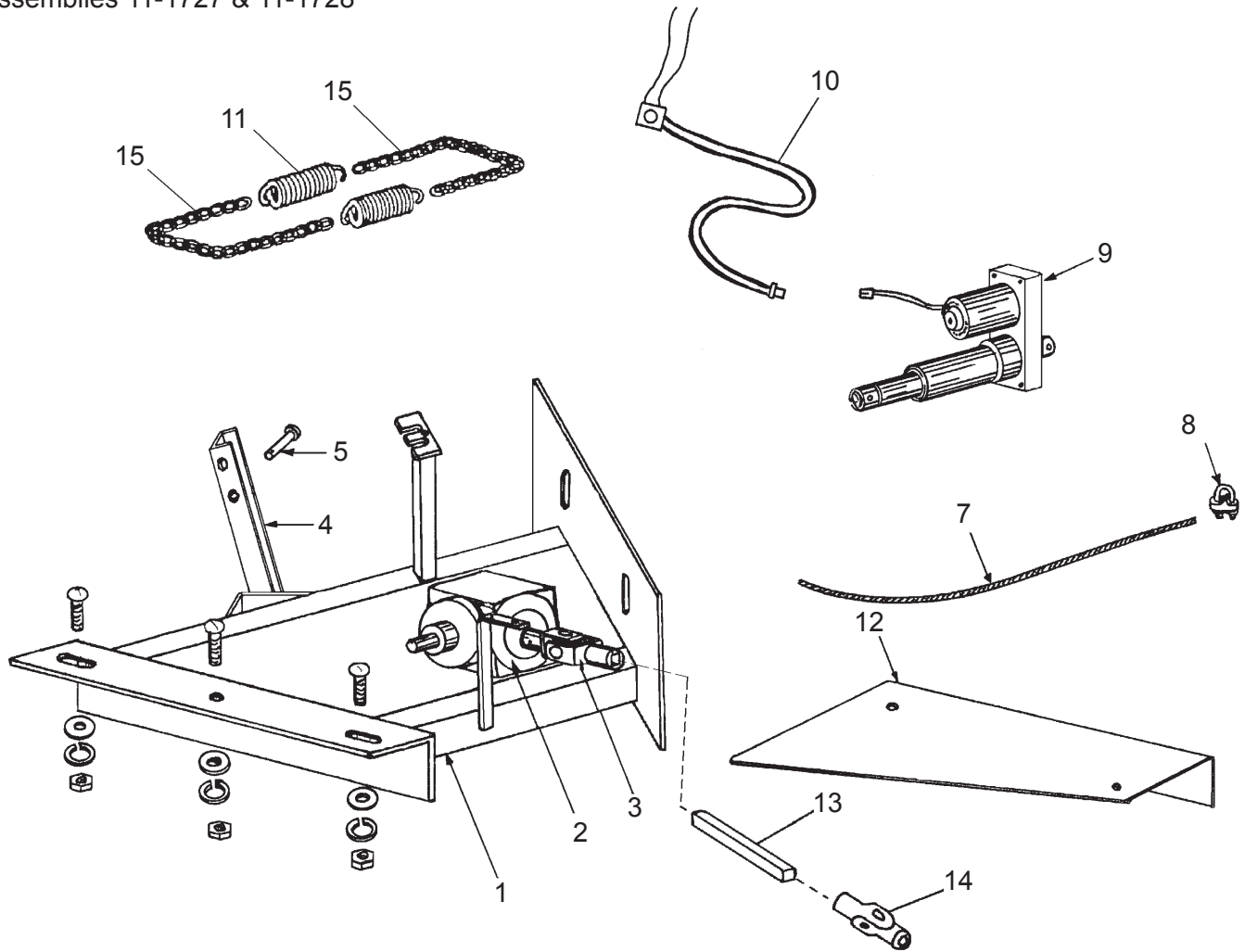

Item	Part	Qty	Description
1.	11-3001	1	Frame, Drive, 1-Way
2.	05-0003	1	Gearbox, Right-Hand, 7/8 Round-7/8 Round (11-1727)
	05-0004	1	Gearbox, Left-Hand, 3/4 Round-3/4 Round (11-1728)
3.	05-1076	1	U-Joint, H7, Rectangular, 3/4 Round
4.	11-1684	1	Arm, Lift
5.	07-0196	2	Pin, Clevis, 1/2 x 2
7.	11-7289	1	Cable, 3/16 x 32
8.	07-0214	2	Clamp, Cable, 3/16
9.	07-1660	1	Actuator, 450 lb
10.	11-1810	1	Wire Harness
11.	07-0237	2	Spring, Tension, 1-13/32 x 6
12.	11-1631	1	Shield, 1-Way
13.	11-1585	1	Shaft, Rectangular, 9
14.	05-0655	1	U-Joint, H7, Hex-Rectangular
15.	07-0314	2	Chain, 3/16, 15 Links

DRIVE ASSEMBLIES 1-WAY

Assemblies 11-17224 & 11-17229

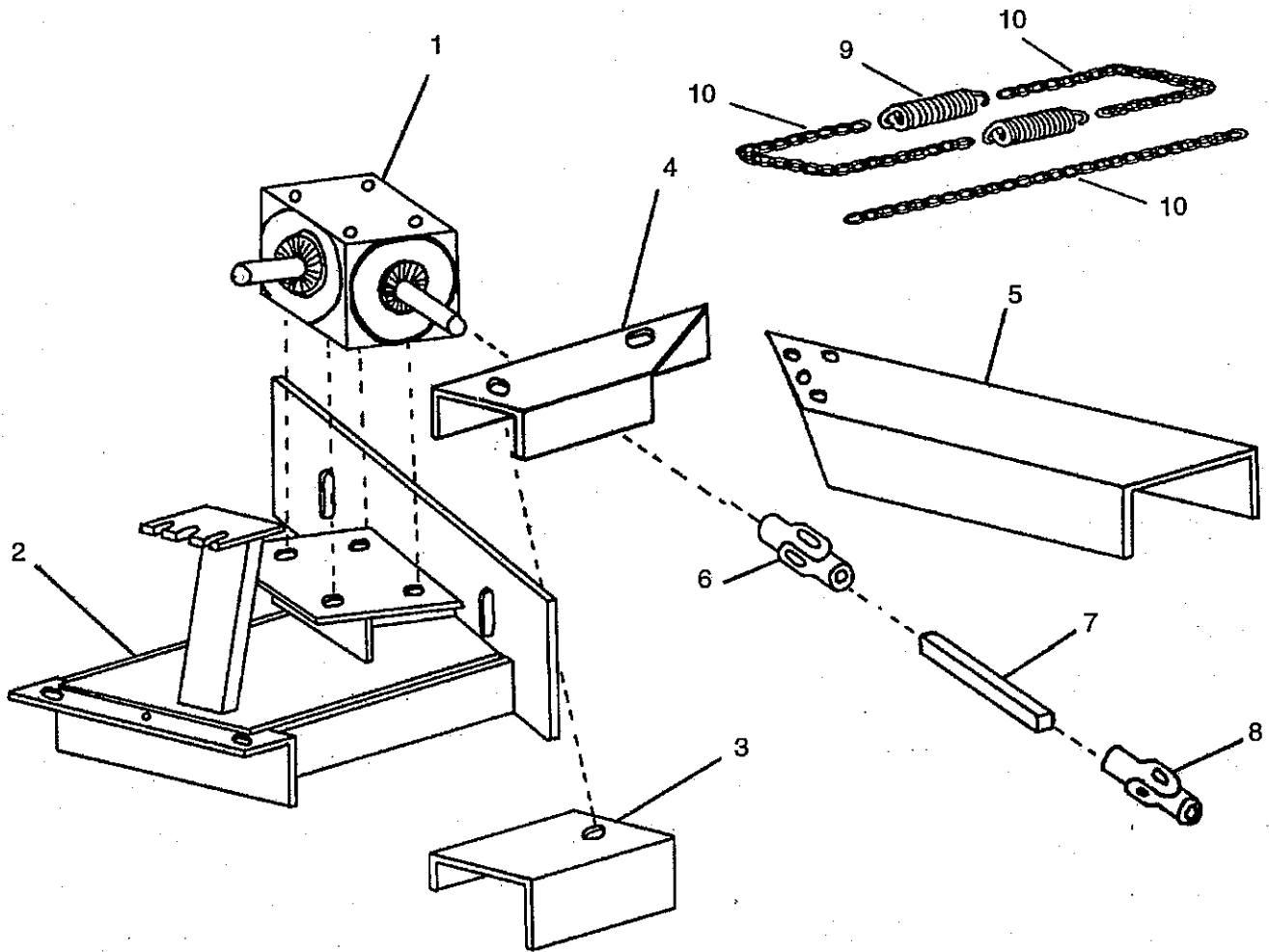

Item	Part	Qty	Description
1.	05-1113	1	Gearbox, 1:1, Left-Hand (11-17229)
	05-1114	1	Gearbox, 1:1, Right-Hand, (11-17224)
2.	11-9216	1	Frame, Drive, 1-Way
3.	13-2823	1	Shield, Drive, Extension, 1-Way
4.	11-9214	1	Shield, Drive, Input
5.	11-9215	1	Shield, Drive, Output
6.	05-0926	1	U-joint, H7, Rectangular, 1 Round
7.	11-1585	1	Shaft, Rectangular, 9
	11-1590	1	Shaft Rectangular, 6 1/2 (Moridge Units)
8.	05-0655	1	U-joint, H7, Hex, Rectangular
9.	07-0237	2	Spring, Tension, 1 13/32 x 6

DRIVE ASSEMBLIES 1-WAY

Item	Part	Qty	Description
1.	05-0656	1	U-Joint, H7, Rectangular, 7/8 Round, 3/16 Keyway
2.	05-0763	1	Fitting, Zerk, 1/4-28
3.	05-1145	1	Gearbox, 3:1, T-Style, 3-Shaft, Left-Hand/Right-Hand
4.	07-0156	1	Washer, Flat, 1/2
5.	07-0196	3	Pin, Clevis, 1/2 x 2
6.	07-0209	1	Clip, Hairpin, 16ga x 1 3/8
7.	07-0210	3	Clip, Hairpin, 14ga x 1 3/4
8.	07-0214	4	Clamp, Cable, 3/16
9.	07-0237	2	Spring, Tension, 1 13/32 x 6
10.	07-0387	2	Chain, 3/16, 26 Links
11.	07-0677	1	Key, 3/16 x 1 1/4
12.	07-1660	1	Actuator, 450 lb
13.	07-1709	1	Pin, Clevis, 1/4 x 4 1/2
14.	07-1714	3	Screw, Cap, 5/16-18 x 1
15.	07-1718	3	Washer, Lock, Split, 3/8
16.	07-1730	2	Bolt, Carriage, 3/8-16 x 1 1/2
17.	07-1762	1	Washer, Lock, Split, 1/2
18.	07-1764	1	Nut, Hex, 1/2-13
19.	07-1882	1	Screw, Set, 3/8-16 x 5/8, Cup Point
20.	07-3272	1	Nut, Hex, Jam, 3/8-16
21.	07-3273	5	Washer, Lock, Split, 5/16
22.	07-3275	5	Washer, Flat, 5/16
23.	07-3432	2	Screw, Cap, 1/4-20 x 3/4
24.	07-3436	2	Screw, Cap, 5/16-18 x 3/4
25.	07-3654	3	Nut, Hex, 3/8-16
26.	07-3655	1	Screw, Cap, 3/8-16 x 1 1/2
27.	07-3674	1	Screw, Cap, 1/2-13 x 2 3/4
28.	07-4032	2	Washer, Flat, 1/4
29.	07-4038	2	Washer, Lock, Split, 1/4
30.	07-4039	2	Nut, Hex, 1/4-20
31.	11-1631	1	Shield, Drive, 1-Way
32.	11-1684	1	Arm, 11, Pivot Hole, 21/32
33.	11-1810	1	Wire Harness
34.	11-1945	1	Tube, Round, 5/8 x 16ga x 1 3/4
35.	11-3001	1	Frame, Drive, 1-Way
36.	11-3257	1	Shield, Drive, 1-Way
37.	11-7289	1	Cable, 3/16 x 32
38.	13-0518	1	Key, 3/16 x 1
39.	50-0115	1	Label, Danger, Rotating Driveline
40.	50-0184	1	Label, Small, White, Logo
41.	50-0249	1	Label, Plate, Part Number, Date

DRIVE ASSEMBLIES 1-WAY

Assembly 11-17142

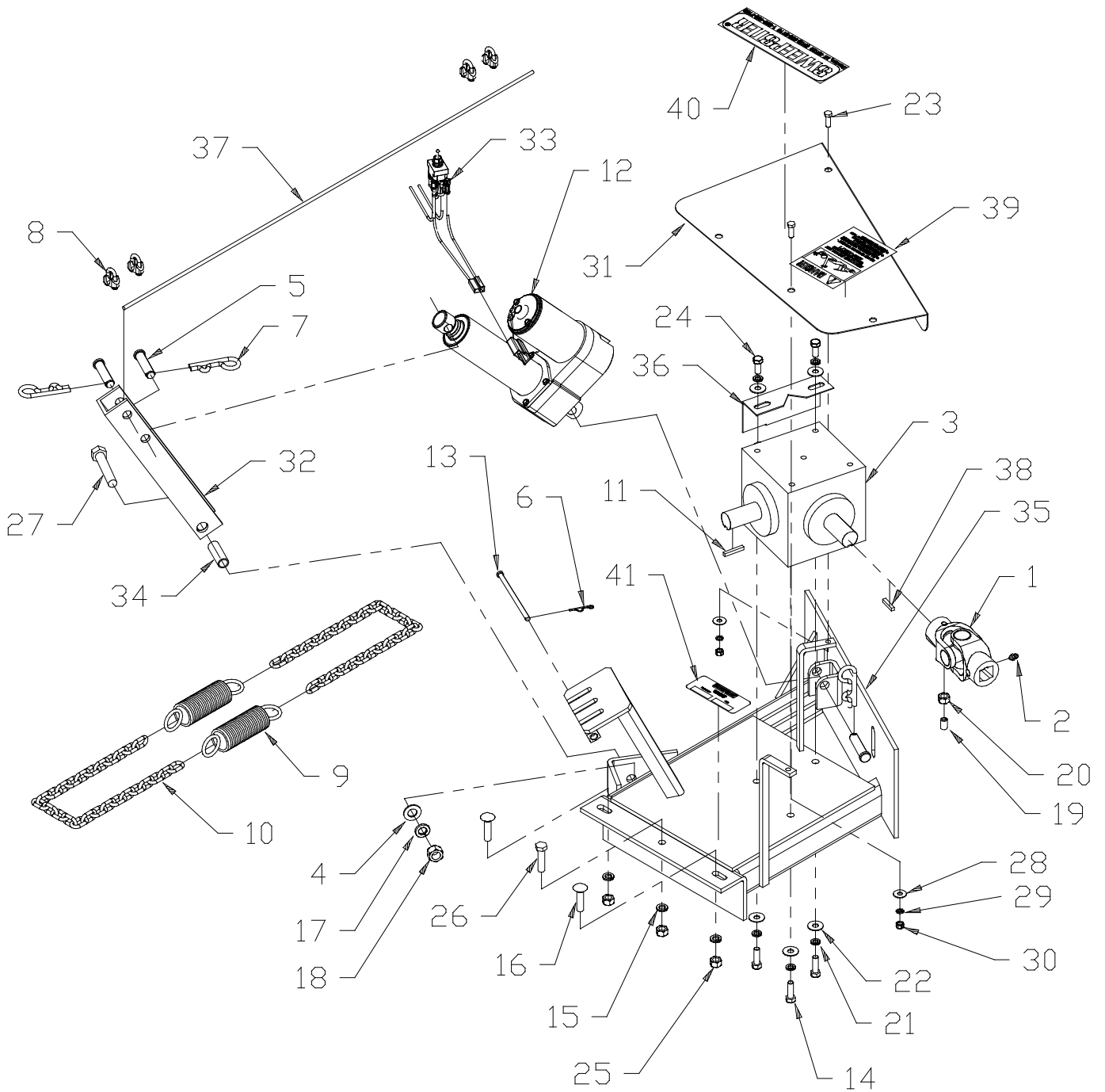

DRIVE ASSEMBLIES 1-WAY

Item	Part	Qty	Description
1.	03-0011	2	Hose, 1/4 x 36, 1W, 1/4MP
2.	03-0898	2	Fitting, Adapter, HP, 9/16MOR, 1/4FP
3.	03-1053	2	Fitting, Elbow, HP, 45°, 1/4MP, 1/4FPS
4.	03-1851	1	Cylinder, 1.75 x 4 x 9, 9/16 O-Ring (09/23/09 & Before)
	03-5719	1	Cylinder, 1.75 x .75 x 4, 3.5K (09/24/09 & After)
5.	05-0656	1	U-Joint, H7, Rectangular, 7/8 Round, 3/16 Keyway
6.	05-0763	1	Fitting, Zerk, 1/4-28
7.	05-1145	1	Gearbox, 3:1, T-Style, 3-Shaft, Left-Hand/Right-Hand
8.	07-0209	1	Clip, Hairpin, 16ga x 1 3/8
9.	07-0237	2	Spring, Tension, 1 13/32 x 6
10.	07-0387	3	Chain, 3/16, 26 Links
11.	07-1709	1	Pin, Clevis, 1/4 x 4 1/2
12.	07-1714	3	Screw, Cap, 5/16-18 x 1
13.	07-1718	3	Washer, Lock, Split, 3/8
14.	07-1730	2	Bolt, Carriage, 3/8-16 x 1 1/2
15.	07-1732	2	Shackle, Chain, 1/4, with Screw Pin
16.	07-1882	1	Screw, Set, 3/8-16 x 5/8, Cup Point
17.	07-3272	1	Nut, Hex, Jam, 3/8-16
18.	07-3273	5	Washer, Lock, Split, 5/16
19.	07-3275	5	Washer, Flat, 5/16
20.	07-3432	2	Screw, Cap, 1/4-20 x 3/4
21.	07-3436	2	Screw, Cap, 5/16-18 x 3/4
22.	07-3654	3	Nut, Hex, 3/8-16
23.	07-3655	1	Screw, Cap, 3/8-16 x 1 1/2
24.	07-4032	2	Washer, Flat, 1/4
25.	07-4038	2	Washer, Lock, Split, 1/4
26.	07-4039	2	Nut, Hex, 1/4-20
27.	11-1631	1	Shield, Drive, 1-Way
28.	11-3001	1	Frame, Drive, 1-Way
29.	11-3257	1	Shield, Drive, 1-Way
30.	13-0518	2	Key, 3/16 x 1
31.	50-0115	1	Label, Danger Rotating Driveline
32.	50-0184	1	Label, Small, White, Logo
33.	50-0249	1	Label, Plate, Part Number, Date

Replacement Parts for 03-5719:

46072 Seal Kit
114406 Cylinder Rod

DRIVE ASSEMBLIES 1-WAY

Assembly 11-17390

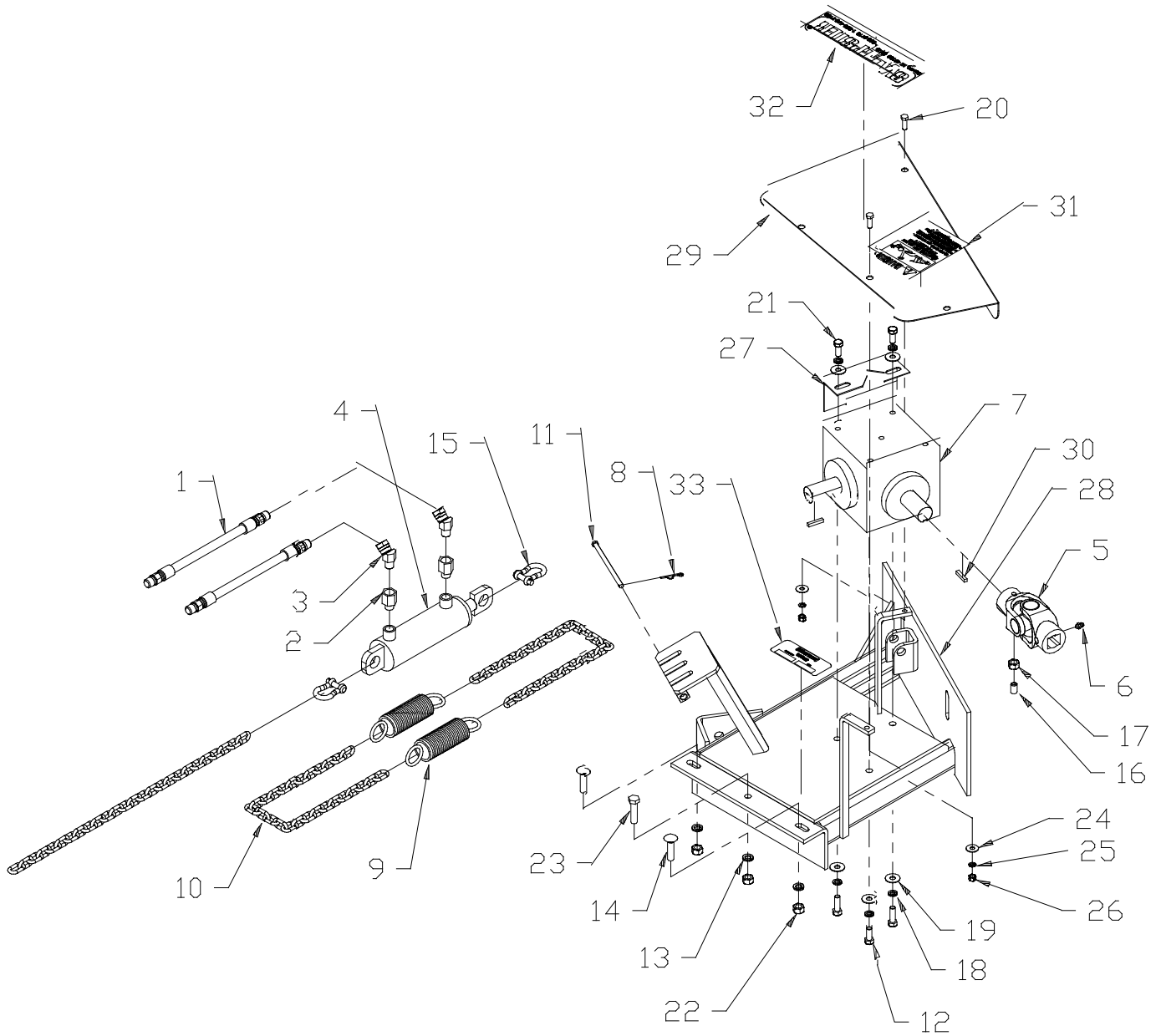

DRIVE ASSEMBLIES 1-WAY

Item	Part	Qty	Description
1.	05-0926	1	U-Joint, H7, Rectangular, 1 Round
2.	05-1112	1	Gearbox, 3:1, Left-Hand
3.	07-0209	1	Clip, Hairpin, 16ga x 1 3/8
4.	07-0223	1	Fitting, Zerk, Straight, NPT
5.	07-0237	2	Spring, Tension, 1-13/32 x 6
6.	07-0387	2	Chain, 3/16, 26 Links
7.	07-1709	1	Pin, Clevis, 1/4 x 4 1/2
8.	07-1714	3	Screw, Cap, 5/16-18 x 1
9.	07-1718	3	Washer, Lock, Split, 3/8
10.	07-1730	2	Bolt, Carriage, 3/8-16 x 1 1/2
11.	07-1759	1	Chain, 3/16, 36 Links
12.	07-1882	3	Screw, Set, 3/8-16 x 5/8, Cup Point
13.	07-3272	3	Nut, Hex, Jam, 3/8-16
14.	07-3273	5	Washer, Lock, Split, 5/16
15.	07-3275	5	Washer, Flat, 5/16
16.	07-3432	2	Screw, Cap, 1/4-20 x 3/4
17.	07-3436	2	Screw, Cap, 5/16-18 x 3/4
18.	07-3654	3	Nut, Hex, 3/8-16
19.	07-3655	1	Screw, Cap, 3/8-16 x 1 1/2
20.	07-4032	2	Washer, Flat, 1/4
21.	07-4038	2	Washer, Lock, Split, 1/4
22.	07-4039	2	Nut, Hex, 1/4-20
23.	11-1631	1	Shield, Drive, 1-Way
24.	11-3001	1	Frame, Drive, 1-Way
25.	11-3257	1	Shield, Drive, 1-Way
26.	11-6526	1	Key, 1/4 x 1
27.	50-0115	1	Label, Danger, Rotating Driveline
28.	50-0184	1	Label, Small, White, Logo
29.	50-0249	1	Label, Plate, Part Number, Date

DRIVE ASSEMBLIES 1-WAY

Assemblies 11-17186 & 11-17187

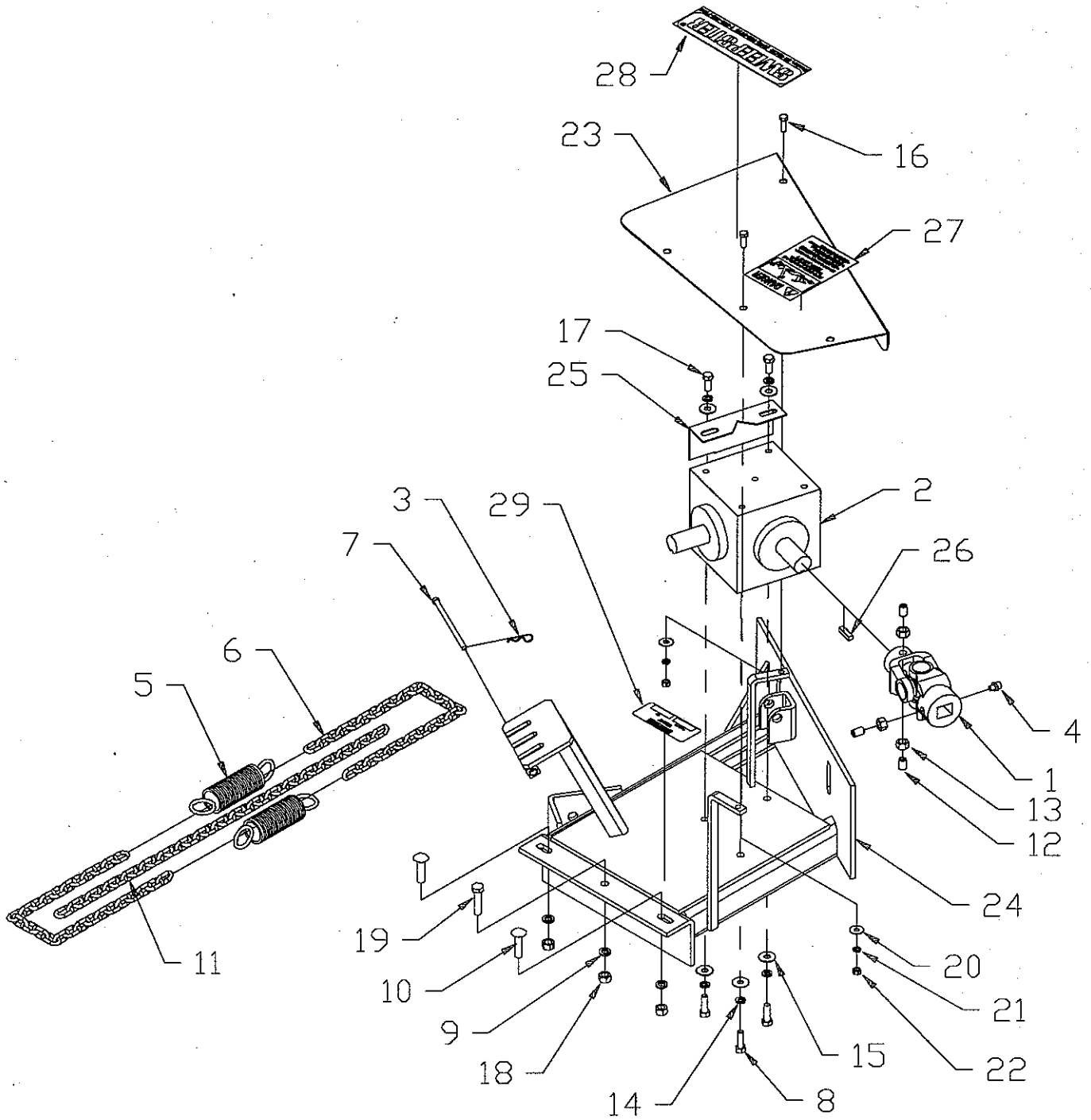

DRIVE ASSEMBLIES 2-WAY

Item	Part	Qty	Description
1.	05-0655	1	U-Joint, H7, Hex, Rectangular
2.	05-0668	1	Gearbox, 4:1, Right-Hand (11-17100)
	05-0669	1	Gearbox, 4:1, Left-Hand (11-17101)
3.	05-1075	1	U-Joint, H7, Rectangular, 3/4 Round
4.	07-0066	1	Screw, Cap, 5/8-11 x 2
5.	07-0108	1	Bolt, Carriage, 3/8 x 3/4
6.	07-0196	1	Pin, Clevis, 1/2 x 2
7.	07-0201	1	Pin, Clevis, 5/8 x 2
8.	07-0210	3	Clip, Hairpin, 14ga x 1 3/4
9.	07-0214	4	Clamp, Cable, 3/16
10.	07-0223	1	Fitting, Zerk, Straight, 1/8NPT
11.	07-0237	2	Spring, Tension, 1 13/32 x 6
12.	07-0387	2	Chain, 3/16, 26 Links
13.	07-0557	2	Bushing, 17/32 x 13/32, Plastic
14.	07-0677	2	Key, 3/16 x 1 1/4
15.	07-1294	1	Nut, Hex, 5/8-11
16.	07-1660	1	Actuator, 450 lb
17.	07-1714	6	Screw, Cap, 5/16-18 x 1
18.	07-1718	3	Washer, Lock, Split, 3/8
19.	07-1730	2	Bolt, Carriage, 3/8-16 x 1 1/2
20.	07-1872	1	Washer, Lock, Split, 5/8
21.	07-1882	3	Screw, Set, 3/8-16 x 5/8, Cup Point
22.	07-3272	3	Nut, Hex, Jam, 3/8-16
23.	07-3273	9	Washer, Lock, Split, 5/16
24.	07-3279	3	Washer, Flat, 3/8
25.	07-3275	9	Washer, Flat, 5/16
26.	07-3436	3	Screw, Cap, 5/16-18 x 3/4
27.	07-3654	3	Nut, Hex, 3/8-16
28.	07-3655	1	Screw, Cap, 3/8-16 x 1 1/2
29.	07-4036	3	Nut, Hex, Nylock, 3/8-16
30.	11-1595	1	Shaft, Rectangular, 18
31.	11-1810	1	Wire Harness
32.	11-2460	1	Shield, U-Joint
33.	11-2461	1	Frame, Swing
34.	11-3804	1	Stop, Gearbox
35.	11-7289	1	Cable, 3/16 x 32
36.	11-7479	1	Bushing, 1 x 5/8 x 7/16
37.	11-7751	1	Shield, Drive, 2-Way
38.	13-0090	1	Shield, Stacked Gearbox
	13-0091	1	Shield, 2-Way
39.	13-0848	1	Plate, Swing, 2-Way, 3/8, for Stacked Gearbox
40.	13-4420	1	Hinge, 3 1/2 x 3, 1/4 Diameter Pin
41.	50-0115	2	Label, Danger, Rotating Driveline
42.	50-0236	1	Label, Gearbox
43.	50-0249	1	Label, Plate, Part Number, Date

DRIVE ASSEMBLIES 2-WAY

Assemblies 11-17100 & 11-17101

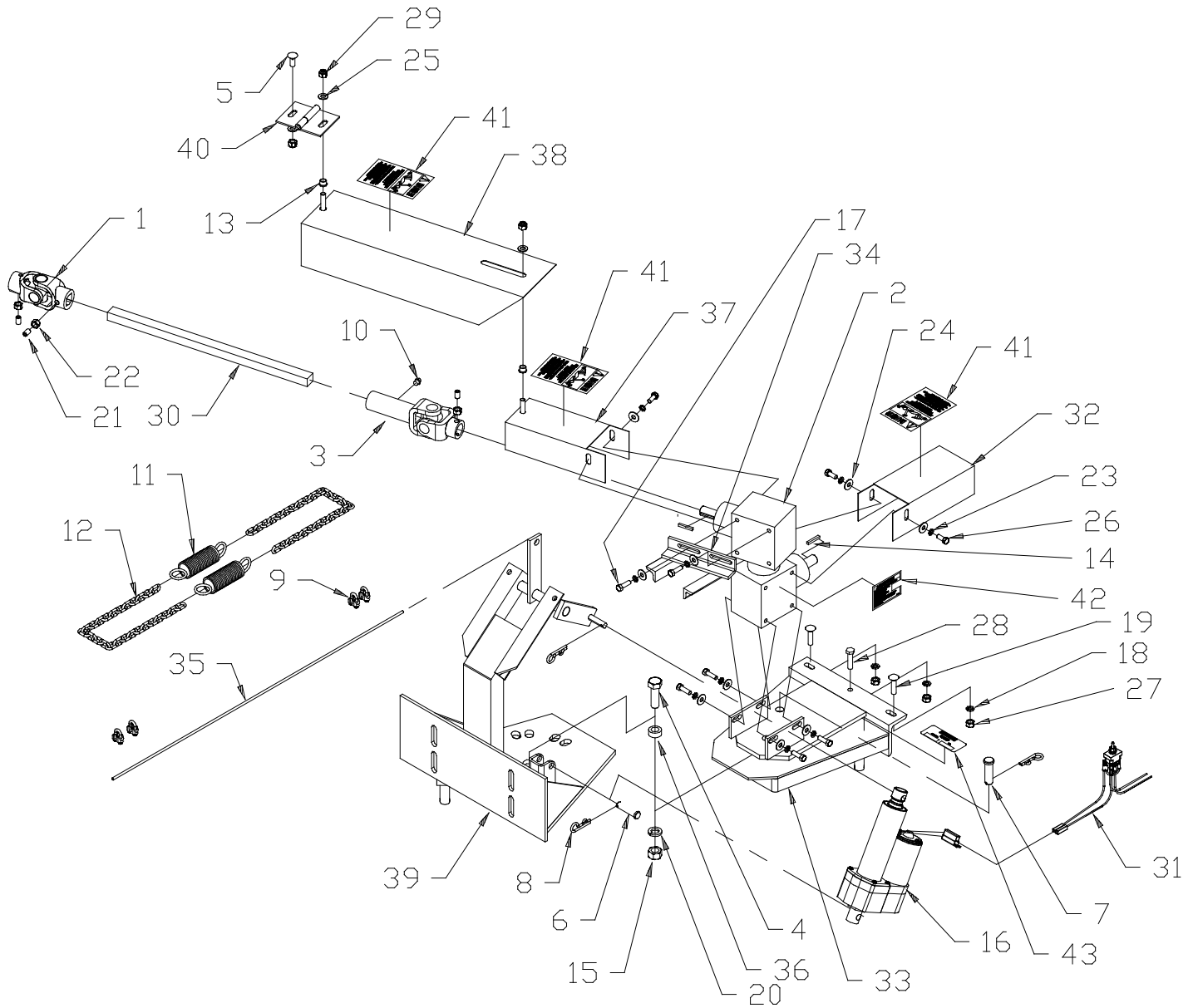

DRIVE ASSEMBLIES 2-WAY

Assemblies 11-17102 & 11-17103

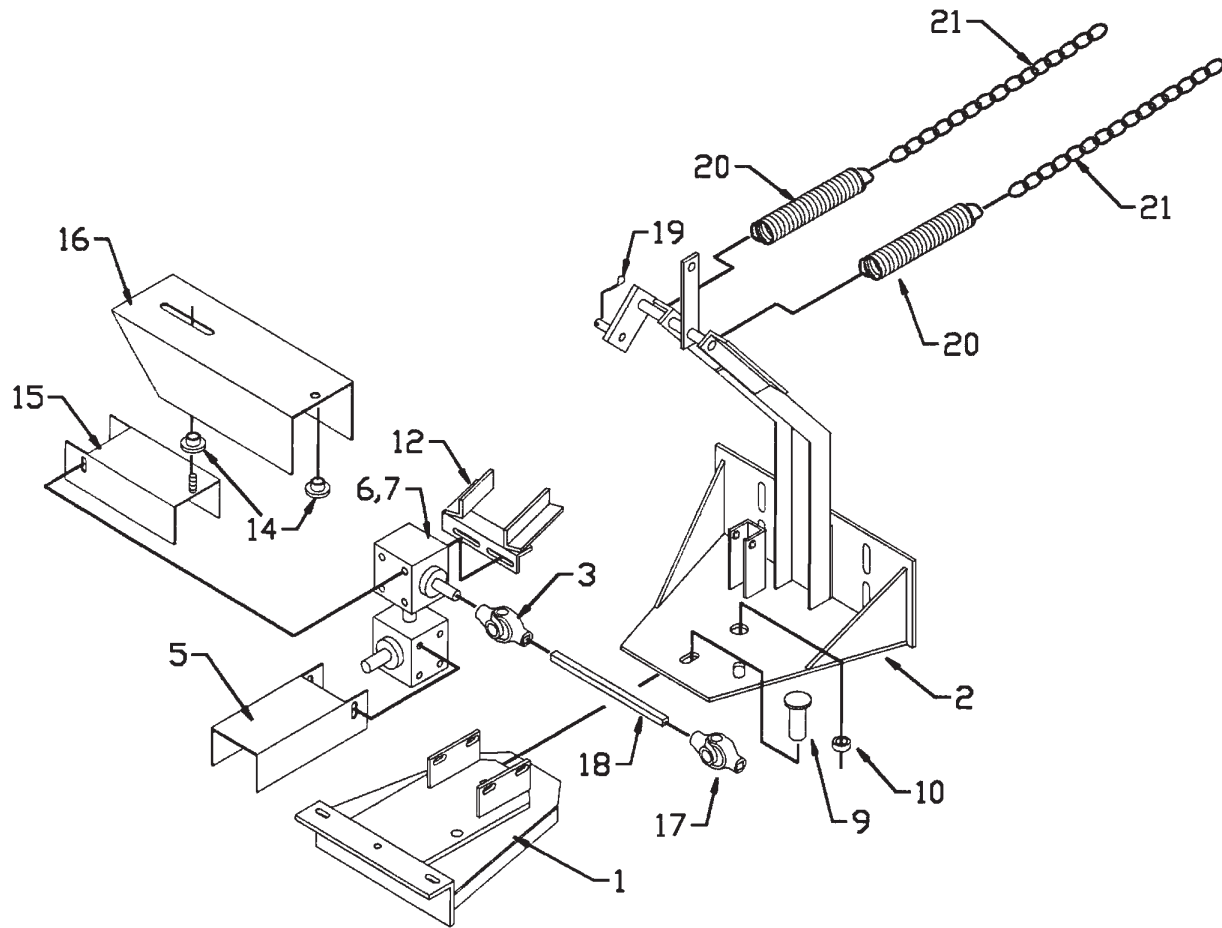

Item	Part	Qty	Description
1.	11-2461	1	Frame, Swing
2.	13-0848	1	Plate, Swing, 2-Way, 3/8
3.	05-0733	1	U-Joint, H3, Rectangular, Round, 3/4, Long Slip
5.	11-2460	1	Shield, U-Joint, 2-Way
6.	05-0668	1	Gearbox, Double, 4:1, Right-Hand (11-17102)
7.	05-0669	1	Gearbox, Double, 4:1, Left-Hand (11-17103)
9.	07-0201	1	Pin, Clevis, 5/8 x 2
10.	11-7479	1	Bushing, 1 x 5/8 x 7/16
12.	11-3804	1	Stop, Gearbox
14.	07-0557	2	Bushing, 17 x 13, Plastic
15.	11-17751	1	Shield, Drive, 2-Way
16.	13-0090	1	Shield, Stacked Box
	13-0091	1	Shield, 2-Way
17.	05-0655	1	U-Joint, H7, Hex, Rectangular
18.	11-1595	1	Shaft, Rectangular, 18
19.	07-0210	1	Clip, Hairpin, 14ga x 1 3/4
20.	07-0237	2	Spring, Tension, 1 13/32 x 6
21.	07-0387	2	Chain, 3/16, 26 Links

DRIVE ASSEMBLIES 2-WAY

Assemblies 11-17333 & 11-17334

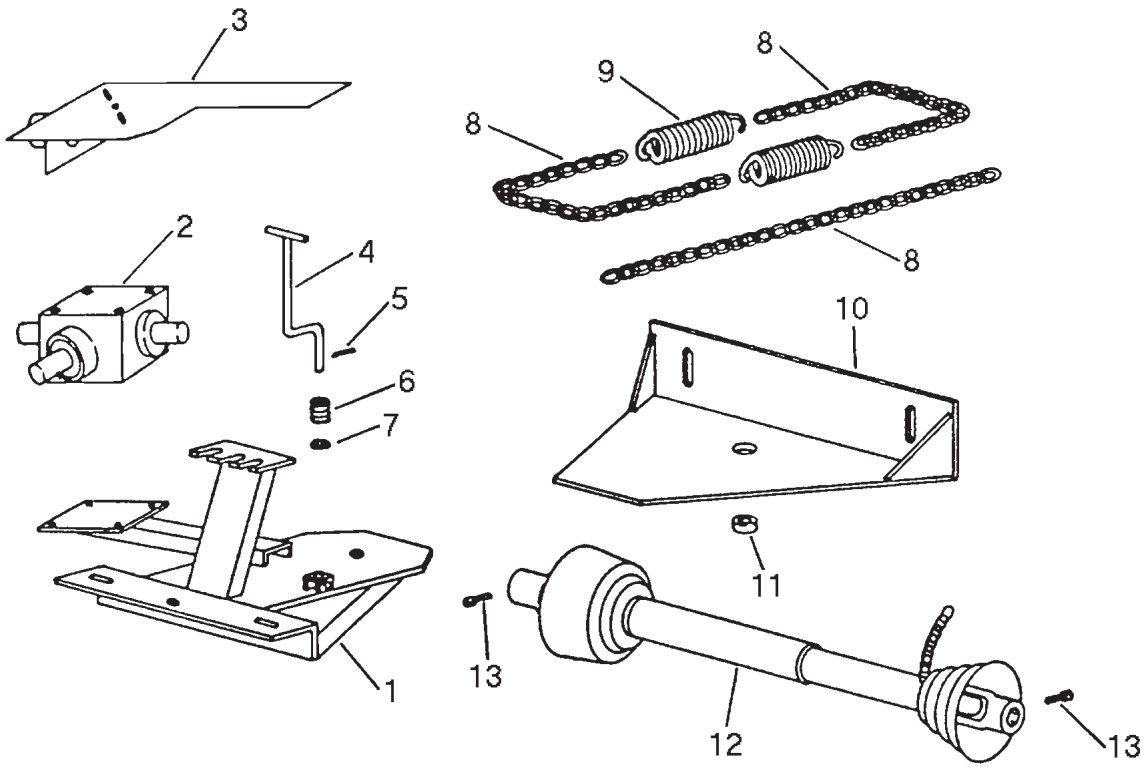

Item	Part	Qty	Description
1.	13-2200	1	Frame, Swing
2.	05-1112	1	Gearbox, 3:1, Left-Hand
3.	11-6493	1	Shield, Gearbox
4.	13-2204	1	Handle, Stop
5.	07-0203	1	Pin, Spring, Lock, 3/16 x 2 1/4
6.	07-0319A	1	Spring, Hitch, Quick
7.	07-1374	1	Washer, .625 x 1
8.	07-0387	2	Chain, 3/16, 26 Links
9.	07-0237	2	Spring, Tension, 1 13/32 x 6
10.	11-9968	1	Plate, Swing, 3:1, CV
11.	11-7479	1	Bushing, 1 x 5/8 x 7/16
12.	05-0983-1	1	Shaft, Telescoping, CV, Round, 7/8 Hex Output

DRIVE ASSEMBLIES 2-WAY

Item	Part	Qty	Description
1.	05-0983-1	1	Shaft, CV, 1 Round, 7/8 Hex, Output, 38 1/4 Extended
2.	05-1112	1	Gearbox, 3:1, Left-Hand
3.	07-3436	4	Screw, Cap, 5/16-18 x 3/4
4.	07-1714	4	Screw, Cap, 5/16-18 x 1
5.	07-2116	1	Screw, Cap, 3/8-16 x 1 1/4
6.	07-0066	1	Screw, Cap, 5/8-11 x 2
7.	07-3275	8	Washer, Flat, 5/16
8.	07-3273	8	Washer, Lock, Split, 5/16
9.	07-1872	1	Washer, Lock, Split, 5/8
10.	07-1294	1	Nut, Hex, 5/8-11
11.	07-3272	4	Nut, Hex, Jam, 3/8-16
12.	07-0209	1	Clip, Hairpin, 16ga x 1 3/8
13.	07-0237	2	Spring, Tension, 1 13/32 x 6
14.	07-0387	2	Chain, 3/16, 26 Links
15.	07-1279	4	Screw, Set, 3/8-16 x 3/4
16.	07-1709	1	Pin, Clevis, 1/4 x 4 1/2
17.	07-1718	3	Washer, Lock, Split, 3/8
18.	07-3654	3	Nut, Hex, 3/8-16
19.	07-1730	2	Bolt, Carriage, 3/8-16 x 1 1/2
20.	07-1759	1	Chain, 3/16, 36 Links
21.	11-4371	1	Kit, Manual Angle, 24
22.	11-6493	1	Shield, Gearbox
23.	11-6526	2	Key, 1/4 x 1
24.	11-7479	1	Bushing, 1 x 5/8 x 7/16
25.	13-4206	1	Plate, Swing, Top Pin
26.	13-4465	1	Frame, Swing, 3:1, CV
27.	50-0115	1	Label, Danger, Rotating Driveline
28.	50-0147	1	Label, Frequency of Lubrication, CV Shafts
29.	50-0236	1	Label, Gearbox
30.	50-0249	1	Label, Plate, Part Number, Date
31.	50-0591	1	Label, Caution, No Step
36.	07-3279	3	Washer, Flat, 3/8

DRIVE ASSEMBLIES 2-WAY

Assemblies 11-17177 & 11-17182

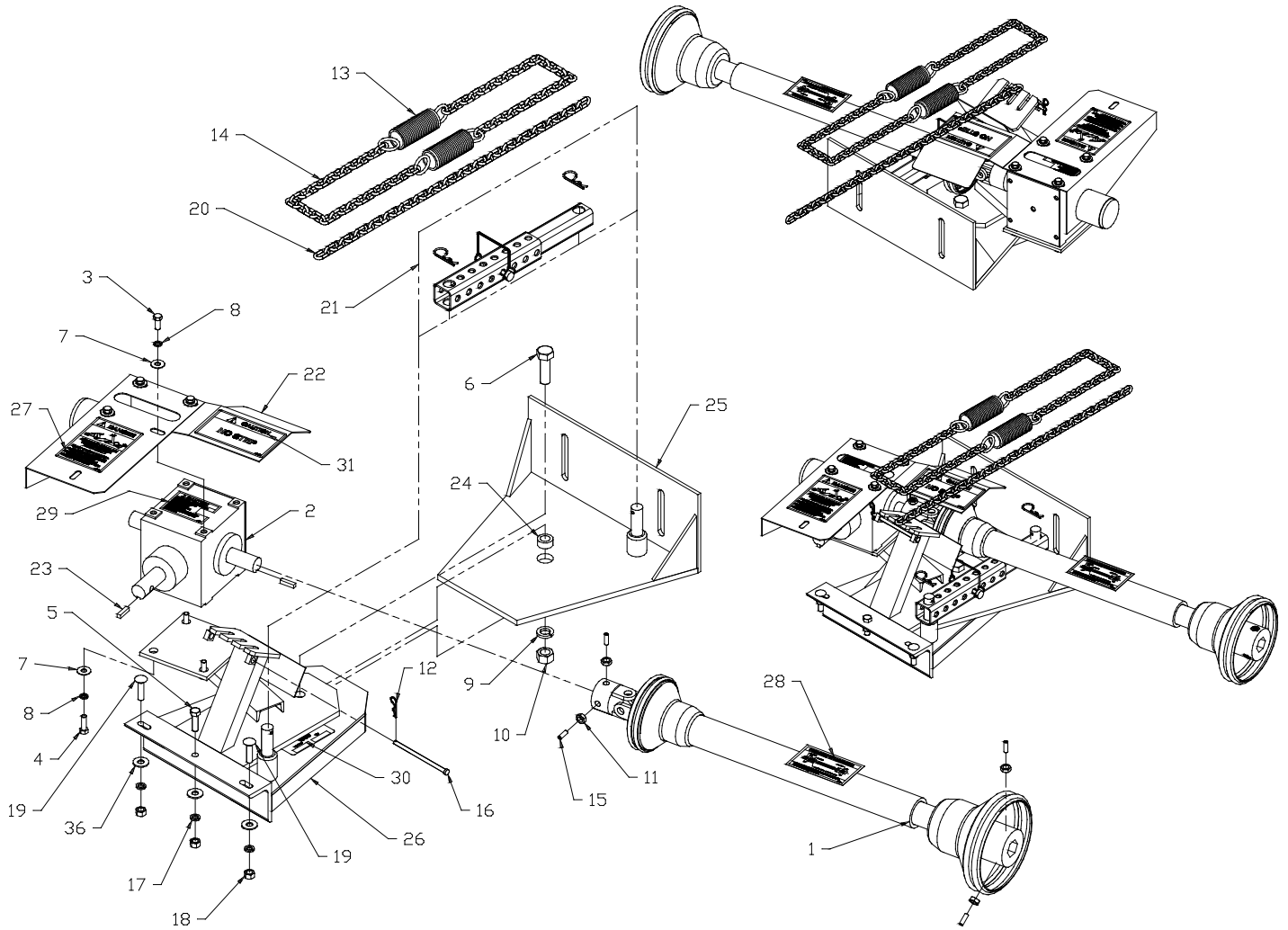

DRIVE ASSEMBLIES 2-WAY

Item	Part	Qty	Description
1.	05-0983-1	1	Shaft, CV, 1 Round, 7/8 Hex, Output, 38 1/4 Extended
2.	05-1113	1	Gearbox, 1:1, Left-Hand (11-17371)
	05-1114	1	Gearbox, 1:1, Right-Hand (11-17372)
3.	07-0018	4	Screw, Cap, 3/8-16 x 1
4.	07-0066	1	Screw, Cap, 5/8-11 x 2
5.	07-0203	1	Pin, Spring, Lock, 3/16 x 2 1/4
6.	07-0209	1	Clip, Hairpin, 16ga x 1 3/8
7.	07-0237	2	Spring, Tension, 1 13/32 x 6
8.	07-0319A	1	Spring, Hitch, Quick
9.	07-0387	2	Chain, 3/16, 26 Links
10.	07-1294	1	Nut, Hex, 5/8-11
11.	07-1374	1	Washer, .625 x 1
12.	07-1709	1	Pin, Clevis, 1/4 x 4 1/2
13.	07-1718	6	Washer, Lock, Split, 3/8
14.	07-1730	2	Bolt, Carriage, 3/8-16 x 1 1/2
15.	07-1759	1	Chain, 3/16, 36 Links
16.	07-1872	1	Washer, Lock, Split, 5/8
17.	07-3279	6	Washer, Flat, 3/8
18.	07-3654	3	Nut, Hex, 3/8-16
19.	07-0041	1	Screw, Cap, 3/8-16 x 1 1/2
20.	07-0023	2	Screw, Cap, 3/8 x 3/4
21.	11-6526	2	Key, 1/4 x 1
22.	11-7479	1	Bushing, 1 x 5/8 x 7/16
23.	11-7622	1	Handle, Stop
24.	11-9968	1	Plate, Swing
25.	13-3310	1	Frame, Mounting, 1:1
26.	13-3389	1	Shield, Frame
27.	50-0115	1	Label, Danger, Rotating Driveline
28.	50-0184	1	Label, Small, White, Logo
29.	50-0249	1	Label, Plate, Part Number, Date

Not Shown:

50-0236	1	Label, Gearbox
---------	---	----------------

DRIVE ASSEMBLIES 2-WAY

Assemblies 11-17371 & 11-17372

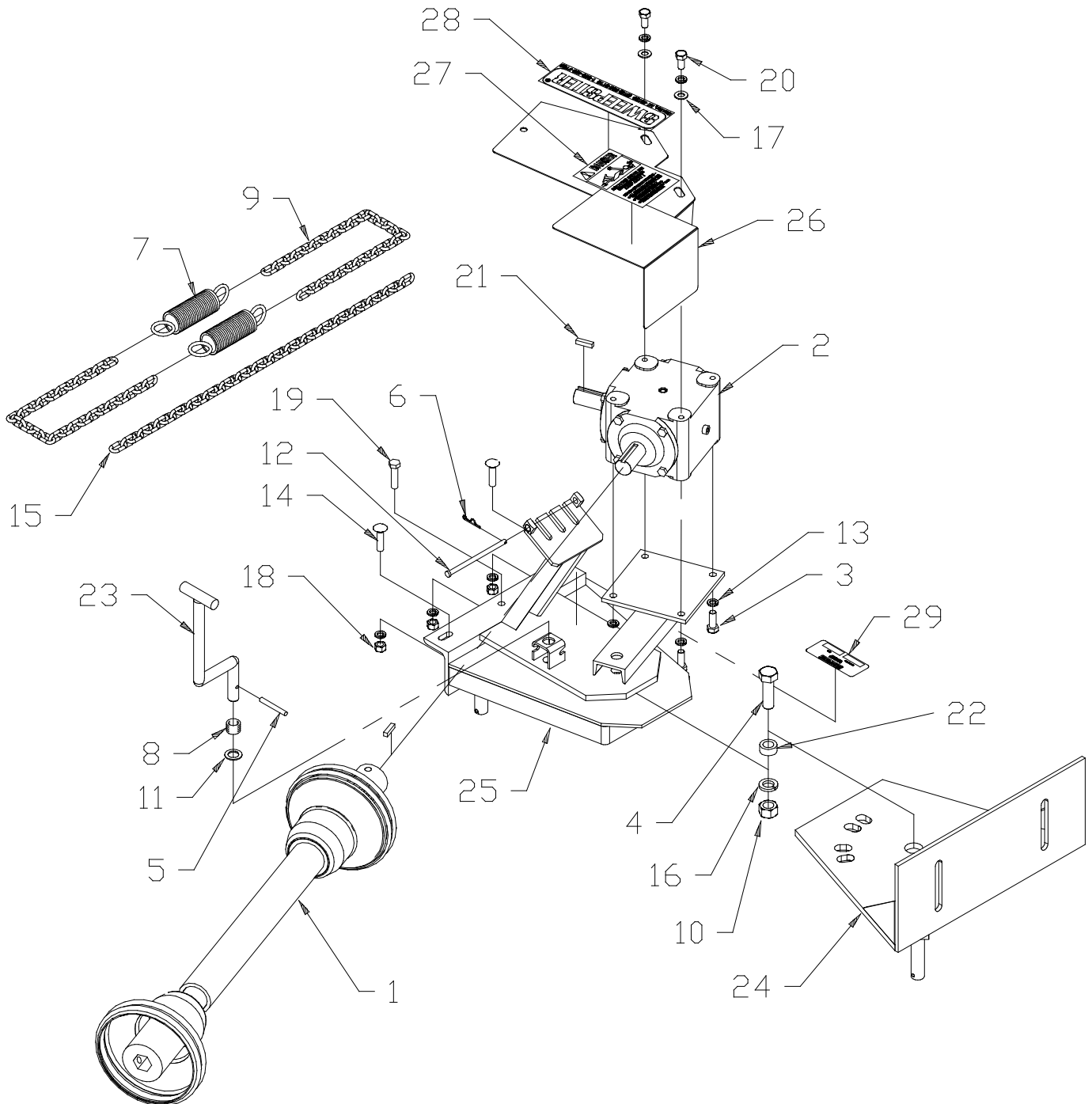

DRIVE ASSEMBLIES 2-WAY

Item	Part	Qty	Description
1.	05-1114	1	Gearbox, 1:1, Right-Hand
2.	05-0983	1	Shaft, Telescoping, CV, 1 Round 7/8 Hex, Output, 42 1/4 Extended
3.	07-4052	2	Screw, Cap, 3/8 x 3/4
4.	07-0018	4	Screw, Cap, 3/8-16 x 1
5.	07-2116	1	Screw, Cap, 3/8-16 x 1 1/4
6.	07-0066	1	Screw, Cap, 5/8-11 x 2
7.	07-3279	6	Washer, Flat, 3/8
8.	07-1718	3	Washer, Lock, Split, 3/8
9.	07-1872	1	Washer, Lock, Split, 5/8
10.	07-1294	1	Nut, Hex, 5/8-11
11.	07-0209	1	Clip, Hairpin, 16ga x 1 3/8
12.	07-0237	2	Spring, Tension, 1 13/32 x 6
13.	07-0387	2	Chain, 3/16, 26 Links
14.	07-1709	1	Pin, Clevis, 1/4 x 4 1/2
16.	07-3654	3	Nut, Hex, 3/8-16
17.	07-1717	2	Bolt, Carriage, 3/8-16 x 1 1/4
18.	07-1759	1	Chain, 3/16, 36 Links
19.	11-5819	1	Kit, Manual, Angle, 24
20.	11-6526	2	Key, 1/4 x 1
21.	11-7479	1	Bushing, 1 x 5/8 x 7/16
22.	11-7949	1	Shield, CV
23.	13-1448	1	Frame, Swing
24.	13-4206	1	Plate, Swing, Top Pin
25.	50-0115	1	Label, Danger, Rotating Driveline
26.	50-0184	1	Label, Small, White, Logo
27.	50-0236	1	Label, Gearbox
28.	50-0249	1	Label, Plate, Part Number, Date

DRIVE ASSEMBLIES 2-WAY

Assemblies 11-17198 & 11-17231

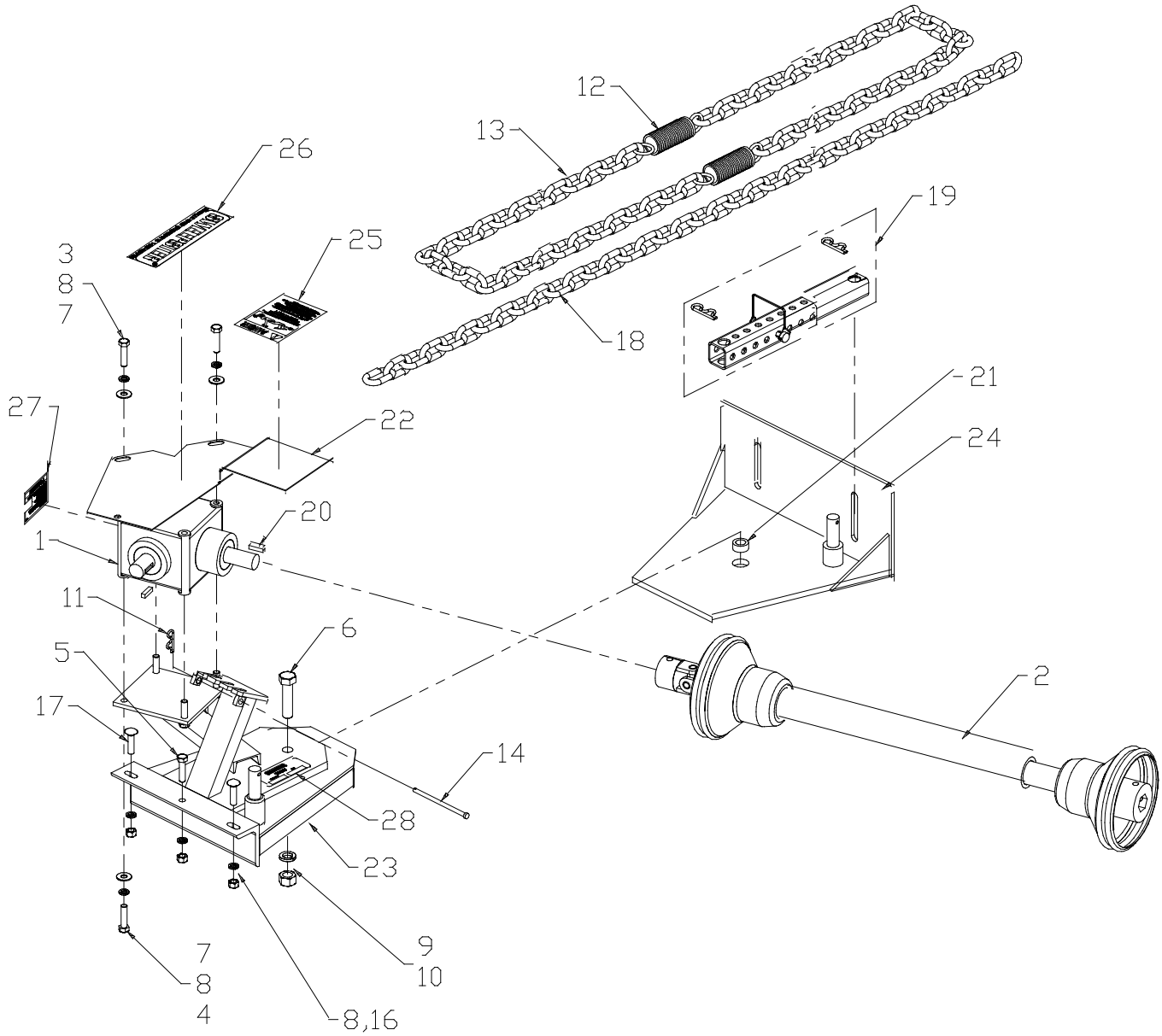

GEARBOXES

Gearbox 05-0003
1:1 Ratio, Right Hand

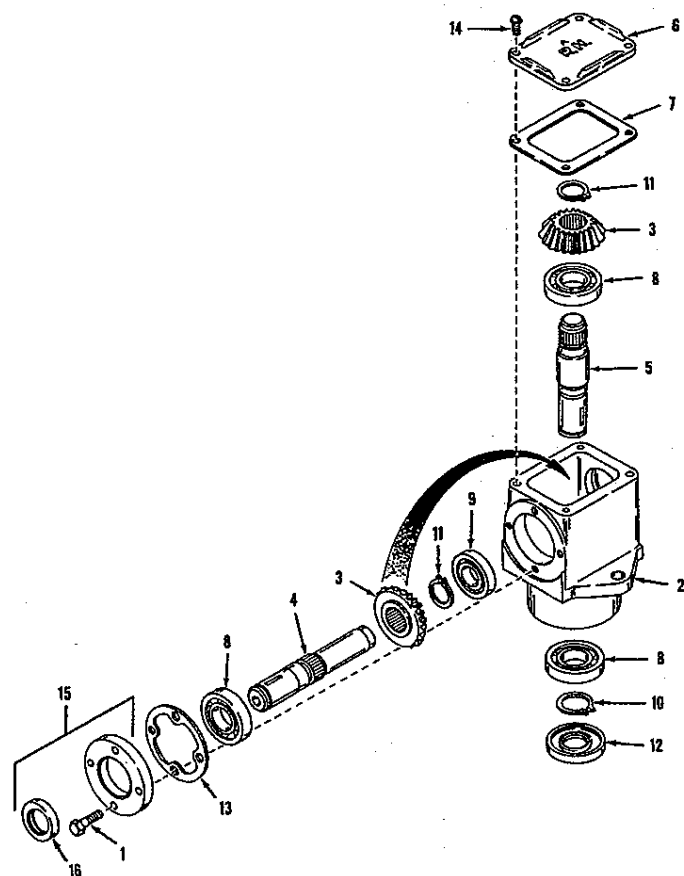

Item	Parts	Qty	Description
1.	05-0573	1	Screw
2.	05-0559	1	Housing
3.	05-0560	2	Gear
4.	05-0561	1	Shaft, Output, Right Hand
5.	05-0562	1	Shaft, Input, Right Hand
6.	50-0563	1	Cover
7.	05-0564	1	Gasket
8.	05-0565	3	Bearing
9.	05-0566	1	Bearing
10.	05-0567	1	Snap, Ring
11.	05-0568	1	Snap ring
12.	05-0569	1	Seal
13.	05-0570	1	Gasket
14.	05-0571	4	Screw
15.	05-0571A	1	Cap
16.	05-0572	1	Seal

Gearbox 05-0004
1:1 Ratio, Left Hand

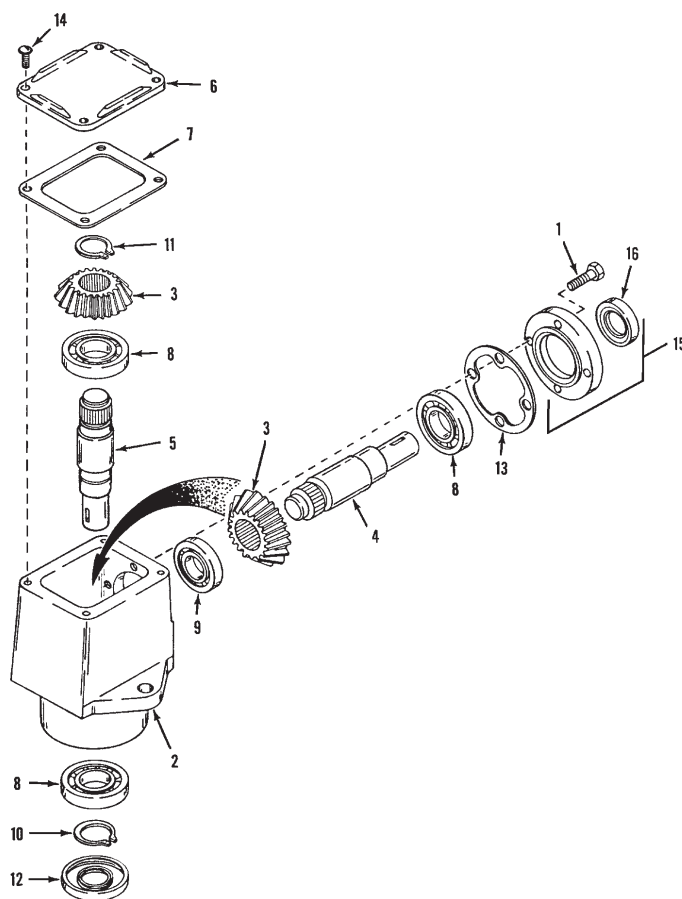

Item	Parts	Qty	Description
1.	05-0573	1	Screw
2.	05-0559	1	Housing
3.	05-0560	2	Gear
4.	05-0575	1	Shaft, Output, Left Hand
5.	05-0576	1	Shaft, Input, Left Hand
6.	50-0563	1	Cover
7.	05-0564	1	Gasket
8.	05-0565	3	Bearing
9.	05-0566	1	Bearing
10.	05-0567	1	Snap, Ring
11.	05-0568	1	Snap ring
12.	05-0569	1	Seal
13.	05-0570	1	Gasket
14.	05-0571	4	Screw
15.	05-0571A	1	Cap
16.	05-0572	1	Seal

GEARBOXES

Gearboxes 05-0668 & 05-669 (shown)
4:1 Ratio, Stacked

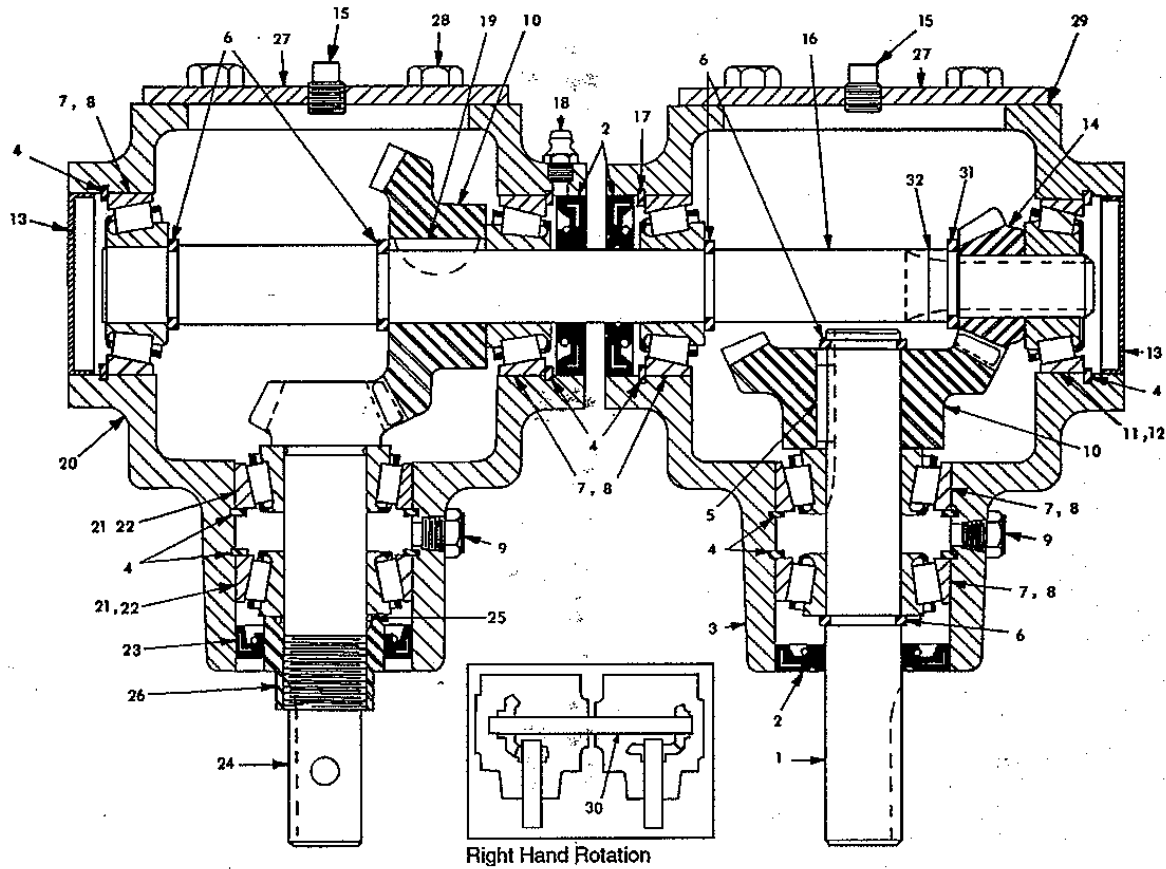

Item	Part	Qty	Description	Item	Part	Qty	Description
1.	05-0759	1	Shaft, Output	17.	05-0770	1	Shim
2.	05-0766	3	Seal	18.	05-0763	1	Fitting, Zerk
3.	05-0745	1	Housing	19.	07-0795	1	Key, Woodruff, Hard #11
4.	05-0757	8	Snap Ring	20.	05-0744	1	Housing
5.	07-0794	1	Key, 3/16 Square x 3/4	21.	05-0752	2	Bearing, Cup
6.	05-0756	5	Snap Ring, 3/4	22.	05-0753	2	Bearing, Cone
7.	05-0750	5	Bearing, Cup	23.	05-0767	1	Seal, Input
8.	05-0751	5	Bearing, Cone	24.	05-0747	1	Shaft, Pinion
9.	05-0764	2	Plug, Vent	25.	05-0769	1	O-Ring
10.	05-0749	2	Bevel, Gear	26.	05-0758	1	Stake, Nut, Input
11.	05-0754	1	Bearing, Cup	27.	05-0746	1	Cover
12.	05-0755	1	Bearing, Cone	28.	05-0015	8	Cap, Screw, 5/16-18 x 1/2
13.	05-0768	2	Cap	29.	05-0765	2	Gasket, Cover
14.	05-0748	1	Bevel, Gear, Splined	30.	05-0771	1	Shaft, Cross, (for Right Hand)
15.	03-1182-1	2	Plug, Fill-Level	31.	05-0832	1	Snap Ring
16.	05-0760	1	Shaft, Cross (for Left Hand)	32.	05-0853	1	Spacer (for 05-0760 & 05-0771)

GEARBOXES

Gearbox 05-1112
3:1 Ratio, Left Hand

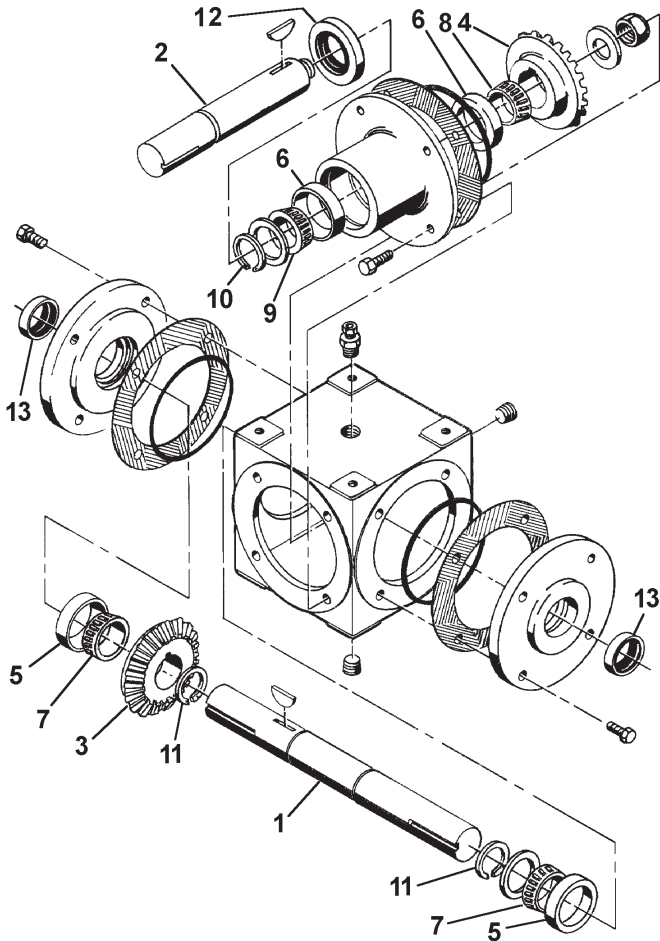

Gearboxes 05-1113 (left) & 05-1114 (Right)
1:1 Ratio

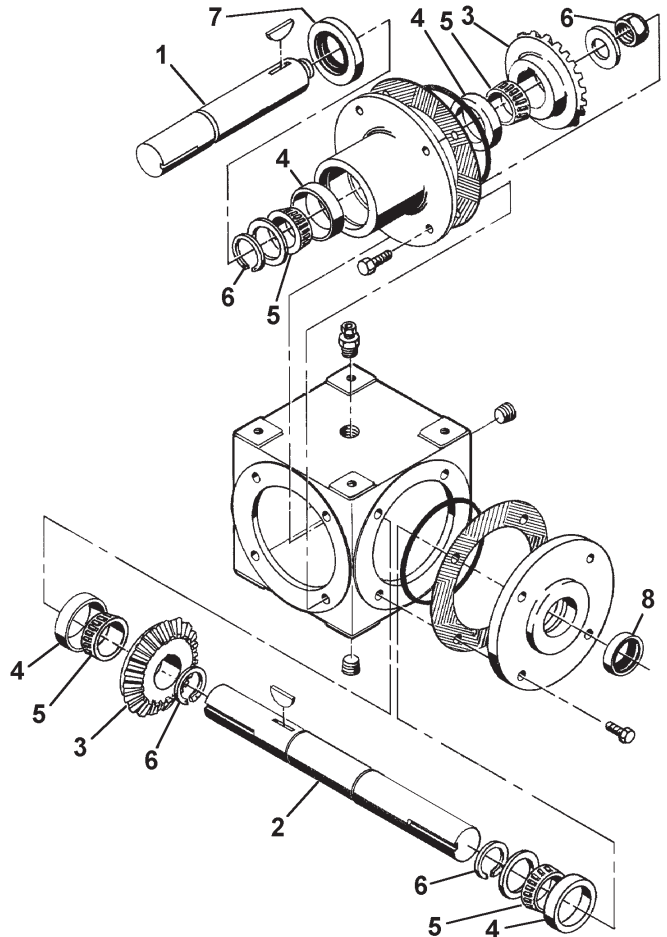

Item	Part	Qty	Description
1.	05-1158	1	Shaft, Cross
2.	05-1159	1	Shaft, Pinion
3.	05-1160	1	Gear, Standard Bevel, 42T
4.	05-1161	1	Gear, Standard Bevel, 14T
5.	05-1162	2	Cup, Bearing
6.	05-1163	2	Cup, Bearing
7.	05-1164	2	Cone, Bearing
8.	05-1165	1	Cone, Bearing
9.	05-1166	1	Cone, Bearing
10.	05-1175	2	Ring, Snap
11.	05-1176	2	Ring, Snap
12.	05-1177	1	Seal, Front
13.	05-1178	2	Seal, Rear

Item	Part	Qty	Description
1.	05-1137	1	Shaft, Pinion
2.	05-1157	1	Shaft, Cross (for 05-1113)
	05-1156	1	Shaft, Cross (for 05-1114)
3.	05-0503	2	Gear
4.	05-0506	4	Bearing, Race
5.	05-0507	4	Bearing
6.	05-1172	3	Ring, Snap
7.	05-1173	1	Seal
8.	05-1174	1	Seal

GEARBOXES

Gearbox 05-1145
3:1 Ratio, 3 Shaft

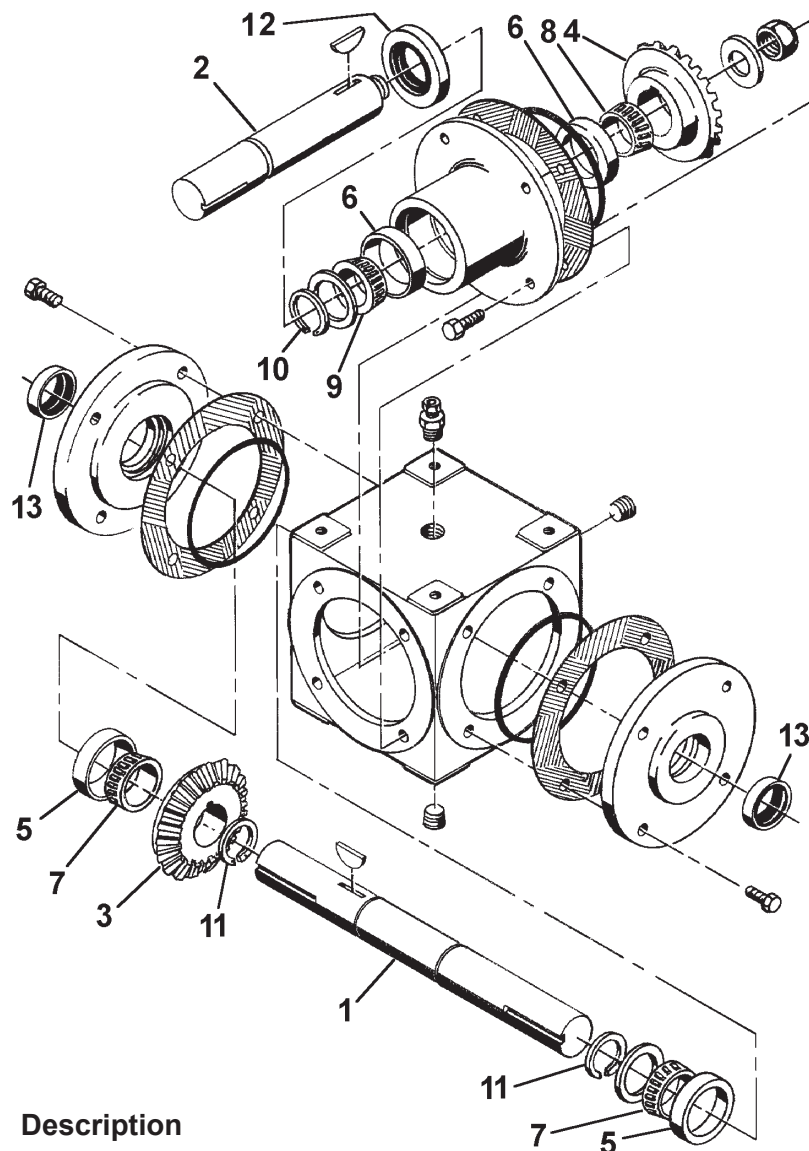

Item	Part	Qty	Description
1.	05-0776	1	Shaft, Cross
2.	05-0799	1	Shaft, Pinion
3.	05-0974	1	Gears, Set
4.	05-0974	1	Gears, Set
5.	05-1162	2	Cup, Bearing
6.	05-1163	2	Cup, Bearing
7.	05-1164	2	Cone, Bearing
8.	05-1165	1	Cone, Bearing
9.	05-1166	1	Cone, Bearing
10.	05-1175	2	Ring, Snap
11.	05-1176	2	Ring, Snap
12.	05-1177	1	Seal, Front
13.	05-1178	2	Seal, Rear

MANUAL ANGLE KIT

Assembly 11-5819

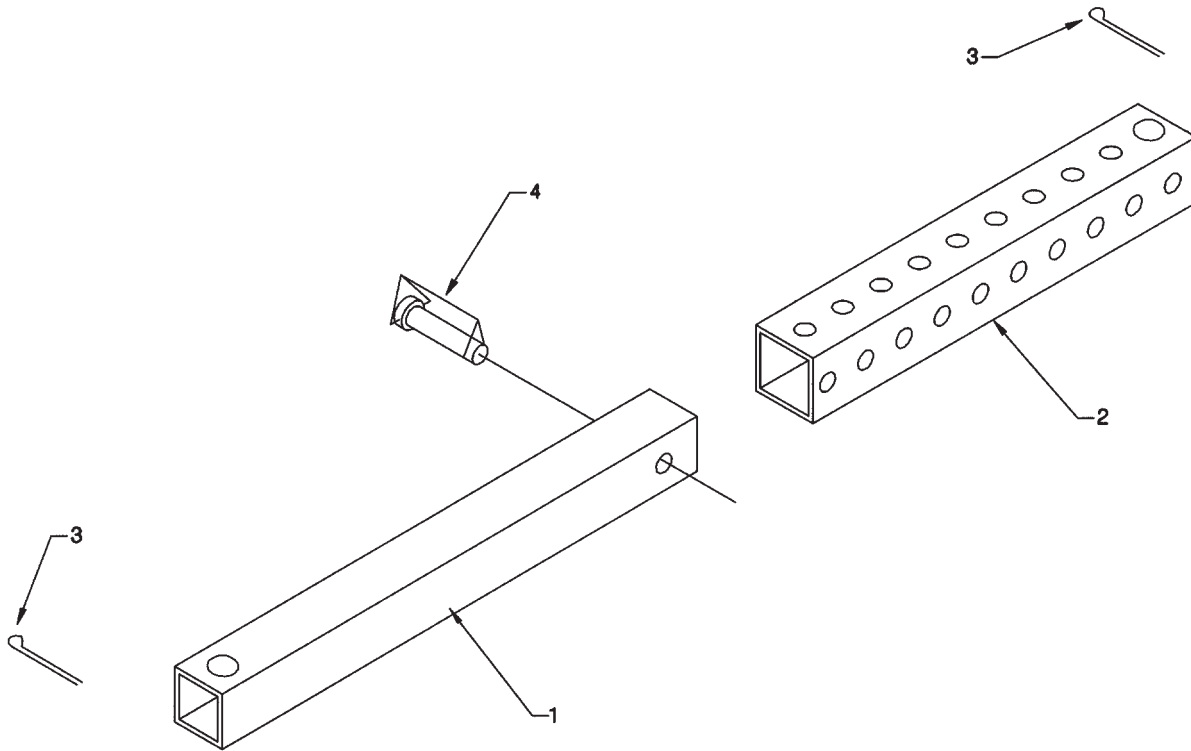

Item	Part	Qty	Description
1.	13-4194	1	Tube, Link, In
2.	13-4193	1	Tube, Link, Out
3.	07-0210	2	Clip, Hairpin, 14ga x 1 3/4
4.	07-2105	1	Pin, Lock, 3/8 Square Bail

OPTION - DIRT DEFLECTORS

Installation

1. Clamp the extension plate to the front of the hood, centered from left to right. The top edge of the extension plate must be 2 inches (51mm) from the bend in the hood.
 2. Transfer punch holes from the extension plate to the hood. Remove the extension plate and drill holes with a 13/32 inch bit.
 3. Place the rubber flap and then the retainer plate on the bottom edge of the extension plate. Insert 3, 5/16-18 x 1 inch carriage bolts in the middle 3 holes. Secure with lock washers and nuts.
 4. Attach the extension plate to the hood with 5, 3/8-16 x 1 inch cap screws, lock washers and nuts. Do not tighten the hardware.
 5. On one side of the sweeper, remove the front screw that secures the hood to the brush frame (figure 1). Secure the extension bracket to the brush frame with hardware just removed. Repeat on the other side of the sweeper.
 6. On both sides of the sweeper, attach extension brackets to the outside holes in the extension plate and flap assembly. Use 2, 5/16-18 x 1 1/4 inch carriage bolts, lock washers and nuts.
 7. Tighten all hardware.
-

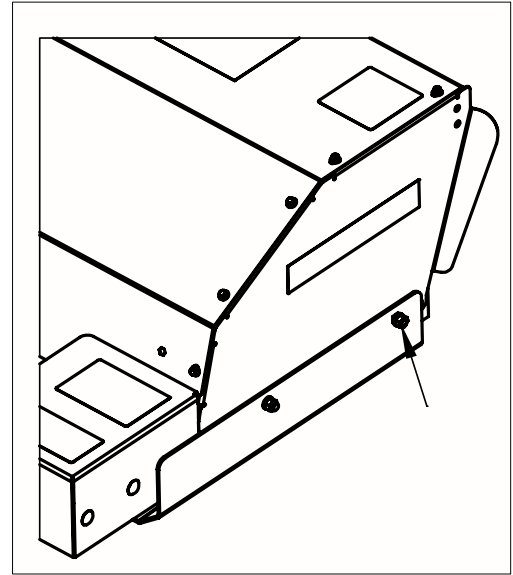
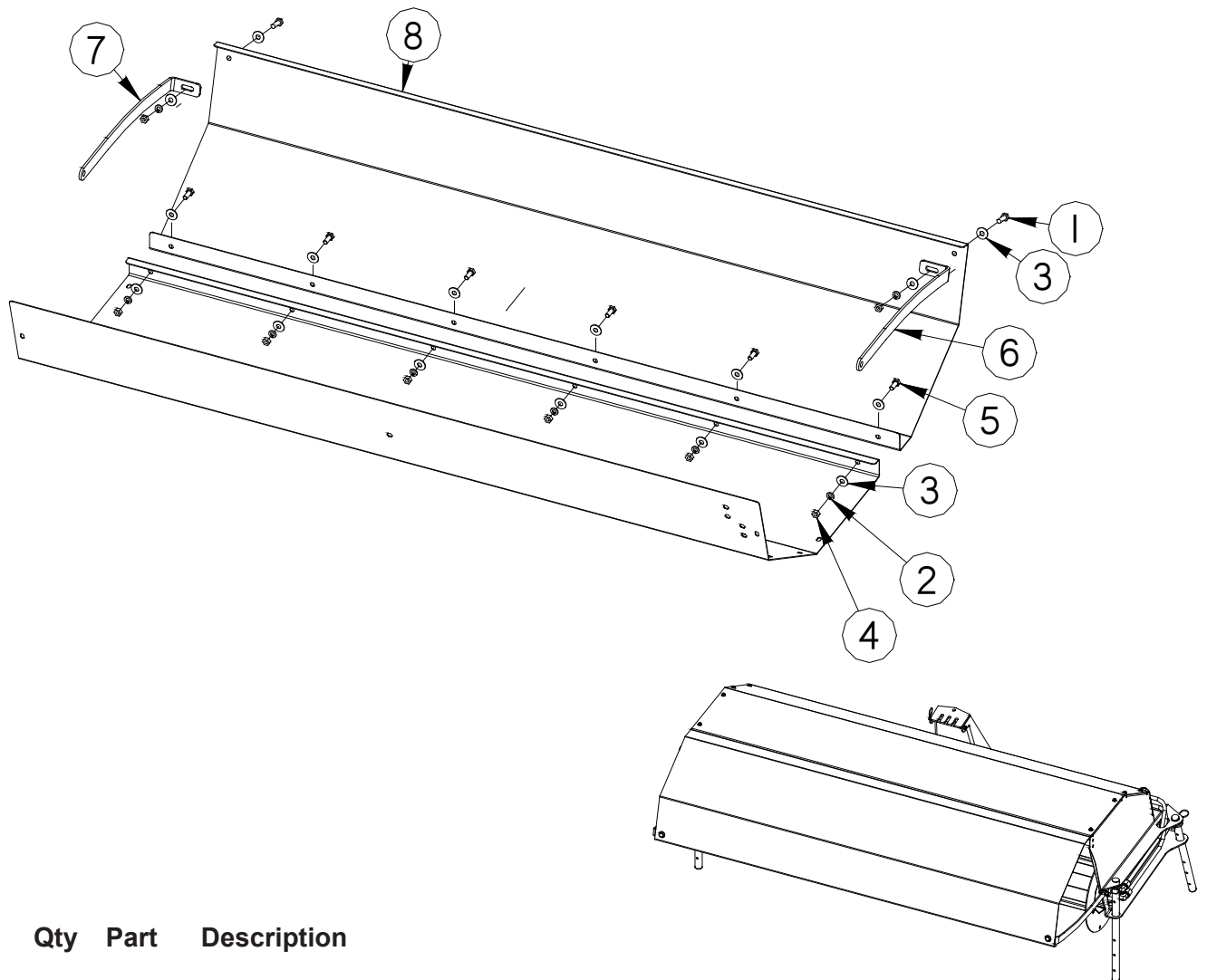

figure 1

OPTION - DIRT DEFLECTORS



Item	Qty	Part	Description
1.	07-1714	2	Screw, HHC, Gr8, 5/16-18 x 1
2.	07-3273	7	Washer, Lock, Split, Medium, 5/16, 4 ft
	07-3273	8	Washer, Lock, Split, Medium, 5/16, 5,6 ft
3.	07-3275	14	Washer, Flat, Gr8, 5/16, 4 ft
	07-3275	16	Washer, Flat, Gr8, 5/16, 5,6 ft
4.	07-3278	7	Nut, Hex, Gr8, 5/16-18, 4 ft
	07-3278	8	Nut, Hex, Gr8, 5/16-18, 5,6 ft
5.	07-3436	5	Screw, HHC, Gr8, 5/16-18 x 3/4, 4 ft
	07-3436	6	Screw, HHC, Gr8, 5/16-18 x 3/4, 5,6 ft
6.	13-13634	1	Plate, Mounting, Left
7.	13-13635	1	Plate Mounting, Right
8.	13-13645	1	Sheet, Deflector, 4 ft
	13-13644	1	Sheet, Deflector, 5 ft
	13-13633	1	Sheet, Deflector, 6 ft

OPTION - HYDRAULIC ANGLE KIT

Installation

Figure 1 shows the kit fully installed.

NOTICE: **AVOID DAMAGE TO THE SWING CYLINDER.** Remove the manual angle T-pin before installing the hydraulic angle kit.

1. Remove the T-pin from the swing assembly by driving out the roll pin and lifting the pin.

Install adapter fittings on both cylinder ports.

Install the flow restrictor fitting (figure 1) on the rear adapter fitting. A restrictor fitting is necessary for proper operation and to prevent damage to the hydraulic swing kit.

4. Hook 1 hose to the restrictor fitting and 1 to the front adapter fitting.
5. Place the swing cylinder on pins welded to the swing assembly. Install a 3/4 inch flat washer and cotter pin on each swing assembly pin to secure the swing cylinder.
6. Connect hoses to the tractor hydraulics.

NOTE: Because of the numerous types of quick coupler fittings available, the user furnishes quick coupler fittings for this kit.

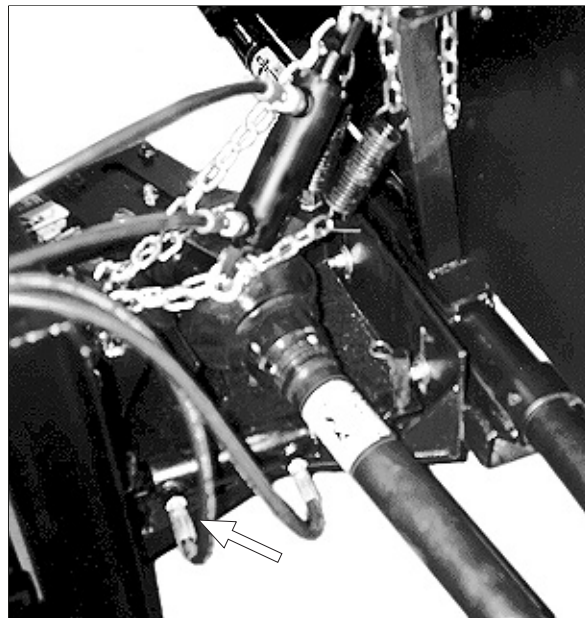
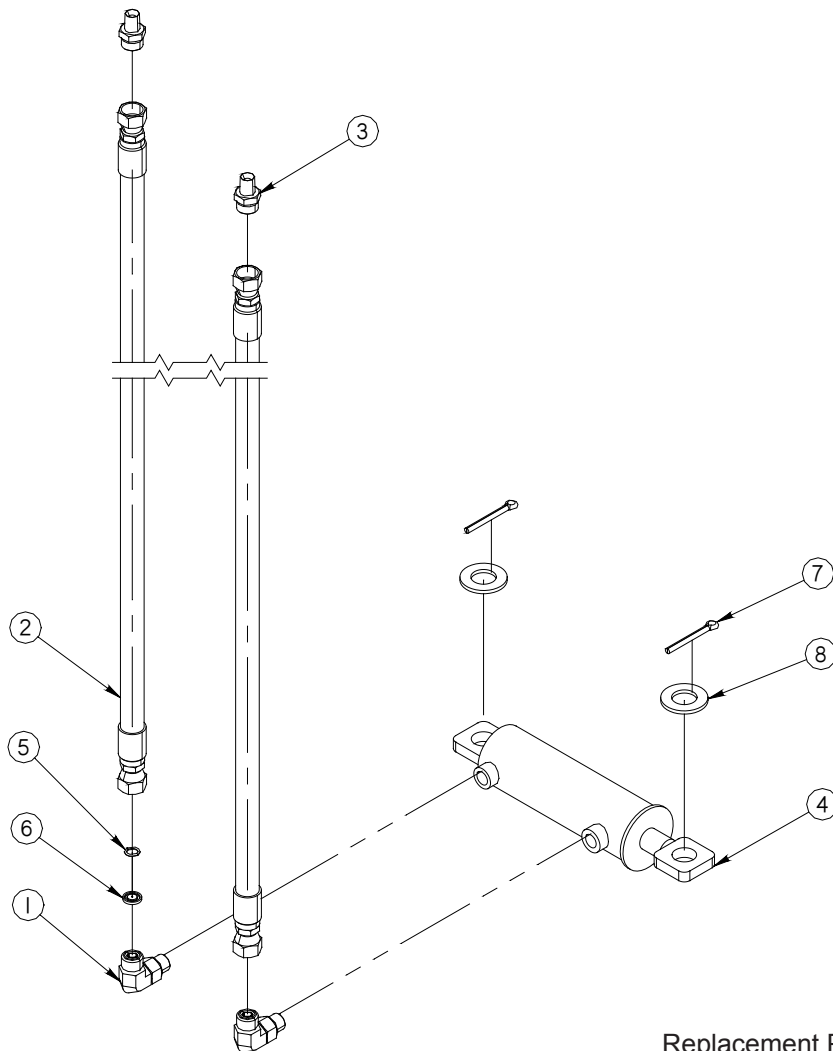

figure 1

OPTION - HYDRAULIC ANGLE KIT

To order, ask for kit 11-4191



Replacement Parts for 03-5719:

46072 Seal Kit
114406 Cylinder Rod

Item	Part	Qty	Description
1.	03-2092	2	Fitting, Elbow, HP, 90°, 9/16MOR, 3/8MFS
2.	03-2159	2	Fitting, Adapter, HP, 3/8MFS, 1/4MP
3.	03-2270	2	Hose, 3/8 x 72, 2W, 3/8FFS, 3/8FFS
4.	03-3381	1	Cylinder, Hydraulic, 1 3/4 x 4 x 9 (09/23/09 & Before)
	03-5719	1	Cylinder, 1.75 x .75 x 4, 3.5K (09/24/09 & After)
5.	03-3573	1	O-Ring, Face Seal, 3/8, SAE #6
6.	03-4668	1	Plate, Hydraulic, Orifice, .028, #6, O-Ring, Face Seal
7.	07-0206	2	Pin, Cotter, Gr2, 3/16 x 2
8.	07-17882	2	Washer, Flat, Gr2, 3/4, SAE, 1 1/2 OD

OPTION - HYDRAULIC LIFT KITS

Installation

Figure 1 shows the lift kit fully installed.

1. Remove the transport chain and/or electric lift, if installed.
2. Attach adapter fittings to both cylinder ports, and install elbow fittings on adapter fittings. Then, attach hoses to the elbow fittings and install quick coupler fittings on the hoses.
3. Place a shackle on the rod end of the cylinder; then, attach the shackle to the brush frame upright.
4. Place a shackle on the barrel end of the cylinder and attach the chain to the shackle. Then, attach the chain to the center slot in the drive mounting assembly upright.
5. Connect quick coupler fittings to the front remote hydraulic outlets on the tractor.
6. Completely collapse the cylinder to check for adjustment.
 - If the brush head assembly lifts 4 inches (101mm) off the ground, the hydraulic lift is properly adjusted.
 - If the brush head assembly does not lift 4 inches (101mm) off the ground, adjust the chain. To raise the brush head assembly more, shorten the chain length between the cylinder and the upright. To lower the brush head assembly, add to the chain length.

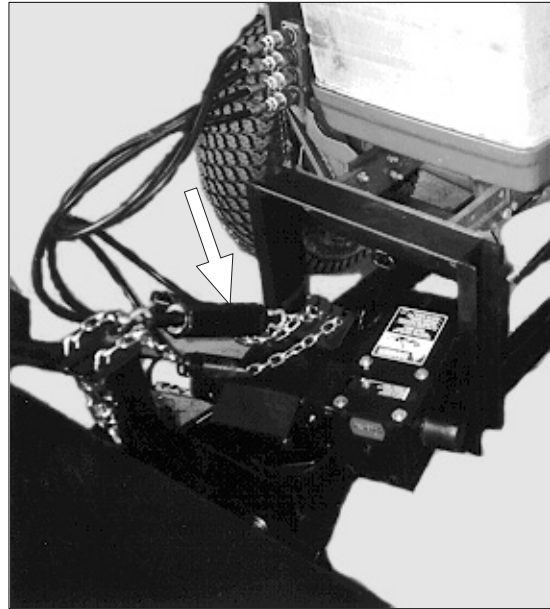
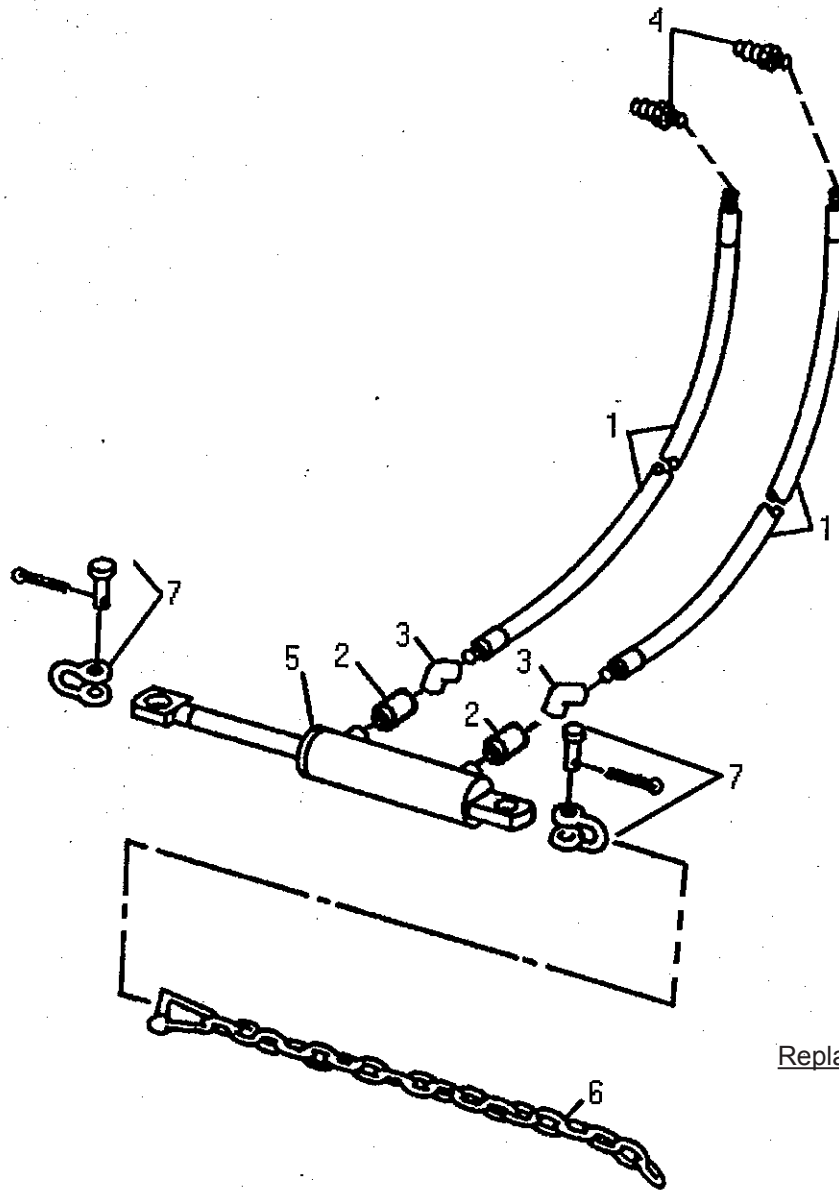

figure 1

OPTION - HYDRAULIC LIFT KITS

To order, ask for kit 11-9250



Replacement Parts for 03-5719:

46072 Seal Kit
114406 Cylinder Rod

Item	Part	Qty	Description
1.	03-0011	2	Hose, 1/4 x 36, 1W, 1/4MP
2.	03-0898	2	Fitting, Adapter, HP, 9/16MOR, 1/4FP
3.	03-1053	2	Fitting, Elbow, HP, 45°, 1/4MP, 1/4FP
4.	03-1423	2	Fitting, Quick Coupler, Male, 1/4FP
5.	03-1851	1	Cylinder, 1 3/4 x 4 x 9, 9/16 O-Ring (09/23/09 & Before)
	03-5719	1	Cylinder, 1.75 x .75 x 4, 3.5K (09/24/09 & After)
6.	07-0387	1	Chain, 3/16, 26 Links
7.	07-1732	2	Shackle, Chain, 5/16, with Screw Pin

OPTION - HYDRAULIC LIFT KITS

Installation

Figure 1 shows the lift kit fully installed.

1. Remove the electric actuator and wiring if installed on the drive assembly.
2. Place the lift plate on the pin welded to the lift linkage. Clamp the plate. Center mark the hole. Remove the plate and drill a hole in the lift linkage with a $17/32$ inch bit.
3. Attach the lift plate to the lift linkage with a $1/2$ - $13 \times 1 \ 1/4$ cap screw, flat washer, lock washer and nut. Slide a bushing onto the pin on the lift linkage and install a hairpin clip.
4. Place the rod end of the cylinder on the pin; secure with a hairpin clip.
5. Insert a bushing in the barrel end of the cylinder. Fasten the cylinder to the tab on the drive assembly using a pin and hairpin clip.
6. Install elbow fittings, hoses and quick coupler fittings on the cylinder.
7. Connect quick couplers to tractor remotes.
8. Lift and lower the sweeper to test cylinder functions.
9. Adjust the cable.
 - If the brush head assembly does not raise enough, decrease the amount of cable between the uprights.
 - If the brush head assembly raises too much, increase the amount of cable between the uprights.

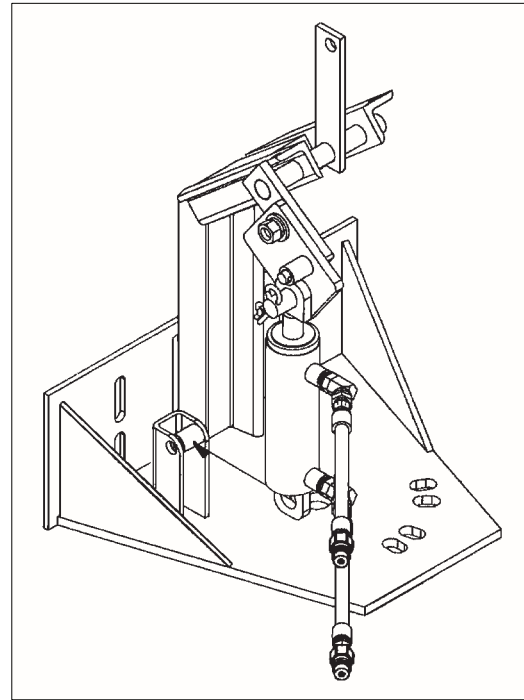
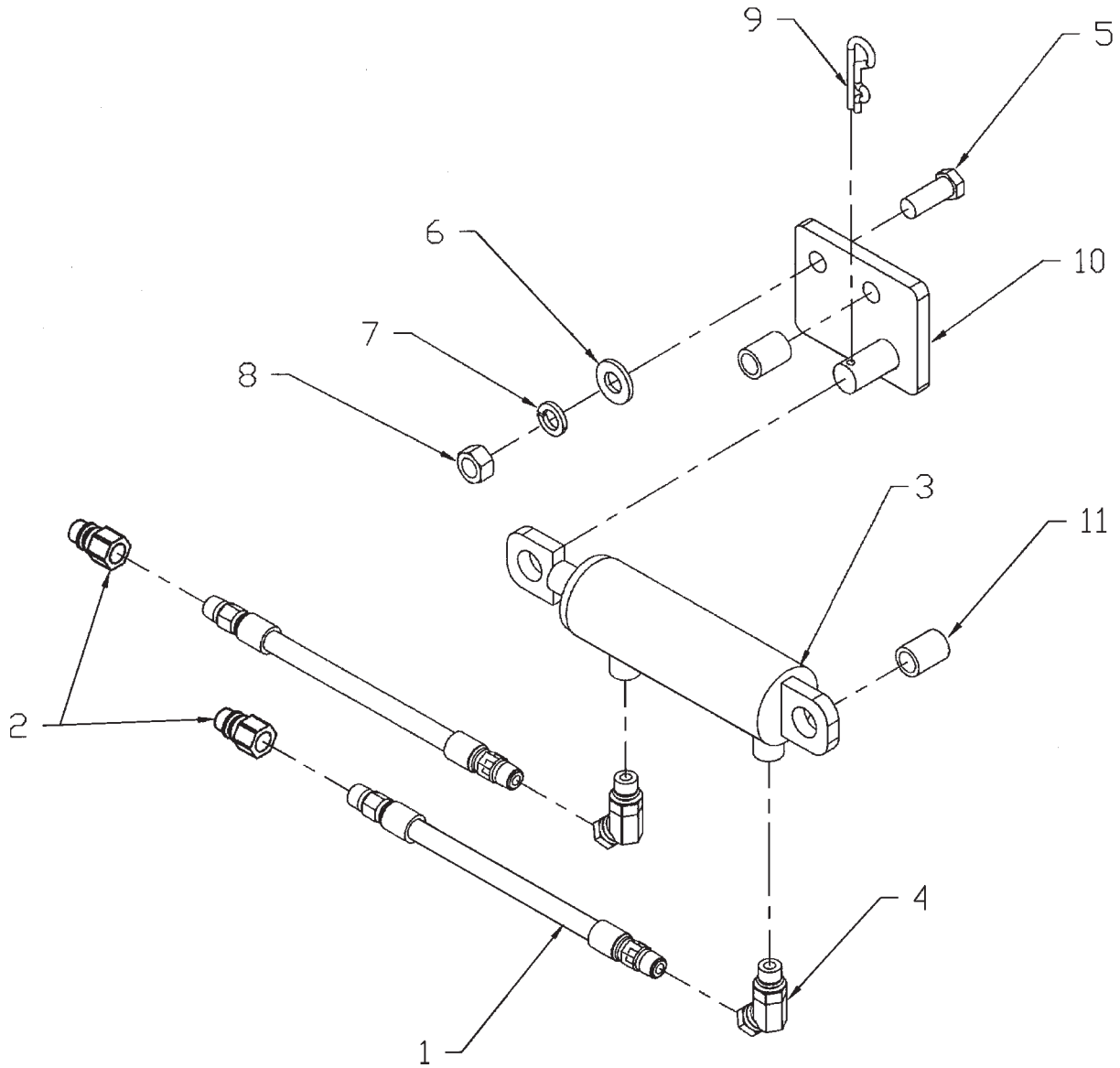

figure 1

OPTION - HYDRAULIC LIFT KITS

For 11-17100 & 11-17101
To order, ask for kit 13-3149



Replacement Parts for 03-5719:

46072 Seal Kit
114406 Cylinder Rod

Item	Part	Qty	Description
1.	03-0011	2	Hose, 1/4 x 36, 1W, 1/4MP
2.	03-1423	2	Fitting, Quick Coupler, Male, 1/4FP
3.	03-1851	1	Cylinder, 1 3/4 x 4 x 9, 9/16 O-Ring (09/23/09 & Before)
	03-5719	1	Cylinder, 1.75 x .75 x 4, 3.5K (09/24/09 & After)
4.	03-1884	2	Fitting, Elbow, HP, 45°, 9/16MOR, 1/4FPS
5.	07-0039	1	Screw, Cap, 1/2-13 x 1 1/4
6.	07-0156	1	Washer, Flat, 1/2
7.	07-0170	1	Washer, Lock, Split, 1/2
8.	07-1764	1	Nut, Hex, 1/2-13
9.	07-0210	1	Clip, Hairpin, 14ga x 1 3/4
10.	13-3132	1	Weldment, Lift, Hydraulic
11.	13-4168	1	Bushing, Spacer



BOLT TORQUE SPECIFICATIONS

GENERAL TORQUE SPECIFICATION TABLES

Use the following charts when determining bolt torque specifications when special torques are not given. Always use grade 5 or better when replacing bolts.



SAE BOLT TORQUE SPECIFICATIONS

NOTE: The following torque values are for use with extreme pressure lubricants, plating or hard washer applications. Increase torque 15% when using hardware that is unplated and either dry or lubricated with engine oil.

Bolt Size		SAE GRADE 5 TORQUE				SAE GRADE 8 TORQUE				Bolt head identification marks as per grade. NOTE: Manufacturing Marks Will Vary
		Pounds Feet		Newton-Meters		Pounds Feet		Newton-Meters		
Inches	Millimeters	UNC	UNF	UNC	UNF	UNC	UNF	UNC	UNF	
1/4	6.35	8	9	11	12	10	13	14	18	<p>GRADE 2</p>  <p>GRADE 5</p>  <p>GRADE 8</p> 
5/16	7.94	14	17	19	23	20	25	27	34	
3/8	9.53	30	36	41	49	38	46	52	62	
7/16	11.11	46	54	62	73	60	71	81	96	
1/2	12.70	68	82	92	111	94	112	127	152	
9/16	14.29	94	112	127	152	136	163	184	221	
5/8	15.88	128	153	174	207	187	224	254	304	
3/4	19.05	230	275	312	373	323	395	438	536	
7/8	22.23	340	408	461	553	510	612	691	830	
1	25.40	493	592	668	803	765	918	1037	1245	
1-1/8	25.58	680	748	922	1014	1088	1224	1475	1660	
1-1/4	31.75	952	1054	1291	1429	1547	1700	2097	2305	
1-3/8	34.93	1241	1428	1683	1936	2023	2312	2743	3135	
1-1/2	38.10	1649	1870	2236	2535	2686	3026	3642	4103	

METRIC BOLT TORQUE SPECIFICATIONS

NOTE: The following torque values are for use with metric hardware that is unplated and either dry or lubricated with engine oil. Reduce torque 15% when using hardware that has extreme pressure lubricants, plating or hard washer applications.

Bolt head identification marks as per grade.		
		

Size of Bolt	Grade No.	Pitch (mm)	Pounds Feet	Newton-Meters	Pitch (mm)	Pounds Feet	Newton-Meters
M6	5.6	1.0	3.6-5.8	4.9-7.9	-	-	-
	8.8		5.8-4	7.9-12.7		-	-
	10.9		7.2-10	9.8-13.6		-	-
M8	5.6	1.25	7.2-14	9.8-19	1.0	12-17	16.3-23
	8.8		17-22	23-29.8		19-27	25.7-36.6
	10.9		20-26	27.1-35.2		22-31	29.8-42
M10	5.6	1.5	20-25	27.1-33.9	1.25	20-29	27.1-39.3
	8.8		34-40	46.1-54.2		35-47	47.4-63.7
	10.9		38-46	51.5-62.3		40-52	54.2-70.5
M12	5.6	1.75	28-34	37.9-46.1	1.25	31-41	42-55.6
	8.8		51-59	69.1-79.9		56-68	75.9-92.1
	10.9		57-66	77.2-89.4		62-75	84-101.6
M14	5.6	2.0	49-56	66.4-75.9	1.5	52-64	70.5-86.7
	8.8		81-93	109.8-126		90-106	122-143.6
	10.9		96-109	130.1-147.7		107-124	145-168
M16	5.6	2.0	67-77	90.8-104.3	1.5	69-83	93.5-112.5
	8.8		116-130	157.2-176.2		120-138	162.6-187
	10.9		129-145	174.8-196.5		140-158	189.7-214.1
M18	5.6	2.0	88-100	119.2-136	1.5	100-117	136-158.5
	8.8		150-168	203.3-227.6		177-199	239.8-269.6
	10.9		175-194	237.1-262.9		202-231	273.7-313
M20	5.6	2.5	108-130	146.3-176.2	1.5	132-150	178.9-203.3
	8.8		186-205	252-277.8		206-242	279.1-327.9
	10.9		213-249	288.6-337.4		246-289	333.3-391.6

NOTE - Nylock nuts are utilized when greater resistance to vibrating loose is required, and greater operating temperatures are not a factor. In addition, like lock nuts, nylock nuts have a safety feature that if the bolt does vibrate loose, the nut will remain on the screw. Install nylock nuts to the standard torque shown above.

HYDRAULIC TORQUE SPECIFICATIONS

Face Seal: Assembly, Tube to Fitting

NOTICE - Face seal fittings have the most reliable sealing method and therefore, should be used whenever possible.

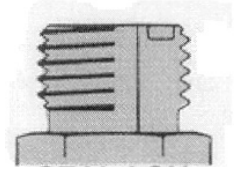

Installation

1. Make sure threads and sealing surfaces are free of burrs, nicks, scratches, or foreign materials.
2. Install proper SAE O-ring to end of fitting if not already installed. Ensure O-ring is fully seated and retained properly.
3. Lubricate O-ring with a light coating of clean hydraulic oil.
4. Position tube and nut squarely on face seal of fitting and tighten nut finger tight.
5. Using appropriate torquing device, tighten to given torque rating from the table below.

Torque Values

SAE Dash Size	Tube Side Thread Size	In-lbs	Ft-lbs
-4	9/16 - 18	220 ± 10	18 ± 1
-6	11/16 - 16	320 ± 25	27 ± 2
-8	13/16 - 16	480 ± 25	40 ± 2
-10	1 - 14	750 ± 35	63 ± 3
-12	1 3/16 - 12	1080 ± 45	90 ± 4
-16	1 7/16 - 12	1440 ± 90	120 ± 8
-20	1 11/16 - 12	1680 ± 90	140 ± 8
-24	2 - 12	1980 ± 100	165 ± 8

NOTE - ft-lb may be converted to Newton Meters by multiplying by 1.35582.

NOTE - in-lbs may be converted to Newton Meters by multiplying by 0.11298.

HYDRAULIC TORQUE SPECIFICATIONS

Straight Thread O-ring Fitting: Assembly, Fitting to Port

NOTE - Straight thread o-ring fittings are utilized to adapt hydraulic systems to motors, pumps, cylinders, and valves.

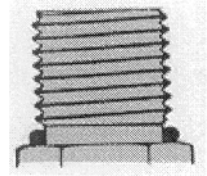

Installation (Adjustable Fitting)

1. Make sure threads and sealing surfaces are free of burrs, nicks, scratches, or any foreign materials.
2. Install proper SAE o-ring on port end of fitting if not already installed. Ensure o-ring is fully seated and retained properly.
3. Lubricate o-ring with a light coating of clean hydraulic oil.
4. Back off nut as far as possible and push washer up as far as possible. (figure 4 & 5)
5. Screw fitting into port. Hand tighten fitting until backup washer contacts face of port. (figure 6)
6. To position the fitting, unscrew to desired position, but not more than one full turn.
7. Hold fitting in position with wrench. Using appropriate torquing device, tighten nut to given torque rating from table. (figure 7)

Fitting Size	SAE Port Thread Size	In-lbs	Ft-lbs
-4	7/16 - 20	190 ± 10	16 ± 1
-6	9/16 - 18	420 ± 15	35 ± 1
-8	3/4 - 14	720 ± 25	60 ± 2
-10	7/8 - 14	1260 ± 50	105 ± 5
-12	1 1/16 - 12	1680 ± 75	140 ± 6
-16	1 5/16 - 12	2520 ± 100	210 ± 8
-20	1 5/8 - 12	3100 ± 150	260 ± 12
-24	1 7/8 - 12	3800 ± 150	315 ± 12

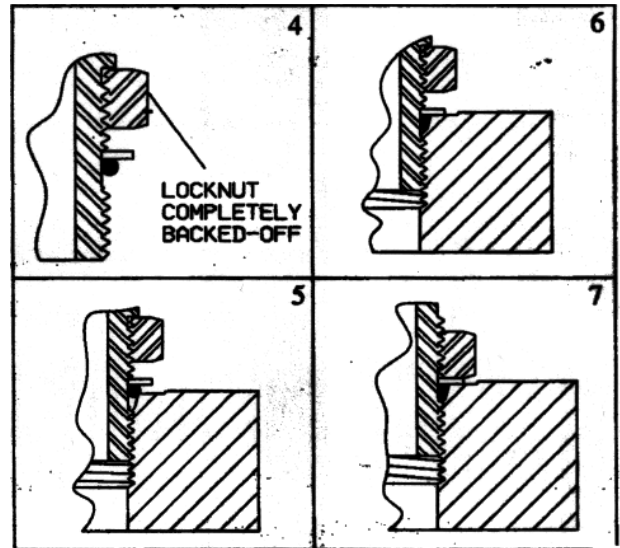

NOTE - ft-lb may be converted to Newton Meters by multiplying by 1.35582.

NOTE - in-lbs may be converted to Newton Meters by multiplying by 0.11298.

GLOSSARY

angle or angle assembly - portion of the sweeper that allows the brush head assembly to angle.

BP - black pipe.

brush head assembly - assembly that includes the core, hood, and brush frame.

brush pattern - area of dirt removed from sweeping surface; with a properly adjusted sweeper; the pattern is the same width for the entire length.

castellated - having battlements like a castle.

caution - indicates a potentially hazardous situation which, if not avoided, may result in minor or moderate injury.

core - weldment that holds brush sections.

danger - indicates an imminently hazardous situation which, if not avoided, will result in death or serious injury.

F - female.

FS - face seal.

front - side that is in front when facing the normal forward direction of travel of the machine.

gpm - gallons per minute.

HP - high pressure.

hood - brush shield.

hydraulic angle kit - means of swinging an assembly hydraulically

in. - inch.

kph - kilometers per hour.

lb - pounds.

left-hand - side that is on left when facing the normal forward direction of travel of the machine.

lift cylinder - means of raising the brush head assembly hydraulically.

lps - liters per second.

M - male.

mm - millimeters.

mph - miles per hour.

manual angle kit - means of swinging the brush head assembly mechanically.

mounting assembly - portion of the sweeper that attaches to the primer mover; designed specifically for each prime mover.

NPT - national pipe thread.

note - indicates supplementary information.

notice - used for instructions when machine damage may be involved.

psi - pounds per square inch.

PTO - power take off; shaft on the prime mover used to drive attachments.

prime mover - refers to the tractor, truck, loader or other vehicle to which a sweeper is attached.

qty - quantity.

quick change core - core designed in a way that allows brush sections to be changed without removing hoses from motors.

rpm - revolutions per minute.

rear - side that is in the rear when facing the normal forward direction of travel of the machine.

retainer - removable plate or set of plates that keep sections on the core.

right-hand - side that is on the right when facing the normal forward direction of travel of the machine.

GLOSSARY

section - single brush wafer.

section set - replacement brush wafers.

sprinkler system - system that sprays water ahead of the sweeper used to reduce dust.

sprinkler tank - assembly that includes the water reservoir and mounting used in a sprinkler system.

stands - devices designed to keep the components off the ground when the sweeper is dismounted.

swing cylinder - means of angling the brush head assembly hydraulically.

warning - indicates a potentially hazardous situation which, if not avoided, could result in death or serious injury.

weld - weldment.

windrow - pile of debris.

zerk - grease fitting.

WARRANTY

Limited Warranty

Except for the Excluded Products as described below, all new products are warranted to be free from defects in material and/or workmanship during the Warranty Period, in accordance with and subject to the terms and conditions of this Limited Warranty.

1. Excluded Products. The following products are excluded from this Limited Warranty:

(a) Any cable, part that engages with the ground (i.e. sprockets), digging chain, bearing, teeth, tamping and/or demolition head, blade cutting edge, pilot bit, auger teeth and broom brush that either constitutes or is part of a product.

(b) Any product, merchandise or component that, in the opinion of Paladin Light Construction¹, has been (i) misused; (ii) modified in any unauthorized manner; (iii) altered; (iv) damaged; (v) involved in an accident; or (vi) repaired using parts not obtained through Paladin Light Construction.

2. Warranty Period. The Limited Warranty is provided only to those defects that occur during the Warranty Period, which is the period that begins on the first to occur of: (i) the date of initial purchase by an end-user, (ii) the date the product is first leased or rented, or (iii) the date that is six (6) months after the date of shipment by Paladin Light Construction as evidenced by the invoiced shipment date (the "Commencement Date") and ends on the date that is twelve (12) months after the Commencement Date.

3. Terms and Conditions of Limited Warranty. The following terms and conditions apply to the Limited Warranty hereby provided:

(a) Option to Repair or Replace. Paladin Light Construction shall have the option to repair or replace the product.

(b) Timely Repair and Notice. In order to obtain the Limited Warranty, (i) the product must be repaired within thirty (30) days from the date of failure, and (ii) a claim under the warranty must be submitted to Paladin Light Construction in writing within thirty (30) days from the date of repair.

(c) Return of Defective Part or Product. If requested by Paladin Light Construction, the alleged defective part or product shall be shipped to Paladin Light Construction at its manufacturing facility or other location specified by Paladin Light Construction, with freight PRE-PAID by the claimant, to allow Paladin Light Construction to inspect the part or product.

Claims that fail to comply with any of the above terms and conditions shall be denied.

LIMITATIONS AND EXCLUSIONS.

THIS LIMITED WARRANTY IS IN LIEU OF ALL OTHER WARRANTIES, EXPRESS OR IMPLIED, INCLUDING WITHOUT LIMITATION THE WARRANTIES OF MERCHANTABILITY, FITNESS FOR A PARTICULAR PURPOSE AND ANY WARRANTY BASED ON A COURSE OF DEALING OR USAGE OF TRADE.

IN NO EVENT SHALL PALADIN LIGHT CONSTRUCTION BE LIABLE FOR CONSEQUENTIAL OR SPECIAL DAMAGES.

IN NO EVENT SHALL PALADIN LIGHT CONSTRUCTION BE LIABLE FOR ANY LOSS OR CLAIM IN AN AMOUNT IN EXCESS OF THE PURCHASE PRICE, OR, AT THE OPTION OF PALADIN LIGHT CONSTRUCTION, THE REPAIR OR REPLACEMENT, OF THE PARTICULAR PRODUCT ON WHICH ANY CLAIM OF LOSS OR DAMAGE IS BASED. THIS LIMITATION OF LIABILITY APPLIES IRRESPECTIVE OF WHETHER THE CLAIM IS BASED ON BREACH OF CONTRACT, BREACH OF WARRANTY, NEGLIGENCE OR OTHER CAUSE AND WHETHER THE ALLEGED DEFECT IS DISCOVERABLE OR LATENT.

¹Attachment Technologies Inc., a subsidiary of Paladin Brands Holding, Inc. (PBHI) is referred to herein as Paladin Light Construction.

February 10, 2010