

MASCHIO GASPARDO S.p.A.

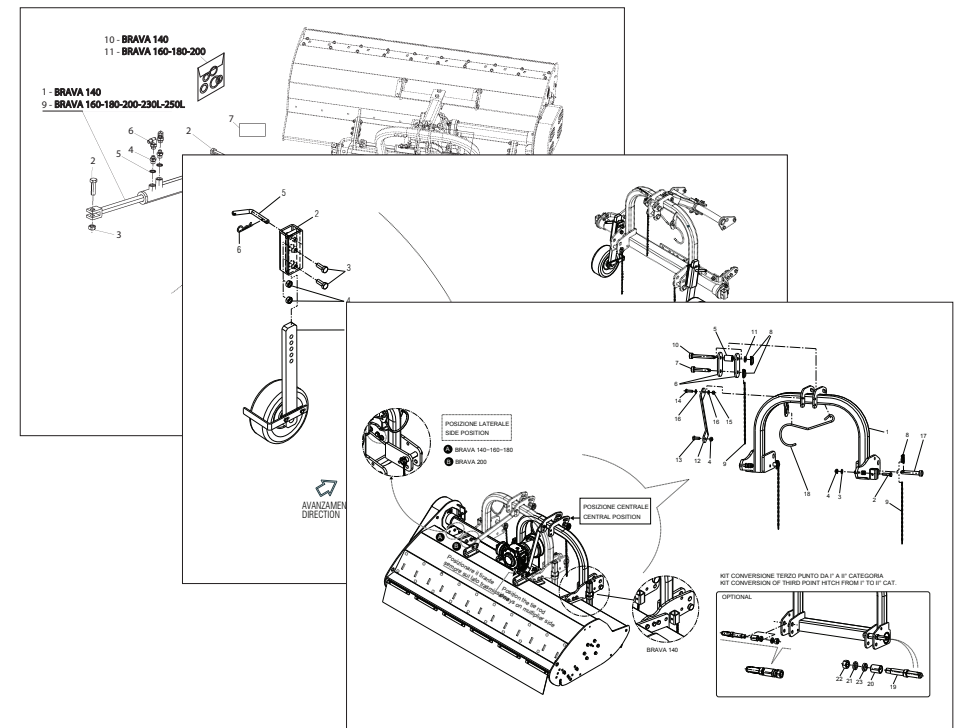

BRAVA

Cod: F07021036 2015-05

- *) Valido per Paesi UE
- *) Valid for EU member countries
- *) Valable dans les Pays UE
- *) Gilt für EU-Mitgliedsländer
- *) Válido para Países UE

- IT** PARTI DI RICAMBIO
- EN** SPARE PARTS
- DE** ERSATZTEILE
- FR** PIÈCES DÉTACHÉES
- ES** PIEZAS DE REPUESTO

PARTI DI RICAMBIO

Le ordinazioni delle parti di ricambio vanno fatte presso i nostri concessionari di zona e devono essere sempre corredate dalle seguenti indicazioni:

- **Tipo, modello e numero di matricola dell'attrezzatura.** Tali dati sono stampigliati nell'apposita targhetta di cui è dotata ogni attrezzatura.
- **Numero di codice della parte richiesta** rilevabile dal catalogo ricambi.
- **Descrizione del particolare e quantità richiesta.**
- **Numero della tavola.**
- **Mezzo di trasporto.** Nel caso questa voce non sia specificata, la Ditta Costruttrice, pur dedicando a questo servizio una particolare cura, non risponde di eventuali ritardi di spedizione dovuti a cause di forza maggiore. Le spese di trasporto si intendono sempre a carico del destinatario. La merce viaggia a rischio e pericolo del committente anche se venduta franco destino.

NOTA: Il termine **(Dx) Destro** o **(Sx) Sinistro** della macchina o di parti di essa, è inteso guardando la macchina dalla parte posteriore. Le eccezioni saranno indicate.

SPARE PARTS

Orders must be transmitted through our area dealers and should always include the following indications:

- **Type, model and serial number of the machine.** *These data are punched on the data plate with which every implement is equipped.*
- **Code number of the required spare part.** *This will be found in the spare parts catalogue.*
- **Description of the part and required quantity.**
- **Table number.**
- **Means of dispatch.** *If this item is not indicated, the Manufacturer, while dedicating particular care to this service, shall not be held responsible for delays in delivery caused by cases of force majeure. Transport expenses shall always be at the consignee's charge. The goods travel at the purchaser's risk and peril even when sold ex destination.*

NOTE: *The symbols (Dx) right and (Sx) left, concerning the machine or single parts of it, are referred, as in the figure, to a rear view of them. Exceptions will be indicated.*

ERSATZTEILE

Die Bestellungen müssen bei unseren Gebietshändlern aufgegeben werden. Bei der Bestellung sind stets die folgenden Angaben zu machen:

- **Typ, Modell und Serien-Nummer des Geräts.** Diese Daten stehen auf dem Typenschild, mit dem jedes Gerät versehen ist.
- **Artikel Nr. der erforderlichen Ersatzteile.** Diese stehen im Ersatzteil-Katalog.
- **Beschreibung des Ersatzteils und die erforderliche Stückzahl.**
- **Tafelnummer.**
- **Versandmittel.** Wenn dieser Punkt nicht spezifiziert wird, haftet die Herstellerfirma nicht für etwaigen Lieferverzug aufgrund höherer Gewalt, auch wenn er diesen Service besonders aufmerksam abwickelt. Die Frachtkosten gehen dagegen immer zu Lasten des Empfängers. Die Ware reist auf Gefahr und Risiko des Auftraggebers, auch wenn frei Haus Verkauft vereinbart worden ist.

N.B.: Die Merkzeichen **(Dx) rechts** und **(Sx) links** betreffen eine rückwärtige Aussicht der Maschine oder Teile von ihr (siehe Bild). Ausnahmen werden gezeigt.

PIECES DÉTACHÉES

Les ordres doivent être effectués auprès de nos concessionnaires de zone en précisant les indications suivantes:

- **Type, modèle et numéro de série de la machine.** *Ces données sont gravées sur la plaque d'identification de chaque outil.*
- **Numéro de code de la pièce détachée** indiqué sur le catalogue des pièces détachées.
- **Description de la pièce et quantité requise.**
- **Numéro de plan.**
- **Moyen d'expédition.** *Si cette rubrique n'est pas indiquée, le Constructeur, bien que soucieux de ce service, ne répond pas des retards d'expédition pour des causes de force majeure. Les frais de transport sont toujours à la charge du destinataire. La marchandise voyage aux risques et périls de l'acheteur même si vendue franco de port.*

N.B.: *Les références (Dx) droit et (Sx) gauche de la machine ou des parties de la même, est entendue, comme de la figure, en regardant la machine de derriere dans le sens de marche.*

RESPUESTOS

Los pedidos han de efectuarse en nuestros concesionarios de zona y deben incluir siempre las siguientes indicaciones:

- **Tipo, modelo y número de matrícula del equipo.** Dichos datos están impresos en la relativa placa presente en el equipo.
- **Número de código de la parte requerida** presente en el catálogo respuestos.
- **Descripción de la pieza y cantidad requerida.**
- **Numero de ilustración.**
- **Medio de transporte.** En caso que este ítem no esté especificado, el Fabricante, aún prestando la debidas consideraciones para este aspecto, no responde por eventuales retardos de env'o debidos a causas de fuerza mayor. Los gastos de transporte se consideraran siempre a cargo del destinatario. La mercadería viaja bajo riesgo y peligro del comprador, incluso cuando se vende franco destino.

N.B.: La referencia **(Dx) derecha** o **(Sx) izquierda** de la máquina o de sus componentes, se entiende, como en la figura, mirando la máquina por la parte trasera. Se indicarán las excepciones.

INDICE

<i>N° Tavola</i>	<i>Descrizione</i>	<i>Pagina</i>
TAV. 010	Terzo punto fisso.....	4
TAV. 020	Terzo punto spostabile.....	6
TAV. 030	Telaio, moltiplicatore e slitte (opt.).....	8
TAV. 040	Esploso moltiplicatore MASCHIO.....	10
TAV. 050	Esploso moltiplicatore BONDIOLI.....	12
TAV. 060	Trasmissione laterale.....	14
TAV. 070	Rotore ed utensili.....	16
TAV. 080	Rullo posteriore.....	18
TAV. 090	Protezioni di sicurezza.....	20
TAV. 100	Impianto idraulico.....	22
TAV. 110	Lamiera antiusura e denti di raccolta.....	24
TAV. 120	Ruote anteriori.....	26
TAV. 130	Albero cardanico Walterscheid BRAVA 100/120.....	28
TAV. 140	Albero cardanico Walterscheid BRAVA 140/160/180/200.....	30
TAV. 150	Albero cardanico Bondioli BRAVA 140/160/180/200.....	32

INDEX

<i>N° Table</i>	<i>Description</i>	<i>Page</i>
TAV. 010	Fixed third point.....	4
TAV. 020	Offset third point.....	6
TAV. 030	Frame, complete gearbox and optional skids.....	8
TAV. 040	MASCHIO Gearbox exploded drawing.....	10
TAV. 050	BONDIOLI Gearbox exploded drawing.....	12
TAV. 060	Side transmission.....	14
TAV. 070	Rotor and blades.....	16
TAV. 080	Rear roller.....	18
TAV. 090	Protections.....	20
TAV. 100	Hydraulic plant.....	22
TAV. 110	Double skin and collecting rakes kits.....	24
TAV. 120	Front wheels.....	26
TAV. 130	Walterscheid cardan shaft BRAVA 100/120.....	28
TAV. 140	Walterscheid cardan shaft BRAVA 140/160/180/200.....	30
TAV. 150	Bondioli cardan shaft BRAVA 140/160/180/200.....	32

TAV. 010

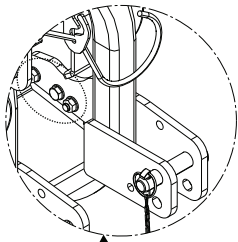
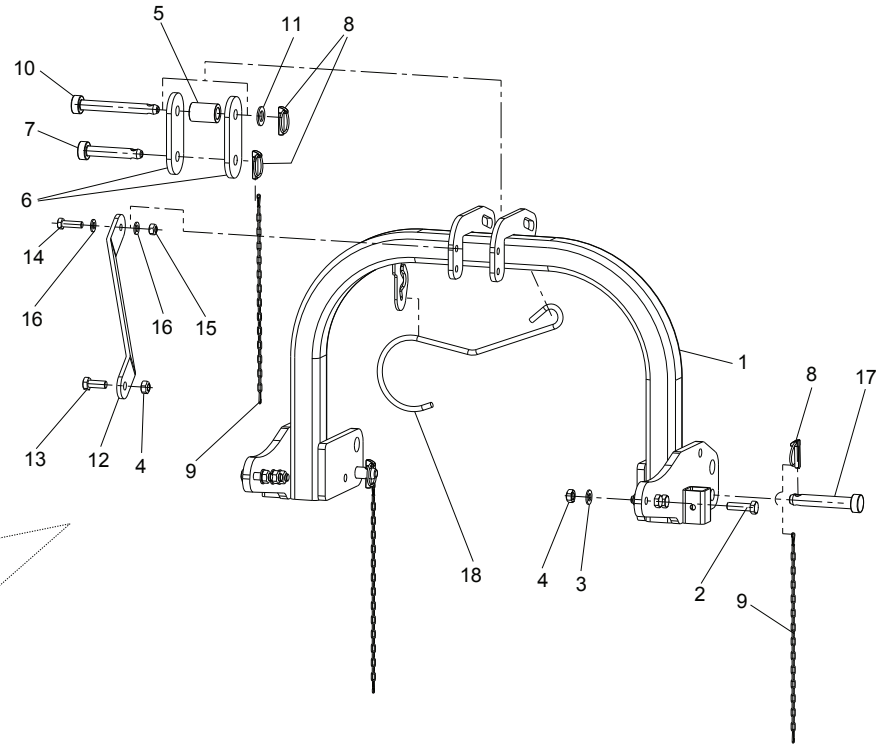

POSIZIONE LATERALE
SIDE POSITION

A BRAVA 140-160-180

B BRAVA 200

POSIZIONE CENTRALE
CENTRAL POSITION

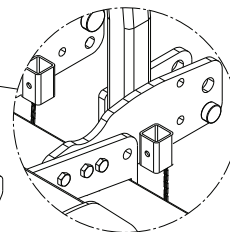
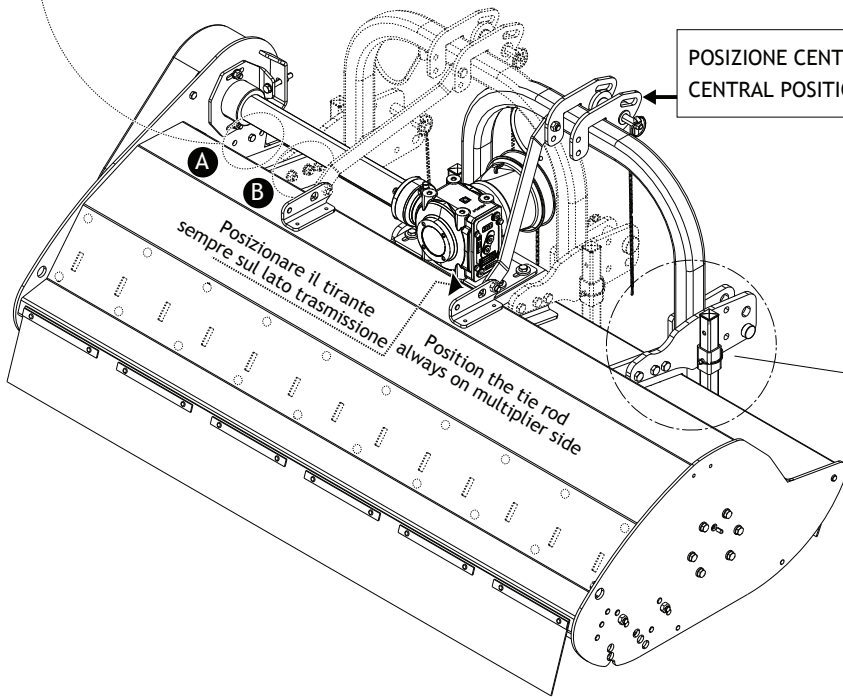

BRAVA 140

KIT CONVERSIONE TERZO PUNTO DA I° A II° CATEGORIA
KIT CONVERSION OF THIRD POINT HITCH FROM I° TO II° CAT.

OPTIONAL

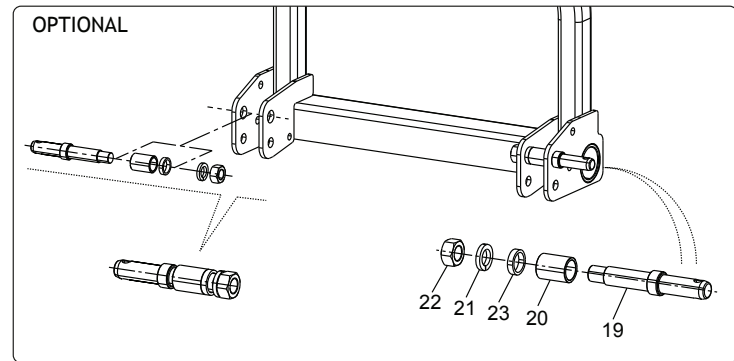

**TERZO PUNTO FISSO
FIXED THIRD POINT**

TAV. 010

Pos.	Cod.	Descrizione	Description	Benennung	Description	Description
1	M14700539R	CASTELLO TERZO P FISSO BRAVA	THIRD POINT HITCH FIXED			
2	F01010082R	VITE M14X1,5X50 U5738 8.8ZN	SCR. M14X1,5X50 U5738 8.8ZN	VIS M14X1.5X50 ZN	SCHRA.M14X1.5X50 U5738 8.8 ZN	TORN. M14X1.5X50 U5738 8.8 ZN
3	F01410088R	ROS.M14 15X 28X2,5 U6592 ZN	WAS.M14 15X 28X2,5 U6592 ZB	RON.M14 15X 28X2,5 U6592 ZB	SCH.M14 15X 28X2,5 U6592 ZB	ARA.M14 15X 28X2,5 U6592 ZB
4	F01220059R	DADO M14X1,5 D980 8ZN	NUT M14X1,5 D980 8ZN	ECROU M14X 1,5 D980 8 ZN	MUTTER M14X 1,5 D980 8 ZN	TUERCA M14X 1,5 D980 8 ZN
5	M73100911R	BUSSOLA	BUSH	BOUSSOLE	DISTANZBUECHSE	BRUJULA
6	M33400568R	BIELLA	CONNECTING ROD	BIELLE	PLEUEL	BIELA
7	F20100035R	PERNO D19 L90 C43 TEST.D35 ZN	BOLT D19 L86 C43 ZN	BOULON D19 L86 C43	BOLZEN D19 L86 C43	PERNO D19 L86 C43
8	F02200529R	SPINA SCATTO D.11 H58 ZN	SNAP PIN D.11 H58 ZN	FICHE A DETENTE D.11 H58 ZN	EINRASTSTIFT D.11 H58 ZN	CLAVIJA DE MUELLE D.11 H58 ZN
9	M58100930R	CATENELLA L=476	ASSEMBLY CHAIN DMP L=476	CHAINE L=476	KETTE L=476	CADENA L=476
10	F20100033R	PERNO D19 L137 C43 TEST.D35 ZN	BOLT D=19 L=137	GOUJON D=19 L=137	STIFT D=19 L=137	PERNO D=19 L=137
11	F01410124R	ROS.M20 21X 37X 3 U6592 ZN	WASHER M20 21X 37X 3 U6592 ZN	RONDEL.M20 21X37X3 ZN	MUTTER M20 21X 37X 3 U6592 ZN	ARAND.M20 21X 37X 3 U6592 ZN
12	M14700545R	TIRANTE 3 P CASTELLO FISSO	THIRD POINT HITCH TIE FIX.			
13	F01010317R	VITE M14X1,5X35 U5740 8.8ZN	SCR. M14X1,5X35 U5740 8.8ZN	VIS M 14X1,5X35	SCHRAUBE M 14X1,5X35	TORNILLO M 14X1,5X35
14	F01010291R	VITE M12X1,25X40 U5740 8.8ZN	SCR. M12X1,25X40 U5740 8.8ZN	VIS M12X1,25X40 U5740 8.8 ZN	SCHR.M12X1,25X40 U5740 8.8 ZN	TORN. M12X1,25X40 U5740 8.8 ZN
15	F01220047R	DADO M12X1,25 D980 8ZN	NUT M12X1,25 D980 8ZN	ECROU M12X1,25 D980 8 ZN	MUTTER M12X1,25 D980 8 ZN	TUERCA M12X1,25 D980 8 ZN
16	F01410076R	ROS.M12 13X 24X2,5 U6592 ZN	WASHER 12 13X 24X2,5 U6592 ZN	RONDEL. M12 13X24X2,5 U6592 ZN	SCHEIBE M12 13X24X2,5 U6592 ZN	ARAND.M12 13X 24X2,5 U6592 ZN
17	F20100047R	PERNO D22 L108 C43 TEST.D35 ZN	BOLT D22 L108 C43 ZN	GOUJON SUPPORT	BOLZEN	PERNO SOPORTE
18	F20120400R	GANCIO SOSTEGNO CARDANO	SHAFT HOOK SUPPORT	SUPPORT CARDAN	GELENKWELLE - HACKEN	SOPORTE CARDAN
19	T16004050R	PERNO TRASF.AT.BARRE I C.2 ZG	BAR LINKAGE TRANSF.PIN 1-2CAT			
20	T16004051R	BOCCOLA 38X49,5X30 ZG	BUSHING 38X49,5X30 ZN			
21	F01480189R	ROS.G 25X39,5X 6 FLZNNC-240H	GROWER WASHER D.24	RONDELLE GROWER D.24	SCHEIBE GROWER D.24	ARANDELA GROWER D.24
22	F01200377R	DADO M24X2 U5588 CL8 ZN 6.8ZN	NUT M24X2 U5588 6.8ZN	ECROU M24X2 U5586 6.8 ZN	MUTTER M24X2 U5588 6.8 ZN	TUERCA M24X2 U5588 6.8 ZN
23	M72100817R	DISTANZIALE D=38 D=30 L=9	SPACER	ENTRETOISE	DISTANZSTUECK	DISTANCIADOR

1 - BRAVA 140
43 - BRAVA 160/180/200

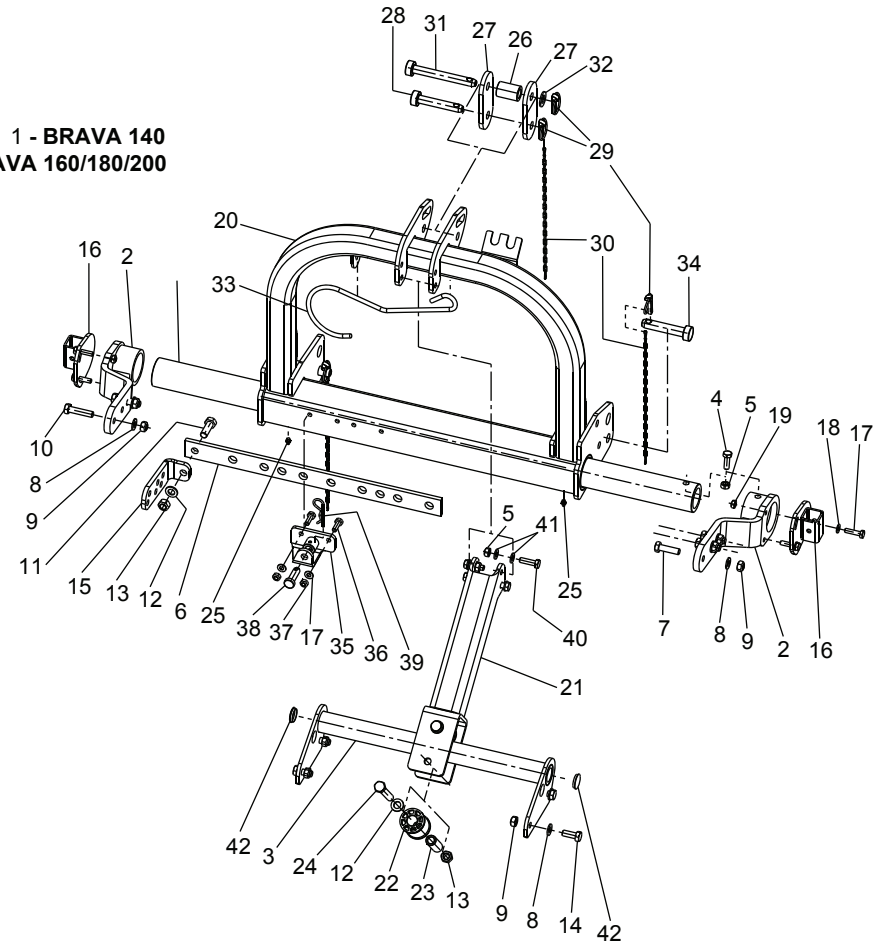
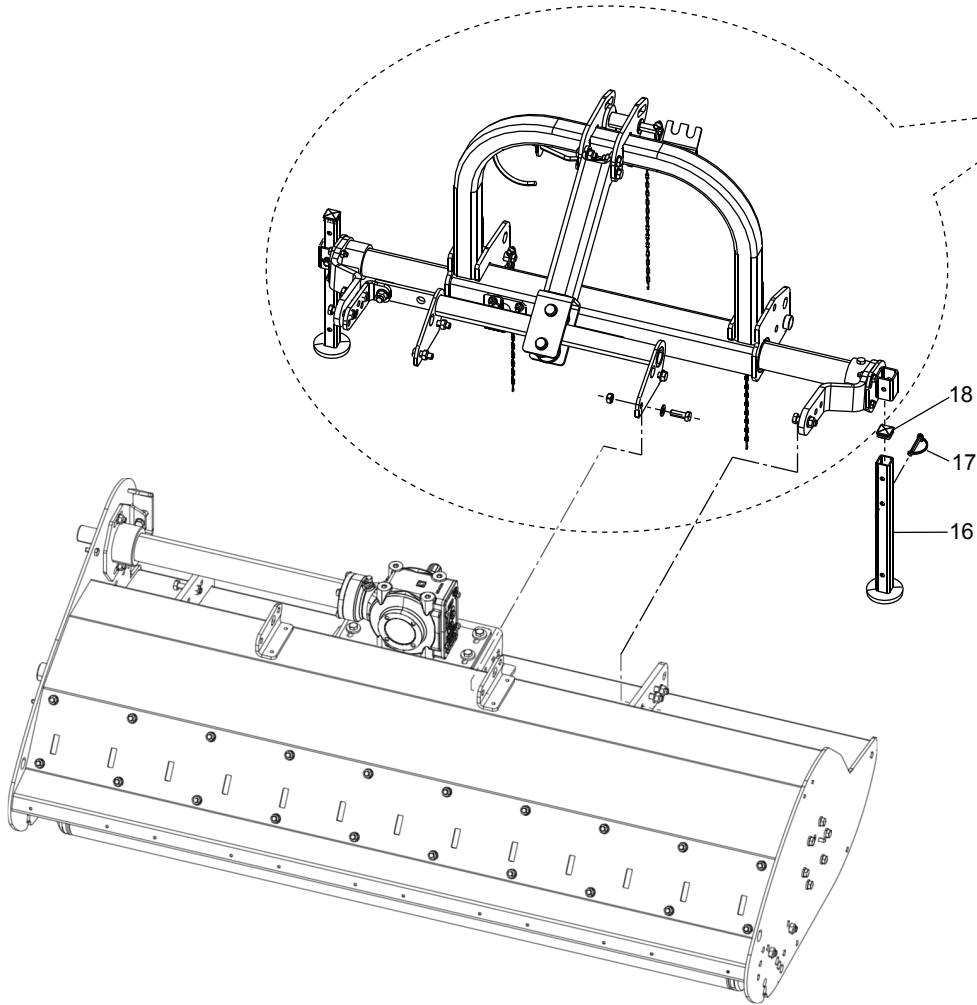

KIT CONVERSIONE TERZO PUNTO DA I° A II° CATEGORIA
KIT CONVERSION OF THIRD POINT HITCH FROM I° TO II° CAT.

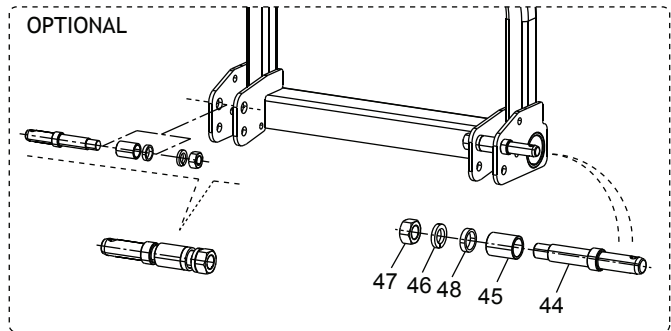

**TERZO PUNTO SPOSTABILE
OFFSET THIRD POINT**

TAV. 020

Pos.	Cod.	Descrizione	Description	Benennung	Description	Descrpcion
1	M24414533R	ASTA SCORRIMENTO L=1287	SLIDING ROD L=1287	TIGE DE GLISSEMENT L=1287	GLEITSTANGE L=1287	BARRA DESLIZAMIENTO L=1287
2	M14700541R	CENTINA SPOSTAMENTO AVVITATA	OFFSET BOLTED PLATE			
3	M14700537R	SCORRIMENTO TERZO PUNTO	THIRD POINT OFFSET BAR ASS.			
4	F01010288R	VITE M12X1,25X35 U5740 8.8ZN	SCR. M12X1,25X35 U5740 8.8ZN	VIS M12X1,25X35 U5740 8.8 ZN	SCHR.M12X1,25X35 U5740 8.8 ZN	TORN.M12X1,25X35 U5740 8.8 ZN
5	F01220047R	DADO M12X1,25 D980 8ZN	NUT M12X1,25 D980 8ZN	ECROU M12X1,25 D980 8 ZN	MUTTER M12X1,25 D980 8 ZN	TUERCA M12X1,25 D980 8 ZN
6	M34400516R	ASTA SPOST.MECCANICO	MECH. OFFSET BAR	MECH. OFFSET MECAN.	MECH.VERSCHIEBUNG STANGE	
7	F01010082R	VITE M14X1,5X50 U5738 8.8ZN	SCR. M14X1,5X50 U5738 8.8ZN	VIS M14X1,5X50 ZN	SCHRA.M14X1,5X50 U5738 8.8 ZN	TORN. M14X1,5X50 U5738 8.8 ZN
8	F01410088R	ROS.M14 15X 28X2,5 U6592 ZN	WAS.M14 15X 28X2,5 U6592 ZB	RON.M14 15X 28X2,5 U6592 ZB	SCH.M14 15X 28X2,5 U6592 ZB	ARA.M14 15X 28X2,5 U6592 ZB
9	F01220059R	DADO M14X1,5 D980 8ZN	NUT M14X1,5 D980 8ZN	ECROU M14X 1,5 D980 8 ZN	MUTTER M14X 1,5 D980 8 ZN	TUERCA M14X 1,5 D980 8 ZN
10	F01010088R	VITE M14X1,5X60 U5738 8.8ZN	SCR. M14X1,5X60 U5738 8.8ZN	VIS M 14X1,5X60	SCHRAUBE M 14X1,5X60	TORNILLO M 14X1,5X60
11	F01010341R	VITE M16X1,5X45 U5740 8.8ZN	SCR. M16X1,5X45 U5740 8.8ZN	VIS M16X1,5 X45 U5740 8.8 ZN	SCHR.M16X1,5 X45 U5740 8.8 ZN	TORN.M16X1,5 X45 U5740 8.8 ZN
12	F01410100R	ROS.M16 17X 30X 3 U6592 ZN	WASHER M16 17X30X3 U6592 ZN	RONDELLE M16 17X30X3 ZN	SCHRAUBE M16 17X 30X3 U6592 ZN	ARAND.M16 17X 30X 3 U6592 ZN
13	F01220070R	DADO M16X1,5 D980 10ZN	NUT M16X1,5 D980 8ZN	ECRO.M16X1,5 D980 8ZN	MUTTER M16X1,5 D980 8ZN	TUER.M16X1,5 D980 8ZN
14	F01010317R	VITE M14X1,5X35 U5740 8.8ZN	SCR. M14X1,5X35 U5740 8.8ZN	VIS M 14X1,5X35	SCHRAUBE M 14X1,5X35	TORNILLO M 14X1,5X35
15	M14700532R	STAFFA SPOSTAMENTO MANUALE	BRACKET JOG			
16	M14700558R	ANCORAGGIO PIEDINO	ANCHORAGE LEG			
17	F01010039R	VITE M10X1,25X40 U5740 10.9ZD	SCR. M10X1,25X40 U5740 10.9ZD	VIS M 10X1,25X40 U5740 10.9ZD	SCHRA.M10X1,25X40 U5740 10.9ZD	TORN. M10X1,25X40 U5740 10.9ZD
18	F01410064R	ROS.M10 10,5X 20X 2 U6592 ZN	WASHER M10 10,5X20X2 U6592 ZN	RONDEL. M10 10,5X20X2 U6592 ZN	SCHEIBE M10 10,5X20X2 U6592 ZN	ARAND.M10 10,5X 20X 2 U6592 ZN
19	F01220033R	DADO M10X1,5 D980 8ZN	NUT M10X1,5 D980 8ZN	ECROU M10X1,5 D980 8ZN	MUTTER M10X1,5 D980 8ZN	TUERCA M10X1,5 D980 8
20	M14700522R	CASTELLO TERZO PUNTO BRAVA	THREE POINT HITCH			
21	M14700560R	TIRANTE TERZO PUNTO BRAVA	THIRD POINT TIE			
22	M25400542R	RULLINO DI SCORRIMENTO	SLIDING ROLLER	ROLLER DE GLISSE	ROLLER	RODILLO DESLIZAMIENTO
23	M03400939R	DISTANZ. D=25 D=16,5 L=72	SPACER D=25 D=16,5 L=72	ENTRETOISE D=25 D=16,5 L=72	DISTANZSTUECK D=25 D=16,5 L=72	DISTANCIADOR D=25 D=16,5 L=72
24	F01010126R	VITE M16X1,5X110 U5738 8.8ZN	SCR. M16X1,5X110 U5738 8.8ZN	VIS M 16X1,5X110	SCHRAUBE M 16X1,5X110	TORNILLO M 16X1,5X110
25	F01100048R	ING.M 8X1,25 7663A 9SMNPB28 Z	GREASE NIPPLE M8X1,25 U7663A	GRAISSEUR A BILLES M8X1,25	SCHMIERBUECHSE M8X1,25 7663A	ENG.M 8X1,25 7663A 9SMNPB28 Z
26	M73100911R	BUSSOLA	BUSH	BOUSSOLE	DISTANZBUECHSE	BRUJULA
27	M33400568R	BIELLA	CONNECTING ROD	BIELLE	PLEUEL	BIELA
28	F20100035R	PERNO D19 L90 C43 TEST.D35 ZN	BOLT D19 L86 C43 ZN	BOULON D19 L86 C43 ZN	BOLZEN D19 L86 C43	PERNO D19 L86 C43
29	F02200529R	SPINA SCATTO D.11 H58 ZN	SNAP PIN D.11 H58 ZN	FICHE A DETENTE D.11 H58 ZN	EINRASTSTIFT D.11 H58 ZN	CLAVIJA DE MUELLE D.11 H58 ZN
30	M58100930R	CATENELLA L=476	ASSEMBLY CHAIN DMP L=476	CHAINE L=476	KETTE L=476	CADENA L=476
31	F20100033R	PERNO D19 L137 C43 TEST.D35 ZN	BOLT D=19 L=137	GOUJON D=19 L=137	STIFT D=19 L=137	PERNO D=19 L=137
32	F01410124R	ROS.M20 21X 37X 3 U6592 ZN	WASHER M20 21X 37X 3 U6592 ZN	RONDEL.M20 21X37X3 ZN	MUTTER M20 21X 37X 3 U6592 ZN	ARAND.M20 21X 37X 3 U6592 ZN
33	F20120400R	GANCIO SOSTEGNO CARDANO	SHAFT HOOK SUPPORT	SUPPORT CARDAN	GELENKWELLE - HACKEN	SOPORTE CARDAN
34	F20100049R	PERNO D22 L86 C43 TEST.D35 ZN	BOLT D22 L86 C43 ZN	GOUJON D.22	BOLZEN D.22	PERNO D.22
35	M14700533R	SUPPORTO CILINDRO AVVITATO	BOLTED CYLINDER SUPPORT			
36	F01010250R	VITE M10X1,25X30 U5740 8.8ZN	SCR. M10X1,25X30 U5740 8.8ZN	VIS M10X1,25X30 U5740 8.8 ZB	SCHR.M10X1,25X30 U5740 8.8 ZB	TORN.M10X1,25X30 U5740 8.8 ZB
37	F01220034R	DADO M10X1,25 D980 8ZN	NUT M10X1,25 D980 8ZN	ECRO.M10X1,25 D980 8 ZB	MUTT.M10X1,25 D980 8 ZB	TUER.M10X1,25 D980 8 ZB
38	M38100573R	PERNO DI REGOLAZIONE ZGPD	PIN	GOUJON	BOLZEN	PERNO
39	F02200374R	COPIGLIA R 4X 82 ZN	SPRING SPLIT PIN 4X82	GOUPILLE 4X82	SPLINT 4X82	PASADOR 4X82
40	F01010291R	VITE M12X1,25X40 U5740 8.8ZN	SCR. M12X1,25X40 U5740 8.8ZN	VIS M12X1,25X40 U5740 8.8 ZN	SCHR.M12X1,25X40 U5740 8.8 ZN	TORN. M12X1,25X40 U5740 8.8 ZN
41	F01410076R	ROS.M12 13X 24X2,5 U6592 ZN	WASHER 12 13X 24X2,5 U6592 ZN	RONDEL. M12 13X24X2,5 U6592 ZN	SCHEIBE M12 13X24X2,5 U6592 ZN	ARAND.M12 13X 24X2,5 U6592 ZN
42	F05100019R	TAPPO AD ALETTA D. 34 PLT	PLUG D. 34 PLT	BOUCHON FERMETURE D.34	VERSCHLUSSPFROPFEN D.34	TAPON CLAUSURA D.34
43	M24418533R	ASTA SCORRIMENTO L=1420	SLIDING ROD L=1420	TIGE DE GLISSEMENT L=1420	GLEITSTANGE L=1420	BARRA DESLIZAMIENTO L=1420
44	T16004050R	PERNO TRASF.AT.BARRE I C.2 ZG	BAR LINKAGE TRANSF.PIN 1-2CAT			
45	T16004051R	BOCCOLA 38X49,5X30 ZG	BUSHING 38X49,5X30 ZN			
46	F01480189R	ROS.G 25X39,5X 6 FLZNNC-240H	GROWER WASHER D.24	RONDELLE GROWER D.24	SCHEIBE GROWER D.24	ARANDELA GROWER D.24
47	F01200377R	DADO M24X2 U5588 CL8 ZN 6.8ZN	NUT M24X2 U5588 6.8ZN	ECROU M24X2 U5588 6.8 ZN	MUTTER M24X2 U5588 6.8 ZN	TUERCA M24X2 U5588 6.8 ZN
48	M72100817R	DISTANZIALE D=38 D=30 L=9	SPACER	ENTRETOISE	DISTANZSTUECK	DISTANCIADOR

TAV. 030

BONDIOLI	MASCHIO
7 - BRAVA 100/120	10 - BRAVA 100/120
8 - BRAVA 140/160/180	11 - BRAVA 140/160/180
9 - BRAVA 200	12 - BRAVA 200

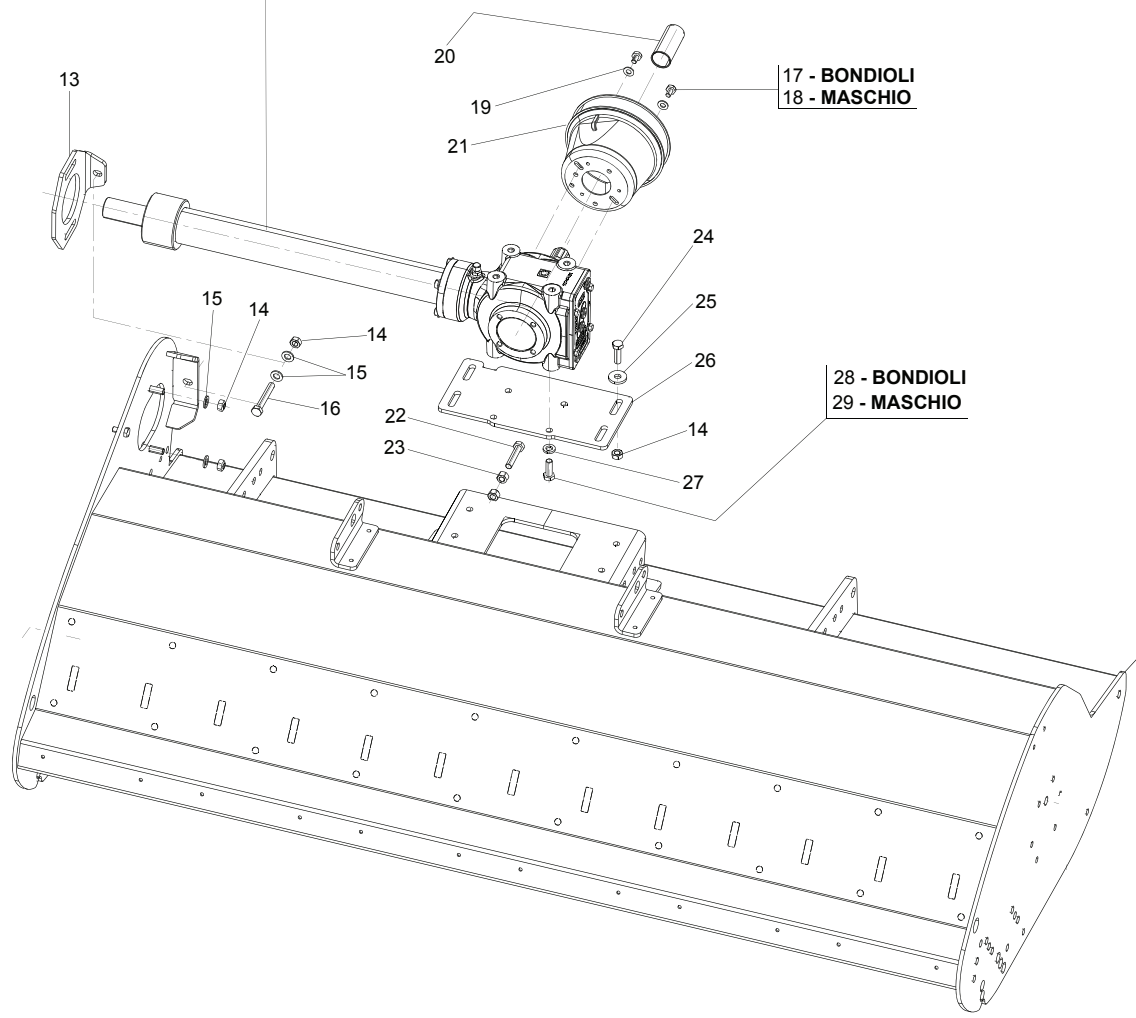

17 - BONDIOLI
18 - MASCHIO

28 - BONDIOLI
29 - MASCHIO

1 - BRAVA 100
2 - BRAVA 120
3 - BRAVA 140
4 - BRAVA 160
5 - BRAVA 180
6 - BRAVA 200

COPPIA DI SLITTE PAIR OF SKIDS

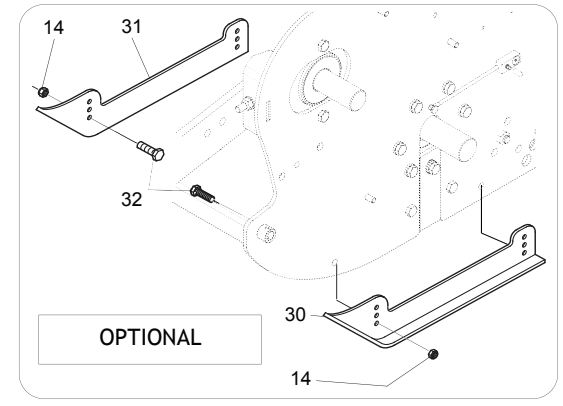

**TELAIO, MOLTIPLICATORE E SLITTE (OPT.)
GEARBOX, FRAME AND OPTIONAL SKIDS**

TAV. 030

Pos.	Cod.	Descrizione	Description	Benennung	Description	Description
1	M14710501R	TELAIO BRAVA 100	FRAME BRAVA			
2	M14712501R	TELAIO BRAVA 120	FRAME BRAVA 120			
3	M14714501R	TELAIO BRAVA 140	FRAME BRAVA			
4	M14716501R	TELAIO BRAVA 160	FRAME BRAVA			
5	M14718501R	TELAIO BRAVA 180	FRAME BRAVA			
6	M14720501R	TELAIO BRAVA 200	FRAME BRAVA			
7	M28412202R	CORPO MOLT.540 RPM L=500	GEARBOX 540 RPM L=500			
8	M28415202R	CORPO MOLT.540 RPM L=616	COMPL.GEARBOX L=616	BOITE DE VITESSE COMPL.L=616	WECHSELGETRIEBE KOMPL.L=616	CAJA CAMBIO COMPLETA L=616
9	M28419202R	CORPO MOLT.540 RPM L=780	COMPL.GEARBOX L=780	BOITE DE VITESSE COMPL.L=780	WECHSELGETRIEBE KOMPL.L=780	CAJA CAMBIO COMPLETA L=780
10	T24121300R	SCATOLA CAM. PROL.L=500 BRAVA	GEARBOX WITH EXTENSION L=500	BOITE VITESSE AVEC ENTR. L=500	WECHS.MIT DISTANZSTUECK L=500	CAJA CAMBIO DISTANCIADOR L=500
11	T24151300R	SCATOLA CAM. PROL.L=615 VARIE	GEARBOX WITH EXTENSION L=615	BOITE VITESSE AVEC ENTR. L=615	WECHS.MIT DISTANZSTUECK L=615	CAJA CAMBIO DISTANCIADOR L=615
12	T24191300R	SCATOLA CAM. PROL.L=780 VARIE	GEARBOX WITH EXTENSION L=780	BOITE VITESSE AVEC ENTR. L=780	WECHS.MIT DISTANZSTUECK L=780	CAJA CAMBIO DISTANCIADOR L=780
13	T16005526R	SUPPORTO TENDICINGHIA	BELT STRETCHER	SUPPORT TENDEUR DE COURROIE	HALTERUNG	SOPORTE
14	F01220047R	DADO M12X1,25 D980 8ZN	NUT M12X1,25 D980 8ZN	ECROU M12X1,25 D980 8 ZN	MUTTER M12X1,25 D980 8 ZN	TUERCA M12X1,25 D980 8 ZN
15	F01410076R	ROS.M12 13X 24X2,5 U6592 ZN	WASHER 12 13X 24X2,5 U6592 ZN	RONDEL. M12 13X24X2,5 U6592 ZN	SCHEIBE M12 13X24X2,5 U6592 ZN	ARAND.M12 13X 24X2,5 U6592 ZN
16	F01010298R	VITE M12X1,25X80 U5740 8.8ZN	SCR. M12X1,25X80 U5740 8.8ZN	VIS M12X1,25X80 U5740 8.8 ZN	SCHR.M12X1,25X 80 U5740 8.8 ZN	TORN.M12X1,25X 80 U5740 8.8ZN
17	F01020468R	VITE M10X1,5X16 U5739 8.8ZN	SCR. M10X1,5X16 U5739 8.8ZN	RONDELLE M10X1,5 X 16	DUEBEL M10X1,5 X 16	TORNILLO M10X1,5X16 U5739 8
18	F01020432R	VITE M8X1,25X16 U5739 8.8ZN	SCR. M8X1,25X16 U5739 8.8ZN	VIS M8 X1,25X16 U5739 8.8 ZN	SCHRAUBE M8X1,25X16U5739 8.8ZN	TORNILLO M8X1,25X16 U5739 8.8
19	F01410064R	ROS.M10 10,5X 20X 2 U6592 ZN	WASHER M10 10,5X20X2 U6592 ZN	RONDEL. M10 10,5X20X2 U6592 ZN	SCHEIBE M10 10,5X20X2 U6592 ZN	ARAND.M10 10,5X 20X 2 U6592 ZN
20	G19002131R	PROTEZIONE P.D.P.	PDP GUARD			PROTECCI N.T.D.F.
21	F05150403R	CUFFIA PROTEZ.CARDANO X GRUPPO	POWER TAKE-OFF PROTECTION HOUS	PROTECTEUR PRISE DE PUISSANCE	SCHUTZKASTEN KRAFTABTRIEB	ENVOLTURA PROTECCI N T. DE P.
22	F01010295R	VITE M12X1,25X60 U5740 8.8ZN	SCR. M12X1,25X60 U5740 8.8ZN	VIS M12X1,25X60 U5740 8.8 ZN	SCHRA.M12X1,25X60 U5740 8.8 ZN	TORN. M12X1,25X60 U5740 8.8 ZN
23	F01200073R	DADO M12X1,25 U5587 CL8 ZN	NUT M12X1,25 U5587 6SZN	ECROU M12X1,25 U5587 6S ZN	MUTTER M12X1,25 U5587 6S ZN	TUERCA M12X1,25 U5587 6S ZN
24	F01010291R	VITE M12X1,25X40 U5740 8.8ZN	SCR. M12X1,25X40 U5740 8.8ZN	VIS M12X1,25X40 U5740 8.8 ZN	SCHR.M12X1,25X40 U5740 8.8 ZN	TORN. M12X1,25X40 U5740 8.8 ZN
25	F01500011R	ROS. 13 X35X5 D6340 C50 ZN	WASHER D. 12	RONDELLE D.12	SCHEIBE D.12	ARANDELA D.12
26	M14700512R	SUPPORTO	SUPPORT			
27	F01480123R	ROS.G 12,5X22,9X 4 FLZNNC-240H	WASHER M12 ZGP EXTRA P.	RONDELLE M12 ZGP EXTRA P.	UNTERLEGSCHIEBE M12 ZGP EXTRA	ARANDELA M12 ZGP EXTRA P.
28	F01020512R	VITE M12X1,75X35 U5739 8.8ZN	SCR. M12X1,75X35 U5739 8.8ZN	VIS M12X1,75X35 5739 8.8 ZN	SCHR. M12X1,75X35 5739 8.8 ZN	TORNILLO M12X1,75X35 U5739 8
29	F01010288R	VITE M12X1,25X35 U5740 8.8ZN	SCR. M12X1,25X35 U5740 8.8ZN	VIS M12X1,25X35 U5740 8.8 ZN	SCHR.M12X1,25X35 U5740 8.8 ZN	TORN.M12X1,25X35 U5740 8.8 ZN
30	M30400535R	SLITTA LATO TRASMISSIONE	TRANSMISSION SIDE SKID			
31	M30400536R	SLITTA LATO ESTERNO GF	SIDE PANEL SKID			
32	F01010283R	VITE M12X1,25X30 U5740 8.8ZN	SCR. M12X1,25X30 U5740 8.8ZN	VIS M 12X1,25X30	SCHRAUBE M 12X1,25X30	TORNILLO M 12X1,25X30

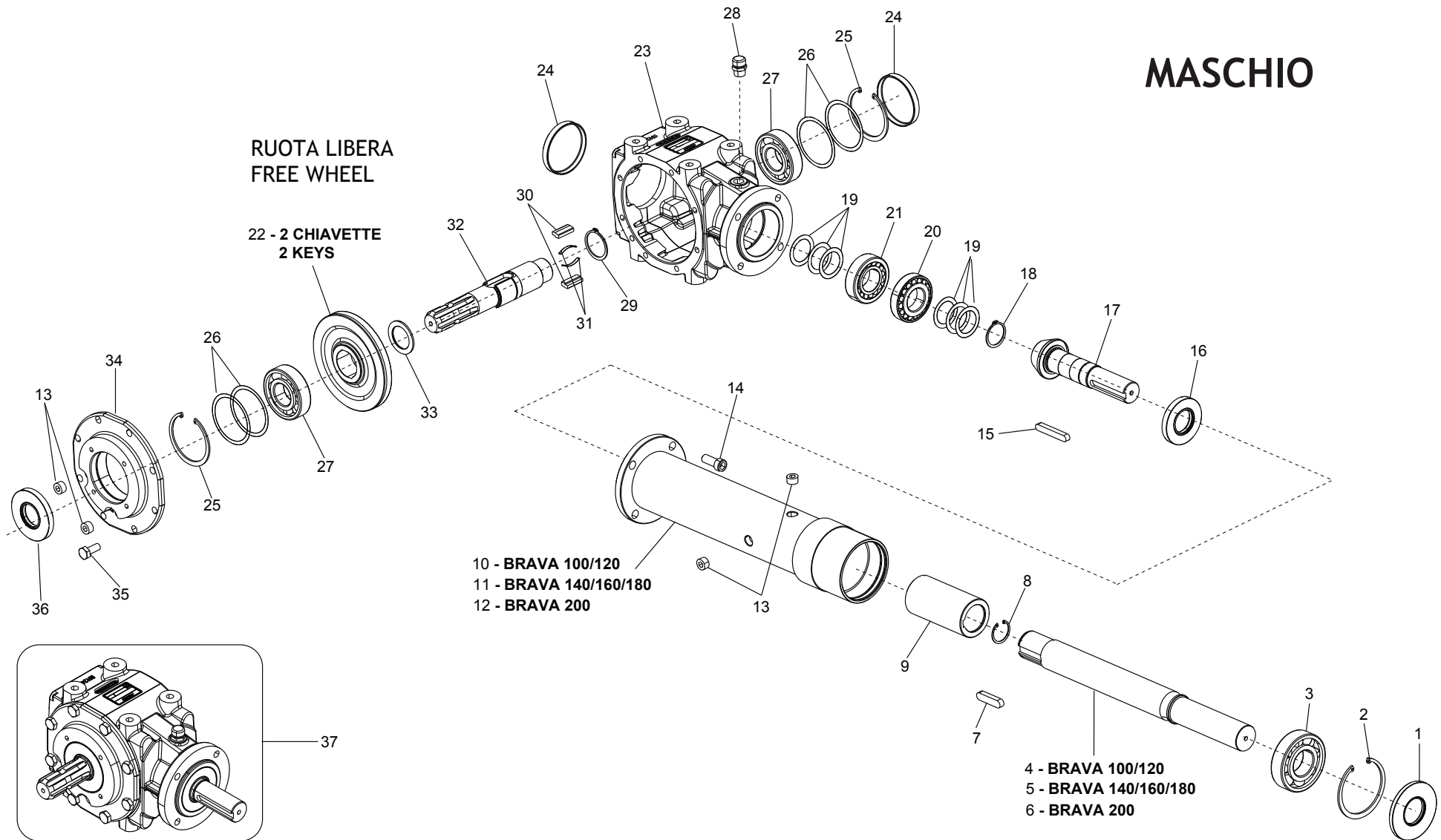

**ESPLOSO MOLTIPLICATORE MASCHIO
MASCHIO GEARBOX EXPLODED DRAWING**

TAV. 040

Pos.	Cod.	Descrizione	Description	Benennung	Description	Description
1	F03010280R	ANEL. T.AS 40X 90X 7 D3760NBR	RING T.AS 40X 90X 7 D3760 NBR	BAGUE T.AS 40X 90X 7 D3760 NBR	SCHUTZRING 40X90X7 D3760 NBR	ANILLO T.A 40X 90X 7 D3760 NBR
2	F02050447R	ANELLO E. DI 90X 3 U7437 C70	SEEGER RING DI 90X3 U7437 C70	BAGUE SEEGER DI 90X3 U7437 C70	SEEGERRING DI 90X 3 U7437 C70	ANILLO SEEGER DI 90X3 U7437
3	F04010218R	CUSC.D40 D90 B23 6308	BEARING D40 D90 B23 6308	ROULEMENT 6308	LAGER 6308	COJINETE 6308
4	T24121218R	ALBERO RINVIO D=45 L=157	SHAFT D=45 L=157	ARBRE D=45 L=157	ZENTRALWELLE D=45 L=157	ARBOL D=45 L=157
5	T24151218R	ALBERO RINVIO D=45 L=272	SHAFT D=45 L=272	ARBRE D=45 L=272	ZENTRALWELLE D=45 L=272	ARBOL D=45 L=272
6	T24191218R	ALBERO RINVIO D=45 L=437	SHAFT D=45 L=437	ARBRE D=45 L=437	ZENTRALWELLE D=45 L=437	ARBOL D=45 L=437
7	F02150132R	LINGUETTA 12X 8X 50 U6604A	PARALLEL KEY 12X8X50 U6604A	CLAVETTE 12X8X50	KEIL 12X8X50	LLAVE 12X8X50
8	F02050315R	ANELLO E. DI 34X 1,5 U7437 C70	SEEGER RING 34X1,5 U7437 C70	SEEGER E. 34X 1,5 U7437 C70	SEEGERING E. 34X 1,5 U7437 C70	ANILLO E. 34 X1,5 U7437 C70
9	T40000029R	0.312.7000.00 BOCCOLA COLLEGA	LINKAGE BUSHING			
10	T24121209R	DISTANZIALE TRASMISSIONE L=309	TRANSMISSION SPACER L=309	ENTRETOISE TRANSMISSION L=309	ANTRIEBSDISTANZSTUECK L=309	DISTANCIADOR TRASMISION L=309
11	T24151209R	DISTANZIALE TRASMISSIONE L=421	TRANSMISSION SPACER L=421	ENTRETOISE TRANSMISSION L=421	ANTRIEBSDISTANZSTUECK L=421	DISTANCIADOR TRASMISION L=421
12	T24191209R	DISTANZIALE TRASMISSIONE L=589	TRANSMISSION SPACER L=589	ENTRETOISE TRANSMISSION L=589	ANTRIEBSDISTANZSTUECK L=589	DISTANCIADOR TRASMISION L=589
13	M29100112R	TAPPO SCARICO OLIO	OIL OUTLET PLUG	BOUCHON DE VIDANGE HUILE	OELABLASSPFROPFEN	TAPON DESCARGADO ACEITE
14	F01040121R	VITE M10X1,5X35 U5931 8.8ZN	SCREW M10X1,5X35 U5931 8.8 ZN	VIS M10X1,5X35 U5931 8.8 ZN	SCHRAUB.M10X1,5X35 U5931 8.8ZN	TORN. M10X1,5X35 U5931 8.8ZN
15	F02150106R	LINGUETTA 10X 8X 65 U6604A	KEY 10X 8X 65 U6604A	CLAVETTE 10X 8X 65 U6604A	FEDER 10X 8X 65 U6604A	LLAVE 10X 8X 65 U6604A
16	F03010088R	ANELLO T.AS.35X 72X10 D3760NBR	OIL SEAL 35X72X10	PARA-HUILLE 35X72X10	OELABDICHTUNG 35X72X10	PARA-ACEITE 35X72X10
17	M07400003R	PIGNONE CONICO	BEVEL PINION	PIGNON CONIQUE	KEGELRITZEL	PINON CONICO
18	M07400004R	SEEGER 35X33X2.5	SEEGER RING 35X33X2.5	BAGUE SEEGER D 35X33X2,5	SEEGERRING D 35X33X2.5	ANILLO D 35X33X2,5
19	M07400002R	KIT SPESSORI 0,3 4 5	REINFORCEMENTS	RENFORTS	VERSTAERKERUNGEN	RENFUERZOS
20	F04050014R	CUSC.D35 D72 T18,25 30207	BEARING D35 D72 T18,25 30207	ROULEMENT 30207	LAGER 30207	COJINETE 30207
21	F04050070R	CUSC.D35 D72 T24,25 32207	BEARING D35 D72 T24,25 32207	ROULEMENT 32207	LAGER 32207	COJINETE 32207
22	M07400007R	0.311.6220.00 CORONA Z36 M4.35	RING BEVEL GEAR	COURONNE CONIQUE	KEGELRADKRANZ	CORONA CONICA
23	M03400020R	CORPO RIDUTTORE INT.	GEARBOX			
24	F03011026R	TAPPO CHIUSURA D=80 X 10 GA	COVER D. 80X10	BOUCHON 80X10	DECKEL 80X10	CORCHO 80X10
25	F02050425R	ANELLO E. DI 80X 2,5 U7437 C70	SEEGER RING D.80	BAGUE SEEGER D.80	SEEGERRING D.80	ANILLO E. DI 80X 2,5 U7437 C70
26	M07400006R	3 4 5.00 KIT SPESSORI	REINFORCEMENTS	RENFORTS	VERSTAERKERUNGEN	RENFUERZOS
27	F04010216R	CUSC.D35 D80 B21 6307	BEARING D35 D80 B21 6307	ROULEMENT 6307	LAGER 6307	COJINETE 6207
28	F03150718R	TAPPO 3 8 GAS CON SFIATO	GAS BREATHING PLUG 3 8	BOUCHON D HUILE SOUPIRAIL	OELENTLUEFTERSTOPFEN	TAPON ACEITE
29	M03400007R	ANELLO EL.SIC. X ALB 42 UNI743	SEEG.42X39,5X1,75.			
30	M07400005R	LINGUETTA	PARALLEL KEY	CLAVETTE	FEDER	LLAVE
31	M03400009R	MOLLA	SPRING	RESSORT	FEDER	MUELLE
32	M07400001R	0.311.3201.00 1 3 8 Z6 ALBERO	SHAFT	ARBRE	ZENTRALWELLE	ARBOL
33	M03400008R	SPESS. 48X35,3X1	0.259.7510.00 SHIMS 48X35,3X1			
34	T24001208R	FLANGIA CORPO TRASMISSIONE	GEARBOX COVER	COUVERCLE BOITE A VITESSES	GETRIEBEDECKEL	TAPA CAJA CAMBIO
35	F01020474R	VITE M10X1,5X25 U5739 8.8BR	SCR. M10X1,5X25 U5739 8.8BR	VIS M 10X25	SCHRAUBE M 10X25	TORNILLO M 10X25
36	F03010265R	ANELLO T.AS 35X 80X10 D3760NBR	RING T.AS 35X80X10 D3760 NBR	BAGUE T.AS 35X 80X10 D3760 NBR	SCHUTZRING 35X80X10 D3760 NBR	INEL T.AS 35X80X10 D3760 NBR
37	M07400201R	MOLTIPLICATORE COMER GIRAFFA	GEARBOX	BOITE DE VITESSE	WECHSELGETRIEBEGEAUESE	CAJA CAMBIO

BONDIOLI

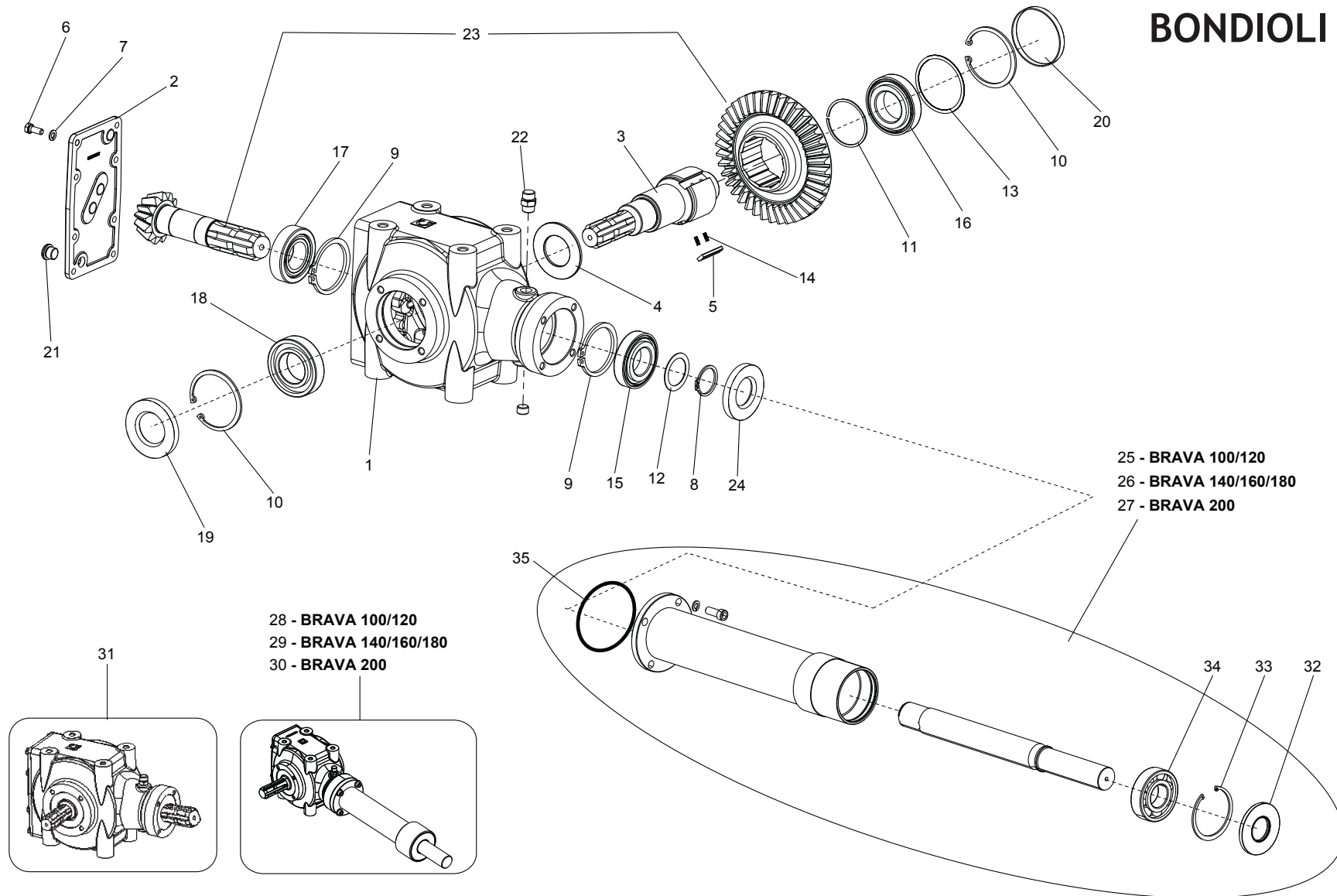

**ESPLOSO MOLTIPLICATORE BONDOLI
BONDOLI GEARBOX EXPLODED DRAWING**

TAV. 050

Pos.	Cod.	Descrizione	Description	Benennung	Description	Description
1	M30500151R	SCATOLA	GEARBOX	BOITE DE VITESSE	WECHSELGETRIEBEGEHAEUSE	CAJA CAMBIO
2	M30500108R	COPERCHIO	GEARBOX COVER	COUVERCLE BOITE A VITESSES	GETRIEBEBECKEL	TAPA CAJA CAMBIO
3	M30500152R	ALBERO	SHAFT	ARBRE	ZENTRALWELLE	ARBOL
4	M30500103R	DISTANZIALE	SPACER	ENTRETOISE	DISTANZSTUECK	DISTANCIADOR
5	M30500104R	PIASTRINA	PLATE	PLAQUETTE	PLATTE	PLAQUITA
6	F01020436R	VITE M8X1,25X20 U5739 8.8ZN	SCR. M8X1,25X20 U5739 8.8ZN	VIS M8X1,25X 20 U5739 8.8 ZN	SCHRAUBE M8X1,25X20U5739 8.8ZN	TORNILLO M8X1,25X20 U5739 8.8
7	F01480099R	ROS.G 8,4X14,4X2,7 FLZNNC-240H	GROWER WASHER D.8	RONDELLE GROWER D.8	SCHEIBE GROWER D.8	ARANDELA GROWER D.8
8	F02050147R	ANELLO E. DE 35X 2,5 U7436 C70	ELASTIC RING 35X2,5 U7436 C70	BAGUE ELASTIQUE 35X 2,5 U7436	RING 35X 2,5 U7436 C70	ANILLO 35X 2,5 U7436 C70
9	F02050403R	ANELLO E. DI 72X 2,5 U7437 C7	SEEGER RING E.72X2,5 U7437 C70	SEEGER E. 72X 2,5 U7437 C70	SEEGERING E. 72X 2,5 U7437 C70	ANILLO E. DI 72X 2,5 U7437 C7
10	F02050425R	ANELLO E. DI 80X 2,5 U7437 C70	SEEGER RING D.80	BAGUE SEEGER D.80	SEEGERRING D.80	ANILLO E. DI 80X 2,5 U7437 C70
11	M30500109R	ANELLO E. D.50 M3200	ELASTIC RING D.50	BAGUE ELASTIQUE D.50	RING D.50	ANILLO D.50
12	M30500105R	KIT SPESSORI	REINFORCEMENTS	RENFORTS	VERSTAERKERUNGEN	RENFUERZOS
13	M30500106R	KIT SPESSORI	REINFORCEMENTS	RENFORTS	VERSTAERKERUNGEN	RENFUERZOS
14	M50400905R	MOLLA PER RUOTA LIBERA	SPRING FOR FREE WHEEL			
15	F04010175R	CUSC.D35 D72 B17 6207	BEARING D35 D72 B17 6207	ROULEMENT 6207	LAGER 6207	COJINETE 6207
16	F04010180R	CUSC.D40 D80 B18 6208	BEARING D40 D80 B18 6208	ROULEMENT 6208	LAGER 6208	COJINETE 6208
17	F04050014R	CUSC.D35 D72 T18,25 30207	BEARING D35 D72 T18,25 30207	ROULEMENT 30207	LAGER 30207	COJINETE 30207
18	F04050017R	CUSC.D40 D80 T19,75 30208	BEARING D40 D80 T19,75 30208	ROULEMENT D40 D80 T19,75 302	LAGER D40 D80 T19,75	COJINETE D40 D80 T19,75 3020
19	F03010277R	ANELLO T.AS 40X 80X10 D3760NBR	OIL SEAL 40X80X10 NBR	BOURAGE 40X80X10 NBR	OELABDICHTUNG 40X80X10 NBR	ANILLO T.AS 40X 80X10 D3760NBR
20	F03011026R	TAPPO CHIUSURA D=80 X 10 GA	COVER D. 80X10	BOUCHON 80X10	DECKEL 80X10	CORCHO 80X10
21	F03150719R	TAPPO 3 8 GAS	GAS CAP 3 8	BOUCHON	DECKEL	CORCHO
22	F03150606R	TAPPO SFIATO 1 4 GAS POT58	OIL BREATHING PLUG 1 4 GAS	BOUCHON REFOUL. GAZ POT58	ENTLSFTUNGSPFROPFEN 1 4 GAS PO	TAP N PURGADOR 1 4 GAS POT58
23	M30500153R	COPPIA CONICA	BEVEL GEAR PAIR	COUPLE CONIQUE	KEGELRITZELSATZ	PAR CONICO
24	F03010265R	ANELLO T.AS 35X 80X10 D3760NBR	RING T.AS 35X80X10 D3760 NBR	BAGUE T.AS 35X 80X10 D3760 NBR	SCHUTZRING 35X80X10 D3760 NBR	INEL T.AS 35X80X10 D3760 NBR
25	M28412102R	PROLUNGA ALBERO TRASMISSIONE	TRANS. SHAFT EXTENSION	RALLONGE ARBRE DE TRANSMISS.	VERLZNGERUNG ANTRIEBSWELLE	EXTENSION ARBOL TRANS.
26	M28415102R	PROLUNGA ALBERO TRASMISSIONE	TRANS. SHAFT EXTENSION	RALLONGE ARBRE DE TRANSMISS.	VERLZNGERUNG ANTRIEBSWELLE	EXTENSION ARBOL TRANS.
27	M28419102R	PROLUNGA ALBERO TRASMISSIONE	TRANS. SHAFT EXTENSION	RALLONGE ARBRE DE TRANSMISS.	VERLZNGERUNG ANTRIEBSWELLE	EXTENSION ARBOL TRANS.
28	M28412202R	CORPO MOLT.540 RPM L=500	GEARBOX 540 RPM L=500			
29	M28415202R	CORPO MOLT.540 RPM L=616	COMPL.GEARBOX L=616	BOITE DE VITESSE COMPL.L=616	WECHSELGETRIEBE KOMPL.L=616	CAJA CAMBIO COMPLETA L=616
30	M28419202R	CORPO MOLT.540 RPM L=780	COMPL.GEARBOX L=780	BOITE DE VITESSE COMPL.L=780	WECHSELGETRIEBE KOMPL.L=780	CAJA CAMBIO COMPLETA L=780
31	M28400101R	SCATOLA MOLTIPL.540 BONDOLI	GEARBOX	BOITE DE VITESSE	WECHSELGETRIEBEGEHAEUSE	CAJA CAMBIO
32	M30500160R	ANELLO T. 40X90X10	OIL SEAL 40X90X10	PARE-HUILE 40X90X10	OELABDICHTUNG 40X90X10	PARA-ACEITE 40X90X10
33	F02050447R	ANELLO E. DI 90X 3 U7437 C70	SEEGER RING DI 90X3 U7437 C70	BAGUE SEEGER DI 90X3 U7437 C70	SEEGERRING DI 90X 3 U7437 C70	ANILLO SEEGER DI 90X3 U7437
34	F04010218R	CUSC.D40 D90 B23 6308	BEARING D40 D90 B23 6308	ROULEMENT 6308	LAGER 6308	COJINETE 6308
35	M30500161R	ANELLO OR 72.69X2.62	GASKET OR 72.69X2.62	BAGUE OR 72.69X2.62	RING OR 72.69X2.62	ANILLO OR 72.69X2.62

TAV. 060

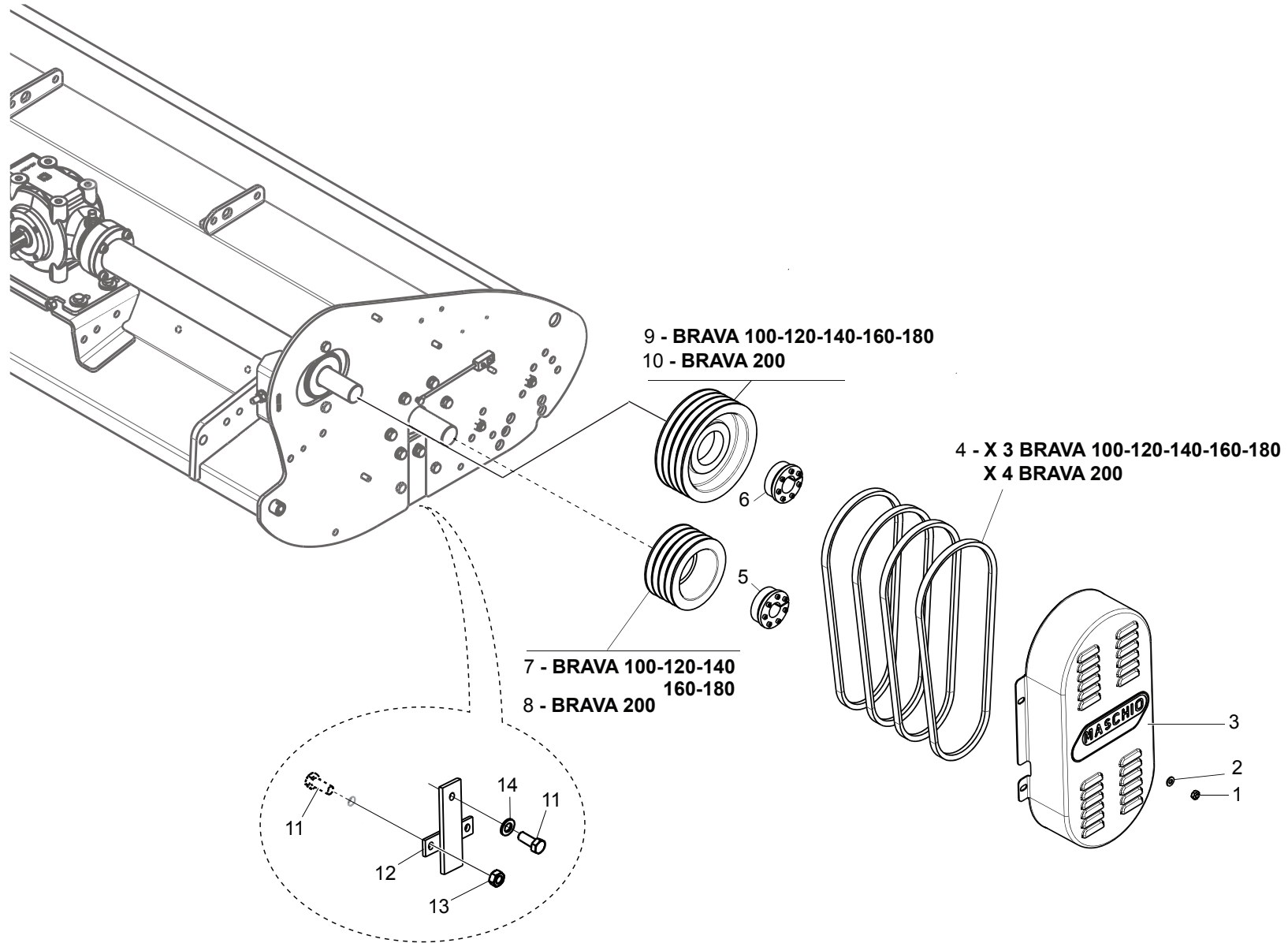

**TRASMISSIONE LATERALE
SIDE TRANSMISSION**

TAV. 060

Pos.	Cod.	Descrizione	Description	Benennung	Description	Description
1	F01220034R	DADO M10X1,25 D980 8ZN	NUT M10X1,25 D980 8ZN	ECRO.M10X1,25 D980 8 ZB	MUTT.M10X1,25 D980 8 ZB	TUER.M10X1,25 D980 8 ZB
2	F01410064R	ROS.M10 10,5X 20X 2 U6592 ZN	WASHER M10 10,5X20X2 U6592 ZN	RONDEL. M10 10,5X20X2 U6592 ZN	SCHEIBE M10 10,5X20X2 U6592 ZN	ARAND.M10 10,5X 20X 2 U6592 ZN
3	T16003150R	COMP.CARTER	COMPLETE CARTER			
4	F06010039R	CINGHIA SPBX L=1320	BELT SPBX L=1320	COURROIE L=1320	SCHAUBE SPBX L=1320	CORREA SPBX L=1320
5	F06060038R	CALETTATORE AUTOCENTR.40X80	SELF CENTR.CLAMP.EL.40X80			
6	F06060039R	CALETTATORE AUTOCENTR.45X80	SELF CENTR.CLAMP.EL.45X80	EMBOITEMENT AUTOBLOCANT 45X80		
7	T22003001R	PULEGGIA ROTORE DP=160	DRIVING PULLEY	POULIE TIRANTE	ZIEHEN RIEMEN	ROLDANA DE TIRAR
8	T16003005R	PULEGGIA DP=160 A 4 GOLE	PULLEY	POULIE	SCHEIBE	ROLDANA
9	T16003002R	PULEGGIA SPB MOTRICE D=225 3V	DRIVING PULLEY	POULIE TIRANTE	ZIEHEN RIEMEN	ROLDANA DE TIRAR
10	T30003002R	PULEGGIA ROTORE D=224 4V	DRIVING PULLEY	POULIE TIRANTE	ZIEHEN RIEMEN	ROLDANA DE TIRAR
11	F01010283R	VITE M12X1,25X30 U5740 8.8ZN	SCR. M12X1,25X30 U5740 8.8ZN	VIS M 12X1,25X30	SCHRAUBE M 12X1,25X30	TORNILLO M 12X1,25X30
12	T24005110R	CHIUSURA LATERALE	REAR LATERAL PANEL	CAPOT ARRIERE LATERAL	HINTERE BLECH	PLANCHA LATERALE
13	F01220047R	DADO M12X1,25 D980 8ZN	NUT M12X1,25 D980 8ZN	ECROU M12X1,25 D980 8 ZN	MUTTER M12X1,25 D980 8 ZN	TUERCA M12X1,25 D980 8 ZN
14	F01480123R	ROS.G 12,5X22,9X 4 FLZNNC-240H	WASHER M12 ZGP EXTRA P.	RONDELLE M12 ZGP EXTRA P.	UNTERLEGSCHIEBE M12 ZGP EXTRA	ARANDELA M12 ZGP EXTRA P.

TAV. 070

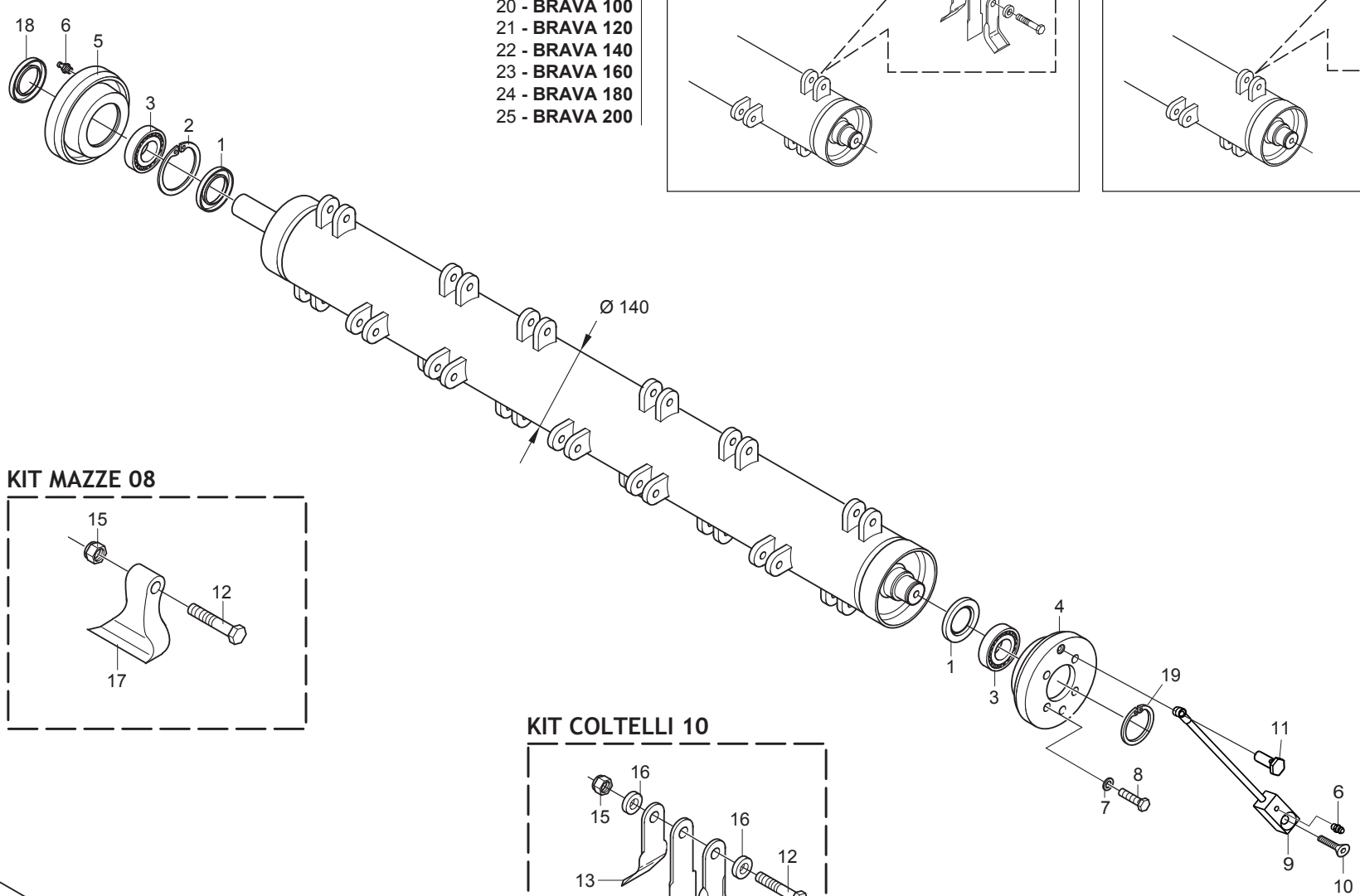

- 20 - BRAVA 100
- 21 - BRAVA 120
- 22 - BRAVA 140
- 23 - BRAVA 160
- 24 - BRAVA 180
- 25 - BRAVA 200

- 26 - BRAVA 100
- 27 - BRAVA 120
- 28 - BRAVA 140
- 29 - BRAVA 160
- 30 - BRAVA 180
- 31 - BRAVA 200

KIT MAZZE 08

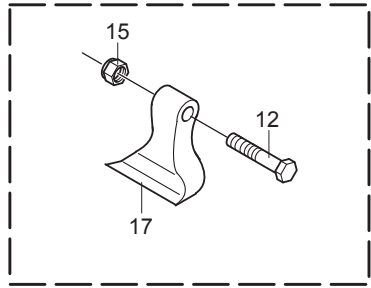

KIT COLTELLI 10

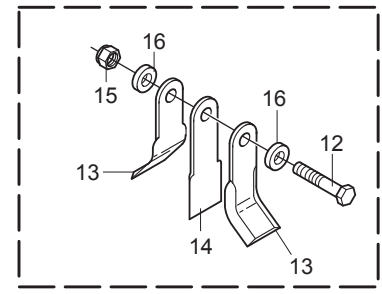

**ROTORE ED UTENSILI
ROTOR AND BLADES**

TAV. 070

Pos.	Cod.	Descrizione	Description	Benennung	Description	Description
1	F03010218R	ANELLO T.A. 65X100X10 D3760NBR	OIL SEAL 65X100X10	PARE-HUILE 65X100X10 D3760NBR	OELABDICHTUNG 65X100X10 D3760	ANILLO 65X100X10
2	F02050471R	ANELLO E. DH100X 3 U7437 C70	SEEGER RING D.100	BAGUE SEEGER D.100	SEEGERRING D.100	ANILLO SEEGER D.100
3	F04010031R	CUSC.D45 D100 B25 21309	BEARING D45 D100 B25 21309	ROULEMENT D45 D100 B25	LAGER D45 D100 B25	COJINETE D45 D100 B25
4	M25400410R	SUPPORTO ROTORE LATO TRASMISS.	ROTOR SUPPORT TRANSM. SIDE	SUPPORT ROTOR COTE TRANSM.	ROTORHALTER TRANSMISSIONSEITE	SOPORTE ROTOR LADO TRASMISSION
5	M25400409R	SUPPORTO ROTORE LATO ESTERNO	ROTOR SUPPORT SIDE PANEL	SUPPORT ROTOR PARTIE LATERALE	ROTORHALTER SEITENWAND	SOPORTE ROTOR FLANCO
6	F01100011R	ING.M 6X1 7663-A 9SMNPB28 ZN	GREASE NIPPLE M6X1 7663-A ZN	GRAISS. A BILLE M6X1 7663A ZN	SCHMIERBUECHE M6X1 7663-A ZN	ENG.M 6X1 7663-A 9SMNPB28 ZN
7	F01480123R	ROS.G 12,5X22,9X 4 FLZNNC-240H	WASHER M12 ZGP EXTRA P.	RONDELLE M12 ZGP EXTRA P.	UNTERLEGSSCHEIBE M12 ZGP EXTRA	ARANDELA M12 ZGP EXTRA P.
8	F01010283R	VITE M12X1,25X30 U5740 8.8ZN	SCR. M12X1,25X30 U5740 8.8ZN	VIS M 12X1,25X30	SCHRAUBE M 12X1,25X30	TORNILLO M 12X1,25X30
9	T24004000R	ASSIEME INGRASSATORE	GREASE NIPPLE	GRAISSEUR	SCHMIERNIPPEL	ENGRASADOR
10	F01030058R	VITE M8X1,25X30 U5933 10.9ZD	SCR. M8X1,25X30 U5933 10.9ZD	VIS M8 X1,25 X30 U5933 10,9 ZD	SCHRAUBE M8X1,25X30 U5933 10,9	TORNILLO M8X1,25X30 U5933 10,9
11	T24004003R	VITE FORATA PER INGRASSAGGIO	BOLT	VIS	SCHRAUBE	TORNILLO
12	F20110093R	VIT. M16X1.5X95 SPEC. BR.10.9	BOLT M16X1.5X95 SPEC. BR.10.9	VIS M16X1.5X95 BR	SCHRAUBE M16X1.5X95 SPEC.	TORNILLO M16X1.5X95 SPEC.
13	T21004040R	COLTELLO A Y L=130	BLADE Y L=130	COUTEAU Y L=130	MESSER Y L=130	CUCHILLO A Y L=130
14	T21004050R	COLTELLO DIRITTO INT.L=130	STRAIGHT BLADE L=130	COUTEAU INT. L=130	INNEN MESSER L=130	CUCHILLO INT. L=130
15	F01230084R	DADO M16X1,5 D982 6ZN	NUT M16X1,5 D982 6ZN	ECROU AUTOBL.M16X1,5 ZN	SELBSTSPERR.MUTTER M16X1,5	DADO AUTOBL. M16X1,5
16	T21004045R	DISTANZIALE COLTELLI ZPG	BLADE SPACER	ENTRTOISE COTEAU	MESSER DISTANZSTUECK	DISTANCIADOR CUCHILLO
17	T24004025R	MAZZA 08	HAMMER 08	MARTEAUX 08 IMPR. 130	SCHLEGEL 08	CUCHILLAS 08
18	F03010139R	ANELLO T.A. 45X 80X10 D3760NBR	OIL SEAL 45X 80X10 D3760NBR	BOURRAGE 45X 80X10 D3760NBR	OELABDICHTUNG 45X 80X10 D3760	JUNTA DE ACEITE 45X 80X10
19	F02050191R	ANELLO E. DE 45X1,75 U7435 C70	RING 45X1,75 U7435 C70	BAGUE ELASTIQUE UNI 7435	EXT.RING DE 45X1,75 U7435 C70	ANILLO DE 45X1,75 U7435 C70
20	M25410412R	ROT.VITA-BRAVA 120 C10 RICAMBI	ROT.VITA-BRAVA 120 C10			
21	M25412412R	ROT.VITA-BRAVA 120 C10 RICAMBI	ROT.VITA-BRAVA 120 C10			
22	M25413412R	ROTORE COLT. 10	ROTOR WITH BLADES 10	ROTOR COUTEAUX 10	LAEUFER MESSER 10	ROTOR CUCHILLOS 10
23	M25415412R	ROTORE COLT. 10	ROTOR WITH BLADES 10	ROTOR COUTEAUX 10	LAEUFER MESSER 10	ROTOR CUCHILLOS 10
24	M25417412R	ROTORE COLT. 10	ROTOR WITH BLADES 10	ROTOR COUTEAUX 10	LAEUFER MESSER 10	ROTOR CUCHILLOS 10
25	M25419412R	ROTORE COLT. 10	ROTOR WITH BLADES 10	ROTOR COUTEAUX 10	LAEUFER MESSER 10	ROTOR CUCHILLOS 10
26	M25410411R	ROTORE VITA-BRAVA100 M08 RICAM	ROTOR HAM.08 VITA-BRAVA			
27	M25412411R	ROTORE VITA-BRAVA120 M08 RICAM	ROTOR HAM.08 VITA-BRAVA	ROTOR HAM.08 VITA-BRAVA		
28	M25413411R	ROTORE MAZZE 08	ROTOR HAMMER 08	ROTOR MARTEAUX 08	LAEUFER SCHLEGEL 08	ROTOR MARTILLOS 08
29	M25415411R	ROTORE MAZZE 08	ROTOR HAMMER 08	ROTOR MARTEAUX 08	LAEUFER SCHLEGEL 08	ROTOR MARTILLOS 08
30	M25417411R	ROTORE MAZZE 08	ROTOR HAMMER 08	ROTOR MARTEAUX 08	LAEUFER SCHLEGEL 08	ROTOR MARTILLOS 08
31	M25419411R	ROTORE MAZZE 08	ROTOR HAMMER 08	ROTOR MARTEAUX 08	LAEUFER SCHLEGEL 08	ROTOR MARTILLOS 08

TAV. 080

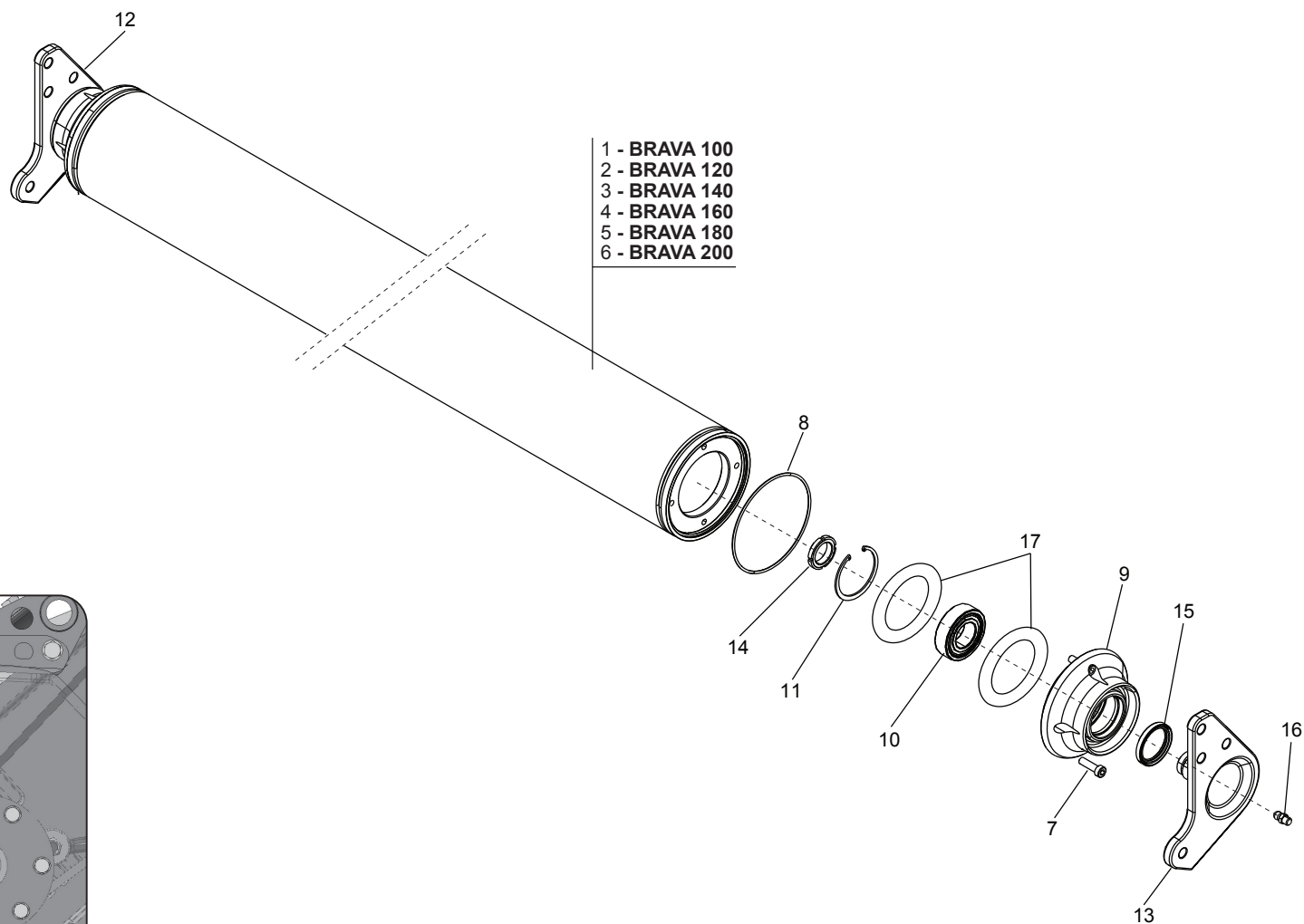

**RULLO POSTERIORE
REAR ROLLER**

TAV. 080

Pos.	Cod.	Descrizione	Description	Benennung	Description	Descripcion
1	M30410602R	RULLO POST.D=168,3 L=820	REAR ROLLER D=168,3 L=820			
2	M30412602R	RULLO POST.D=168,3 L=1020	REAR ROLLER D=168,3 L=1020			
3	M30414602R	RULLO POST.D=168,3 L=1220	REAR ROLLER D=168,3 L=1220			
4	M30415602R	RULLO POST.D=168,3 L=1410	REAR ROLLER D=168,3 L=1410			
5	M30417602R	RULLO POST.D=168,3 L=1560	REAR ROLLER D=168,3 L=1560			
6	M30419602R	RULLO POST.D=168,3 L=1760 -	REAR ROLLER D=168,3 L=1760 -			
7	F01030285R	VITE M10X1.25X35 U5931 8.8DLS	SCREW M10X1.25X35 DLS			
8	F03010758R	ANEL. OR 148,82X3,53 NBR 70	GASKET OR 148,82X3,53 NBR 70	BAGUE OR 148,82X3,53 NBR 70	RING OR 148,82X3,53 NBR 70	ANILLO OR 148,82X3,53 NBR 70
9	M30400607R	SUPPORTO CUSCINETTO RULLO	ROLLER BEARING SUPPORT			
10	F04010327R	CUSC.D40 D80 B23 62208 2RS1	BEARING D40 D80 B23 62208 2RS1		BEARING D40 D80 B23 62208 2RS2	
11	F02050425R	ANELLO E. DI 80X 2,5 U7437 C70	SEEGER RING D.80	BAGUE SEEGER D.80	SEEGERRING D.80	ANILLO E. DI 80X 2,5 U7437 C70
12	M30400631R	STAFFA RULLO SX	LEFT STIRRUP			
13	M30400630R	STAFFA RULLO DX	RIGHT STIRRUP			
14	F02010022R	GHIERA AU.GUK M35X1,5 T.4H ZN	SELF LOCKING NUT M35X1,5	COLLIER AUTOBL. M35X1,5	SELBSTSP. NUTMUTTER M35X1,5	VIROLA AUTOBL. M35X1,5
15	F03010160R	ANELLO T.A. 50X 65X 8 D3760NBR	OIL SEAL 50X65X8	PARE-HUILE 50X65X8	OELABDICHTUNG 50X65X8	PARA-ACEITE 50X65X8
16	F01100011R	ING.M 6X1 7663-A 9SMNPB28 ZN	GREASE NIPPLE M6X1 7663-A ZN	GRAISS. A BILLE M6X1 7663A ZN	SCHMIERBUECHE M6X1 7663-A ZN	ENG.M 6X1 7663-A 9SMNPB28 ZN
17	M30400617R	ROSETTA SPES. D=80 D=42 0,5	WASHER SPACER D=80 D=42 0,5			

TAV. 090

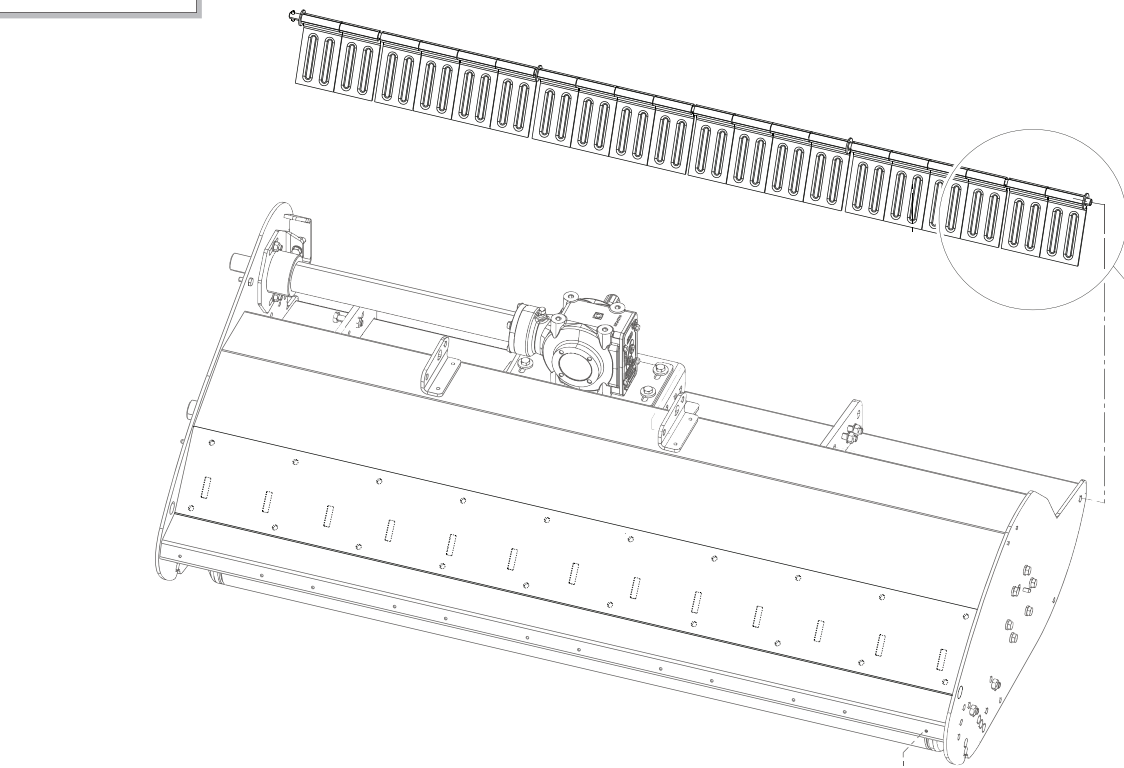

- 1 - BRAVA 100
- 2 - BRAVA 120
- 3 - BRAVA 140
- 4 - BRAVA 160
- 5 - BRAVA 180
- 6 - BRAVA 200

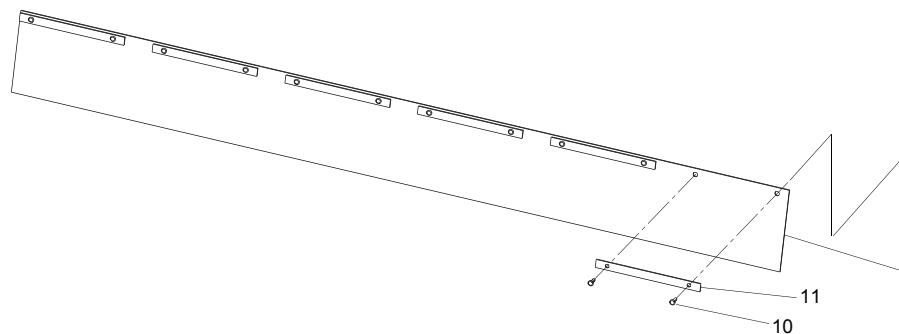
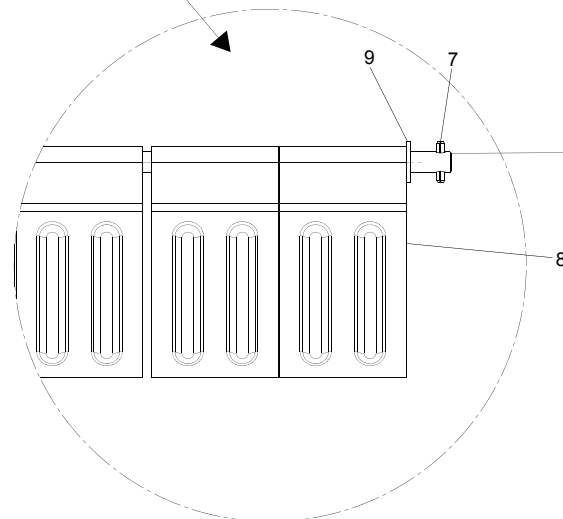

- 12 - BRAVA 100
- 13 - BRAVA 120
- 14 - BRAVA 140
- 15 - BRAVA 160
- 16 - BRAVA 180
- 17 - BRAVA 200

**PROTEZIONI DI SICUREZZA
PROTECTIONS**

TAV. 090

Pos.	Cod.	Descrizione	Description	Benennung	Description	Description
1	T21095016R	ASTA PER BANDELLE	PIN	GOUJON	BOLZEN	PERNO
2	T21115016R	ASTA PER BANDELLE	PIN	GOUJON	BOLZEN	PERNO
3	T21135016R	ASTA PER BANDELLE	PIN	GOUJON	BOLZEN	PERNO
4	T24155085R	ASTA BANDELLE CR 155	PROTECTION FLAP BAR CR155	TIGE PALETTE PROTECTION CR155	DAS TURBAND STANGE CR155	VARILLA BANDA CR155
5	T24175085R	ASTA BANDELLE CR 170	PROTECTION FLAP BAR CR170	TIGE PALETTE PROTECTION CR170	DAS TURBAND STANGE CR170	VARILLA BANDA CR170
6	T24195085R	ASTA BANDELLE CR 190	PROTECTION FLAP BAR CR190	TIGE PALETTE PROTECTION CR190	DAS TURBAND STANGE CR190	VARILLA BANDA CR190
7	F02100114R	SPINA E.P. 6X 30 U6873 C70 BR	ELASTIC PIN 6X30	GOUJON ELASTIQUE 6X30	SPANNHUELSE 6X30	ESPINA ELASTICA 6X30
8	M24400518R	BANDELLA PROTEZ. 93X170 ZG	PROTECTION BAR	BANDE PROTECTION	SCHUTZWORNE	ALETA PROTECCION
9	F01410100R	ROS.M16 17X 30X 3 U6592 ZN	WASHER M16 17X30X3 U6592 ZN	RONDELLE M16 17X30X3 ZN	SCHRAUBE M16 17X 30X3 U6592 ZN	ARAND.M16 17X 30X 3 U6592 ZN
10	F02250160R	RIVETTO STR. 6,4X22 ACCIAIO	RIVET	RIVET	KUPFERNIET	REMACHE
11	M07400953R	PIATTO PER ATTACCO GOMMA	PLATE	PLAT	PLATTE	PLATO
12	M33410544R	PROTEZ.POSTER. BARBI 100 07	REAR GUARD BARBI 100 07			
13	M33412544R	PROTEZ.POSTER.120	REAR PROTECTION 120	PROTECTION ARRIERE 120	HINTERER SCHUTZ 120	PROTECCION TRASERA 120
14	M33414544R	PROTEZ.POSTER.140	REAR PROTECTION 140	PROTECTION ARRIERE 140	HINTERER SCHUTZ 140	PROTECCION TRASERA 140
15	T24155681R	PROTEZ. POSTERIORE PVC L=1530	REAR GUARD PVC L=1530			
16	T24175681R	PROTEZ. POSTERIORE PVC L=1680	REAR GUARD PVC L=1681			
17	T24195681R	PROTEZ. POSTERIORE PVC L=1880	REAR GUARD PVC L=1880			

OPTIONAL

10 - BRAVA 140
11 - BRAVA 160-180-200

1 - BRAVA 140
9 - BRAVA 160-180-200-230L-250L

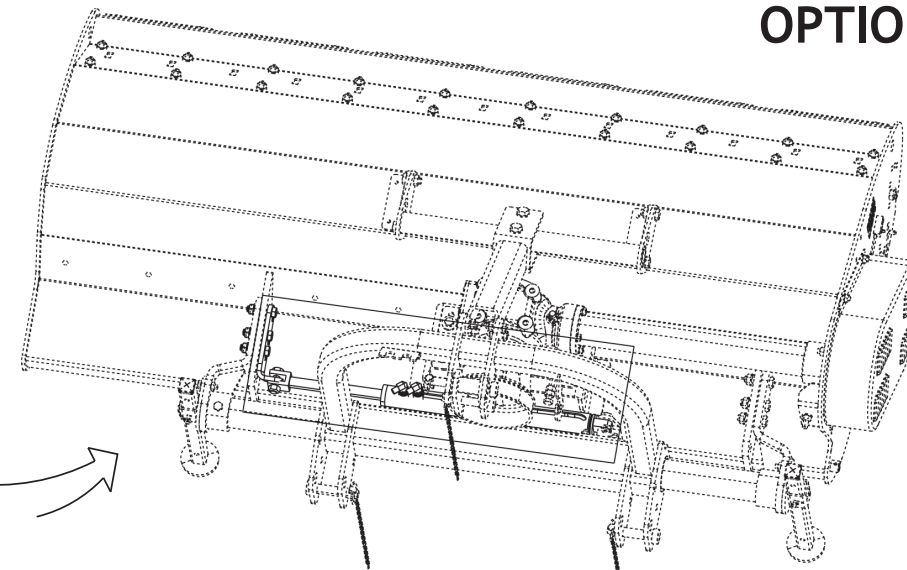
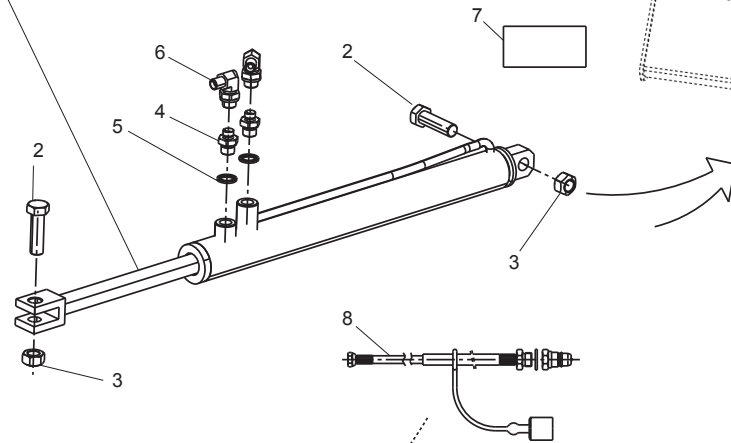

RIMUOVERE
REMOVE

SPOSTARE
SHIFT

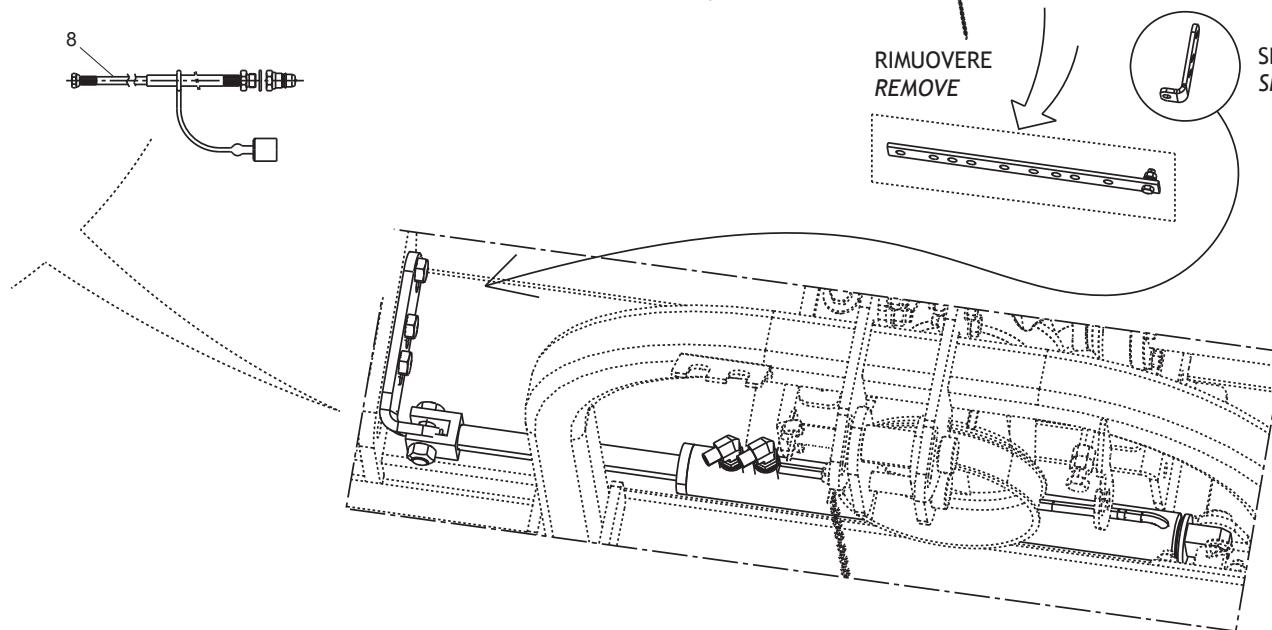

**KIT SPOSTAMENTO IDRAULICO
HYDRAULIC OFFSET ADJUSTER KIT**

TAV. 100

Pos.	Cod.	Descrizione	Description	Benennung	Description	Description
1	M33412549R	MARTINETTO IDRAUL. BARBI 120	HYDRAULIQUE ADJUSTER	MANIVELLE HYDRAULIQUE	HYDRAUL.SPINDELVERSTELLUNG	GATO HYDRAULICO
2	F01010115R	VITE M16X1,5X55 U5738 8.8ZN	SCR. M16X1,5X55 U5738 8.8ZN	VIS M16X1,5 X55 U5738 8.8ZN	SCHRAU. M16X1,5X55 U5738 8.8ZN	TORN. M16X1,5X55 U5738 8,8ZN
3	F01220070R	DADO M16X1,5 D980 10ZN	NUT M16X1,5 D980 8ZN	ECRO.M16X1,5 D980 8ZN	MUTTER M16X1,5 D980 8ZN	TUER.M16X1,5 D980 8ZN
4	F03150310R	NIPPLO MM CIL-CIL 3 8-1 4 ZN	NIPPLE CYL.MALE3 8-1 4 ZN	NIPPLE MALE CYL.3 8-1 4 ZN	NIPPELZYL.3 8-1 4 ZN	NIPLE MACHO CIL.3 8-1 4 ZN
5	F03020070R	RONDELLA BONDED AUTOCENT 3 8	AUTOCENT BONDED WASHER 3 8	RONDELLE BONDED AUTOCENT 3 8	SCHEIBE BONDED AUTOCENT 3 8	ARANDELA BONDED AUTOCENT 3 8
6	F03150842R	ADATT.A 90 ORIENT.3 8-1 4	90 ADAPTOR 3 8-1 4	ADAPTEUR 90	PASSTUECK 90	ADAPTADOR 90
7	F20030081R	ETICH.SCOPIO TUBI	DECAL.HOSE BURST	ETIQUETTE	AUFKLEBER	ETIQUETA
8	M70100568R	COMP. TUBAZIONE IDR. L=2800	HYDRAULIC TUBE	TUBE HYDRAUL.	HYDRAUL. ROHR	TUBO HYDRAULICO
9	M33416549R	MARTINETTO IDRAUL.BARBI140-180	HYDRAULIQUE ADJUSTER	MANIVELLE HYDRAULIQUE	HYDRAUL.SPINDELVERSTELLUNG	GATO HYDRAULICO
10	F03100156R	SERIE GUARN.X CIL. M33412549	GASKET SET	SERIE JOINTS	DICHTUNGSSATZ	SERIE JUNTAS
11	F03100157R	SERIE GUARN.X CIL. M33416549	GASKET SET	SERIE JOINTS	DICHTUNGSSATZ	SERIE JUNTAS

TAV. 110

LAMIERA ANTIUSURA DOUBLE SKIN

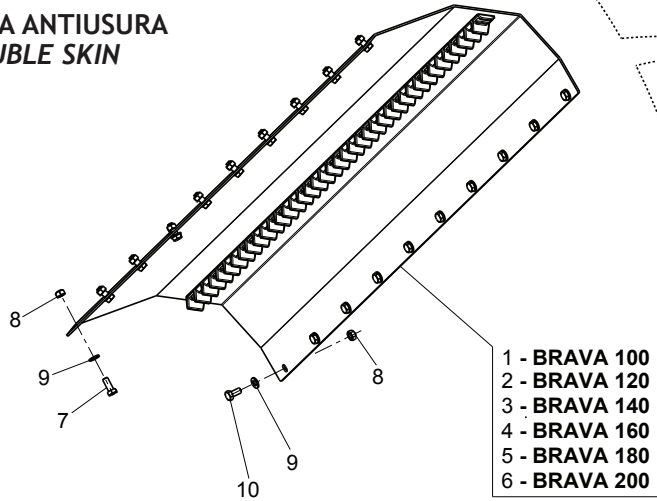

- 1 - BRAVA 100
- 2 - BRAVA 120
- 3 - BRAVA 140
- 4 - BRAVA 160
- 5 - BRAVA 180
- 6 - BRAVA 200

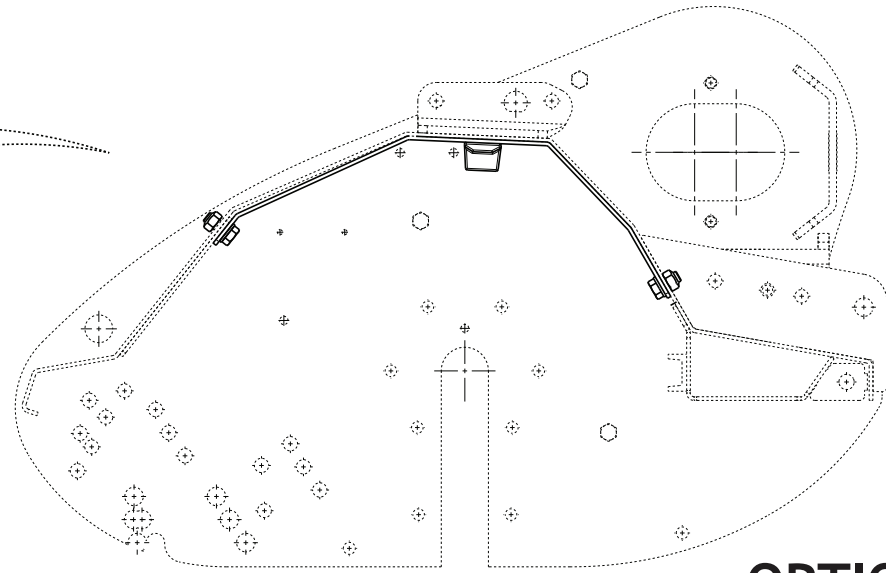

OPTIONAL

DENTI DI RACCOLTA COLLECTING RAKES

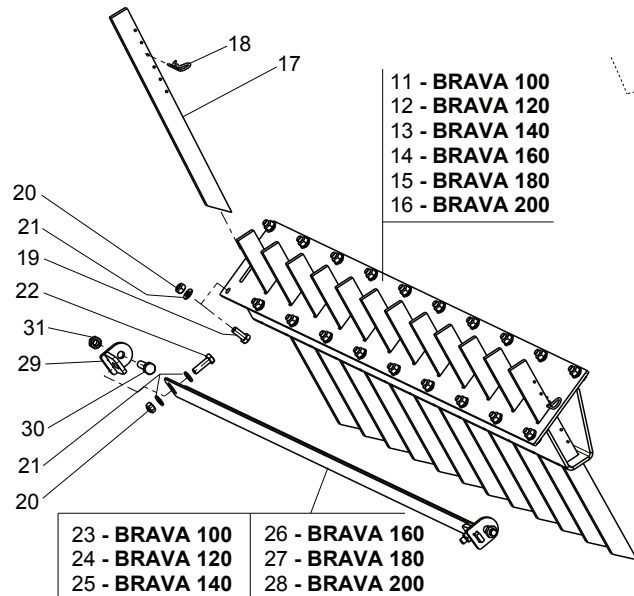

- 11 - BRAVA 100
- 12 - BRAVA 120
- 13 - BRAVA 140
- 14 - BRAVA 160
- 15 - BRAVA 180
- 16 - BRAVA 200

- 23 - BRAVA 100
- 24 - BRAVA 120
- 25 - BRAVA 140
- 26 - BRAVA 160
- 27 - BRAVA 180
- 28 - BRAVA 200

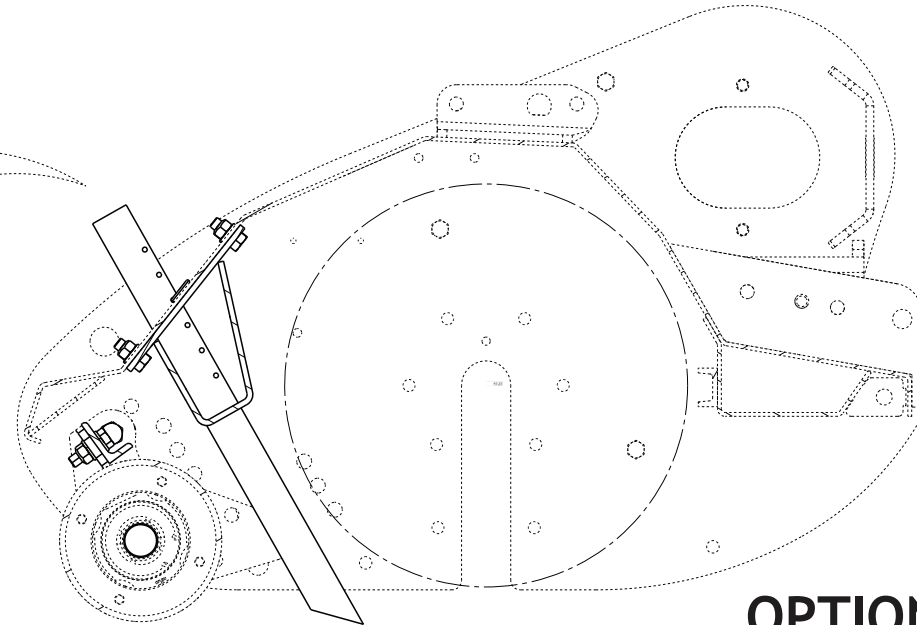

OPTIONAL

**LAMIERA ANTIUSURA E DENTI DI RACCOLTA (OPT.)
DOUBLE SKIN AND COLLECTING RAKES (OPTIONAL KITS)**

TAV. 110

Pos.	Cod.	Descrizione	Description	Benennung	Description	Description
1	M14710548R	COMPOSTO LAMIERA ANTIUSURA	DOUBLE SKIN FRAME ASSEMBLY			
2	M14712548R	COMPOSTO LAMIERA ANTIUSURA	DOUBLE SKIN FRAME			
3	M14714548R	COMPOSTO LAMIERA ANTIUSURA	DOUBLE SKIN FRAME ASSEMBLY			
4	M14716548R	COMPOSTO LAMIERA ANTIUSURA	DOUBLE SKIN FRAME ASSEMBLY			
5	M14718548R	COMPOSTO LAMIERA ANTIUSURA	DOUBLE SKIN FRAME ASS.			
6	M14720548R	COMPOSTO LAMIERA ANTIUSURA	WEAR PLATE			
7	F01010283R	VITE M12X1,25X30 U5740 8.8ZN	SCR. M12X1,25X30 U5740 8.8ZN	VIS M 12X1,25X30	SCHRAUBE M 12X1,25X30	TORNILLO M 12X1,25X30
8	F01220047R	DADO M12X1,25 D980 8ZN	NUT M12X1,25 D980 8ZN	ECROU M12X1,25 D980 8 ZN	MUTTER M12X1,25 D980 8 ZN	TUERCA M12X1,25 D980 8 ZN
9	F01410076R	ROS.M12 13X 24X2,5 U6592 ZN	WASHER 12 13X 24X2,5 U6592 ZN	RONDEL. M12 13X24X2,5 U6592 ZN	SCHEIBE M12 13X24X2,5 U6592 ZN	ARAND.M12 13X 24X2,5 U6592 ZN
10	M71100532R	VITE M12X1,25X 25 SPEC.8.8 ZN	BOLT M12X1,25X25	VIS M12X1,25X25	SCHRAUBE M12X1,25X25	TORNILLO M12X1,25X25
11	M14710508R	SUPP.DENTI DI RACCOLTA L=100	COLLECTING RAKES SUPPORT L=100			
12	M14712508R	SUPP.DENTI DI RACCOLTA L=120	COLLECTING RAKES SUPP.			
13	M14714508R	SUPP.DENTI DI RACCOLTA L=140	COLLECTING RACKET SUPP.			
14	M14716508R	SUPP.DENTI DI RACCOLTA L=160	COLLECTING RAKES SUPP.			
15	M14718508R	SUPP.DENTI DI RACCOLTA L=180	COLLECTING RAKES SUPP.			
16	M14720508R	SUPP.DENTI DI RACCOLTA L=200	COLLECTING RAKES SUPP.			
17	T21005015R	ROSTRO	COLLECTING RAKE	DENT DE RATEAU	SCHNABEL	ROSTRO
18	F02200374R	COPIGLIA R 4X 82 ZN	SPRING SPLIT PIN 4X82	GOUPILLE 4X82	SPLINT 4X82	PASADOR 4X82
19	F01010283R	VITE M12X1,25X30 U5740 8.8ZN	SCR. M12X1,25X30 U5740 8.8ZN	VIS M 12X1,25X30	SCHRAUBE M 12X1,25X30	TORNILLO M 12X1,25X30
20	F01220047R	DADO M12X1,25 D980 8ZN	NUT M12X1,25 D980 8ZN	ECROU M12X1,25 D980 8 ZN	MUTTER M12X1,25 D980 8 ZN	TUERCA M12X1,25 D980 8 ZN
21	F01410076R	ROS.M12 13X 24X2,5 U6592 ZN	WASHER 12 13X 24X2,5 U6592 ZN	RONDEL. M12 13X24X2,5 U6592 ZN	SCHEIBE M12 13X24X2,5 U6592 ZN	ARAND.M12 13X 24X2,5 U6592 ZN
22	F01010291R	VITE M12X1,25X40 U5740 8.8ZN	SCR. M12X1,25X40 U5740 8.8ZN	VIS M12X1,25X40 U5740 8.8 ZN	SCHR.M12X1,25X40 U5740 8.8 ZN	TORN. M12X1,25X40 U5740 8.8 ZN
23	M22410602R	RASCHIA FANGO BV 100 ZG	MUD SCRAPER BV 100	DECROTTOIR POUR BOUE BV 100	ABSTREIFER FUR SCHLAMM BV 100	RASCADOR PARA FANGO BV 100
24	M22412602R	RASCHIA FANGO BV 120 ZG	MUD SCRAPER BV 120	DECROTTOIR POUR BOUE BV 120	ABSTREIFER FUR SCHLAMM BV 120	RASCADOR PARA FANGO BV 120
25	M22414602R	RASCHIA FANGO BV 140 ZG	MUD SCRAPER BV 140	DECROTTOIR POUR BOUE BV 140	ABSTREIFER FUR SCHLAMM BV 140	RASCADOR PARA FANGO BV 140
26	M22416602R	RASCHIA FANGO BV 160 ZG	MUD SCRAPER BV 160	DECROTTOIR POUR BOUE BV 160	ABSTREIFER FUR SCHLAMM BV 160	RASCADOR PARA FANGO BV 160
27	M22417602R	RASCHIA FANGO BV 170 ZG	MUD SCRAPER BV 170	DECROTTOIR POUR BOUE BV 170	ABSTREIFER FUR SCHLAMM BV 170	RASCADOR PARA FANGO BV 170
28	M22419602R	RASCHIA FANGO BV 190 ZG	MUD SCRAPER BV 190	DECROTTOIR POUR BOUE BV 190	ABSTREIFER FUR SCHLAMM BV 190	RASCADOR PARA FANGO BV 190
29	M30400619R	SUPPORTO RASCHIA RULLO	SCRAPER SUPPORT			
30	F01010320R	VITE M14X1,5X50 U5740 8.8ZN	SCR. M14X1,5X50 U5740 8.8ZN			
31	F01220059R	DADO M14X1,5 D980 8ZN	NUT M14X1,5 D980 8ZN	ECROU M14X 1,5 D980 8 ZN	MUTTER M14X 1,5 D980 8 ZN	TUERCA M14X 1,5 D980 8 ZN

TAV. 120

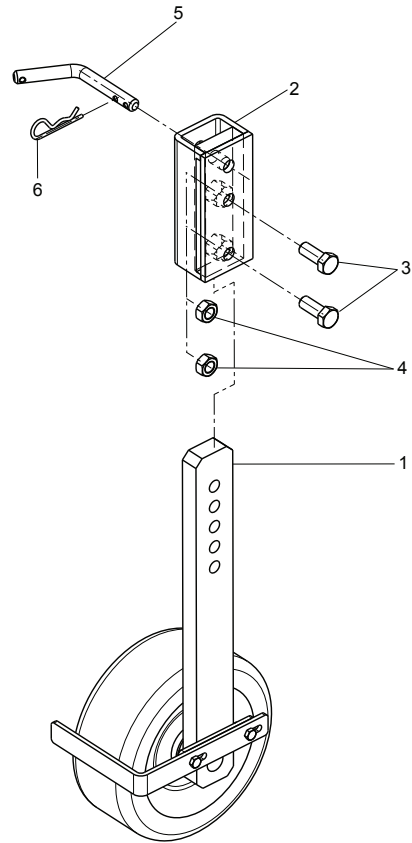

AVANZAMENTO
DIRECTION

OPTIONAL

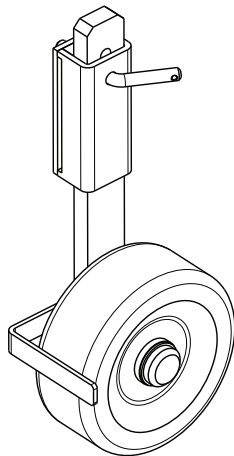

AVANZAMENTO
DIRECTION

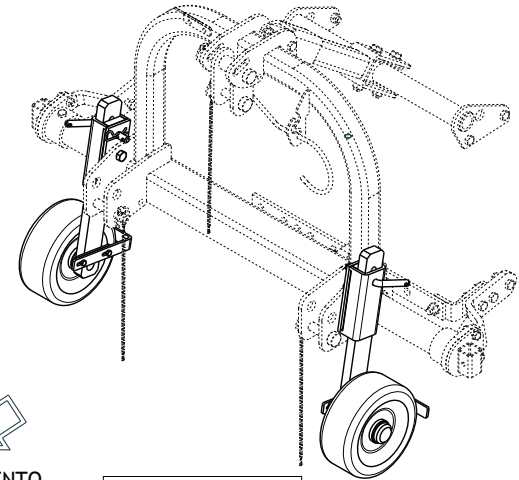

AVANZAMENTO
DIRECTION

CASTELLO SPOSTABILE
OFFSET VERSION

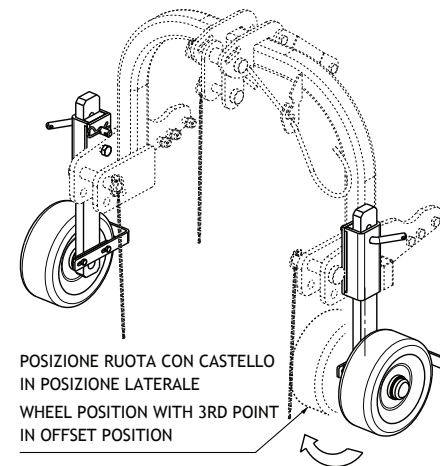

POSIZIONE RUOTA CON CASTELLO
IN POSIZIONE LATERALE
WHEEL POSITION WITH 3RD POINT
IN OFFSET POSITION

CASTELLO FISSO
FIXED VERSION

**ROUTE ANTERIORI
FRONT WHEELS**

TAV. 120

Pos.	Cod.	Descrizione	Description	Benennung	Description	Description
1	M14700552R	RUOTA ANTERIORE D=100	FRONT WELL D=100			
2	M09700552R	SUPPORTO	SUPPORT			
3	F01010339R	VITE M16X1,5X40 U5740 8.8ZN	SCR. M16X1,5X40 U5740 8.8ZN	VIS M 16X1,5X40	SCHRAUBE M 16X1,5X40	TORNILLO M 16X1,5X40
4	F01220070R	DADO M16X1,5 D980 10ZN	NUT M16X1,5 D980 8ZN	ECRO.M16X1,5 D980 8ZN	MUTTER M16X1,5 D980 8ZN	TUER.M16X1,5 D980 8ZN
5	M26100713R	PERNO BLOCCAGGIO RUOTA	WHEEL ADJUSTER PIN	GOIJON	BOLZEN	PERNO
6	F02200374R	COPIGLIA R 4X 82 ZN	SPRING SPLIT PIN 4X82	GOUPILLE 4X82	SPLINT 4X82	PASADOR 4X82

TAV. 130

WALTERSCHEID

STANDARD

BRAVA 100

BRAVA 120

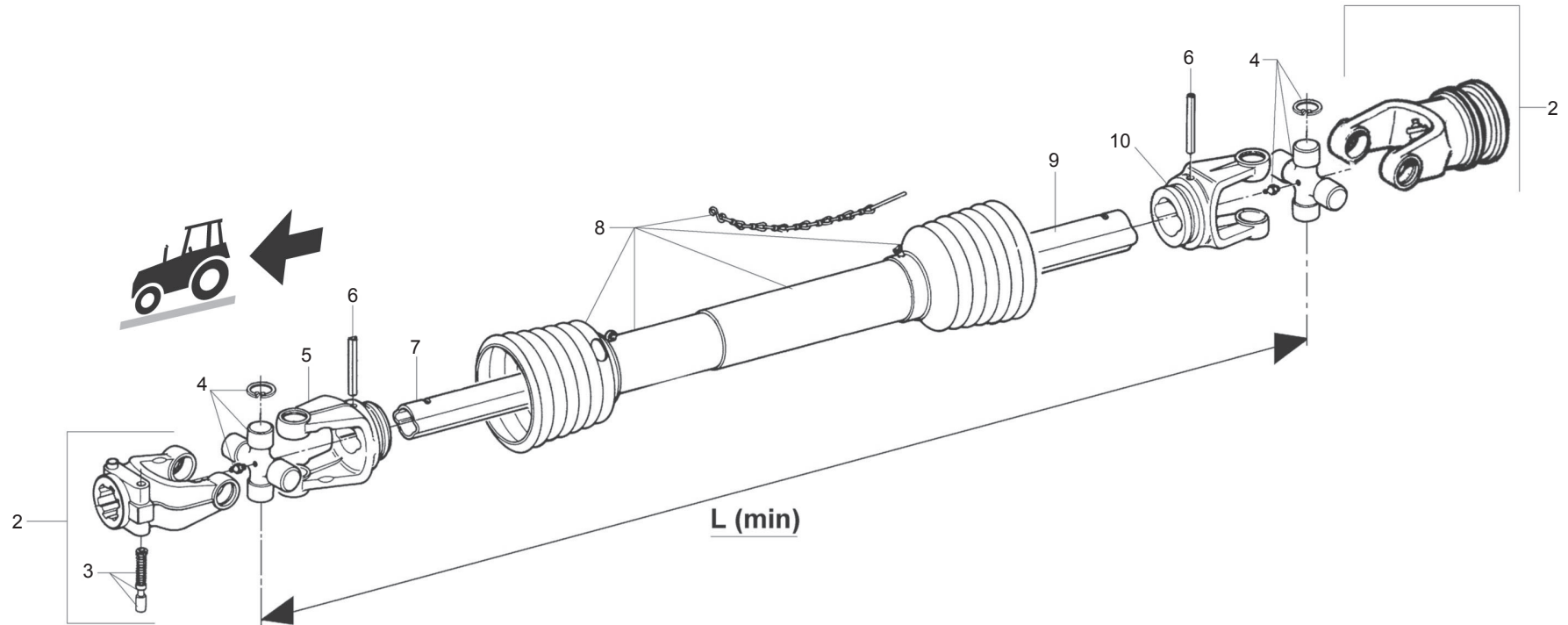
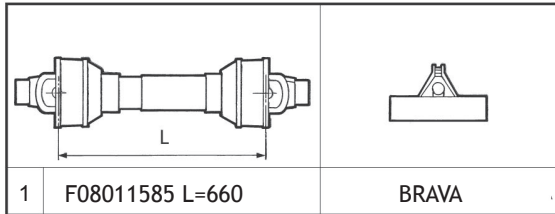

**ALBERO CARDANICO WALTERSCHEID
WALTERSCHEID CARDAN SHAFT**

TAV. 130

Pos.	Cod.	Descrizione	Description	Benennung	Description	Description
1	F08011585R	CARD.GKN 181864	UNIVERSAL P T O SHAFT	ARBRE A CARDAN	GELENKWELLE	ARBOL CARDANICO
2	F08010465R	FORCELLA COMPLETA DI PULSANTI	LINKAGE FORK	FOURCHE ATTELAGE	GABELSTUECK	HORQUILLAATAQUE
3	F08011168R	339107 PULSANTE	YOKE PIN 339107	POUSSOIR COMPL.	DRUCKKNOPF KOMPL.	PULSADOR COMPL.
4	F08010675R	CROCIERA COMPLETA	SPIDER ASSY	CROISIERE COMPL.	GELENKKREUZ KOMPL.	CRUCETA COMPLETA
5	F08010605R	FORCELLA PER TUBO INTERNO	FORK FOR INTERNAL PIPE	FOURCHE TUBE INTERIEUR	GABELSTUECK FUER INNENROHR	HORQUILLA TUBO INTERIOR
6	F02100168R	SPINA E.P. 10X 65 U6873 C70 BR	ELASTIC PIN 10X75	GOUJON ELASTIQUE 10X75	SPANNHUELSE 10X75	ESPINA ELASTICA 10X75
7	F08010796R	TUBO INTERNO	INNER TUBE	TUBE PROFILE INTERIEUR	PROFILIERTES INNENROHR	TUBO PERFILADO INTERNO
8	F08010835R	PROTEZIONE COMPLETA	PROTECTION ASSY	PROTECTION COMPL.	KOMPL. SCHUTZ	PROTECCION COMPL.
9	F08010776R	TUBO ESTERNO	OUTER TUBE	TUBE PROFILE EXTERIEUR	PROFILIERTES AUSSENROHR	TUBO PERFILADO EXTERNO
10	F08010615R	FORCELLA PER TUBO ESTERNO	FORK FOR EXTERNAL PIPE	FOURCHE TUBE EXTERIEUR	GABELSTUECK FUER AUSSENROHR	HORQUILLA TUBO EXTERNO

TAV. 140

WALTERSCHEID

STANDARD

BRAVA 140
BRAVA 160
BRAVA 180
BRAVA 200

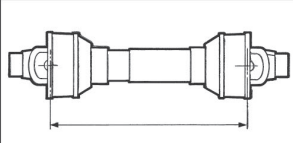
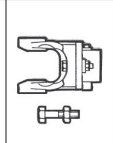
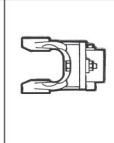
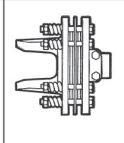
			
7 F08011591 L=660 3/8" Z6	-	X	-

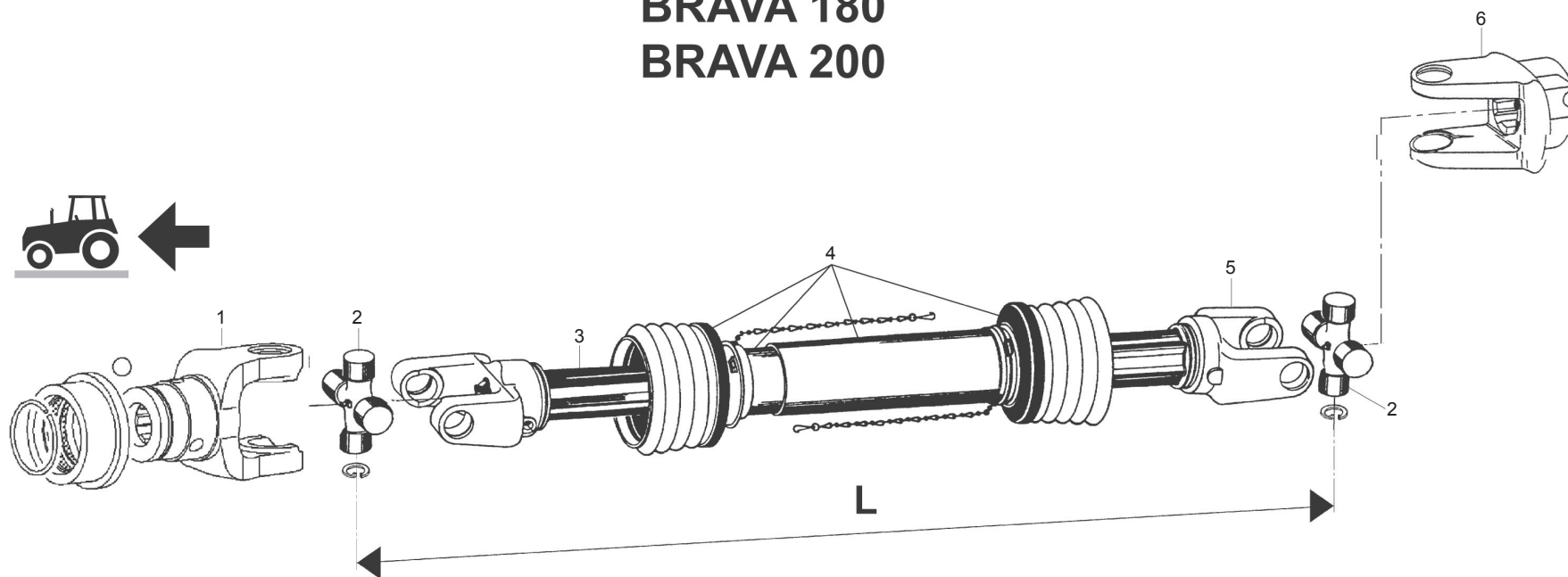

**ALBERO CARDANICO WALTERSCHEID
WALTERSCHEID CARDAN SHAFT**

TAV. 140

Pos.	Cod.	Descrizione	Description	Benennung	Description	Description
1	F08000003R	FORCELLA 1 3 8 Z6	LINKAGE FORK 1 3 8 Z6	FOURCHE ATTELAGE 1 3 8 Z6	GABELSTUECK 1 3 8 Z6	HORQUILLA ATAQUE 1 3 8 Z6
2	F08010683R	CROCIERA COMPLETA W2300	SPIDER ASSY	CROISIERE COMPL.	GELENKKREUZ KOMPL.	CRUCETA COMPL.
3	F08010814R	FORCELLA TUBO PROFILATO INT.	YOKE WITH EXTERNAL PIPE		GABEL	
4	F08010851R	PROTEZIONE COMPLETA	PROTECTION ASSY	PROTECTION COMPL.	KOMPL. SCHUTZ	PROTECCION COMPL.
5	F08010544R	FORCELLA CON TUBO ESTERNO SALD	YOKE WITH EXTER. WELDING PIPE		GABEL	
6	F08010457R	FORCELLA COMPLETA DI PULSANTE	LINKAGE FORK	FOURCHE ATTELAGE	GABELSTUECK	HORQUILLA ATAQUE
7	F08011591R	CARD.GKN 180356	UNIVERSAL PTO SHAFT GKN 180356			

TAV. 150

BONDIOLI



OPTIONAL

BRAVA 140

BRAVA 160

BRAVA 180

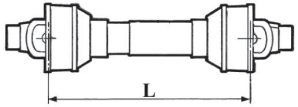
BRAVA 200

	
6 F08011822 L=710	BRAVA

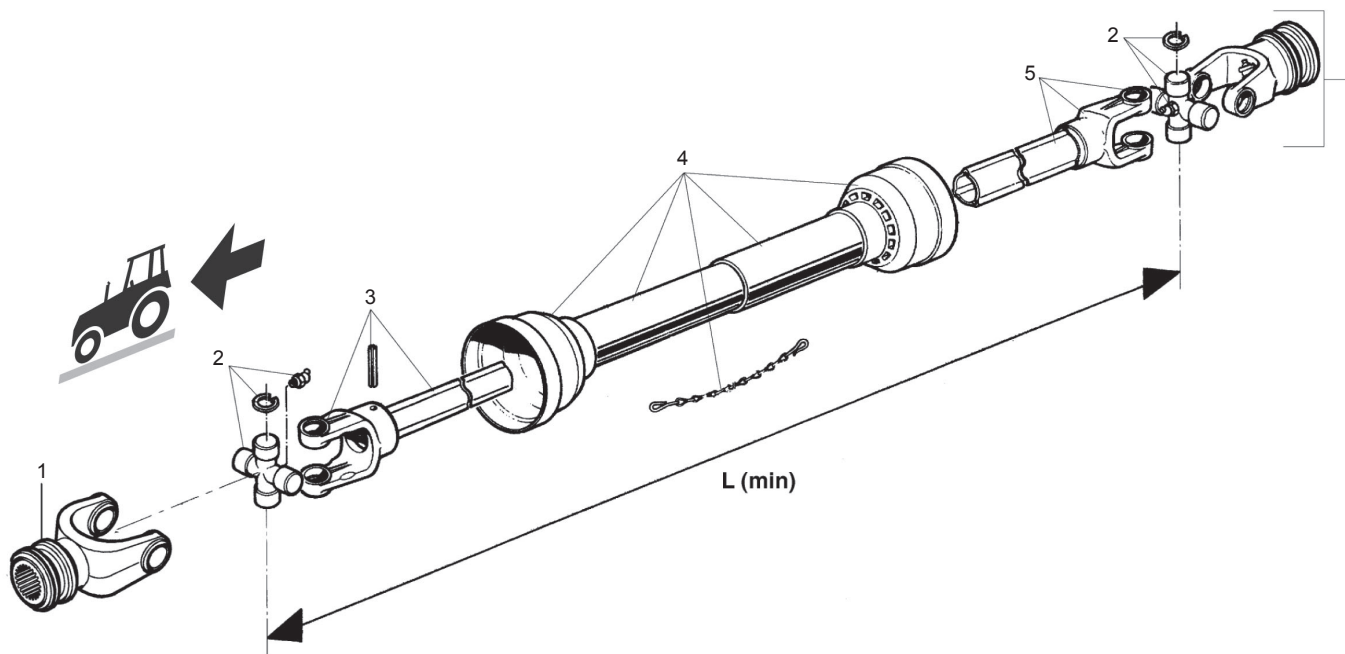

**ALBERO CARDANICO BONDIOLI
BONDIOLI CARDAN SHAFT**

TAV. 150

Pos.	Cod.	Descrizione	Description	Benennung	Description	Description
1	F08010471R	FORCELLA ATTACCO	LINKAGE FORK	FOURCHE ATTELAGE	GABELSTUECK	HORQUILLA ATAQUE
2	F08010685R	CROCIERA COMPLETA	SPIDER ASSY	CROISIERE COMPL.	GELENKKREUZ KOMPL.	CRUCETA COMPLETA
3	F08010559R	FORCELLA TUBO INTERNO	FORK WITH INTERNAL PIPE	FOURCHE AVEC TUBE INTERIEUR	GABELST. INNENROHR	HORQUILLA TUBO INTERIOR
4	F08010834R	PROT. COMPLETA BOS8	PROTECTION ASSY	PROTECTION COMPL.	KOMPL. SCHUTZ	PROTECCION COMPL.
5	F08010489R	08006021 FORCELLA TUBO EST.	FORK WITH EXTERNAL PIPE	FOURCHE AVEC TUBE EXT.	GABELST. AUSSENROHR	HORQUILLA TUBO EXT.
6	F08011657R	ALBERO CARDANICO COMPLETO	COMPLETE PTO SHAFT			

**USATE SEMPRE RICAMBI ORIGINALI
ALWAYS USE ORIGINAL SPARE PARTS
IMMER DIE ORIGINAL-ERSATZTEILE VERWENDEN
EMPLOYEZ TOUJOURS LES PIECES DE RECHANGE ORIGINALES
UTILIZAR SIEMPRE REPUESTOS ORIGINALES**



Servizio Assistenza Tecnica - After Sales Service

+39 049 9289966

Servizio Ricambi - Spare Parts Service

+39 049 9289888

DEALER:



MASCHIO GASPARDO SpA

Registered Office and Production Plant

Via Marcello, 73 - 35011 Campodarsego (Padova) - Italy

Tel. +39 049 9289810

Fax +39 049 9289900

info@maschio.com

www.maschionet.com

MASCHIO DEUTSCHLAND GMBH

Außere Nürnberger Straße 5

D - 91177 Thalmässing - Deutschland

Tel. +49 (0) 9173 79000

Fax +49 (0) 9173 790079

dialog@maschio.de

www.maschionet.de

MASCHIO FRANCE Sarl

1 rue Denis Papin ZA

F - 45240 La Ferte St. Aubin

France

Tel. +33 (0) 2.38.64.12.12

Fax +33 (0) 2.38.64.66.79

info@maschio.fr

000 MASCHIO-GASPARDO РУССИЯ

04130, Россия,

Волгоградская область,

г. Волжский, ул. Пушкина, 117 «б».

Тел.: +7 8443 203100

факс: +7 8443 203101

e-mail: info@maschio.ru

MASCHIO GASPARDO SpA

Production Plant

Via Mussons, 7 - 33075 Morsano al Tagliamento (PN) - Italy

Tel. +39 0434 695410

Fax +39 0434 695425

info@gaspardo.it

MASCHIO GASPARDO NORTH AMERICA Inc.

112 3rd Avenue East

DeWitt - IA 52742

Ph. +1 563 6596400

Fax +1 563 6596404

info@maschio.us

MASCHIO-GASPARDO ROMANIA S.R.L.

Strada Înfrăţirii, F.N.

315100 Chisineu-Cris (Arad) -România

Tel. +40 257 307030

Fax +40 257 307040

info@maschio.ro

MASCHIO IBERICA S.L.

MASCHIO-GASPARDO POLAND

MASCHIO-GASPARDO UCRAINA

GASPARDO-MASCHIO TURCHIA

MASCHIO-GASPARDO CINA

MASCHIO-GASPARDO INDIA

MASCHIO-GASPARDO KOREA