

For use with the following starting serial numbers:

Model      Serial Number

All Models      3000



**ATTENTION:**  
ALL WARRANTY WORK **MUST** BE APPROVED  
BY BROWN MFG. CORP.

**BEFORE WORK BEGINS**



## Owner / Operator Manual



**HEAVY DUTY SINCE 1944**

6001 E. Hwy 27 - Ozark, AL 36360

334.795.6603 - Fax: 334.795.3029

[www.brownmfgcorp.com](http://www.brownmfgcorp.com)

### **⚠ WARNING**



Before operating your machine, stop and read this owners manual. Do not attempt to operate the unit until you fully understand the material covered in this manual. Without the knowledge contained in this manual, injury or death can result.

### **Copyright Information**

Copyright ©2000 Brown Manufacturing Corporation, Ozark, Alabama. All photos and illustrations are property of Brown Manufacturing Corporation. This publication may be freely reproduced, either in whole or in part, provided that the content herein is not altered. We encourage you to make copies of this manual and to distribute it to every operator of the machine. Additional copies are also available from Brown Manufacturing Corporation or via our web site at [www.brownmfgcorp.com](http://www.brownmfgcorp.com).

### **Cover**

Illustrated: Models TS-100 and TSG-200

### **Disclaimer**

Due to engineering improvements and revision of product specifications, the information contained in this manual is subject to change without notice.

# Contents

Warranty .....	4
Registration .....	6
Equipment Safety .....	9
Assembly.....	18
Operation.....	20
Maintenance .....	22
Troubleshooting .....	28
Specifications .....	29
Replacement Parts.....	30

## BROWN MANUFACTURING CORP.

## Limited Warranty

## 1. LIMITED WARRANTIES

- 1.01. Brown Manufacturing Corp. warrants for one year from the purchase date to the original non-commercial, governmental, or municipal purchaser ("Purchaser") and warrants for ninety (90) days to the original commercial or industrial purchaser ("Purchaser") that the goods purchased are free from defects in material or workmanship.
- 1.02. Manufacturer will replace for the Purchaser any part or parts found, upon examination at its factory, to be defective under normal use and service due to defects in material or workmanship.
- 1.03. This limited warranty does not apply to any part of the goods which has been subjected to improper or abnormal use, negligence, alteration, modification, or accident, damaged due to lack of maintenance or use of wrong oil or expendable items such as blades, shields, guards, or tires except as specifically found in your Operator's Manual.
- 1.04. Except herein, no employee, agent, Dealer, or other person is authorized to give warranties of any nature on behalf of the Manufacturer.

## 2. REMEDIES AND PROCEDURES

- 2.01. This limited warranty is not effective unless the Purchaser returns the Registration and Warranty Form to Manufacturer within 30 days of purchase.
- 2.02. Purchaser claims must be made in writing to the Authorized Dealer ("Dealer") from whom Purchaser purchased the goods or an approved Authorized Dealer ("Dealer") within 30 days after Purchaser learns of the facts on which the claim is based.
- 2.03. Purchaser is responsible for returning the goods in question to the Dealer.
- 2.04. If after examining the goods and/or parts in question, Manufacturer finds them to be defective under normal use and service due to defects in material or workmanship, Manufacturer will:
- (a) Repair or replace the defective goods or part(s) or
- (b) Reimburse Purchaser for the cost of the part(s) and reasonable labor charges (as determined by Manufacturer) if Purchaser paid for the repair and/or replacement prior to the final determination of applicability of the warranty by Manufacturer. (The choice of remedy shall belong to Manufacturer).
- 2.05. Purchaser is responsible for any labor charges exceeding a reasonable amount as determined by Manufacturer and for returning the goods to the Dealer, whether or not the claim is approved. Purchaser is responsible for the transportation cost for the goods or part(s) from the Dealer to the factory.

## 3. LIMITATION OF LIABILITY

- 3.01. MANUFACTURER DISCLAIMS ANY EXPRESS (EXCEPT AS SET FORTH HEREIN) AND IMPLIED WARRANTIES FOR A PARTICULAR PURPOSE.
- 3.02. MANUFACTURER MAKES NO WARRANTY AS TO THE DESIGN, CAPABILITY, CAPACITY, OR SUSTAINABILITY FOR USE OF THE GOODS.
- 3.03. EXCEPT AS PROVIDED HEREIN, MANUFACTURER SHALL HAVE NO LIABILITY OR RESPONSIBILITY TO PURCHASER OR ANY OTHER PERSON OR ENTITY WITH RESPECT TO ANY LIABILITY, LOSS, OR DAMAGE CAUSED OR ALLEGED TO BE CAUSED DIRECTLY OR INDIRECTLY BY THE GOODS INCLUDING, BUT NOT LIMITED TO, ANY INDIRECT, SPECIAL, CONSEQUENTIAL, OR INCIDENTAL DAMAGES RESULTING FROM THE USE OR OPERATION OF THE GOODS OR ANY BREACH OF THIS WARRANTY. NOT WITHSTANDING THE ABOVE LIMITATIONS AND WARRANTIES, MANUFACTURER'S LIABILITY HEREUNDER FOR DAMAGES INCURRED BY PURCHASER OR OTHERS SHALL NOT EXCEED THE PRICE OF THE GOODS.
- 3.04. NO ACTION ARISING OUT OF ANY CLAIMED BREACH OF THIS WARRANTY OR TRANSACTIONS UNDER THIS WARRANTY MAY BE BROUGHT MORE THAN TWO (2) YEARS AFTER THE CAUSE OF ACTION HAS OCCURRED.

## 4. MISCELLANEOUS

- 4.01. Proper venue for any lawsuits arising from or related to this limited warranty shall be only in Dale County, Alabama.
- 4.02. Manufacturer may waive compliance with any of the terms of this limited warranty, but no waiver of any terms shall be deemed to be a waiver of any other term.
- 4.03. If any provision of this limited warranty shall violate any applicable law and is held to be unenforceable, then the invalidity of such provision shall not invalidate any other provisions herein.
- 4.04. Applicable law may provide rights and benefits to Purchaser in addition to those provided herein.

KEEP FOR YOUR RECORDS (ATTENTION: READ YOUR OPERATOR'S MANUAL)

ATTENTION: Purchaser should fill in the blanks below for his reference when buying repair parts and/or for proper machine identification when applying for warranty.

Brown Model \_\_\_\_\_ Serial Number \_\_\_\_\_

Date Purchased \_\_\_\_\_ Dealer \_\_\_\_\_

Brown Manufacturing Corp.  
6001 E. Hwy 27  
Ozark, AL 36360  
800-633-8909  
brown@brownmfgcorp.com



## TO THE OWNER/OPERATOR/DEALER

In addition to the standard Limited Warranty shown on the facing page, Brown Manufacturing Corp. also provides:

- 1.) ONE-YEAR (12 months) {or 90 days for Commercial/Industrial Users} LIMITED WARRANTY on the DRIVELINE components provided they have been properly maintained† and have not been subjected to abuse or misuse.
- 2.) FIVE-YEAR (60 months) LIMITED WARRANTY\* on GEARBOX components provided they have been properly maintained† and have not been subjected to abuse or misuse except as limited below.

### \* WARRANTY LIMITATIONS - GEARBOX

- A) Warranty is ONE-YEAR (12 months) for Seals (After one year, seals are considered to be WEARING PARTS and replacement is user's responsibility).
- B) User's Gearboxes may be rebuilt by Brown Manufacturing Corp. or replaced by new or rebuilt Gearboxes at the option of Brown Manufacturing Corp.

† NOTE — "properly maintained" specifically includes, but is not limited to:

- A) Running Gearboxes with the proper amount of the correct lubricant.
- B) Adjusting Slip Clutches correctly to provide protection for Driveline and Gearbox Components.

To keep your implement running efficiently and safely read your manual thoroughly and follow these directions and the Safety Messages in this Manual. The Table of Contents clearly identifies each section where you can easily find the information you need.

The OCCUPATIONAL SAFETY AND HEALTH ACT (1928.51 Subpart C) makes these minimum safety requirements of tractor operators:

### REQUIRED OF THE OWNER:

1. Provide a Roll-Over-Protective Structure that meets the requirements of this Standard, and
2. Provide Seat belts that meet the requirements of this paragraph of this Standard and SAE J4C; and
3. Ensure that each employee uses such Seat belt while the tractor is moving; and
4. Ensure that each employee tightens the Seat belt sufficiently to confine the employee to the protected provided by ROPS.

### REQUIRED OF THE OPERATOR:

1. Securely fasten seat belt if the tractor has a ROPS.
2. Where possible, avoid operating the tractor near ditches, embankments, and holes.
3. Reduce speed when turning, crossing slopes, and on rough, slick, or muddy surfaces.
4. Stay off slopes too steep for safe operation.
5. Watch where you are going — especially at row ends, on roads, and around trees.
6. Do not permit others to ride.
7. Operate the tractor smoothly — no jerky turns, starts, or stops.
8. Hitch only to the drawbar and hitch points recommended by the tractor manufacturer.
9. When the tractor is stopped, set brakes securely and use park lock, if available.

Please complete the form below and mail to: Brown Mfg. Corp. - 6001 E. Hwy. 27 - Ozark, AL 36360  
 6 BROWN MANUFACTURING CORP. ® WARRANTY REGISTRATION INFORMATION

Brown Model \_\_\_\_\_ Serial No. \_\_\_\_\_ Purchase Date (mm/dd/yy) \_\_\_/\_\_\_/\_\_\_  
 Purchaser Last Name \_\_\_\_\_ First Name \_\_\_\_\_ M.I. \_\_\_\_\_  
 Street & No., RFD,  
 Box, &/or Apt. No. \_\_\_\_\_  
 City: \_\_\_\_\_ State or Province: \_\_\_\_\_ Zip \_\_\_\_\_  
 Dealer: \_\_\_\_\_  
 City: \_\_\_\_\_ State or Province \_\_\_\_\_ Zip \_\_\_\_\_

. I have informed the Purchaser of this product of Warranty terms, provisions, and procedures that are applicable, reviewed the contents of the Operator’s Manual including safety equipment, safe operation, and maintenance, reviewed the Safety Signs on implement (and tractor if possible), and Purchaser’s responsibility to train his operators in safe operation.

. IMPLEMENTS: I have explained that Deflectors, Chain Guards, or Solid Skirts must be maintained in good repair and installed except in areas where persons, vehicles, livestock, or other property will not be endangered by thrown objects and where such safety equipment would prevent the TreeSaw’s reasonable performance of its assigned task.

. DRIVELINES: I have made certain that all driveline, gearbox, and other shields are in good repair and fastened securely in place to prevent injuries from entanglement or thrown objects.

Dealer’s Signature: \_\_\_\_\_ Date: \_\_\_\_\_

I have been instructed on the paragraphs above, received and have been instructed on the contents of the Operator’s Manual including safety signs, safety equipment, safe operation, maintenance, and the potential hazards of unauthorized alterations or modifications of the product. I have been informed of the warranty provisions and know that the warranty is not in effect until this form is received by Brown Manufacturing Corp.

I understand the Implement Guarding statements above and the potential hazards of operating without such guards. I understand that the operator is responsible for the safety of others in the area. I have examined the product and accept it as being complete and in satisfactory condition with all required guards.

CUSTOMER COPY

Purchaser’s Signature: \_\_\_\_\_ Date: \_\_\_\_\_

**PRE-DELIVERY SERVICE  
 CHECK AND ADJUST OR LUBRICATE AS REQUIRED**

See Operator’s Manual for Details

Inspection performed — Warranty and Safety Procedures Explained — Installation Complete

<input type="checkbox"/> Gearbox (Oil Levels)	<input type="checkbox"/> Drivelines (Proper Length and Lubrication)
	<input type="checkbox"/> Gearbox Vent Plugs (Location and Operation)
	<input type="checkbox"/> Deflectors Front and Rear
<input type="checkbox"/> Shredding Attachments	<input type="checkbox"/> Correct Blade Rotation Direction
<input type="checkbox"/> All Lubrication Points Greased	<input type="checkbox"/> All Bolts — Pins and Nuts (Proper Torque)
	<input type="checkbox"/> Cutting Height
<input type="checkbox"/> Protective Shields (Operation and Installation)	<input type="checkbox"/> Driveline Clutch (Torque Limiter) (Adjust and Run In)
<input type="checkbox"/> Safety Decals (Installed)	<input type="checkbox"/> Operator’s Manual (Supplied)
<input type="checkbox"/> Tractor PTO Shield (Installed)	<input type="checkbox"/> S.M.V. Emblem (Installed if Needed)

Purchaser’s Signature \_\_\_\_\_ Date \_\_\_\_\_ Dealer’s Signature \_\_\_\_\_ Date \_\_\_\_\_

Please complete the form below and mail to: Brown Mfg. Corp. - 6001 E. Hwy. 27 - Ozark, AL 36360  
BROWN MANUFACTURING CORP. ® WARRANTY REGISTRATION INFORMATION

Brown Model \_\_\_\_\_ Serial No. \_\_\_\_\_ Purchase Date (mm/dd/yy) \_\_\_\_/\_\_\_\_/\_\_\_\_

Purchaser Last Name \_\_\_\_\_ First Name \_\_\_\_\_ M.I. \_\_\_\_\_

Street & No., RFD,  
Box, &/or Apt. No. \_\_\_\_\_

City: \_\_\_\_\_ State or Province: \_\_\_\_\_ Zip \_\_\_\_\_

Dealer: \_\_\_\_\_

City: \_\_\_\_\_ State or Province \_\_\_\_\_ Zip \_\_\_\_\_

. I have informed the Purchaser of this product of Warranty terms, provisions, and procedures that are applicable, reviewed the contents of the Operator’s Manual including safety equipment, safe operation, and maintenance, reviewed the Safety Signs on implement (and tractor if possible), and Purchaser’s responsibility to train his operators in safe operation.

. IMPLEMENTS: I have explained that Deflectors, Chain Guards, or Solid Skirts must be maintained in good repair and installed except in areas where persons, vehicles, livestock, or other property will not be endangered by thrown objects and where such safety equipment would prevent the TreeSaw’s reasonable performance of its assigned task.

. DRIVELINES: I have made certain that all driveline, gearbox, and other shields are in good repair and fastened securely in place to prevent injuries from entanglement or thrown objects.

Dealer’s Signature: \_\_\_\_\_ Date: \_\_\_\_\_

I have been instructed on the paragraphs above, received and have been instructed on the contents of the Operator’s Manual including safety signs, safety equipment, safe operation, maintenance, and the potential hazards of unauthorized alterations or modifications of the product. I have been informed of the warranty provisions and know that the warranty is not in effect until this form is received by Brown Manufacturing Corp.

I understand the Implement Guarding statements above and the potential hazards of operating without such guards. I understand that the operator is responsible for the safety of others in the area. I have examined the product and accept it as being complete and in satisfactory condition with all required guards.

CUSTOMER COPY

Purchaser’s Signature: \_\_\_\_\_ Date: \_\_\_\_\_

**PRE-DELIVERY SERVICE  
CHECK AND ADJUST OR LUBRICATE AS REQUIRED**

See Operator’s Manual for Details

Inspection performed — Warranty and Safety Procedures Explained — Installation Complete

<input type="checkbox"/> Gearbox (Oil Levels)	<input type="checkbox"/> Drivelines (Proper Length and Lubrication)
	<input type="checkbox"/> Gearbox Vent Plugs (Location and Operation)
	<input type="checkbox"/> Deflectors Front and Rear
<input type="checkbox"/> Shredding Attachments	<input type="checkbox"/> Correct Blade Rotation Direction
<input type="checkbox"/> All Lubrication Points Greased	<input type="checkbox"/> All Bolts — Pins and Nuts (Proper Torque)
	<input type="checkbox"/> Cutting Height
<input type="checkbox"/> Protective Shields (Operation and Installation)	<input type="checkbox"/> Driveline Clutch (Torque Limiter) (Adjust and Run In)
<input type="checkbox"/> Safety Decals (Installed)	<input type="checkbox"/> Operator’s Manual (Supplied)
<input type="checkbox"/> Tractor PTO Shield (Installed)	<input type="checkbox"/> S.M.V. Emblem (Installed if Needed)

Purchaser’s Signature \_\_\_\_\_ Date \_\_\_\_\_ Dealer’s Signature \_\_\_\_\_ Date \_\_\_\_\_

**IMPORTANT NOTICE:**  
OWNER'S MANUAL STORAGE CONTAINER

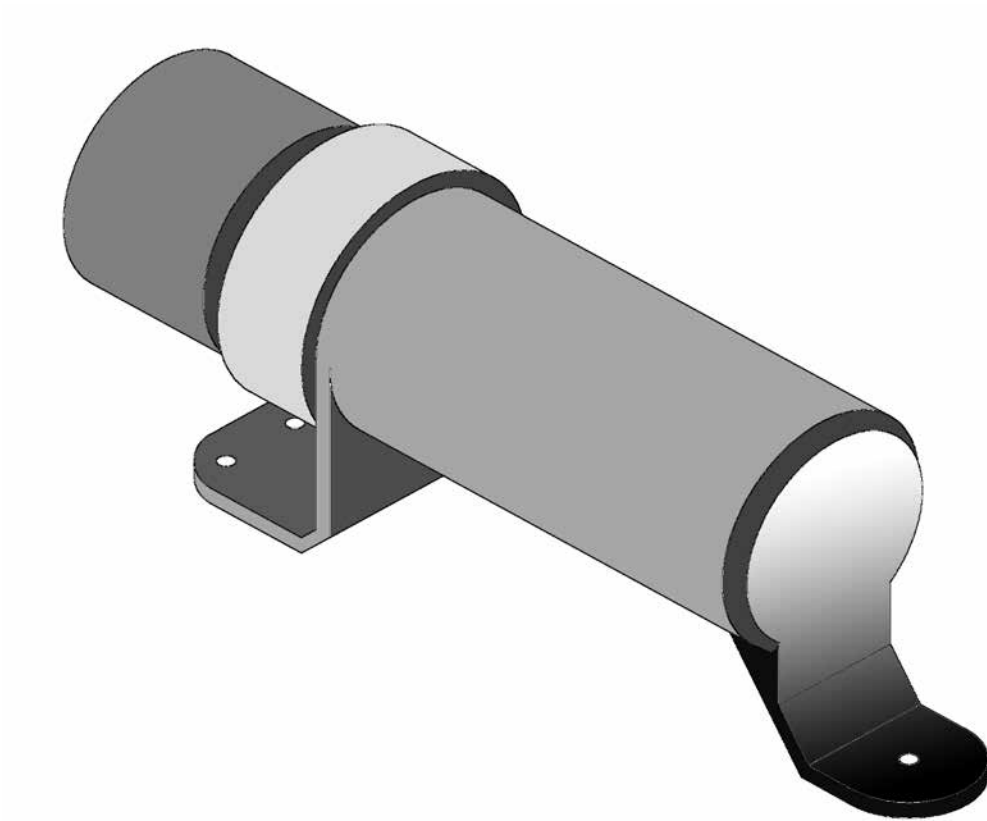



- \* Brown Manufacturing provides an Owner's Manual storage container on all equipment.
- \* This holder is mounted in a convenient location and provides the owner with the proper safety and operation information.
- \* Two (2) copies are provided with each unit.
- \* One copy is for the owner to have at office for review when not operating the equipment.
- \* Second copy is to stay with the unit at all times. This will provide the operator the information needed for safe and proper operation of the unit.
- \* If the Owner's Manual becomes lost or damaged, contact Brown Mfg. or your local Brown dealer for free replacement, or it can be downloaded and printed from our web site [www.brownmfgcorp.com](http://www.brownmfgcorp.com).



# Equipment Safety

## Warning: Read this manual before operation.

Operators of the equipment must read and understand this manual. Failure to read this manual and follow these safety and operating instructions could result in serious bodily injury or even death.

 <b>WARNING</b>	
	<p>Before operating your machine, stop and read this owners manual. Do not attempt to operate the unit until you fully understand the material covered in this manual. Without the knowledge contained in this manual, injury or death can result.</p>

**Each operator of the equipment should review this manual every six (6) months.** You are encouraged to duplicate this manual and to distribute it to each operator of the equipment for their training and reference. Additional copies are available from Brown Manufacturing Corporation.

## **IMPORTANT NOTICE:**

### OWNER'S MANUAL STORAGE CONTAINER

- \* Brown Manufacturing provides an Owner's Manual storage container on all equipment.
- \* This holder is mounted in a convenient location and provides the owner with the proper safety and operation information.
- \* Two (2) copies are provided with each unit.
- \* One copy is for the owner to have at office for review when not operating the equipment.
- \* Second copy is to stay with the unit at all times. This will provide the operator the information needed for safe and proper operation of the unit.
- \* If the Owner's Manual becomes lost or damaged, contact Brown Mfg. at 800-633-8909 or your local Brown dealer for free replacement, or can be downloaded and printed from our web site [www.brownmfgcorp.com](http://www.brownmfgcorp.com).

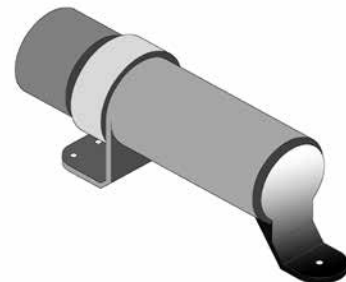

# Equipment Safety

## Recognize safety information

This is the safety alert symbol. When you see this symbol on your equipment or in this manual, be alert to the potential for personal injury or injury to others.



## Understand signal words

**DANGER** indicates an imminently hazardous situation which, if not avoided, will result in death or serious injury



**WARNING** indicates a hazardous situation which, if not avoided, could result in serious injury or death.



**CAUTION** indicates a potentially hazardous situation which, if not avoided, may result in minor or moderate injury.



**NOTICE** indicates information considered important but not directly hazard related. (e.g. security, hygiene, equipment or property damage).



## Follow safety instructions

- Read owner/operator manual.
- Replace missing or damaged safety decals.
- Safety decals and this manual must be considered a permanent part of your equipment.
- Should ownership of the equipment be transferred, this manual must also be transferred.
- Unauthorized modifications to the equipment are not recommended. This could impair the function, safety, and life of the machine.
- For any part of this manual that you do not understand, contact your dealer or Brown Manufacturing Corporation at (800) 633-8909.
- All implements with moving parts are potentially dangerous. Due to this fact, there is no substitute for a safe, knowledgeable operator. It is important that all persons operating this equipment read, understand, and follow the instructions provided in this manual.

**DO NOT OPERATE THIS UNIT IF YOU ARE UNDER THE INFLUENCE OF ALCOHOL, ILLEGAL DRUGS, OR ANY PRESCRIPTION OR OVER THE COUNTER MEDICATIONS THAT COULD CAUSE DROWSINESS, DIZZINESS, DISORIENTATION AND/OR IMPAIR YOUR ABILITY IN ANY WAY TO SAFELY OPERATE THE UNIT.**

**DO NOT OPERATE THIS UNIT IF YOU SUFFER FROM ANY PHYSICAL CONDITON OR DISABILITY THAT WOULD IMPAIR YOUR ABILITY TO OPERATE IT SAFELY.**

# Equipment Safety

## Safety Decals

The following safety decals should be attached to the equipment at all times. Should any decals become damaged or lost, it is the responsibility of the owner to replace it. Additional decals may be obtained from the dealer or Brown Manufacturing Corporation.

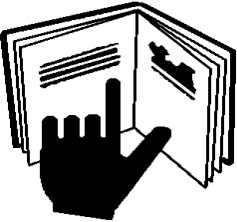
<b>! WARNING</b>		<b>! ADVERTENCIA</b>	
		Antes de probar la unidad por primera vez deben remitirse a las instrucciones contenidas en el manual.	
Read and understand owner's manual before operating unit.		<b>! ADVERTISSEMENT</b>	
		S'assurer de bien comprendre toutes les consignes du manuel de propriétaire avant d'utiliser la unité.	

Part No.: SD-010, All models.

<b>! DANGER</b>	
<b>THROWN OBJECT HAZARD</b>	
To prevent serious injury or death from thrown objects:	
 <ul style="list-style-type: none"> <li>• Stay clear when blade is turning.</li> <li>• Operate only with all guards installed and in good condition.</li> <li>• Stop operation if bystanders come within 300 feet.</li> </ul>	

Part No.: SD-001A, All models.

<b>! WARNING</b>
To prevent serious injury or death:
<ul style="list-style-type: none"> <li>• Operate only at 540 RPM PTO.</li> <li>• Keep guards and shields in place.</li> </ul>

SD-007A, Standard models\*.

\*All Brown TreeSaws are equipped for 540 RPM PTOs as standard. Equipping for 1000 RPM PTOs is an option, however; in such a case, use safety decal SD-008A.

# Equipment Safety

## Safety Decals (continued)

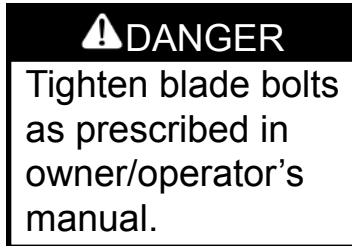

Part No.: SD-002, All models.



Part No.: DC-3-5-018, All models.

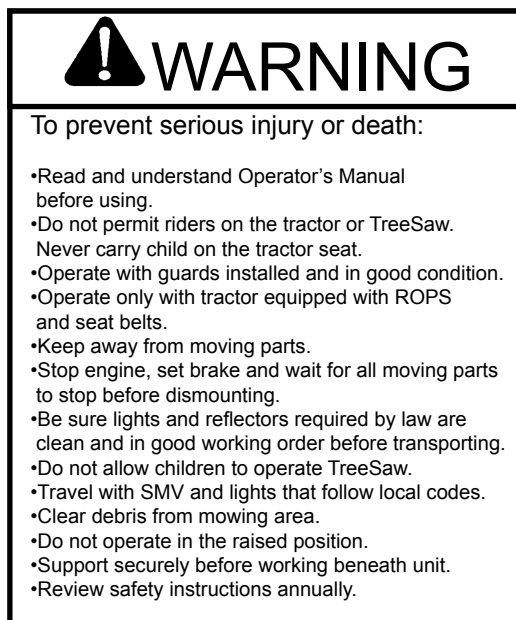

Part No.: SD-009A, All models.



Part No.: SD-SW2, All models.

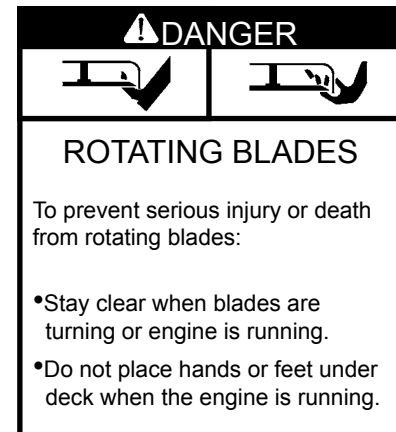

Part No.: SD-005A, All models.



Part No.: SD-006A, All models.

# Equipment Safety

## Safety Decals (*continued*)

Safety decals must be positioned as illustrated below. Use this diagram to correctly identify missing, damaged, or illegible decals for replacement.

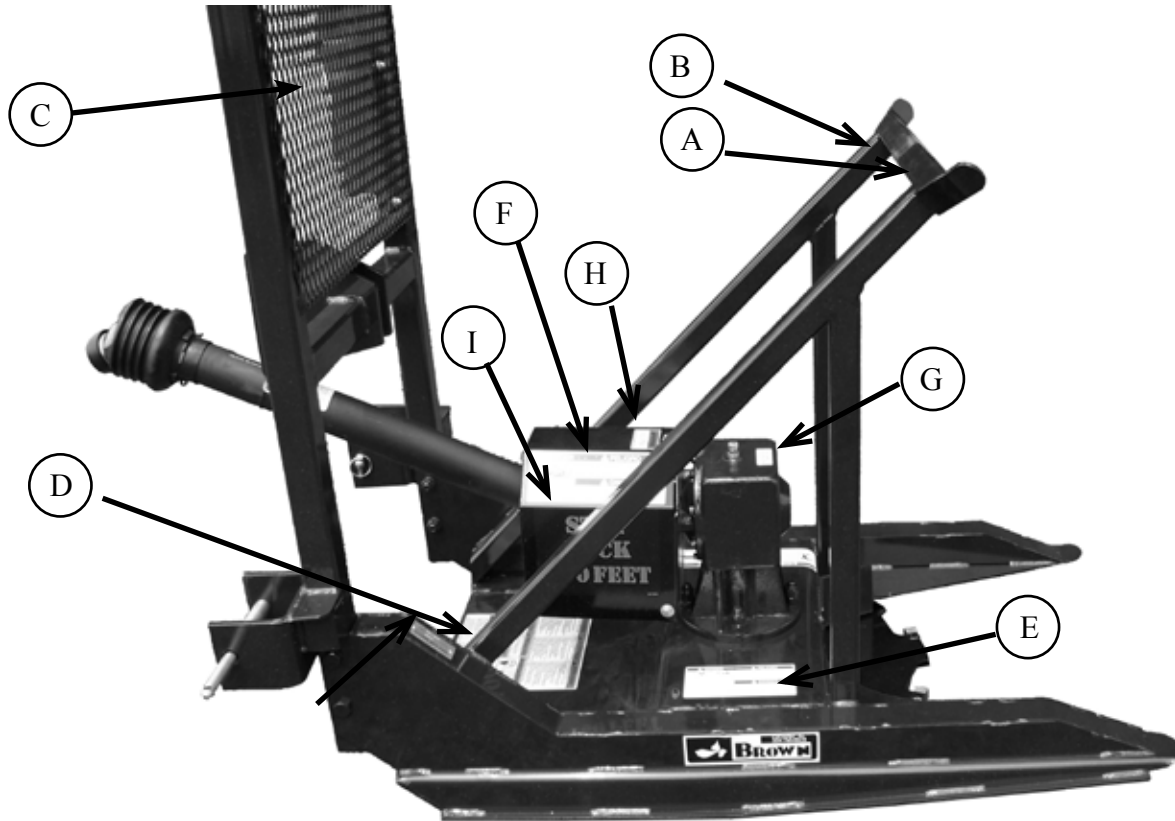

Ref. No.	Part No.	Qty	Description
A	SD-007A		Safety Decal: Operate at 540 RPM PTO.
B	SD-020		Safety Decal: Tighten blade bolts.
C	MH-01		Safety Manual Holder
D	SDL-020		Safety Decal: Multiple decals on one sheet - includes SD-101, SD002, SD-009A and SD-SW2
E	SD-005A	2	Safety Decal: Rotating blades.
F	SD-006A	3	Safety Decal: Rotating driveline.
G	SD-001A	2	Safety Decal: Thrown object hazard.
H	237-0009	1	Safety Decal: No step.
I	237-0020	2	Safety Decal: Stay Back 300 Feet
NP	DC-3-5-018		Safety Decal: Shield missing (placed on drive shaft, under shields).

# Equipment Safety

## **Warning! Transport with care.**

Before transporting to a new location, make certain that the slow-moving vehicle (SMV) emblem is installed and is clearly visible. Use flashing lights and follow local traffic regulations.

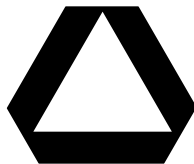

### **WARNING**

Transport with care. Use slow-moving vehicle emblem and flashing light. Follow local traffic regulations.

## **Danger! Protect bystanders, clear work area of debris.**

Do not operate the cutter near people. Debris can be thrown hundreds of feet. Clear work area of foreign objects such as wire, glass, and other debris. Debris thrown by the cutter can cause serious injury or death.



### **DANGER**

Do not operate cutter near bystanders. Clear work area of debris before operating.

## **Warning! Parking and dismounting.**

The rotating parts of this cutter continue to rotate even after the PTO has been disengaged. The operator should remain seated until rotation has stopped. He should then set the brake, turn off the engine, and remove the key. See tractor manual for proper parking procedure.



### **WARNING**

Wait for all rotation to stop before dismounting tractor.

## **Caution! Avoid fires.**

Keep the machine clean of debris, trash, and any other flammable material.



### **CAUTION**

Keep machine clean of debris. Flammable debris on machine poses fire hazard.

 **Warning!**  
Fasten Seatbelt!  
Before Starting Tractor!  
Always Wear Your Seatbelt.



# Equipment Safety

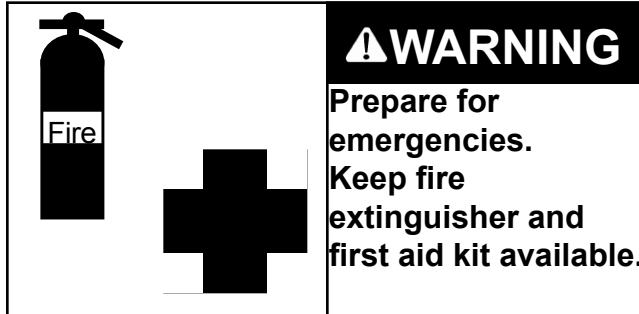

## ⚠️ Warning! Prepare for emergencies.

Keep fire extinguisher and first aid kit available. Inspect fire extinguisher and check for charge daily. Check first aid kit for expired contents and keep stocked.



## ⚠️ Warning! Check equipment before operating.

Tighten all nuts and bolts before operating. Make certain that equipment is lowered to ground before attempting to make adjustments or perform maintenance. Replace or repair any safety device, bolts, etc., if damaged or worn.



## ⚠️ Danger! Stay clear of rotating blades.

The TreeSaw is designed to cut trees and brush up to six inches in diameter. **Keep hands and feet away from blade!**

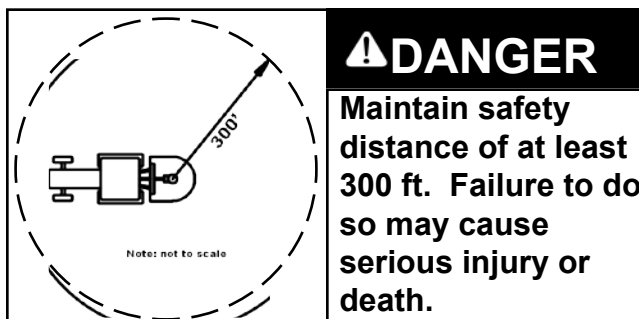

## ⚠️ Danger! Maintain safety distance.

The TreeSaw creates a serious discharge hazard. Always maintain a safety distance of at least 300 ft. **Never operate TreeSaw with bystanders present!**

# Equipment Safety

## **Warning! Wear protective clothing.**

Wear close-fitting clothing and other protective devices appropriate for the job.

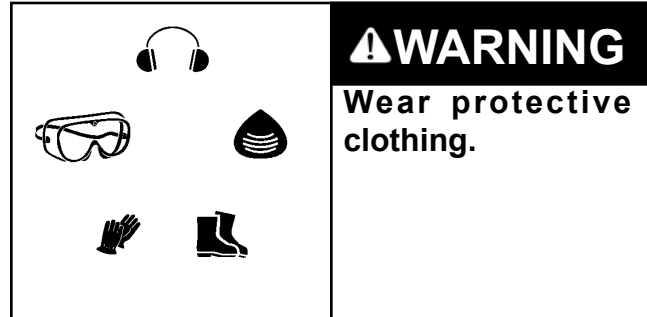

## **Warning! Roll-over protection.**

Do not operate the TreeSaw on any tractor not equipped with a certified roll-over protective structure (ROPS).

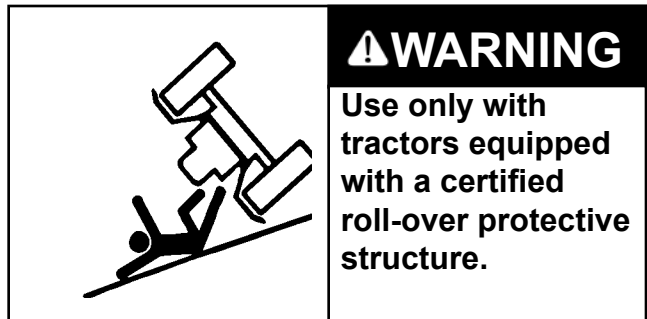

## **Warning! Slopes and rough terrain.**

When operating on slopes or rough terrain, decrease travel speed. Do not operate in an area where the tractor could roll over. **Be sure to fasten safety belt when operating tractor!**

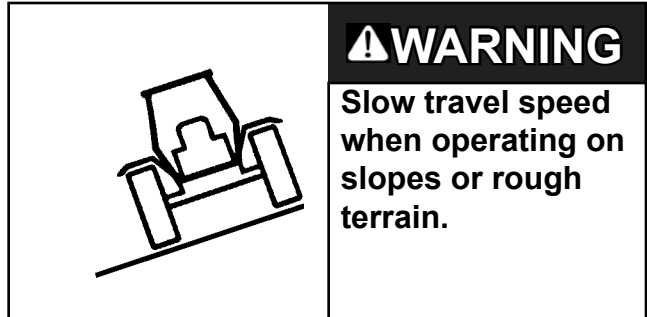

## **Danger! Tighten blade bolts.**

Blade bolts may loosen with use and must be tightened. Follow maintenance instructions in this manual (see page 23). **If the TreeSaw is operated with loose blade bolts, blade and blade carrier will be damaged. Operation with loose blade bolts, damaged blade or blade carrier will lead to blade ejection and will cause serious injury or death.**





# Equipment Safety



**⚠DANGER**  
Riders can be injured or killed. Keep riders off machine.

**⚠Danger! Keep riders off machine.**

Riders can be seriously injured or killed by entanglement or by falling.



**⚠DANGER**  
Stay clear of rotating drivelines. Keep driveline shields in place.

**⚠Danger! Stay clear of rotating drivelines.**

Entanglement in driveline can cause serious injury or death. Keep driveline shields in place at all times during operation. Driveline must turn freely inside shields. Driveline shields must be chained to prevent rotation.

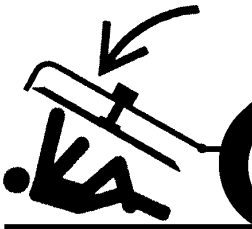

**⚠WARNING**  
Exercise caution while working under TreeSaw deck. Failure to heed warnings may lead to serious injury or death.

**⚠Warning! Hazardous service conditions.**

While working under the TreeSaw deck, be aware of safety hazards. Follow safety precautions specified in this manual (see page 22). Failure to exercise caution may lead to serious injury or death.

**DO NOT OPERATE THIS UNIT IF YOU ARE UNDER THE INFLUENCE OF ALCOHOL, ILLEGAL DRUGS, OR ANY PRESCRIPTION OR OVER THE COUNTER MEDICATIONS THAT COULD CAUSE DROWSINESS, DIZZINESS, DISORIENTATION AND/OR IMPAIR YOUR ABILITY IN ANY WAY TO SAFELY OPERATE THE UNIT.**

**DO NOT OPERATE THIS UNIT IF YOU SUFFER FROM ANY PHYSICAL CONDITON OR DISABILITY THAT WOULD IMPAIR YOUR ABILITY TO OPERATE IT SAFELY.**

# Notes

# Assembly

1. Separate the male and female halves of the drive shaft. Apply heavy grease to the telescoping portion of the male drive shaft; recouple the drive shaft.
2. Mount Bell shield bracket onto face plate of gear box with bolts provided, if not installed.
3. Remove both bolts from the clutch hub. Slide the hub onto the input shaft of the gearbox. Align the groove on the input shaft with the bolt holes on the hub. Reinstall the lock bolts and tighten securely. **Re-torque hub bolts on all models every hour for the first eight hours of use. Failure to do so will result in decreased life of the clutch hub and gearbox shaft splines.**
4. Mount Bell shield onto Bell shield bracket, covering the slip clutch. Using bolts provided.



**Warning!** The driveline shield and bell shield must be kept in good operating condition. Failure to maintain safety shields can result in injury or death.

5. Check the drive shaft for proper length:
  - a. Attach the TreeSaw to the tractor.
  - b. Lift the TreeSaw to the tractor's maximum lift position.
  - c. Measure the distance from the PTO of the tractor to the input shaft of the TreeSaw's gear box.
  - d. With the drive shaft compressed (pushed together fully), measure the overall length of the shaft.
  - e. If the length of the compressed drive shaft is greater than the length between the PTO and input shaft, then the drive shaft must be shortened to the latter length. **Please note that equal amounts must be removed from each section of the drive shaft.**
6. **Locate vent plug in owners manual storage tube. Remove shipping plug from top center of gearbox. Install vent plug into top port. Failure to install vent plug can and will cause seal failure.**
7. **For TSG-200: Install hydraulic hoses to cylinder, make sure part number 255-4100 (Flow Restrictor) is installed in either hose to control grapple movement. Install Quick Connectors (not provided) to tractor ends of hoses, attach tractor end of hoses to hydraulic remotes of your tractor.**

FOR ANY QUESTION ABOUT PROPER ASSEMBLY  
PLEASE CONTACT YOUR LOCAL DEALER OR CALL  
BROWN MFG. AT 1-800-633-8909

# Operation

Before hitching TreeSaw to your tractor, make sure all safety devices are installed on both the TreeSaw and the tractor.



Please follow all safety instructions and procedures.

## Attach Equipment to Tractor.

Be sure the tractor is equipped with the correct category hitch pins, top link, etc. Be extremely careful when positioning tractor to hitch to the equipment.



**Caution!** Never allow anyone between the tractor and the equipment during the hitching process.

Be certain that the TreeSaw has been lubricated properly and check oil level in gear box prior to connecting driveline to tractor, the oil should be at the lower edge of the side port of the gearbox.

Attach the driveline to the tractor. **When attaching driveline to PTO shaft, be certain that the TRACTOR ENGINE AND PTO OUTPUT SHAFT HAVE STOPPED - PARK BRAKES ARE SET BEFORE DRIVE SHAFT IS MOUNTED. Make sure quick-disconnect pin is properly seated in the groove of the tractor's PTO shaft.**



**Warning!** A loose driveline can disconnect and cause personal injury property damage or death.

## Adjust Cutting Height.



**Warning!** Be certain that tractor engine is stopped, park brakes are set, key is removed, and all rotation of the TreeSaw has ceased before dismounting to making adjustments.

Your Brown TreeSaw is designed to cut at ground level, however for optimum blade and tip life adjust to approximately 1" above ground level.

# Operation

## Starting TreeSaw

Power for operating the TreeSaw is supplied from the tractor PTO. Refer to your tractor manual for instructions on engaging and disengaging the PTO.

**Warning!** Do not operate this TreeSaw unless the tractor has a live, or independent, PTO. The momentum created by the blade carrier can push the tractor forward unexpectedly.

**Warning!** Operate TreeSaw only at the specified PTO RPM. Brown TreeSaws are designed to operate at 540 RPM; however, a 1000 RPM design is an option.

## Operating Speed

Proper operating speed for equipment will depend upon the height, density, and type of the material to be cut. Regardless of chosen ground speed, always operate the PTO at the recommended RPM when cutting.

## General Operation

**Warning!** Avoid personal injury or death. Walk the area before operation begins. Remove or flag all rocks and any other hazardous debris from site.

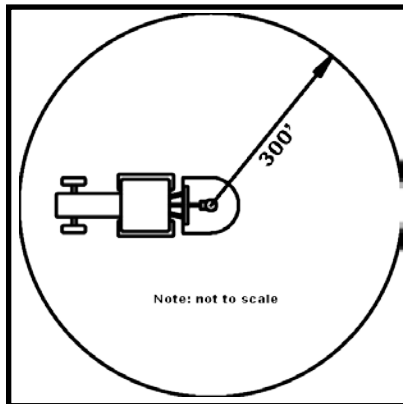

Observe the following guidelines when operating the TreeSaw:

- Never lower the TreeSaw onto material.
- Avoid tight turns near trees or other objects. The deck may be damaged by side impact.

**Remember:** The safe operation of this equipment is the responsibility of the operator. The operator should be familiar with both the tractor and the equipment. The operator must read and understand all applicable operator manuals and follow all safety practices.

**Warning!** Avoid personal injury or death. Never operate machine around bystanders. Always maintain a distance of at least 300 feet.

DO NOT OPERATE THIS UNIT IF YOU ARE UNDER THE INFLUENCE OF ALCOHOL, ILLEGAL DRUGS, OR ANY PRESCRIPTION OR OVER THE COUNTER MEDICATIONS THAT COULD CAUSE DROWSINESS, DIZZINESS, DISORIENTATION AND/OR IMPAIR YOUR ABILITY IN ANY WAY TO SAFELY OPERATE THE UNIT.

DO NOT OPERATE THIS UNIT IF YOU SUFFER FROM ANY PHYSICAL CONDITON OR DISABILITY THAT WOULD IMPAIR YOUR ABILITY TO OPERATE IT SAFELY.

# Maintenance

## Safety When Working Under TreeSaw

Never work under the TreeSaw deck until:

- The TreeSaw is sufficiently braced and supported
- The tractor engine is off, brake is set, and key is removed
- PTO has been disengaged
- Driveline is disconnected
- Rear tractor tires have been secured with tire chocks
- The TreeSaw has cooled



**Danger!** Failure to follow these safety guidelines will result in serious injury or death.

## Initial Maintenance



**Warning!** These maintenance practices must be followed every hour for the first eight hours of operation; the practices must also be performed every hour for the first eight hours following the removal/replacement of any of the components named in this section. Check daily thereafter.

1. Tighten the clutch hub clamp bolts holding the slip clutch to the input shaft of the gearbox.



**Caution!** Failure to tighten the clamp bolts will shorten the life of the slip clutch hub.

2. Check for debris deposited between the blade and the deck. Debris found jamming or locking the blade must be removed.

3. Tighten blade bolts and blade bar nut.



**Warning!** Failure to tighten blade tip screws and blade bar nut can cause blade tips, blade tip screws, blade, or output shaft to break, which can result in injury or death.

4. Check for debris deposited around the output shaft.

5. Tighten gearbox mounting bolts.



**Caution!** Failure to keep the gearbox bolts tightened can cause the blade to strike the bottom of the TreeSaw deck or break the output shaft of the gearbox.

# Maintenance

## Daily Maintenance

1. Repeat all steps listed under the “Initial Maintenance” section on a daily basis after the initial maintenance has been performed.
2. Lubricate the driveshaft tubes and U-joint.
3. Check and maintain the proper amount of lubricant in the gearbox. **The recommended lubricant for the gearbox is cotton picker spindle lubricant (part # 235-0031).**
4. Check the blade and blade tips; sharpen or replace blade tips as necessary.

 **Warning!** Use only blades and blade tips supplied by Brown Manufacturing Corporation. Failure to do so will void all warranty and can cause injury or death. Only Brown has access to the engineering and test data necessary to produce a high-quality blade that meets all safety and quality requirements.

## Tightening Carbide Tip Bolts

Inspect carbide tip screws each hour for the first eight hours of use for proper torque. **Repeat hourly inspections each time the carbide tips are removed/replaced.**

1. Disengage PTO; be certain that all rotation has stopped.
2. Lift TreeSaw high enough to place suitable supports under the TreeSaw deck.
3. Turn tractor engine off; remove key; lock transmission and brakes; chock rear wheels.
4. Disconnect driveline.
- 5.

 **Warning!** Failure to keep blade carrier bolts tight can and will cause: blade breakage; warping of blade bar; and/or ejection of blade from TreeSaw. These hazards can cause serious injury or death.

 **Warning!** If blade bolts are allowed to run loose, the obvious danger is for the bolts to come out, allowing the blade to be ejected from the TreeSaw.

 **The described occurrences will cause the blade to break and be ejected. An ejected blade can and will cause serious injury or death.**

# Maintenance

## Tightening Output Shaft Nut:

Remove blade bar cotter pin and tighten nut with a 1½” socket. Torque nut to 300 ft./lbs.; continue to torque until cotter pin hole aligns with nut. Install a new cotter pin. **Never loosen nut to align cotter pin hole; always tighten to next alignment slot. When replacing blade check hub for wear, clean thoroughly and apply anti-seize to shaft before assembly.**

## Proper Gearbox Lubrication

On level ground, remove the pipe plug from the right side of the gearbox housing. If the oil level is not at that port level, oil must be added. Remove the vent plug from the top of the housing and add the recommended lubricant (cotton picker spindle grease) until the oil level reaches the side port. **Make certain both plugs are replaced and tightened securely before operating.**



## THE TEN COMMANDMENTS OF OPERATION

1. **ALWAYS** - Read and understand the owners manual before operating this or any other equipment.
2. **ALWAYS** – Attach this product to a tractor that has suitable safety equipment properly installed .
3. **ALWAYS** – Operate this equipment with all safety equipment properly installed on this equipment.
4. **ALWAYS** – Start the cutting process by inspecting, walking, flagging or removing all foreign material from job site.
5. **ALWAYS** – Do NOT allow riders or bystanders within 300 feet of this unit during operation.
6. **ALWAYS** – Check all bolts, fasteners, fittings and oil levels before operating this equipment.
7. **NEVER** – Allow blades to make contact with rocks, – unit was not designed for this type of operation.
8. **NEVER** – Allow an untrained operator to operate this equipment.
9. **ALWAYS** – Install genuine Brown replacement parts, all other replacement parts will void warranty.
10. **ALWAYS** – REMAIN on tractor seat until blades have stopped turning and all tractor shut down procedures have been completed.

**THESE ARE ONLY A FEW OF THE SAFETY PROCEDURES THAT MUST BE FOLLOWED TO INSURE THE SAFE OPERATION OF THIS EQUIPMENT – MANY OTHER SAFETY RELATED POINTS ARE STATED THROUGHOUT THIS MANUAL**



**WARNING: FAILURE TO FOLLOW THE TEN COMMANDMENTS CAN AND WILL CAUSE SERIOUS INJURY OR DEATH**

**IF YOU HAVE ANY SAFETY, MAINTENANCE OR OPERATIONAL QUESTIONS – PLEASE CALL BROWN MFG. BEFORE USING THIS EQUIPMENT AT 1-800-633-8909**



# Notes

# Troubleshooting

<b>Problem</b>	<b>Possible Cause(s)</b>	<b>Possible Solution(s)</b>
Excessive vibration	<ol style="list-style-type: none"> <li>1. Loose gearbox bolts</li> <li>2. Loose blade hub</li> <li>3. Blade not freely spinning</li> <li>4. Broken, bent, or warped blade</li> <li>5. Blade hub not seated properly on shaft</li> </ol>	<ol style="list-style-type: none"> <li>1. Tighten bolts</li> <li>2. Tighten blade hub nut or blade bolts</li> <li>3. Clear blade of obstruction or replace blade.</li> <li>4. Replace blade</li> <li>5. Remove blade; clean hub and shaft; lubricate with anti-sieze, reseal</li> </ol>
Excessive clutch slippage	<ol style="list-style-type: none"> <li>1. Worn clutch linings or plates</li> <li>2. Oil on lining</li> <li>3. Glazed friction lining</li> <li>4. Excessive force on clutch</li> <li>5. Dull Blade Tips</li> </ol>	<ol style="list-style-type: none"> <li>1. Repair clutch</li> <li>2. Replace linings</li> <li>3. Clean with emery cloth</li> <li>4. Reduce ground speed, material intake, or tractor size</li> <li>5. Replace carbide tips</li> </ol>
Overheating gear-box	<ol style="list-style-type: none"> <li>1. Insufficient lubricant level</li> <li>2. Improper lubricant</li> <li>3. Debris build-up around gearbox</li> <li>4. Bearing or gears set improper</li> </ol>	<ol style="list-style-type: none"> <li>1. Fill to full level</li> <li>2. Replace with correct lubricant</li> <li>3. Remove debris</li> <li>4. Consult dealer</li> </ol>
Noisy gearbox	<ol style="list-style-type: none"> <li>1. Rough gears</li> <li>2. Worn bearings</li> <li>3. Insufficient lube level</li> </ol>	<ol style="list-style-type: none"> <li>1. Run for a short break-in period or replace gears</li> <li>2. Replace bearing</li> <li>3. Add lube.</li> </ol>
Leaking gearbox	<ol style="list-style-type: none"> <li>1. Damaged oil seal</li> <li>2. Bent shaft</li> <li>3. Oil seal installed incorrectly</li> <li>4. Oil level too high</li> <li>5. Shaft rough or pitted in oil seal area</li> <li>6. Shaft bore worn in casting</li> <li>7. Damaged gasket</li> <li>8. Loose bolts</li> </ol>	<ol style="list-style-type: none"> <li>1. Replace seal</li> <li>2. Replace seal and shaft</li> <li>3. Replace seal</li> <li>4. Drain oil to proper level</li> <li>5. Replace shaft</li> <li>6. Replace casting or gearbox</li> <li>7. Replace gasket</li> <li>8. Tighten bolts.</li> </ol>
Short carbide life	<ol style="list-style-type: none"> <li>1. Cutting too low</li> <li>2. Cutting in sandy or rocky conditions</li> <li>3. Inadequate carbide tips</li> <li>4. Ground speed too fast</li> </ol>	<ol style="list-style-type: none"> <li>1. Increase cutting height</li> <li>2. Increase cutting height</li> <li>3. Replace with Brown carbide tips</li> <li>4. Slow ground speed</li> </ol>
Not cutting clean	<ol style="list-style-type: none"> <li>1. Dull carbide tips</li> <li>2. Insufficient PTO speed</li> <li>3. TreeSaw not level</li> <li>4. Ground speed too fast</li> <li>5. Blade not spinning freely</li> <li>6. Low engine RPM</li> </ol>	<ol style="list-style-type: none"> <li>1. Sharpen and balance or replace blade tips</li> <li>2. Use correct PTO speed</li> <li>3. Adjust TreeSaw</li> <li>4. Reduce ground speed</li> <li>5. Clear blade of obstruction</li> <li>6. Maintain tractor RPM to correct PTO speed</li> </ol>

# Specifications

Model	Gearbox	Cutting Width	Driveshaft Size Cat.	Weight	Slip Clutch	Hitch
TS-100	235-0001	36"	6	850 lbs.	2-disc	Category I/II
TSG-200	235-0001	36"	6	1,050 lbs.	2-disc	Category I/II

Standard Features
All welded, 7 ga. (3/16") steel frame
Quick Hitch Compatible, clevis style 3-point hitch
0" to 12" cut height
1 : 1.46 gear ratio

# Replacement Parts TS-100

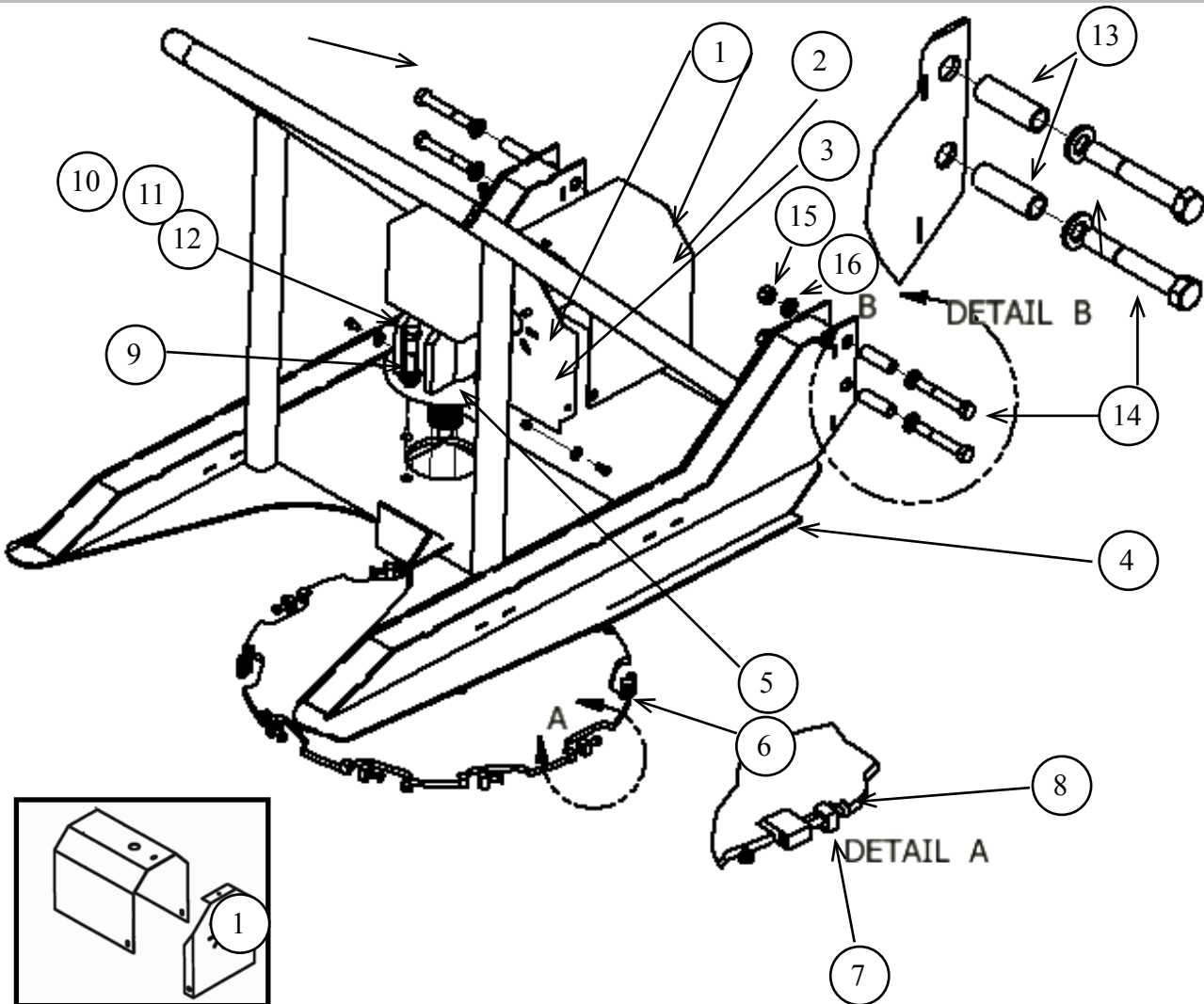

Ref. No.	Part No.	Qty	Description
1	232-0028	1	Bell Shield Assembly (Consists of (1) 700-232-0031 and (1) 700-232-0030) w/ 3 each, HC56C16Z 3/8" x 1" Gr 5 Bolt Zinc, WUS38Z 3/8" USS Flat Washer Zinc and LOC38Z 3/8" Lock Washer Zinc
2	700-232-0031	1	Drive Shaft Guard
3	700-232-0030	1	Plate, Drive Shaft Guard
4	260-0010	1	TS-100 Frame
5	235-0001	1	120 HP Gearbox
6	260-0525	1	Blade, 36" With Carbide Tips - Through Hole Design
7	255-1590	12	Carbide Tip, Flat Bottom
8	HS865C24 NNF85CZ	12 12	Hex Socket Shoulder Bolt Grade 8 - 3/8" x 1 1/2" NC Nylock Flange Nut Grade 8 - 5/16 NC
NP	HC56C16Z	3	Bell Shield Attaching Bolt 3/8-16 x 1" HCS Gr5

# Replacement Parts

## Skid Assembly (continued)

Ref. No.	Part No.	Qty	Description
9	HC812F52Z	4	Bolt, 3/4-16 x 3 1/4 NF Grade 8 Zinc
10	HN834FZ	4	Nut, Hex 3/4-16 Grade 8 Zinc
11	NNE834FZ	4	Nut, Nylon Lock 3/4-16 Grade 8 Zinc
12	WSA834Z	4	Washer, Flat SAE 3/4 Grade 8 Zinc
13	700-260-0227	4	Hitch Bushing
14	HC512C72Z	4	Bolt, 3/4 x 4 1/2" HCS Gr 5
15	NNE34CZ	4	Nulon Lock Nut, 3/4-10 Zinc NC
16	WUS34Z	4	Flat Washer USS 3/4" Zinc
17	260-0090	1	Blade Hub
18	HC88C32Z	4	Blade Hub Bolt 1/2-13 x 2" Gr8 Zinc
19	260-0600	1	Bottom Wear Plate
20	HC88C24Z	2	Wear Plate Bolt 1/2-13 x 2" Gr8 Zinc

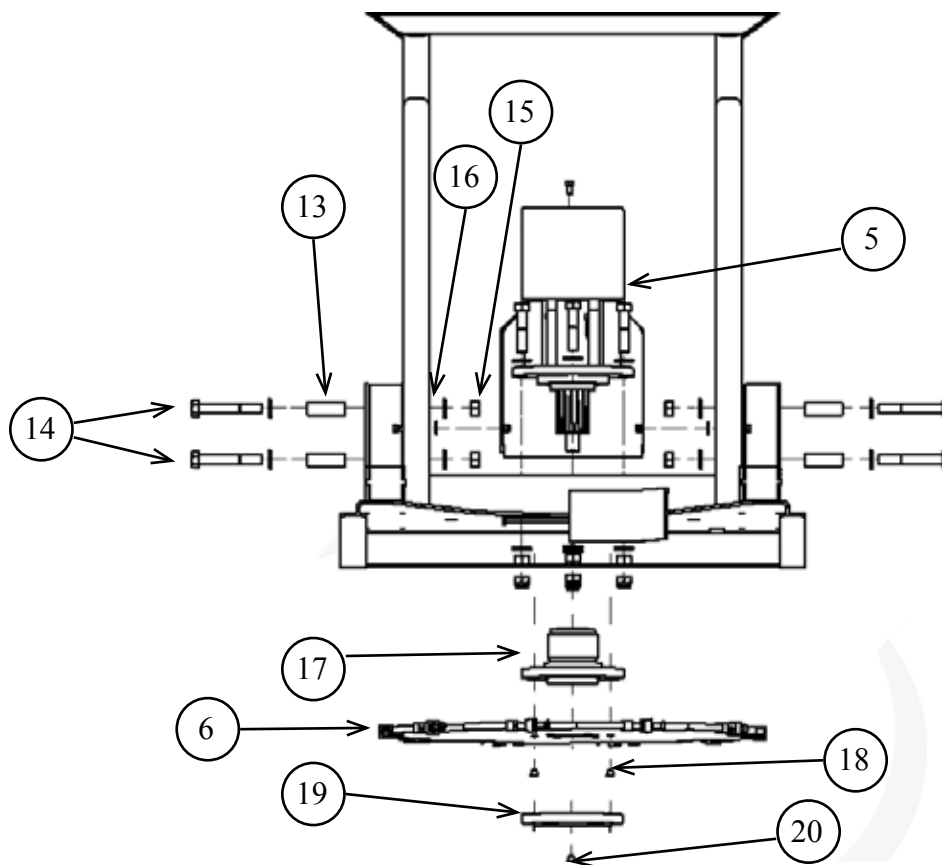

# Replacement Parts TSG-200

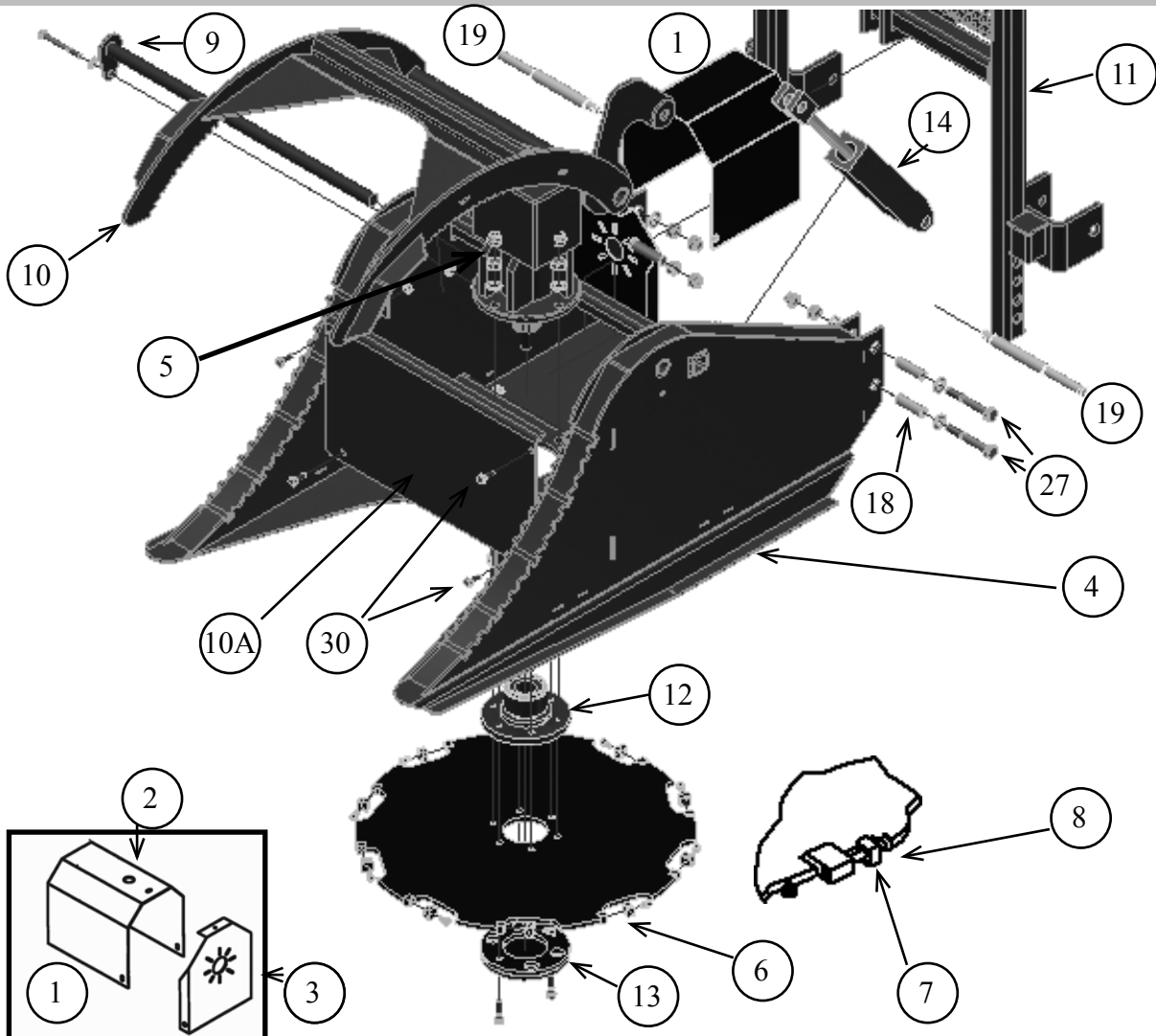

Ref. No.	Part No.	Qty	Description
1	232-0028	1	Bell Shield Assembly (Consists of (1) 700-232-0031 and (1) 700-232-0030) w/ 3 each, HC56C16Z 3/8" x 1" Gr 5 Bolt Zinc, WUS38Z 3/8" USS Flat Washer Zinc and LOC38Z 3/8" Lock Washer Zinc
2	700-232-0031	1	Drive Shaft Guard
3	700-232-0030-2	1	Plate, Drive Shaft Guard - Mod
4	260-0200	1	TSG-200 Frame
5	235-0001	1	120 HP Gearbox 540 RPM 1:1.46
6	260-0525	1	Blade, 36" With Carbide Tips - Through Hole Design
7	255-1590	12	Carbide Tip, Flat Bottom
8	HS865C24 NNF85CZ	12 12	Hex Socket Shoulder Bolt Grade 8 - 3/8" x 1 1/2" NC Nylock Flange Nut Grade 8 - 5/16 NC
9	260-0300	1	Grapple Attaching Shaft
10	260-0100	1	Grapple
10A	700-260-2330	1	Bash Plate



# Replacement Parts TSG-200

Ref. No.	Part No.	Qty	Description
11	260-0150	1	3 Point Hitch w/ Limb Guard
12	260-0090	1	Blade Hub
13	260-0600	1	Bottom Wear Plate
14	TC2-001	1	Grapple Cylinder 2" x 10" TRE 3/8 FPT
15	255-4100	1	Hydraulic Flow Restrictor
16	255-3878	1	Hose Assembly 3/8" x 78"
17	255-3890	1	Hose Assembly 3/8" x 90"
18	700-260-0227	4	Hitch Bushing
19	255-1200	2	CAT I/II Pin, Quick Hitch Double End
20	500-22	1	Top Link Hitch Pin CAT II (Not Pictured)
21	HC812F52Z	4	Hex Bolt 3/4" 16 x 3 1/4" NF Gr 8 Zinc (Gearbox Bolts)
22	HN834FZ	4	Hex Nut 3/4" 16 NF Gr 8 Zinc (Gearbox)
23	NNE834FZ	4	Nylon Lock Nut 3/4" 16 NF Gr 8 Zinc (Gearbox)
24	WSA834Z	8	Flat Washer SAE 3/4" Gr 8 Zinc
25	HC88C32Z	4	Hex Bolt 1/2" 13 x 1 1/2" NC Gr 8 Zinc (Blade Bolts)

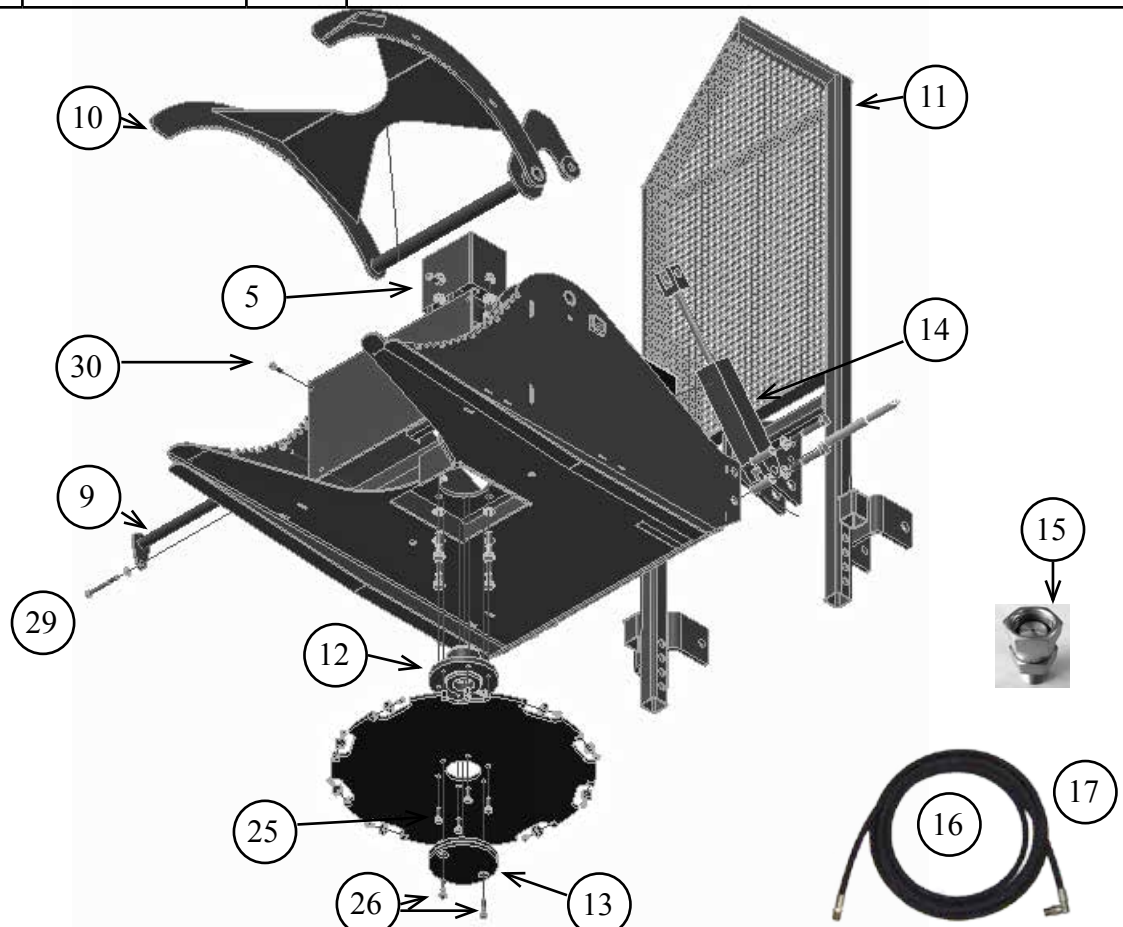

Bolt Listing continued on Page 35

# Replacement Parts TPH

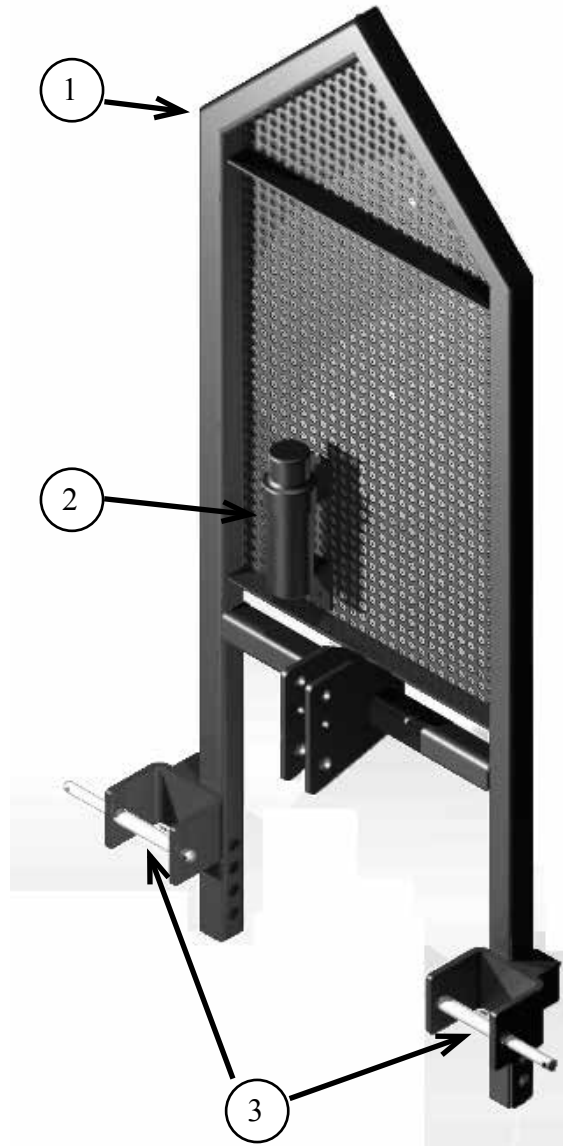

Ref. No.	Part No.	Qty	Description
1	260-0150	1	Three Point Hitch w. Brush Guard Quick Hitch Compatible
2	255-1200	2	Cat I/II Quick Hitch Double End Pin
3	MH-01	1	Manual Holder
NP	TC-126A	3	Lynch Pin 7/16"
NP	500-22	1	Cat II Top Link Pin
NP	CB5516C12Z	2	Manual Holder Attaching Bolt 5/16-18x3/4" Gr5 USS Zinc Carriage Head Bolt
NP	NNE516C12Z	2	Manual Holder Attaching Nut Nulon Lock 5/16-18 Zinc
NP	WUS516Z	2	Manual Holder Attaching Washer Flat USS 5/16 Zinc

# Bolt List (Continued from page 33)

Ref. No.	Part No.	Qty	Description
26	HC88C32Z	2	Hex Bolt, 1/2-13 x 2 NC Grade 8 Zinc (Wear Plate Bolts)
27	HC512C72Z	4	Hex Bolt, 3/4-10 x 4 1/2" NC Grade 5 Zinc (Limb Guard Bolts)
28	WUS34Z	8	Flat Washer USS 3/4" Zinc (For Limb Guard Bolts)
29	HC58C64Z	1	Hex Bolt, 1/2" 13 x 4" HCS Gr 5 Zinc (Grapple Shaft)
30	HC58C16Z	4	Hex Bolt, 1/2" 13 x 1" HCS Gr 5 Zinc (Bash Plate Bolts)
NP	HN550CZ	5	Hex Nut 1/2" 13 Gr 5 Zinc
NP	WUS50Z	2	Flat Washer USS 1/2" Zinc

# Replacement Parts

## 130HP Gearbox

**NOTE: Gearbox for all TreeSaws**

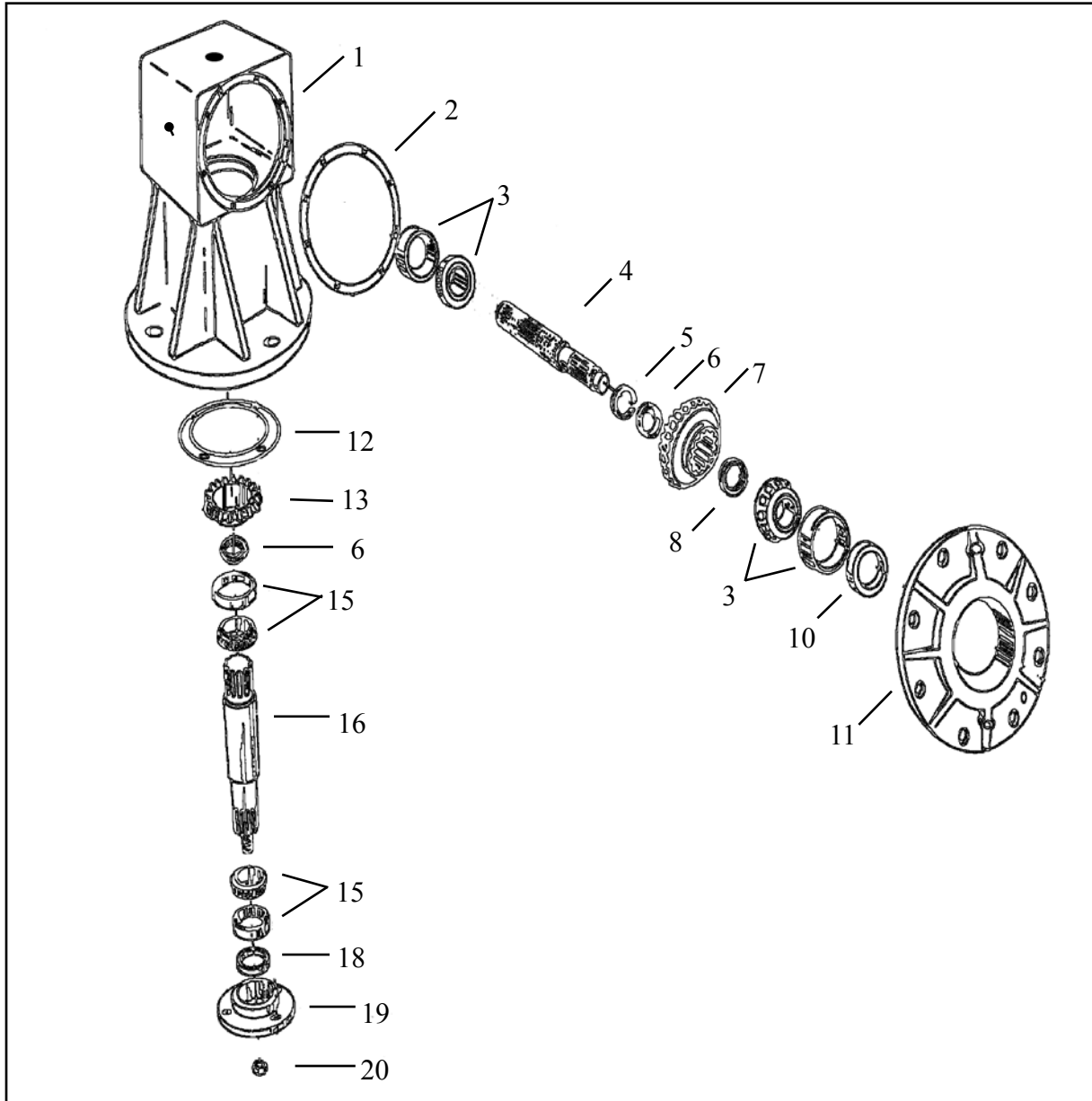

### Ordering replacement parts

Please contact the nearest Brown dealer for replacement parts. Or call Brown Mfg. at 800-633-8909 for parts or technical information. Please have model and serial number available when ordering parts.

# Replacement Parts

## 130HP Gearbox (*continued*)

Ref. No.	Part No.	Qty.	Description
1	235-0003	1	Housing
2	235-0105	1	Input Cap Gasket Kit
3	235-0018	2	Bearing Assembly, Input
4	235-0005	1	Input Shaft
5	235-0019	1	Retaining Ring
6	235-0110	1	Shim Kit
7	235-0007	1	19 Tooth Gear, Input
8	235-0006	2	Spacer
10	WHD-202-20	1	Input Oil Seal
11	235-0004	1	Input Cap
12	235-0100	1	Output Cap Gasket Kit
13	235-0017	1	13 Tooth Gear, Output
15	235-0016	2	Bearing Assembly, Output
16	235-0015	1	Output Shaft
18	235-0013	1	Output Oil Seal
19	235-0014	1	Output Cap
20	TC-134F	1	1" - 14 Flanged Hex Nut
NP	TC-135	1	Cotter Pin
NP	235-0001	1	130 HP Gearbox Assembly Complete 540 RPM
NP	235-0022	1	Vent Plug
NP	235-0021	2	Drain Plug
NP	235-0031	2 QT.	Lubricant, Quart, Cotton Picker Spindle

# Replacement Parts (Driveline)

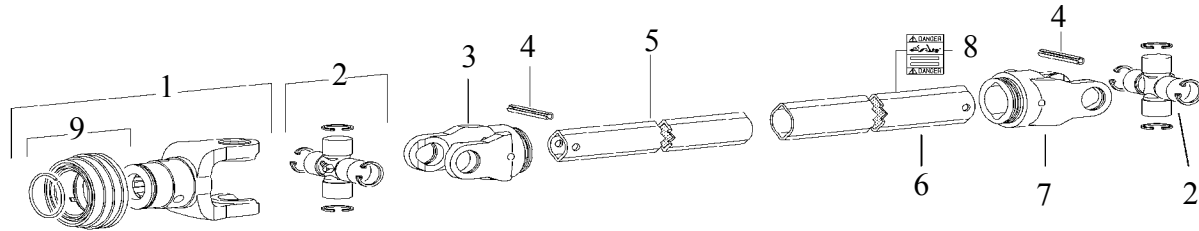

Ref. No.	Part No.	Description
1	236-4002	Quick-disconnect yoke
2	236-4004	U-joint kit
3	236-2224	Inner tube yoke
4	236-1070	Roll key
5	236-1737 236-1837	415 - 416, Inner tube 417, Inner tube
6	236-1739 236-1839	415 - 416, Outer tube 417, Outer tube
7	236-2230	Outer tube yoke
8	236-1745	Decal, missing shield
9	236-1731	Quick-disconnect kit
Not pictured	236-4000	Complete drive shaft with 2-disc slip clutch and shield

## Driveline Safety Shield

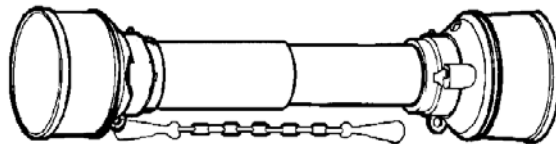

Part No.	Description
236-1725	Complete shield assembly

# Replacement Parts

## 2-Disc Slip Clutch

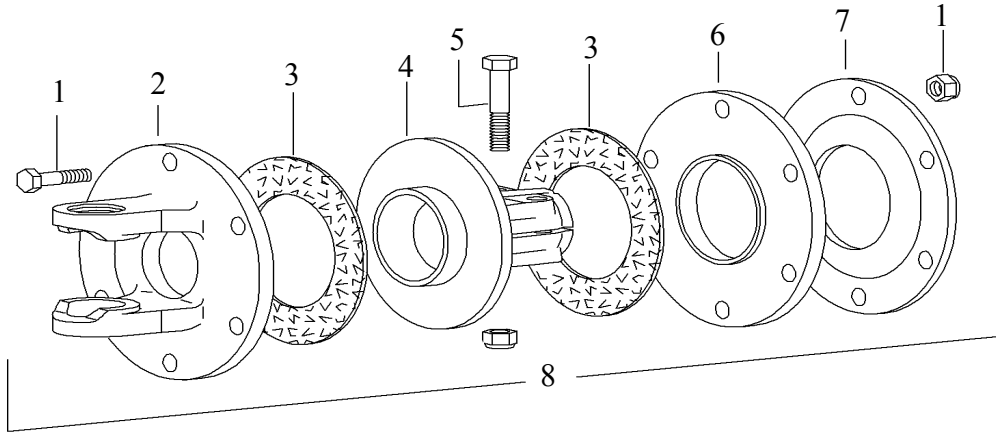

Ref. No.	Part No.	Description
1	255-0400	Bolt, Clutch Tension M10 x 50 (6 Req.)
1a	255-0660	Lock Nut, Clutch Tension M10 (6 Req.)
2	236-2214	Yoke, flanged, 2 disc
3	236-1703	Lining, clutch, 2 req.
4	236-2212	Hub, 2 disc, 1-3/4" z 20
5	255-0420	Bolt, Hub Clamp M12 x 65 (2 Req.)
5a	255-0680	Lock Nut, Hub Clamp M12 (2 Req.)
6	236-1705	Plate, thrust, 2 disc
7	236-1706	Spring, belleville, 2 disc
8	236-2210	Clutch assembly, 2 disc

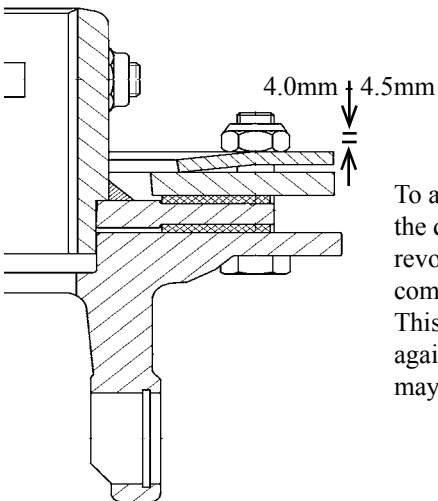

### CLUTCH ADJUSTMENT PROCEDURE 2-DISC SLIP CLUTCH

To adjust the clutch to proper torque, the gap between the belleville spring and the drive plate should be between 4.0-mm and 4.5mm. Tightening the nut one revolution will compress the spring 1.5-mm. Tightening the nut one flat side will compress the spring 0.25mm.

This can also be set by tightening each of the lock nuts until the spring is flat against the drive plate and then loosening each nut 3 full revolutions. The clutch may be adjusted by using two (2) 17-mm wrenches.

For use with the following starting serial numbers:

Model	Serial Number
TS-100	3XXX
TSG-200	3XXX

Version 3000.2.1  
May 2015



6001 E. Hwy 27 - Ozark, AL 36360  
334.795.6603 - Fax: 334.795.3029