



MASCHIO GASPARDO S.p.A.



FIORE

OPERATOR'S MANUAL - PARTS BOOK

SICKLE BAR MOWER

Cod. G19503950 2014-01





TABLE OF CONTENTS

Description		Operating	
Description of the sickle bar mower.....	5	How to choose between sickle bars	30
Assembly drawing	6		
Technical specification		Service Machine Safely	
Technical specification.....	7	Practice safe maintenance	31
Handling	7	Wear appropriate clothing	31
		Stay clear of rotating drivelines	31
Safety lables		Maintenance	31
Safety-Alert lables	8	Hazard bar	32
Identification machine.....	8		
Machine safety labels	8	Service	
Machine safety lables and position		Lubrification	33
Machine safety lables and position.....	9	Routine maintenance.....	33
		Every 2 work hours.....	33
Preparing the tractor		Wear-proof skids (optional)	33
Preparing the tractor.....	10	Every 8 work hours.....	33
Parking instruction	10	Every 50 work hours.....	33
Stay clear of rotating drivelines	10	Periodically (6 months)	34
		After each mowing	34
Installing		Cleaning and oiling the sickle bar.....	35
Installing sickle bar mower on tractor	10	Storage	35
PTO shaft adaptation.....	12	Checking the clearance tolerance	36
Stability of sickle bar and tractor during		Extra maintenance.....	38
transport	13	Replacement of section-holding bar	38
Parking instruction	14	Replacement of sections	38
Stay clear of rotating drivelines	14	Replacement of tooth-holding bar (riveted)	39
		Replacement of tooth (riveted)	39
Removing		Replacement of bar holding removable tooth	39
Removing sickle bar mower	15	Replacement of removable tooth.....	39
		Replacing the anti-vibration yokes.....	40
Operating		Replacement of belts.....	40
Operate safely	16	Replacement of pulleys	40
Wear appropriate clothing	17		
Stay clear of rotating drivelines	17	Transport on road	
		Transport on road	41
Operating - Mechanical Lifting System			
Use of Mechanical lifting system	18	Demolition and disposal	
Adapting the sickle bar mower	18	Demolition and disposal	42
Adjustment	18		
Mowing	20	Assembly	
		Assembly	43
Operating - Hydraulic Lifting System			
Use of Hydraulic lifting system	22	Spare parts	
Adapting the sickle bar mower	24	Spare parts	51
Adjustment.....	25		
Using the lifting device.....	26	Warranty	
Operation of lifting device	26	Warranty	68
Mowing on flat ground	27	Warranty for replacement parts	69
Mowing on slopes.....	28		
Operating - Quick Coupler			
Quick Coupler.....	29		
Removing sickle bar mower with			
Quick Coupler.....	29		

TO THE DEALER:

Assembly and proper installation of this product is the responsibility of the MASCHIO GASPARDO dealer. Read manual instruction and safety rules. Make sure all items on the Dealer's Pre-Delivery Check List in the Operator's Manual are completed before releasing equipment to the owner.

The dealer must complete the Warranty Registration, located on the MASCHIO GASPARDO website. **Warranty claims will be denied if the Warranty Registration has not been completed.**

TO THE OWNER:

Read this manual before operating your frontier equipment. The information presented will prepare you to do a better and a safer job. Keep this manual handy for ready reference. Require all operators to read this manual carefully and become acquainted with all the adjustment and operating procedures before attempting to operate. Replacement manuals can be obtained from your selling dealer.

The equipment you have purchased has been carefully engineered and manufactured to provide dependable and satisfactory use. Like all mechanical products, it will require cleaning and upkeep. Lubricate the unit as specified. Observe all safety information in this manual and safety decals on the equipment.

For service, your authorized MASCHIO GASPARDO dealer has trained mechanics, genuine MASCHIO GASPARDO service parts, and the necessary tools and equipment to handle all your needs.

Use only genuine MASCHIO GASPARDO service parts. Substitute parts will void the warranty and may not meet standards required for safe and satisfactory operation. Record the model number and serial number of your equipment in the spaces provided:

Model: _____ **Date of Purchase** _____

Serial Number: (see Safety Decal section for location) _____

Provide this information to your dealer to obtain correct repair parts.

Throughout this manual, the term **IMPORTANT** is used to indicate that failure to observe can cause damage to equipment. The terms **CAUTION**, **WARNING** and **DANGER** are used in conjunction with the Safety-Alert Symbol, (a triangle with an exclamation mark), to indicate the degree of hazard for items of personal safety.

! This Safety-Alert Symbol indicates a hazard and means **ATTENTION! BECOME ALERT! YOUR SAFETY IS INVOLVED!**



Indicates an imminently hazardous situation that, if not avoided, will result in death or serious injury.



Indicates a potentially hazardous situation that, if not avoided, could result in death or serious injury, and includes hazards that are exposed when guards are removed.



Indicates a potentially hazardous situation that, if not avoided, may result in minor or moderate injury.

IMPORTANT

Indicates that a failure to observe can cause damage to equipment.

NOTE

Indicates helpful information.

DESCRIPTION

Description of the sickle bar mower

This agricultural implement can only operate by means of a cardan shaft applied to the pto of an agricultural tractor equipped with lift and universal three-point hitch. Since it is movable, the mowing machine can be easily mounted on tractors with different gauges or on tracked vehicles (Fig. 1). The two-motion tooth-blade system used in mowing machines, makes possible a scissors cut which leads to a high speed operation on any crop. The original tooth-blade motion guarantees a sharp and clean cut on any type of grass, be it damp or flattened. It is thanks to the total absence of soil which this mowing system does not raise, sharp because the stems are not frayed. The sickle bar may also be used with the cutting arm tilted for working on canals, ditches and embankments (Fig. 2 and 3).

 **ATTENTION**
The sickle bar is suitable only for the uses indicated. Any other use different from that described in these instructions could cause damage to the machine and represent a serious hazard for the user.

It is therefore advisable to strictly comply with the following instructions in order to prevent faults which could jeopardize the correct and long-lasting operation of the implement. Compliance with the instructions in this handbook is also important since **the Manufacturer declines all and every responsibility for damage to persons or property caused by negligence and failure to comply with these instructions.**

The Manufacturer shall, however, remain at the customers' disposal for immediate and thorough assistance together with anything else that may be required in order to ensure the correct operation and maximum efficiency of the implement.

The Manufacturer reserves the right to make any modifications and improvements to the implement as may be considered opportune, without being obliged to immediately inform the user.

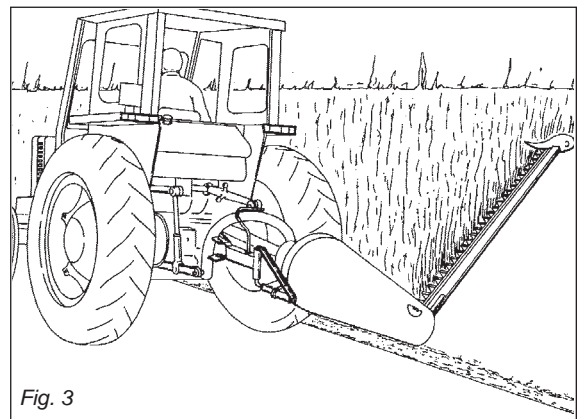
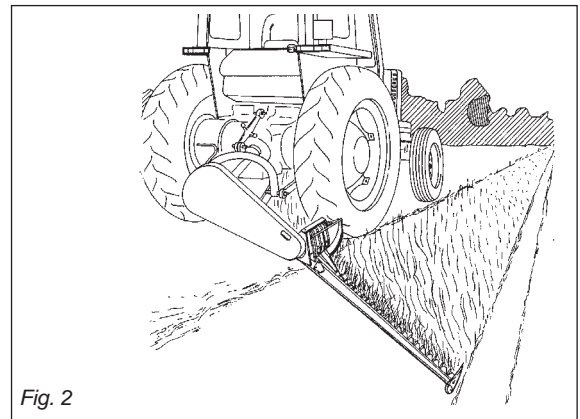
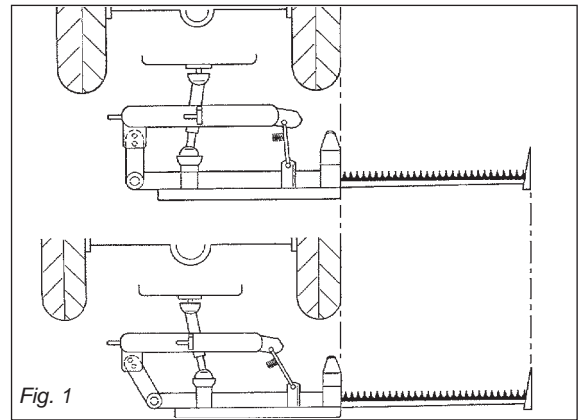

DESCRIPTION

Assembly drawing

- 1 External shoe;
- 2 Mowing guide;
- 3 Cutting arm;
- 4 Upper 3rd point hitches;
- 5 Gauge varying articulation;
- 6 Chassis;
- 7 Tirant;
- 8 Lower 3rd point hitches;
- 9 Hazard bar;
- 10 Support;
- 11 Identification label;
- 12 Cover;
- 13 Protective casing for connecting-rod systems;
- 14 Support;
- 15 Hinge (pivot point);
- 16 Blade guard;
- 17 PTO;
- 18 Lift link adjuster chain;
- 19 Hoisting arm.

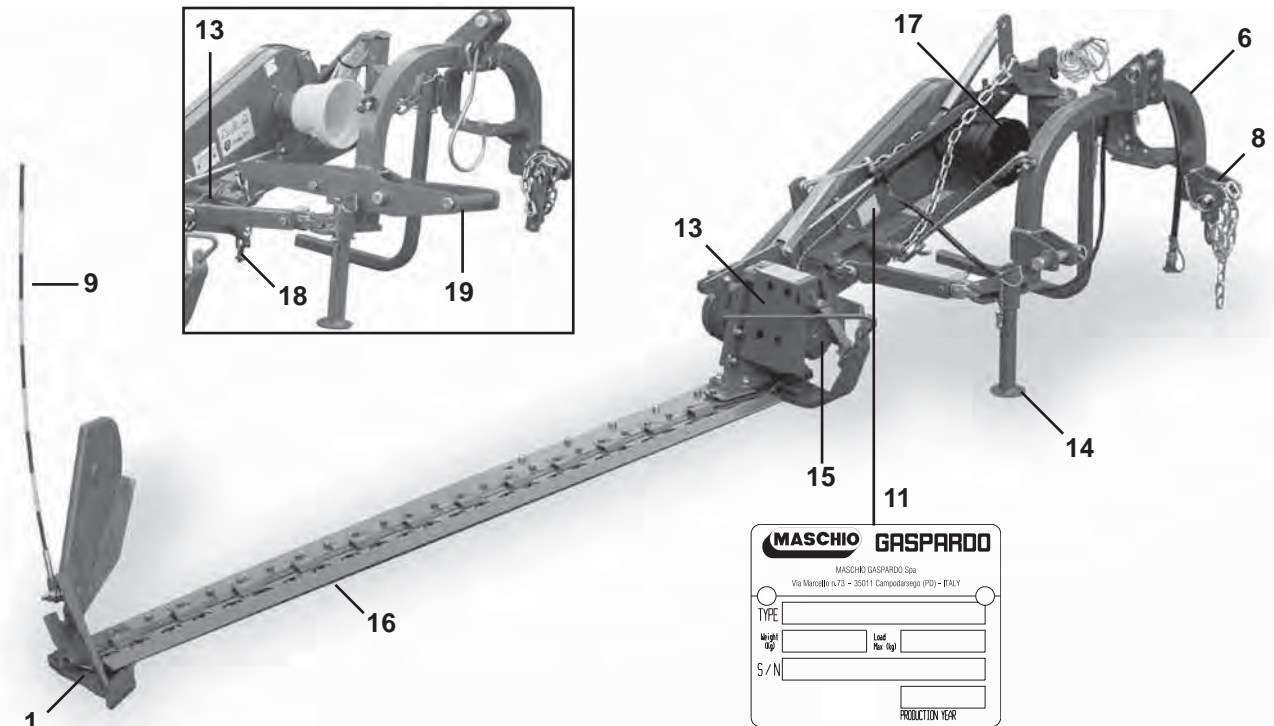
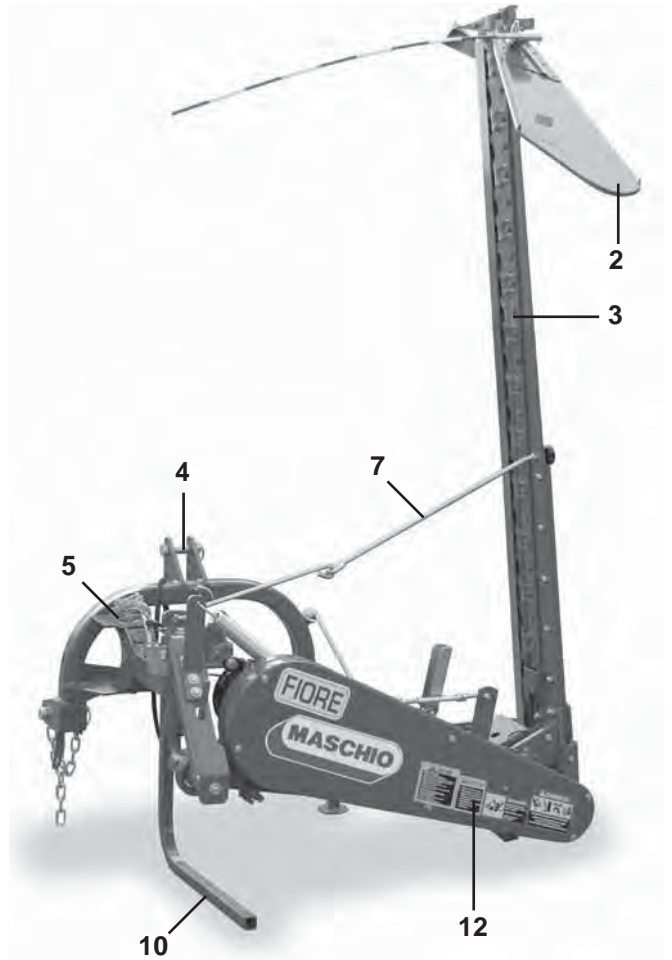

MASCHIO GASPARDO	
MASCHIO GASPARDO Spa	
Via Marelli 6/73 - 35011 Camposano (PD) - ITALY	
TYPE	<input type="text"/>
Weight (kg)	<input type="text"/>
Load (kg)	<input type="text"/>
S / N	<input type="text"/>
	<input type="text"/>
	PRODUCTION YEAR

Fig. 4

TECHNICAL SPECIFICATIONS

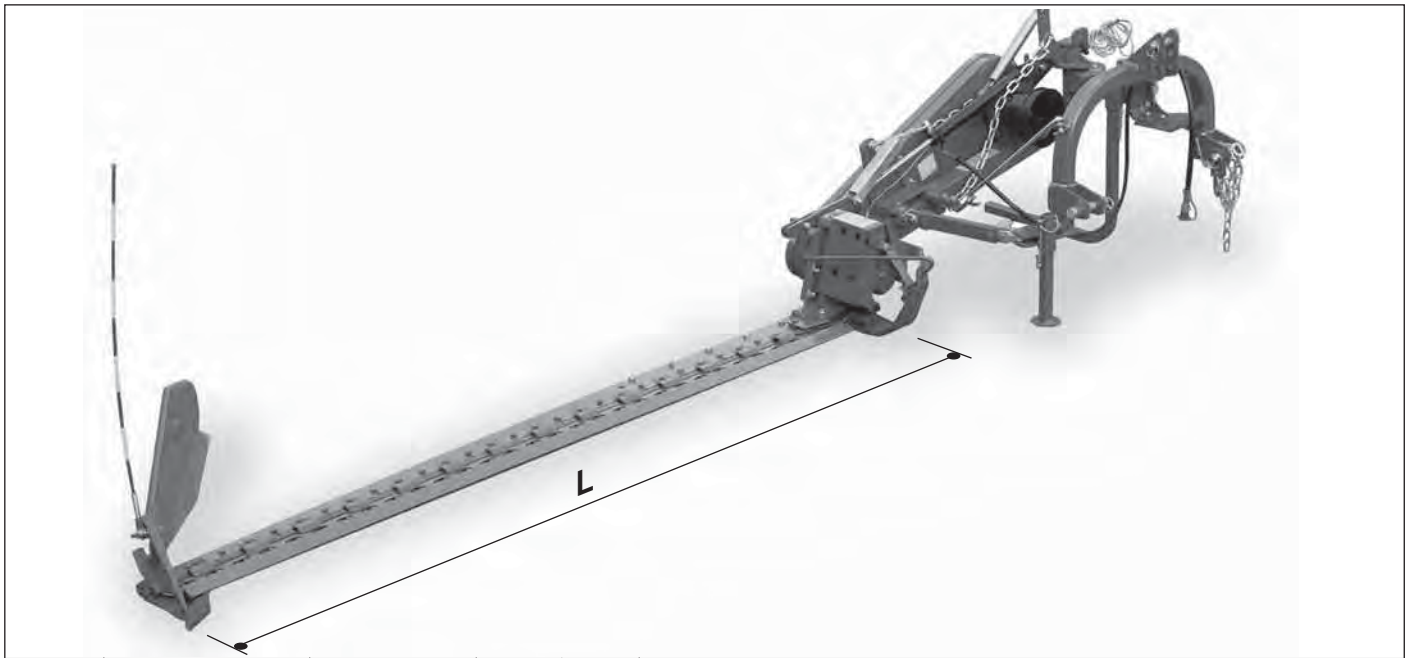

Model FIORE	Workwidth inches L	Tractor HP min. - max.	Weight lbs.	Tooth number	Sections number	Side Drive	Work speed miles/h	PTO Input speed	Hitch	Acoustic power level uttered by machine (Weighed A) L_{WA}	Continuous equivalent acoustic radiation pressure level (Weighed A) in the "worker's position" L_{pA}
1.75	68.9	25 - 50	507	12	24	Belts B-93	6.2÷7.5	540	Cat. "I" Cat. "II"	110.7 dB	91.7 dB
2.05	80.7	25 - 50	525	14	28						
2.35	92.5	25 - 50	543	16	32						

Handling

During handling operations, use suitable personal protection devices:



If the machine is handled, it must be lifted by hooking (Fig. 5) onto the appropriate holes with a suitable winch or crane of sufficient capacity. Because of the danger involved, this operation should be carried out by trained and responsible personnel. The mass of the machine is on the identification label (11, Fig. 4).

Stretch the rope to keep the machine level.

The lifting points can be detected by finding the symbol (8 page 9).

During handling operations make sure the implement has the required safety devices and guards.

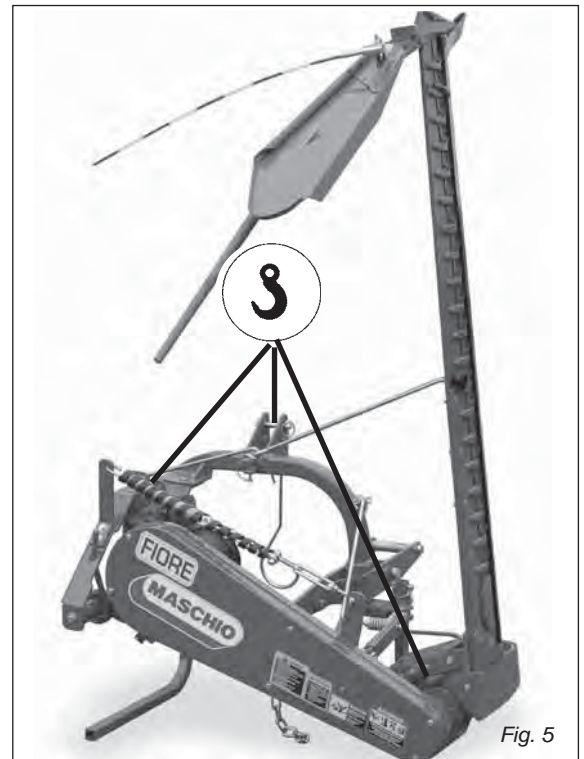

Fig. 5

SAFETY LABELS

Safety-alert labels

Read and recognize safety information.

Be alert to the potential for personal injury when you see this safety-alert labels.



On your machine safety labels, the words DANGER, WARNING, and CAUTION are used with a safety symbols. DANGER identifies the most serious hazards. In this manual, the word CAUTION and this symbol call attention to safety messages.

Identification machine

Identification label

Machine safety labels

1) CAUTION: AVOID INJURY

- Read Operator's Manual
- Ballast power unit per operator's manual
- Know location and function of controls
- Keep all shields in place
- Stay clear of power driven parts
- Never carry riders
- Keep people and pets a safe distance away from machine

BEFORE DISMOUNTING OR SERVICING

- Shut off engine and remove key
- Lock brake for park
- Lower or block up machine

2) CAUTION

- 1 Keep all shields in place.
- 2 Disengage and shut off all engine and/or motor power before servicing or unclogging machine.
- 3 Keep hands, feet and clothing away from power-driven parts.

3) DANGER: CRUSHING AND PINCH POINTS

MOVING MACHINERY PARTS CAN:

- 1° PINCH OR CRUSH OR FALL
- 2° WHICH MAY CAUSE INJURY OR DEATH.

4) DANGER

Entanglement in rotating driveline can cause serious injury or death.
Keep all shields in place.
Avoid contact with rotating parts.

5) DANGER: KEEP AWAY - SHARP BLADES

- Do not put hands or feet near the cutterbar. Blade contact can result in serious injury.
- Stay away until all motion has stopped and the mower is securely blocked up.
- Keep fingers clear of cutterbar when folding cutterbar for transport.

6) CAUTION

Operate only with 540 rpm PTO.

MASCHIO GASPARDO
MASCHIO GASPARDO Spa
Via Marcello n.73 - 35011 Campodarsego (PD) - ITALY

TYPE

Weight (kg) Load Max (kg)

S / N

PRODUCTION YEAR

MACHINE SAFETY LABELS AND POSITION





- 1** **CAUTION**
AVOID INJURY
 - READ OPERATOR'S MANUAL
 - Ballast power unit per operator's manual
 - Know location and function of controls
 - Keep all shields in place
 - Stay clear of power driven parts
 - Never carry riders
 - Keep people and pets a safe distance away from machine**BEFORE DISMOUNTING OR SERVICING**
 - Shut off engine and remove key
 - Lock brake for park
 - Lower or block up machine
- 2** **CAUTION**
 1. Keep all shields in place.
 2. Disengage and shut off all engine and/or motor power before servicing or unclogging machine.
 3. Keep hands, feet and clothing away from power-driven parts.
- 3** **DANGER**

CRUSHING AND PINCH POINTS
 MOVING MACHINERY PARTS CAN PINCH OR CRUSH OR FALL - WHICH MAY CAUSE INJURY OR DEATH.

- 4** **DANGER**

Entanglement in rotating driveline can cause serious injury or death.
 Keep all shields in place. Avoid contact with rotating parts.
- 5** **DANGER**
KEEP AWAY SHARP BLADES
 - Do not put hands or feet near the cutterbar. Blade contact can result in serious injury.
 - Stay away until all motion has stopped and the mower is securely blocked up.
 - Keep fingers clear of cutterbar when folding cutterbar for transport.

- 6** **CAUTION**
Operate only with 540 rpm PTO

- 7** 

- 8** 
- 9** 
GREASE



- 7) High noise level. Use adequate acoustic protection.
- 8) Coupling point for lifting.
- 9) Greasing point.

PREPARING THE TRACTOR

Preparing the tractor



CAUTION: Avoid injury. Proper ballasting is required for safe operation of your sickle bar mower

IMPORTANT: Refer to the tractor operator manual for proper ballasting information and tire inflation

- A 540 rpm PTO
- Refer to the tractor operator manual for correct ballasting and tire pressure, depending on installed equipment.

Parking instruction

- Stop vehicle on a level surface, not on a slope.
- Disengage PTO.
- Engage the park brake.
- STOP the engine.
- Remove the key.
- Before you leave the operator's seat, wait for engine and all moving parts to STOP.

Stay clear of rotating drivelines

Entanglement in rotating driveline can cause serious injury or death:

- Wear close fitting clothing.
- STOP the engine and be sure PTO driveline is stopped before getting near it.

Installing sickle bar on tractor

The sickle bar can be hitched to I, II or quick coupler category tractor equipped with a universal three-point coupling.



DANGER

Application of any implement to a tractor is a very dangerous operation and must only be carried out with the utmost care in compliance with the instructions.

The correct tractor/sickle bar position is established by setting the implement at such a distance from the tractor that the universal coupling remains 2-4 inches from its maximum closing position. Now proceed in the following way:

1. Back tractor into position and align draft links (A, Fig. 6) with draft link brackets on sickle bar.



CAUTION: Before you work around hitch:

- STOP engine.
- LOCK park brake.
- FIRMLY block mower on horizontal surface.

2. Connect the upper third-point and correctly regulate by means of the adjuster (B, Fig. 7). Place plate (C, Fig. 7) at the left side of the hitch integral with the same pin. Lock in place with the snap-in split pins (D, Fig. 8).

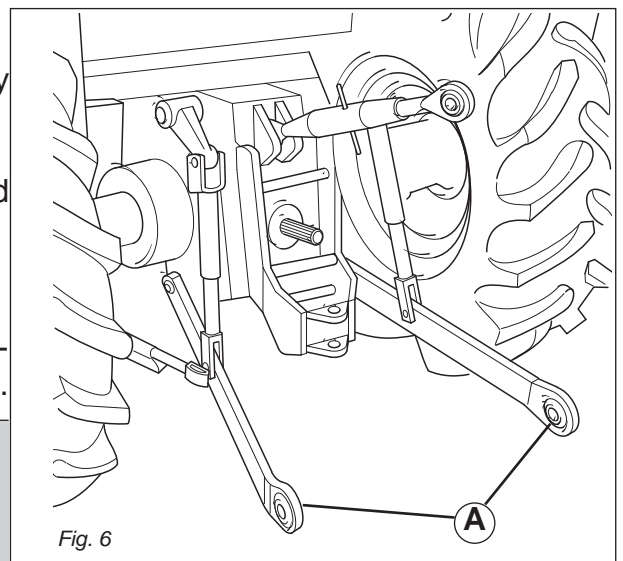

Fig. 6

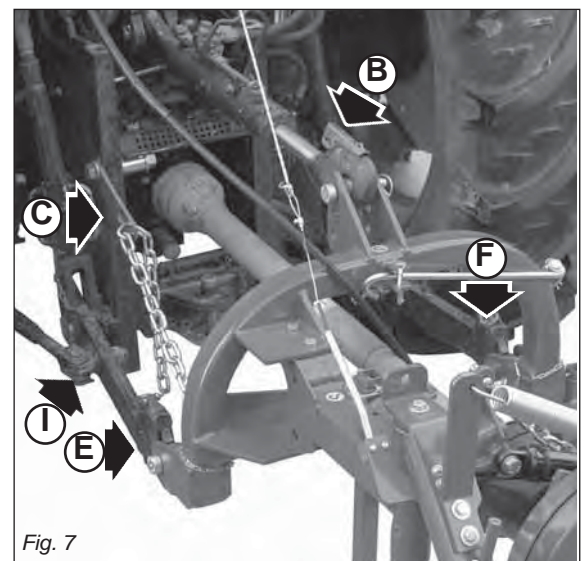
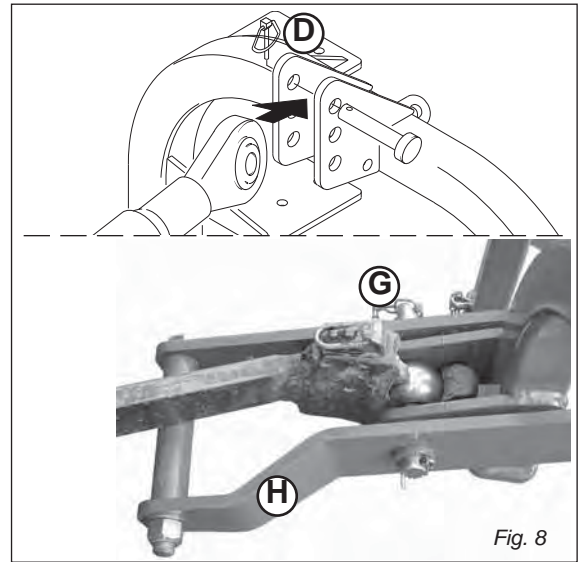

Fig. 7

INSTALLING

- Hook the oscillating arms of the tractor to pins (E and F, Fig. 7). The hoisting arm (H, Fig. 8) must be fixed underneath the tractor arm. Lock in place with the snap-in split pins (G Fig. 8)
- Lock the lift links using the relative chains (I, Fig. 7) and couplings parallel to the tractor. This operation must be carried out to prevent the machine from moving in a horizontal direction.



- Install PTO shaft to tractor (Fig. 9).

IMPORTANT: Sickle bar mower MUST BE level front to rear.

Make sure PTO shaft is locked on the tractor PTO prior to engagement (L). Check that the guard (M) is free to turn and fix it with the relative latch (M1).

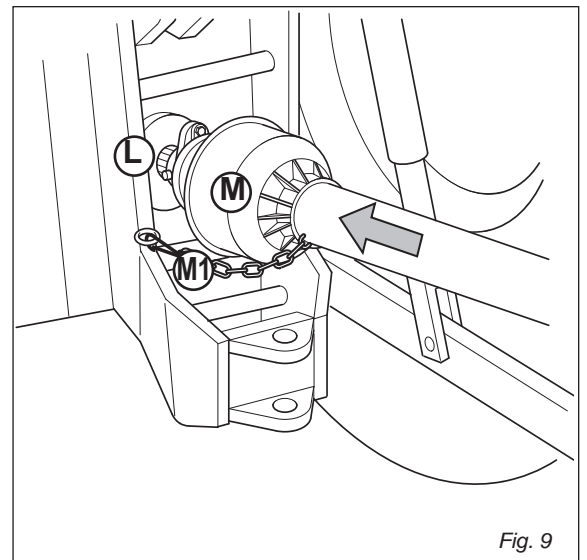

- Remove the guard over the cutters (16, Fig. 4) and remove the tirant (7, Fig.4).
- Lift-up sickle bar.
- Remove spring locking pin (N, Fig. 10) from parking stand.
- Remove support (O and P, Fig. 10) and remount them, upside-down in their seat .
- Fasten with spring locking pin (N, Fig. 10).

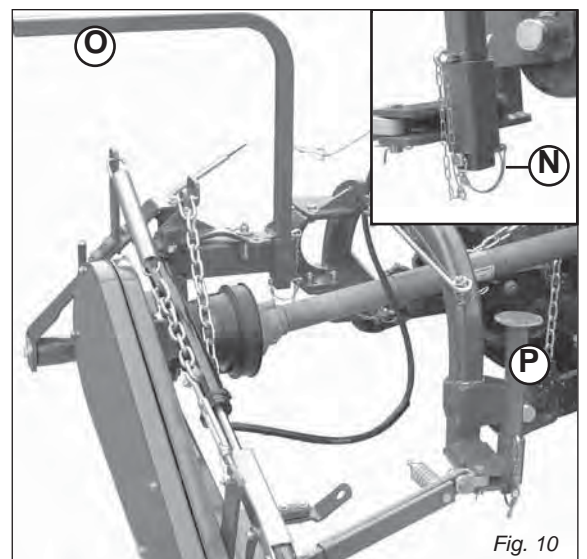

INSTALLING

PTO shaft adaptation

The PTO shaft, supplied with the machine, is of standard length. Therefore it might be necessary to adapt the PTO shaft. In that case, before doing anything, consult the Manufacturer for the eventual adaptation.



CAUTION

- When the PTO shaft is fully extended, the two tubes must overlap by at least 6 inches (Q Fig. 11). When fully inserted, the minimum play must be $1\frac{37}{64}$ inches (R Fig.11).
- If the implement is used on another tractor, always check the above and that the guards completely cover the rotating parts of the PTO shaft.



ATTENTION

- Comply with the manufacturer's instructions when transporting the mowing machine.

- The equipment installed can only be controlled by means of the PTO shaft complete with the necessary overload safety (i.e. clutch) devices and guards fastened with the appropriate chain.
- Only the PTO shaft supplied by the Manufacturer must be used.
- The engine must not be running when installing and removing the PTO shaft.
- Care must be taken regarding the safety and correct assembly of the PTO shaft.
- Use the chain provided to stop the PTO shaft from rotating.
- Always check carefully that the PTO shaft guard is always in position, both during transportation and operation.
- Frequently and set intervals check the PTO shaft guard, it must always be in excellent condition.
- Before engaging the PTO, check that the set rpm corresponds to that indicated by the sticker on the equipment.
- Before inserting the PTO, make sure that there are no people or animals nearby and that the rpm selected corresponds to that permitted. Never exceed the maximum admissible speed.
- Watch out for the rotating universal joint.
- Do not insert the PTO with the engine off or synchronized with the wheels.
- Always disconnect the PTO when the cardan shaft is at too wide an angle (never more than 10° , Fig. 12) and when it is not being used.
- Only clean and grease the PTO shaft when the power take-off is disconnected, the engine is off, the hand brake pulled and the key removed.
- When not in use, place the PTO shaft on the support provided for it.
- After having dismantled the PTO, place the protective cover on the PTO shaft (S, Fig. 13).

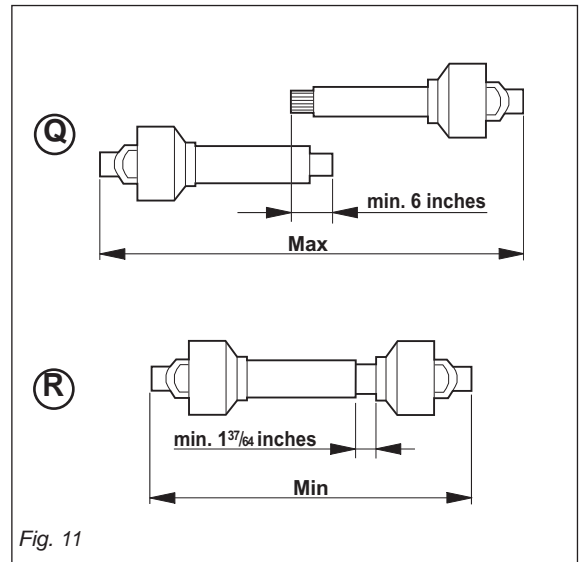

Fig. 11

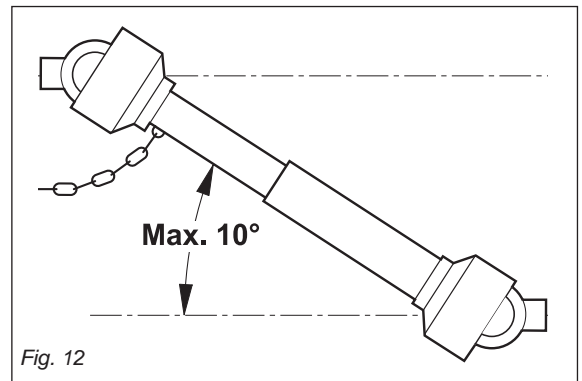

Fig. 12



Fig. 13

INSTALLING

Stability of sickle bar mower and tractor during transport

When a sickle bar is coupled to a tractor, so becoming an integral part of it for the purposes of road travel, the stability of the sickle bar-tractor complex may change and cause driving or operating difficulties (rearing up or side-slipping of the tractor). The condition of equilibrium can be restored by placing a sufficient number of ballasts on the front of the tractor so that the weights on the two tractor axles are distributed sufficiently evenly. To work in safety the instructions given in the highway code should be followed; these prescribe that at least 20% of the weight of the tractor alone should be borne by the front axle and that the weight on the arms of the hoist should not be more than 30% of the weight of the tractor itself. These factors are summarized in the following formulas:

$$Z > \frac{(M \times s) - (0.2 \times T \times i)}{(d+i)}$$

The amount of ballast that should be applied according to the formula is the minimum required for circulation on the road. If for reasons of tractor performance or to improve the set-up of the sickle bar during operation it is thought necessary to raise these values, please refer to the registration document of the tractor to check its limits. When the formula for calculating the ballast gives a negative result it will not be necessary to add any weight. In any case, as long as the limits of the tractor are respected, a suitable quantity of weights may be applied in order to ensure greater stability during travel. The symbols have the following meanings:

M	Kg	Mass weighing on arms off hoist with full load (Technical data table)
T	Kg	Mass of tractor
Z	Kg	Total mass of ballast
i	m	Tractor wheelbase, that is, the horizontal distance between the tractor axles
d	m	Horizontal distance between the centre of gravity of the ballast and the front axle of the tractor
s	m	Horizontal distance between the centre of gravity of the operating machine and the back axle of the tractor

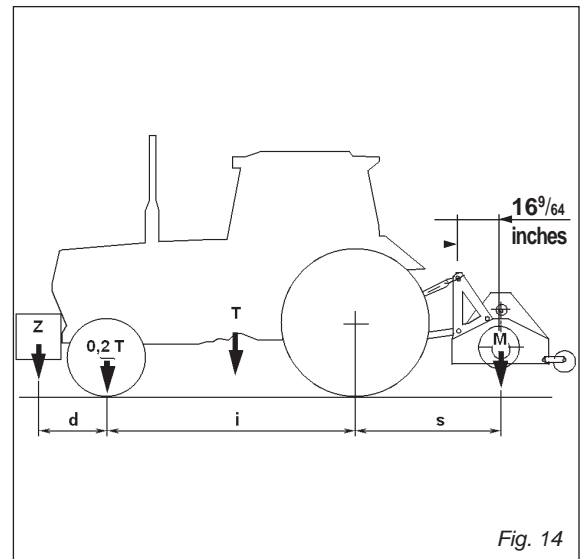

(please see Fig. 14 for reference):

INSTALLING

Parking instructions

- Stop vehicle on a level surface, not on a slope.
- Disengage PTO.
- Engage the park brake.
- STOP the engine.
- Remove the key.
- Before you leave the operator's seat, wait for engine and all moving parts to STOP.

Stay clear of rotating drivelines

Entanglement in rotating driveline can cause serious injury or death:

- Wear close fitting clothing.
- STOP the engine and be sure PTO driveline is stopped before getting near it.



REMOVING

Removing sickle bar mower

The sickle bar must be set-up on flat and compact ground, supported by the relative supports (A and B, Fig. 15).

1. Raise sickle bar.
2. Put parking stand (A and B, Fig. 15) in the DOWN position: install spring locking pin in order to secure parking stand (C, Fig. 15).
3. Lower sickle bar to the ground.

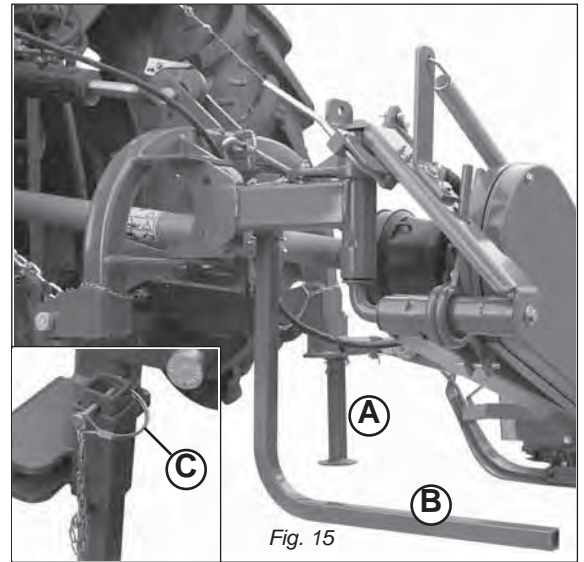

CAUTION: Before you work around hitch:

- STOP engine.
- LOCK park brake.
- FIRMLY block mower on horizontal surface.

4. Unhook the PTO shaft (, Fig. 16) from the tractor and put in on the special hook.
5. Remove quik-lock pin (D, Fig. 17) and pin (E, Fig. 17) from center link (F, Fig. 17).

NOTE: Put quik-lock pins and pins back into brackets on sickle bar for storage.

6. Remove draft links (J, Fig. 17) from draft link brackets (G, Fig. 17) by removing quiklock pins (H, Fig. 17) and pins (I, Fig. 17).

NOTE: Put quik-lock pins and pins back into brackets on sickle bar for storage.

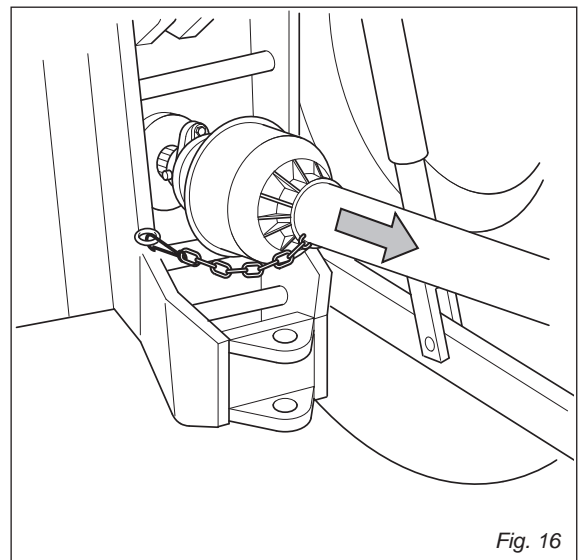

7. Drive tractor forward slowly.

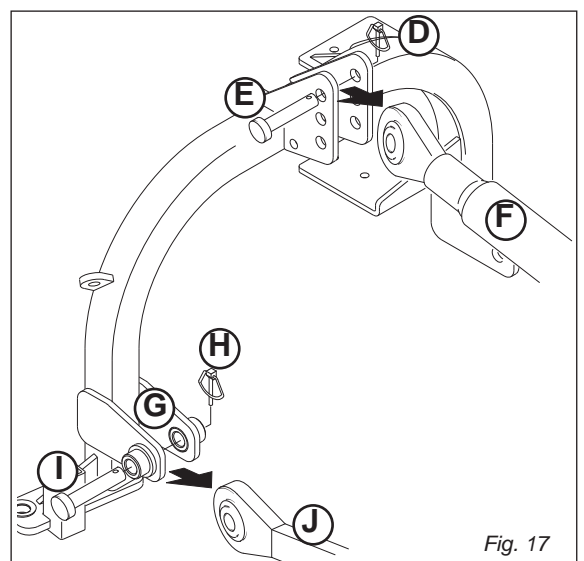

OPERATING

Operate safely

Carefully read all the instructions before using the machine; if in doubt, contact the technicians of the Manufacturer's dealer. The manufacturer declines all responsibility for the non-observance of the safety and accident prevention regulations described below.

General norms

- 1) Pay close attention to the danger signs in this manual and on the sickle bar.
- 2) The labels with the instructions attached to the machine give abbreviated advice for avoiding accidents.
- 3) Carefully observe, with the help of the instructions, the safety and accident prevention regulations.
- 4) Avoid touching moving parts in any way whatsoever.
- 5) Any work on and adjustment to the machine must always be done with the engine switched off and the tractor blocked.
- 6) People or animals must not, under any circumstances, be transported on the equipment.
- 7) It is strictly prohibited to drive the tractor, or allow it to be driven or with the equipment attached by persons not in possession of a driver's license, an expert or in poor conditions of health.
- 8) Before starting the tractor and the equipment, check that all safety devices for transport and use are in perfect working order.
- 9) Before starting up the equipment, check the area surrounding the machine to ensure that there are no people, especially children or pets, nearby, and ensure that you have excellent visibility.
- 10) Use suitable clothing. Avoid loose clothing or garments with parts that could in any way get caught in the rotating or moving parts of the machine.
- 11) Before starting work, familiarize yourself with the control devices and their functions.
- 12) Only start working with the equipment if all the protective devices are in perfect condition, installed and in the safe position.
- 13) It is absolutely prohibited to stand within the machine's radius of action where there are moving parts.
- 14) It is absolutely forbidden to use the equipment without the guards.
- 15) Before leaving the tractor, lower the implement coupled to the lift unit, stop the engine, engage the hand brake, remove the ignition key from the control panel, cover the cutters and outer skid with the relative guards. Raise the mowing bar (transport protection) according with the instructions given in this handbook.
- 16) The driver's seat must never be left when the tractor engine is running.
- 17) Before operating the mowing machine, check that the support struts (A and B, Fig. 15 page 15) have been removed from underneath the implement. Make sure that the sickle bar has been correctly mounted and adjusted. Check that the machine is in perfect order and that all components subject to wear and deterioration are efficient.
- 18) Before releasing the equipment from the third point attachment, put the hoist command lever into the locked position and lower the support feet.
- 19) Only operate during daylight or with proper artificial light.
- 20) All operations must be carried out by expert personnel, equipped with protective gloves, in a clean and dust-free environment.
- 21) Do not climb onto the machine while it is running, even if it is stationary.
- 22) Before approaching the mowing bar, disengage the pto, switch off the tractor, engage the parking brake and check that the cutters are at a complete standstill.
- 23) The coupled implement may only be controlled through the PTO shaft complete with the necessary safety devices for overloads and with the guards fixed with the relative latch.
- 24) During maintenance and work operations, make sure that no other person goes near the tractor and the implement and accidentally works the controls with the risk of causing injury to persons and damage to property.
- 25) As a precaution, always set adequate supports under the implement during assembly, servicing, cleaning or assembly work with the mowing bar raised.

OPERATING

- 26) DO NOT wear radio or music headphones while operating the machine. Safe operation requires your full attention.
- 27) DO NOT operate the tractor and sickle bar when you are tired or ill.

Tractor hitch

- 1) Hook the equipment to a suitable, sufficiently-powered tractor by means of the appropriate device (lifter), in conformity with applicable standards.
- 2) The class of the equipment attachment pins must be the same as that of the lifter attachment.
- 3) Take care when working within the range of the lifting arms as this is a very dangerous area.
- 4) Be very careful when hooking and unhooking the equipment.

 5) **It is absolutely forbidden to stand between the tractor and linkage for acting the lifting controls from the outside (Fig. 18).**

- 6) It is absolutely forbidden to stand in the space between the tractor and the equipment (Fig. 18) with the engine running.
- 7) The attaching of additional equipment onto the tractor brings about a different distribution of weight on the axles. Check the compatibility of the tractor performance with the weight that the mower transfers onto the three-point linkage. If in doubt consult the tractor Manufacturer.
- 8) Comply with the maximum admissible weight for the axle, the total mobile weight, transport regulations and the highway code.

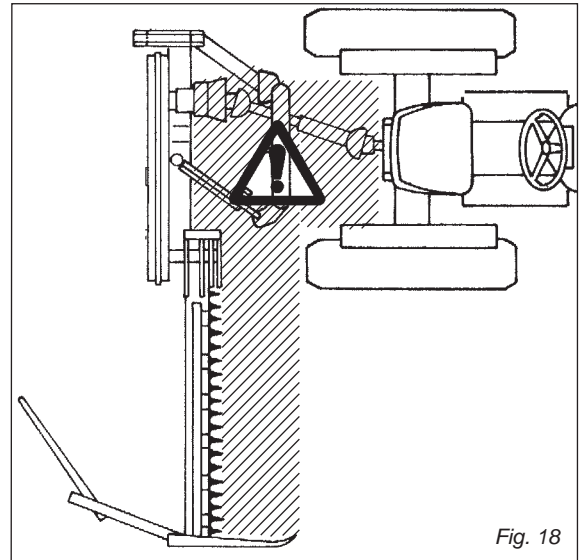

Wear appropriate clothing

- Wear close fitting clothing and safety equipment appropriate for the job.
- Loud noise can cause impairment or loss of hearing, wear a suitable protective device such as earplugs.



Stay clear of rotating drivelines

Entanglement in rotating driveline can cause serious injury or death:

- Wear close fitting clothing
- Stop the engine and be sure PTO shaft is stopped before getting near it.



 **CAUTION: Before you work around hitch:**

- **STOP** engine.
- **LOCK** park brake.
- **FIRMLY** block mower on horizontal surface.

OPERATING - MECHANICAL LIFTING SYSTEM

Use of MECHANICAL lifting system (Fig. 19)

Adapting the sickle bar mower

To ensure optimum use, the sickle bar must completely project from the tractor (Fig. 20); three situations are shown in the Figure 21:

- 1) hitching to a tractor normally used for mowing jobs;
- 2) hitching to a large tractor;
- 3) hitching to a small tractor or to certain types of tracked vehicle.

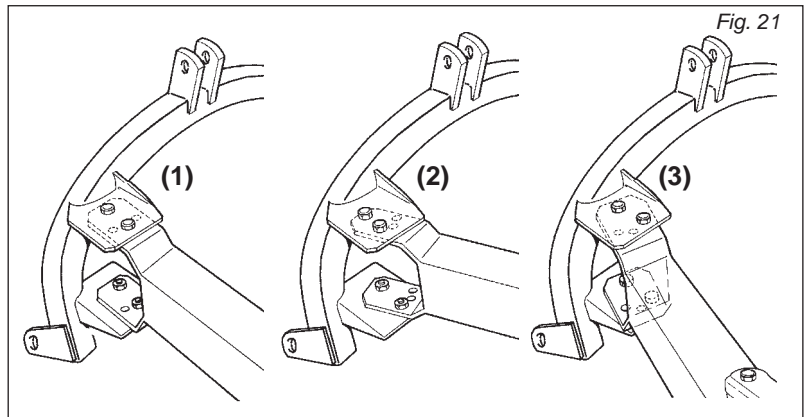
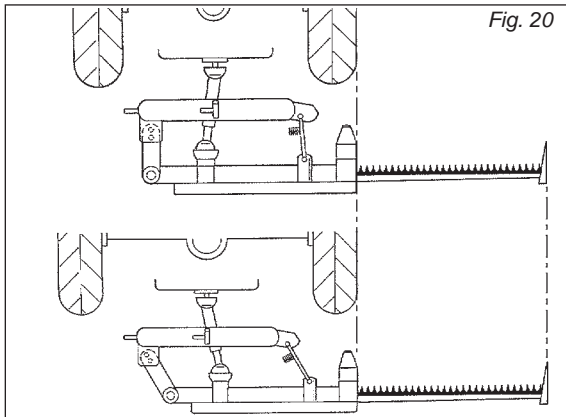
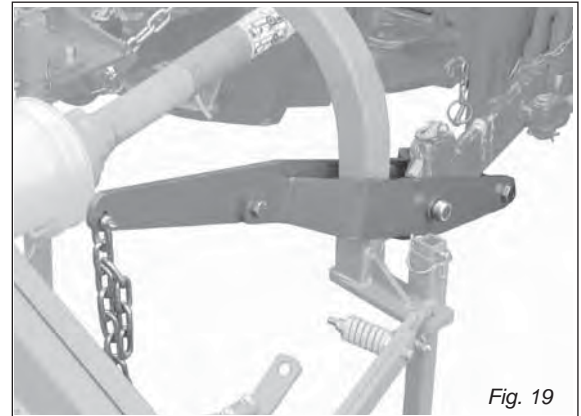

Adjustment

Before starting a mowing session, adjust the machine so that the best working setup is obtained. Correct machine setup guarantees excellent mowing, allows for the best machine-tractor performance and remarkably reduces wear of the cutting blades.

- Remove safety hook (D, Fig. 22), required only for transportation, and fit it back in the slot positioned above the chassis.
- Fit the sickle bar by adjusting the tractor tie-rods so that, when the sickle bar attachment is fitted to the three points on the tractor, the external tip of the cutting arm is approximately 2 inches forward with respect to the arm base (Fig. 23).

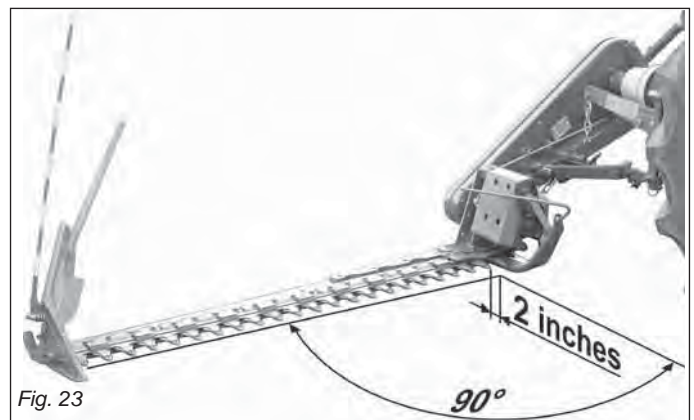
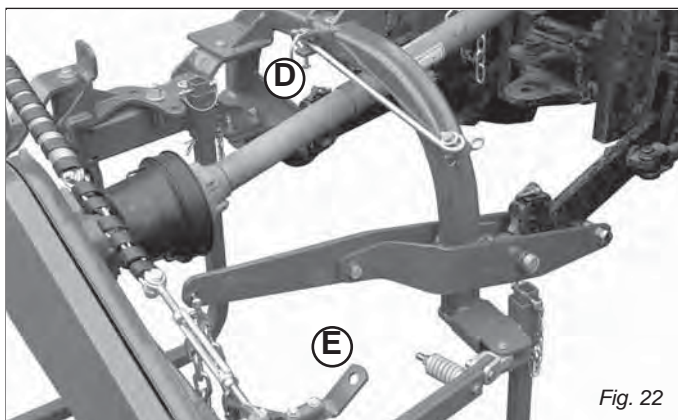

OPERATING - MECHANICAL LIFTING SYSTEM

- Connect one end of the chain (F, Fig. 24) to the mower using the supplied pin and the other end to a stationary point on the tractor. Adjust the height of the mower to the ground (19.6 to 21.7 inches, Fig. 24) by moving the rings of the chain (F, Fig. 24) in the hole on the plate (G, Fig. 24). When the lifter is lowered, this precaution will constantly hold the mower at the same height from ground level.

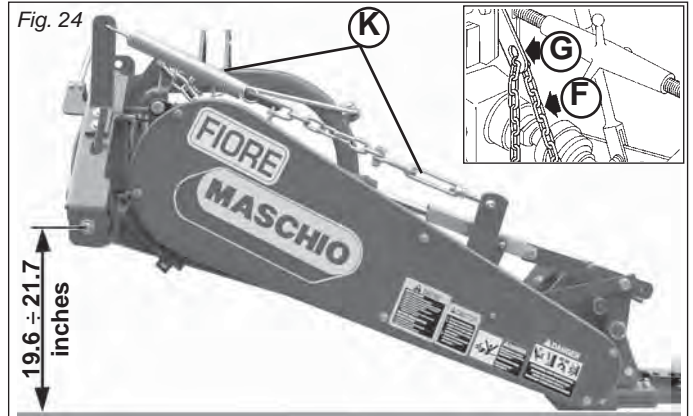

- Act on the tie rod-spring (K, Fig. 24) to bring the internal skid close to the ground (without discharging the weight on the ground), lightening the load of the machine on the cutter bar.
- Adjusting the hoisting chain (H, Fig. 25) so that during mowing the hoisting arm (I, Fig. 25) is free to move up and down; in this way, the cutting arm can follow any unevenness of the ground.

So that the mower will work well, we advise you to fix the chain (H Fig. 25) to the lifting arm (I Fig. 25) at the level of the 7th or 8th link of the chain.

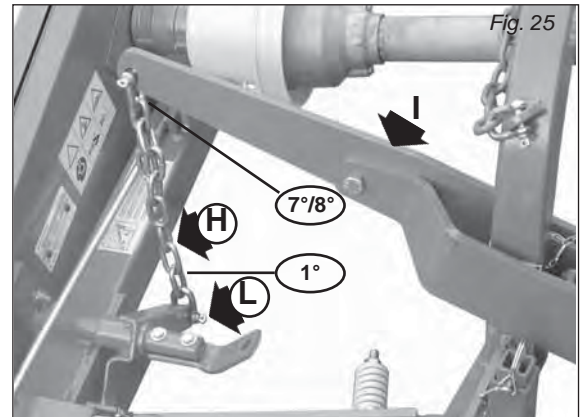

- Adjust the height of the cutting arm from the ground with chain (J, Fig. 26). Lower the mower; when the external tip of the arm touches the ground, the inner shoe must remain approximately 10 cm. above ground level (Fig. 26). Adjust by moving the chain links.

So that the mower will work well, we advise you to fix the chain (J, Fig. 25-26) to the equalizer (L, Fig. 25-26), leaving the last links of the chain free.

- Adjust inclination of the cutting arm teeth using tie rod (M, Fig. 27).

For low, moist and thick fodder, tilt the teeth downwards by shortening the tie rod (M, Fig. 27).

For ground with rocks and stones tilt the teeth upwards by lengthening the tie rod (M, Fig. 27).

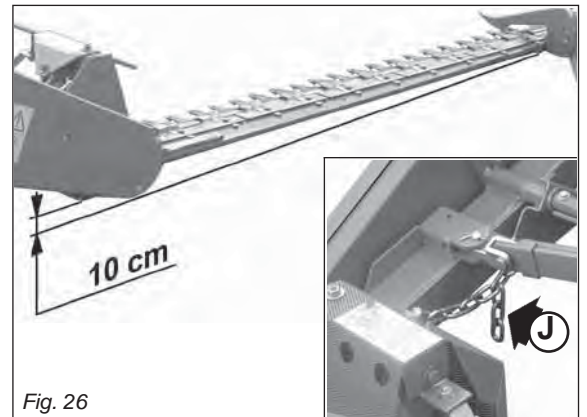

- Adjust the cutting height (Fig. 28) by moving the mowing bar on the holes of the inner mowing bar support (N), and, turning the nut of the outer mowing bar support (M), bring it level with the ground.

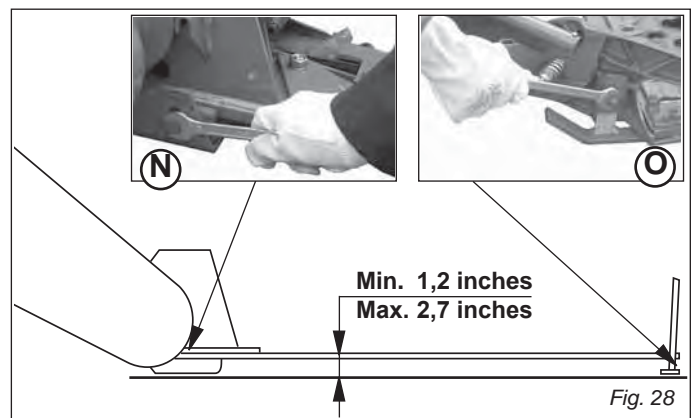
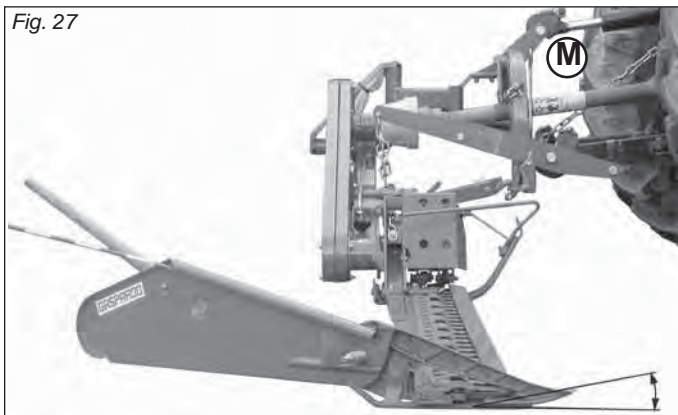

OPERATING - MECHANICAL LIFTING SYSTEM

Mowing

- Remove the supports (P and Q, Fig. 29) and remount them, upside-down in their seat . Install spring locking pin in order to secure parking stand (R).

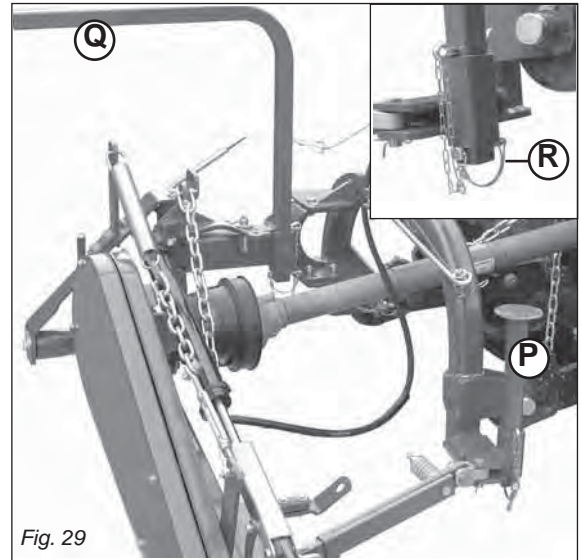

- Remove tie rod (S, Fig. 30) from the cutting arm.
- Remove safety hook (D, Fig. 22), required only for transportation, and fit it back in the slot positioned above the chassis.
- The sickle bar is fitted with a safety device for protection against obstacles. If this device is tripped by impact with an obstacle, stop the tractor without raising the cutting arm. Check that the cardan shaft has not become separated, if so, reassemble it. **Position the safety tie rod parallel to the ground, and reverse the tractor until the safety tie rod hooks up again.** If the tie rod releases easily, adjust spring (T, Fig. 31) using nut (U, Fig. 31) which should be tightened half turn at a time.

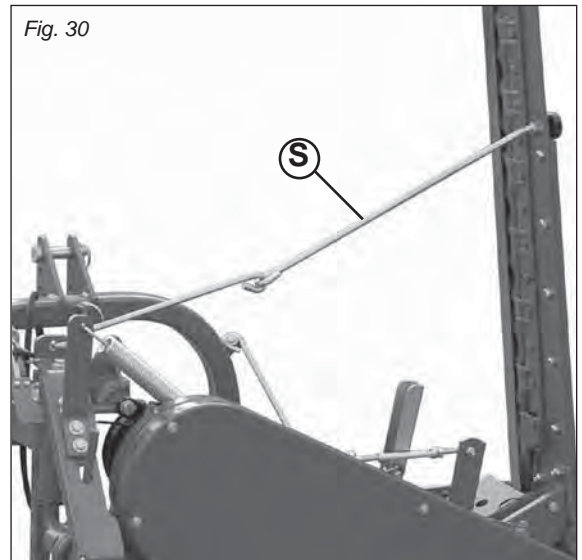

ATTENTION

A spring compression other than that indicated in Figure 31 (0.59 inches) can make the safety device ineffective.

For successful mowing and to avoid jamming, we advise you to:

- **Set and maintain the power take-off at a constant rate of 540 rpm to ensure correct blade frequency; maintain an engine speed of 1800÷2000 rpm.**
- compatibly with the soil conditions and the type of grass, maintain a steady work speed: no slower than 5 mph to favor the discharging of the mown grass and no faster than 6.2 mph to avoid breaking or damaging the machine's structure.
- if the grass is tangled or flattened, keep the cutting bar grazing the ground.

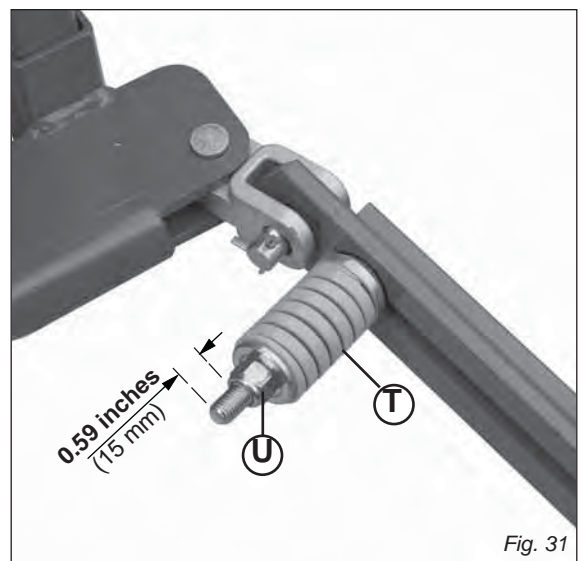

OPERATING - MECHANICAL LIFTING SYSTEM



ATTENTION

If the blades becomes jammed, it is advisable to operate carefully wearing suitable personal protection. All the maintenance, adjustments and work preparation operations, must be carried out with the tractor strictly switched off and properly stationary, with the ignition key turned off and the sickle bar on the ground.



CAUTION

- Always raise the implement in order to reverse or change direction.
- The cutting arm should not be raised abruptly in order to avoid damaging the cutting blades.
- Power take-off must not exceed 540 r.p.m.
- Never run the engine at maximum power while mowing.
- In order to prevent breakages or damage, the speed of the tractor must never exceed 6.2 mph when the implement is working.



DANGER

The mowing machine has sharp cutting blades. Always make sure that there are no persons, domestic animals, electrical cables, pipes and so forth, within the field of action of the implement.

OPERATING - HYDRAULIC LIFTING SYSTEM

Use of HYDRAULIC lifting system (Fig. 32)

To install the hydraulic lifting kit of the mower, on versions with mechanical lifting, it is necessary to remove some parts of the equipment. Some pieces to be detached from the equipment are indicated on page 23 (ref. 1). Install the Kit following the instructions given on page 23 (ref. 2 to 11).

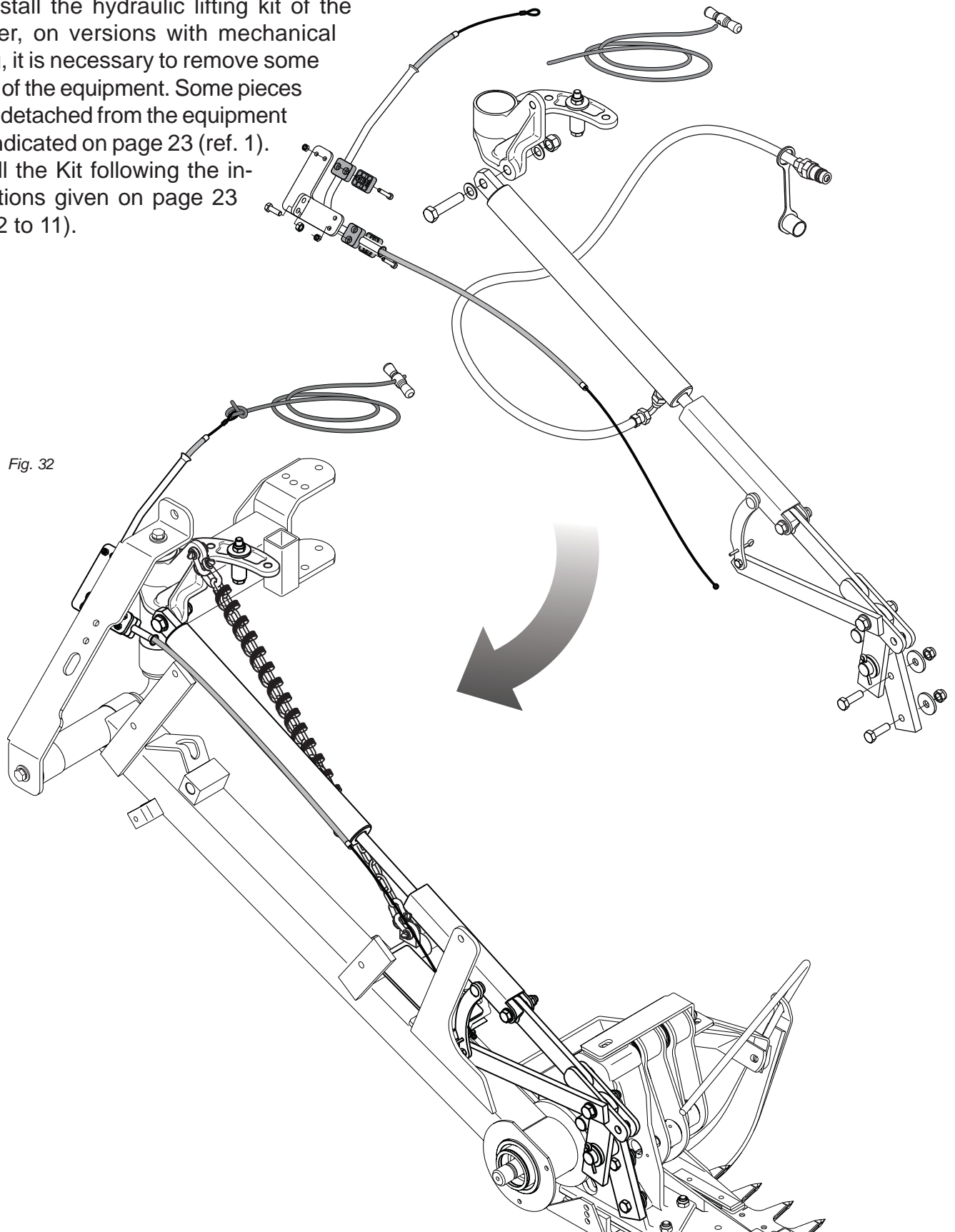
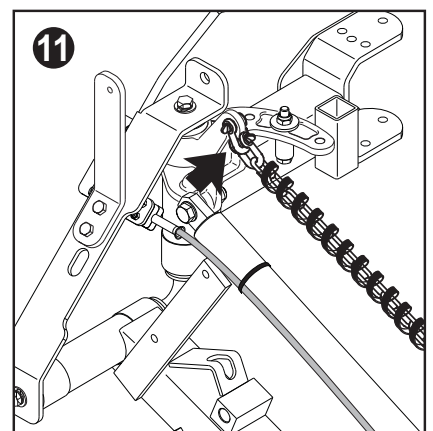
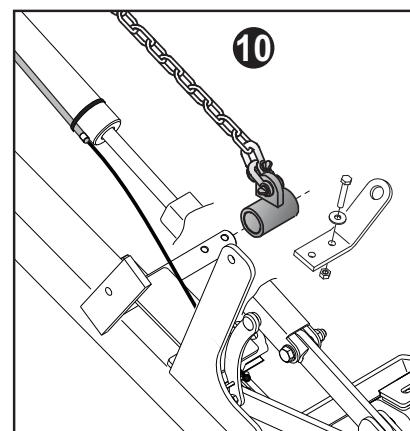
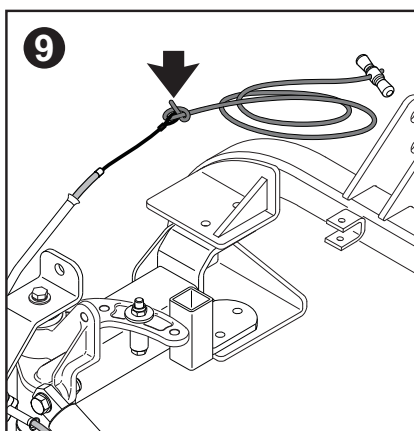
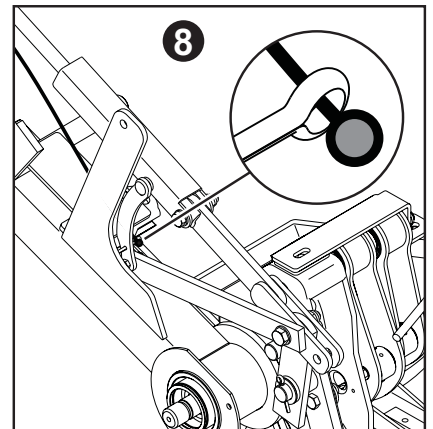
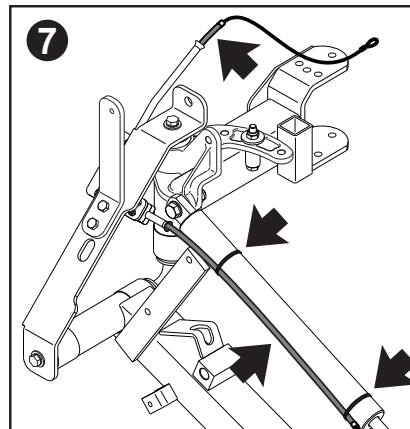
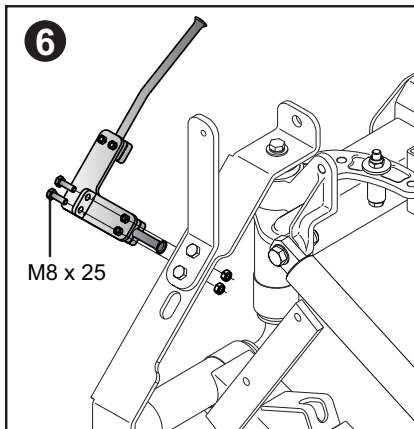
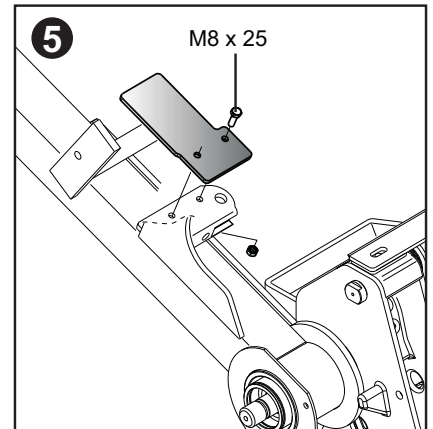
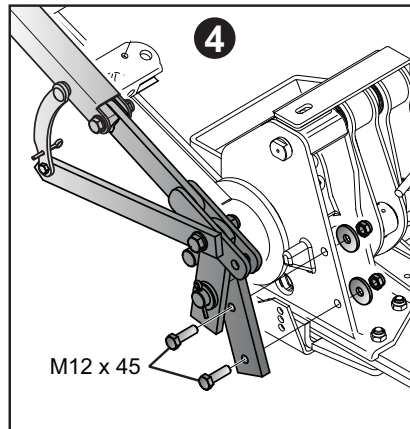
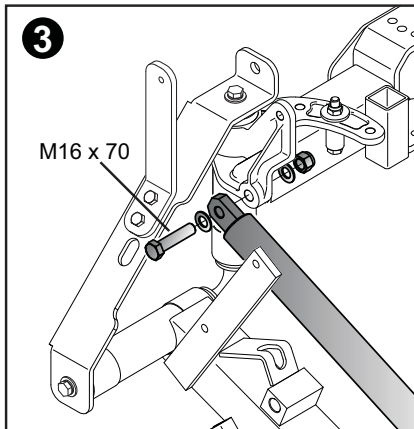
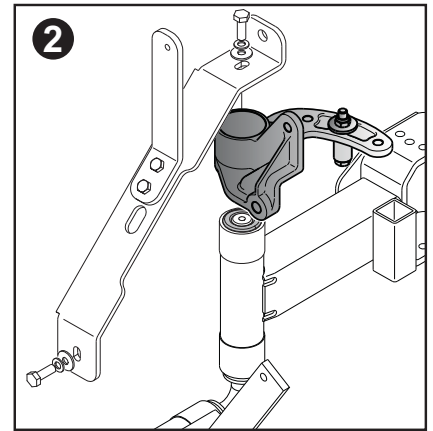
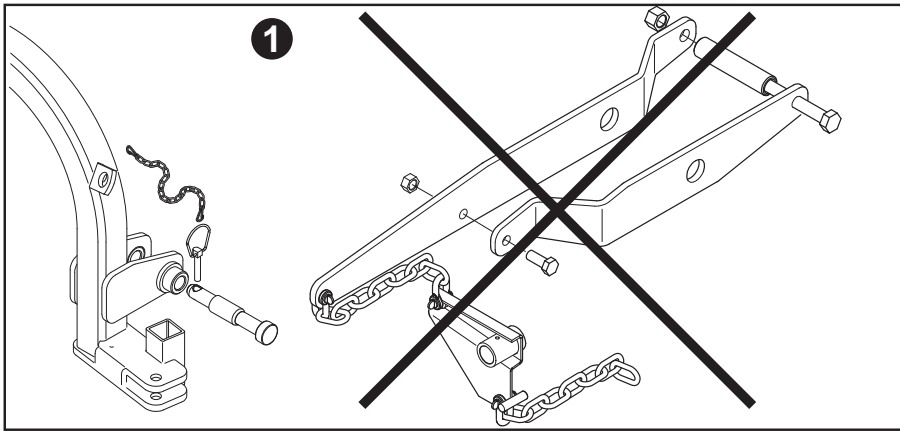

Fig. 32

OPERATING - HYDRAULIC LIFTING SYSTEM



OPERATING - HYDRAULIC LIFTING SYSTEM

Adapting the sickle bar mower

To ensure optimum use, the sickle bar must completely project from the tractor (Fig. 33); three situations are shown in the Figure 34:

- 1) hitching to a tractor normally used for mowing jobs;
- 2) hitching to a large tractor;
- 3) hitching to a small tractor or to certain types of tracked vehicle.

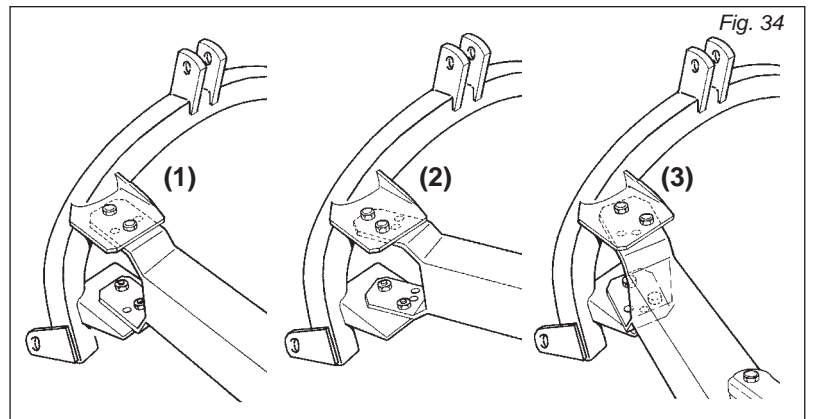
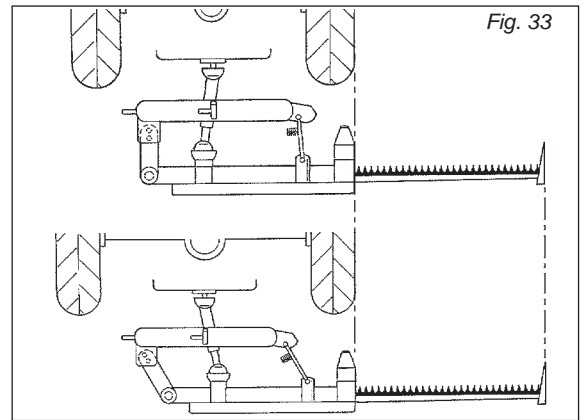

When the frame joint is moved (A, Fig. 35), the position of the stop bushing (C, Fig. 35) of the cylinder linkage must consequently be changed, according to the cases shown in figures 35 and 36.

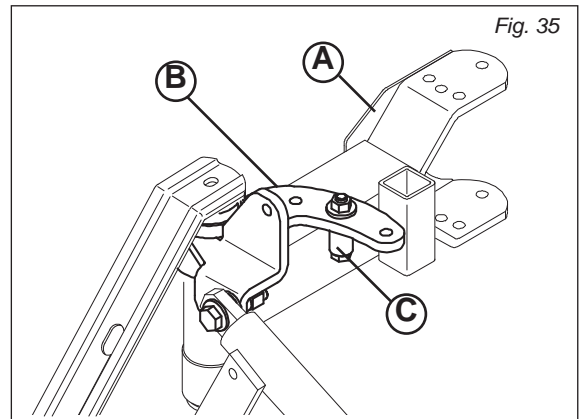

Connections between frame joint and stop bushing for the movement of the mowing bar.

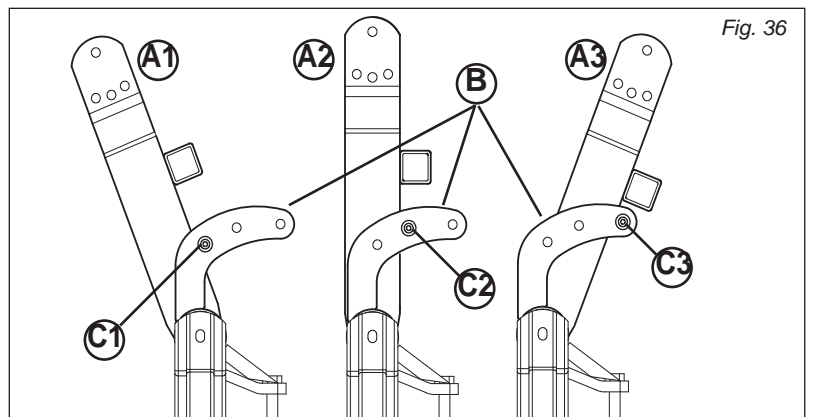

OPERATING - HYDRAULIC LIFTING SYSTEM

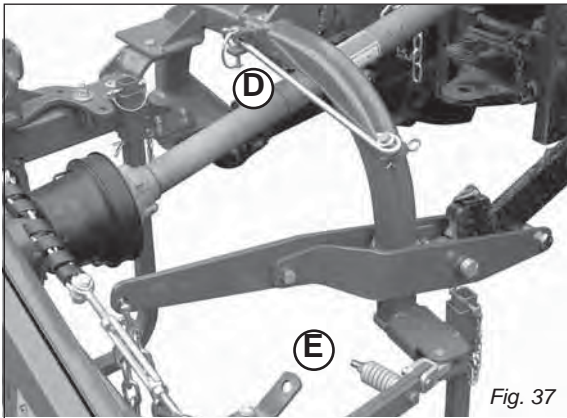

Fig. 37

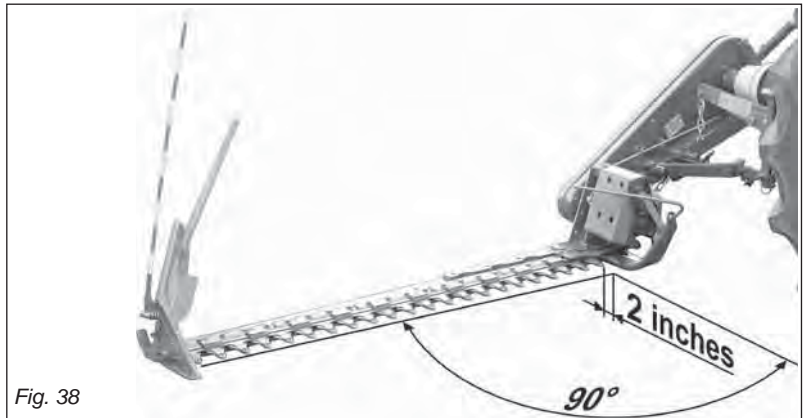

Fig. 38

Adjustment

Before starting a mowing session, adjust the machine so that the best working setup is obtained. Correct machine setup guarantees excellent mowing, allows for the best machine-tractor performance and remarkably reduces wear of the cutting blades.

- Remove safety hook (D, Fig. 37), required only for transportation, and fit it back in the slot positioned above the chassis.
- Fit the sickle bar by adjusting the tractor tie-rods so that, when the sickle bar attachment is fitted to the three points on the tractor, the external tip of the cutting arm is approximately 2 inches forward with respect to the arm base (Fig. 38).
- Connect one end of the chain (F, Fig. 39) to the mower using the supplied pin and the other end to a stationary point on the tractor. Adjust the height of the mower to the ground (19.6 to 21.7 inches, Fig. 39) by moving the rings of the chain (F, Fig. 39) in the hole on the plate (G, Fig. 39).

When the lifter is lowered, this precaution will constantly hold the mower at the same height from ground level.

- Act on the tie rod-spring (K, Fig. 39) to bring the internal skid close to the ground (without discharging the weight on the ground), lightening the load of the machine on the cutter bar.
- Adjust inclination of the cutting arm teeth using tie rod (M, Fig. 40).
for low, moist and thick fodder, tilt the teeth downwards by shortening the tie rod (M, Fig. 40).
for ground with rocks and stones tilt the teeth upwards by lengthening the tie rod (M, Fig. 40).

- Adjust the cutting height (Fig. 41) by moving the mowing bar on the holes of the inner mowing bar support (N), and, turning the nut of the outer mowing bar support (O), bring it level with the ground.

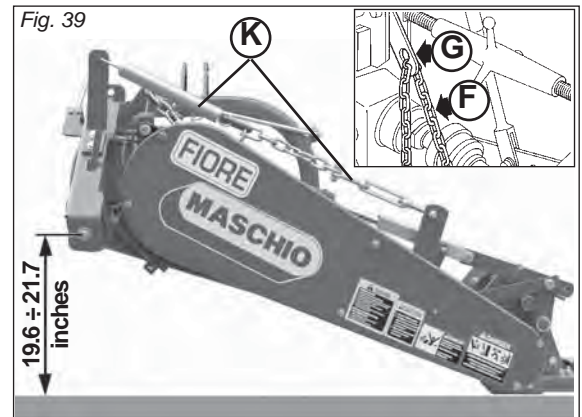

Fig. 39

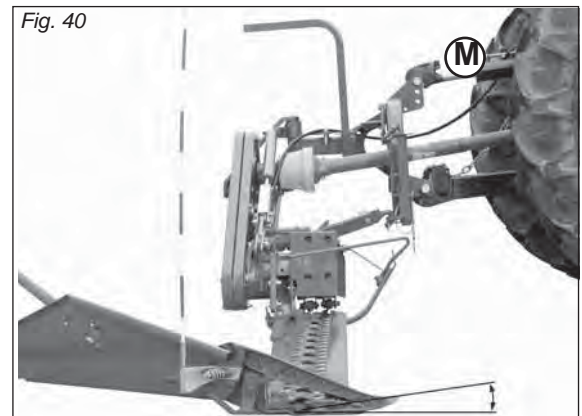

Fig. 40

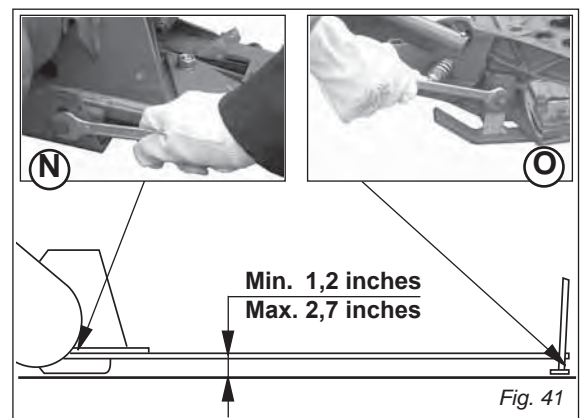

Fig. 41

OPERATING - HYDRAULIC LIFTING SYSTEM

Using the lifting device

Once you have positioned the equipment, prepare it for mowing:

- release the blade tie rod;
- remove the support prop;
- remove the blade protection.

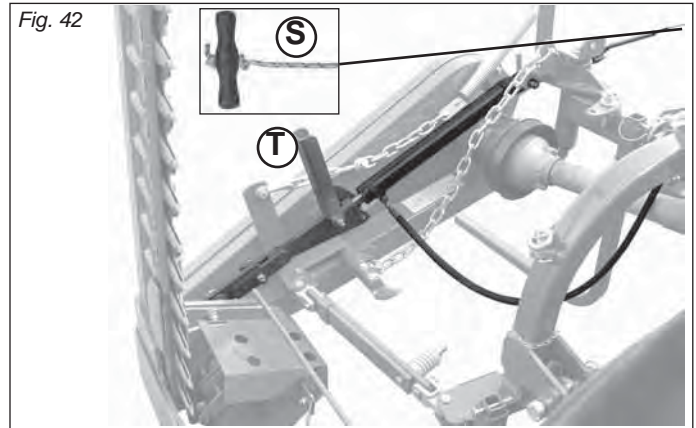

Operation of lifting device

Put the rope (S, Fig. 42) for releasing the bracket (T, Fig. 42) inside the tractor cabin.

Climb into the tractor and operate the hydraulic distributor to lower the blade (Fig. 43) into the mowing position.

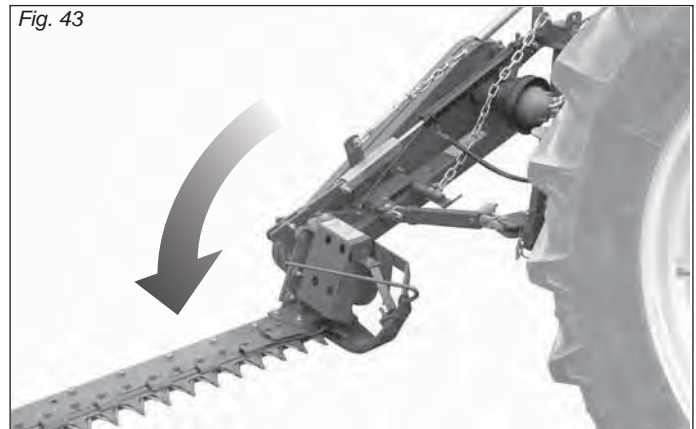

CAUTION: While working regularly check that the bracket (T) is still resting along the cylinder rod (Fig. 44).

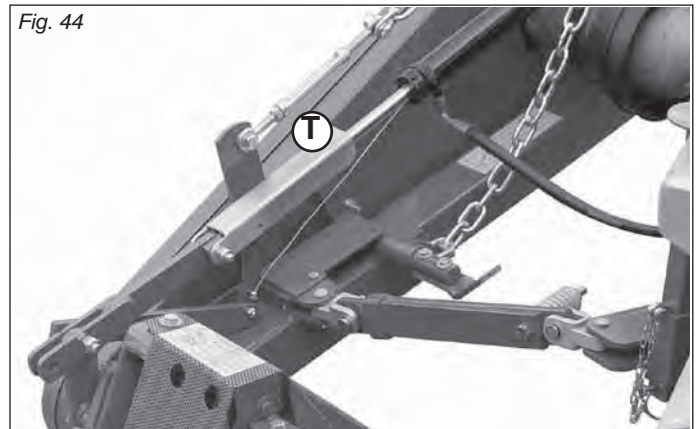

Raising of the cutter bar for road transport

- Fit the guards over the cutters and outer skid (C Fig. 60).
- From the tractor, pull the rope (S, Fig. 45) to disable the bracket (T, Fig. 45) and operate the hydraulic distributor to fully raise the cutter bar.
- Secure it with the hooking tie rod.

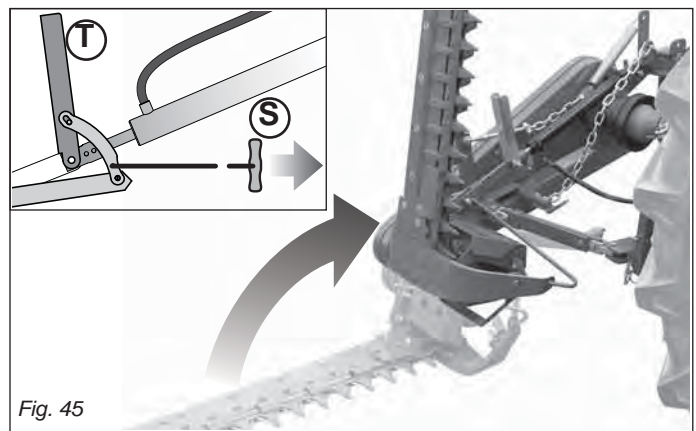

OPERATING - HYDRAULIC LIFTING SYSTEM

Mowing on flat ground (or ground with small depressions)

For mowing operations on level ground, couple the lever mechanisms (V and Z, Fig. 46) in position (X, Fig. 46).

Lastly insert the lifting device as described in the previous paragraph.

With the rapid lifting device engaged, the bar (U, Fig. 47) has a negative inclination of -15° with respect to the horizontal plane during mowing, and a positive inclination that varies according to the lie of the land.

This system has been devised for mowing quickly and safely on flat ground or ground with small depressions.

The operation of the lifting device up to the stop of the bracket on the cylinder (T, Fig. 48) allows the equipment to be raised by approx. 12.5 inches from the ground and, at the same time, an inclination of the blade (U, Fig. 48) of $+25^\circ$, so that the end of field maneuvers can be carried out.

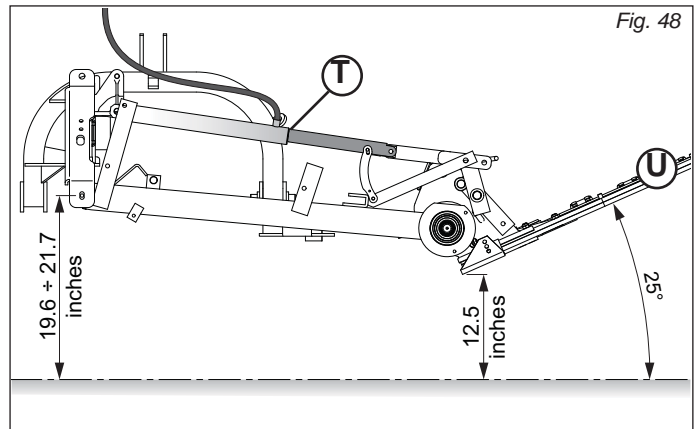
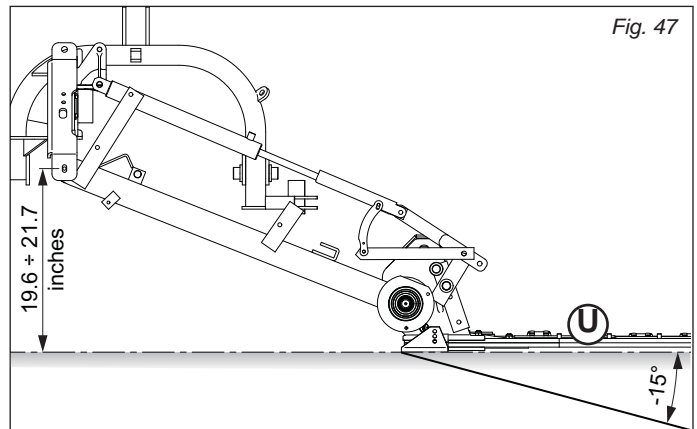
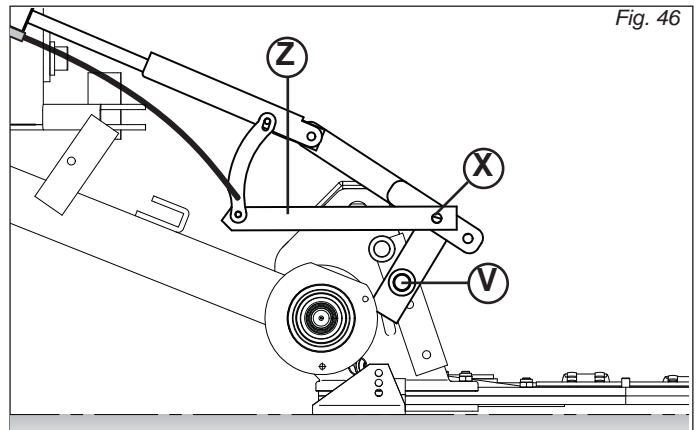

OPERATING - HYDRAULIC LIFTING SYSTEM

Mowing on slopes

Figure 49 show type of mowing on sloping ground (banks, canals, etc.).

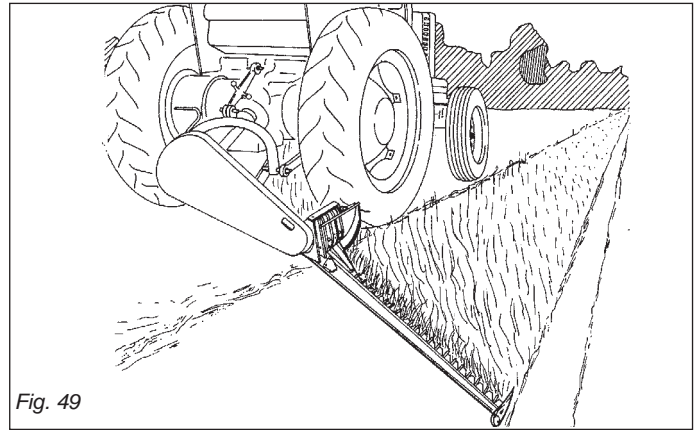

CAUTION: For mowing on surfaces that are not parallel to the tractor plane, we recommend removing the moving guide from the outer mowing bar support.

To mount pulling of Figure 50 in order to improve the excursion and use of the sickle bar.

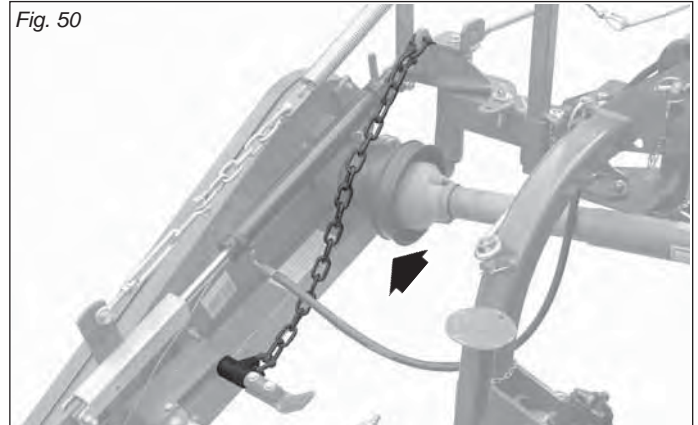

Only for mowing on sloping ground, it is necessary to prepare the machine according to the instructions given below:

- 1) Move the lever mechanisms (V and Z, Fig. 51) to position (Y).
- 2) Lift the bracket (T) as shown in Figure 51, and lock it with the rod (W) in the lower position of the slot (ref. W1, Fig. 51).
- 3) To avoid unpleasant problems during movement of the cutter bar, detach the steel cable (S) from the rod (W) and retrieve it up to position (S1) .

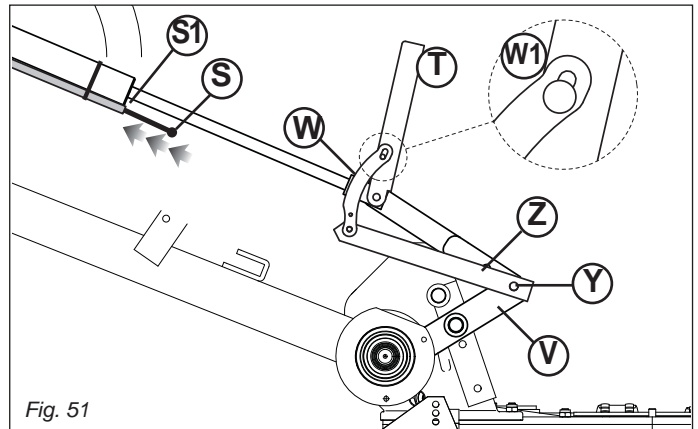

In this way the bar can be adjusted with the hydraulic cylinder to mow at different angles: from -45° to $+90^\circ$ with respect to the horizontal plane formed by the tractor (Fig. 52).

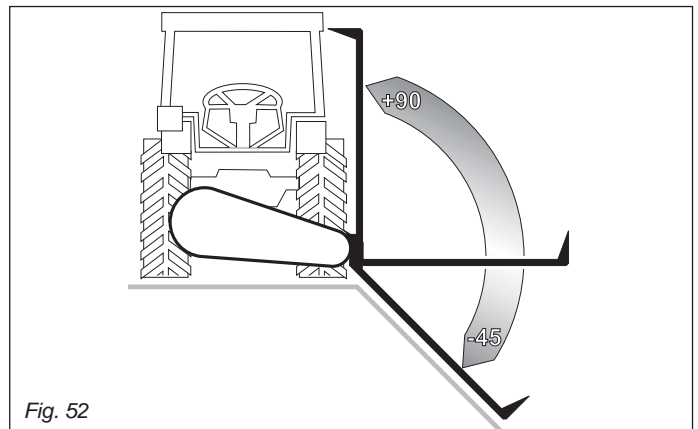

IMPORTANT:

The sickle bar can operate in each position between -45° to $+90^\circ$.

OPERATING - QUICK COUPLER

Quick Coupler

The Quick Coupler must be used only with hydraulic lifting system.

- 1) Install hitch Quick Coupler (A, Fig. 53) on the tractor (see tractor operator manual).
- 2) Parking the sickle bar on a flat and compact ground supported by the relative supports. Then slowly move the tractor back until the Quick Coupler (A) is in range with the point hitches (B and C, Fig. 53).
- 3) Raise the Quick Coupler (A, Fig. 53) and make sure that sickle bar hitch is in the right position (E, Fig. 54).

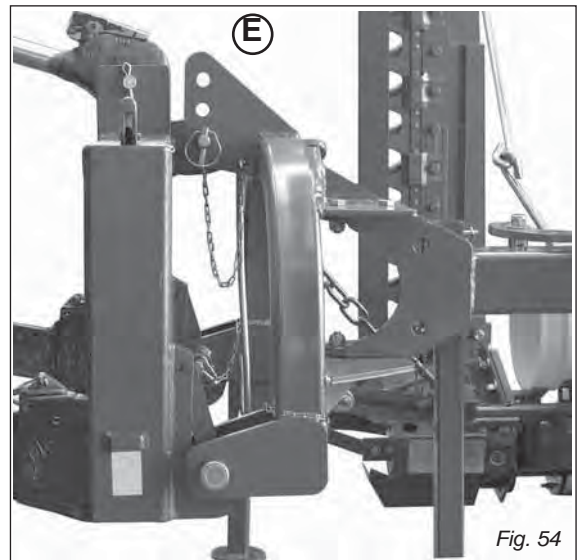
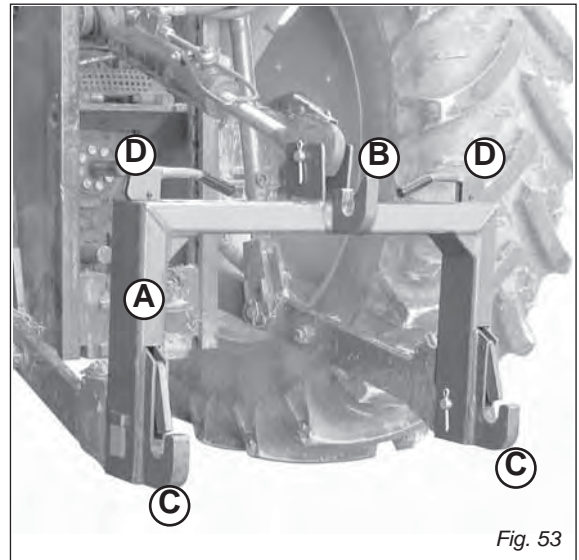

CAUTION: Before you work around hitch:

- STOP engine.
- LOCK park brake.
- FIRMLY block mower on horizontal surface.

Removing sickle bar mower with Quick Coupler

1. Raise sickle bar.
2. Put parking stand (F and G, Fig. 55) in the DOWN position: install spring locking pin in order to secure parking stand (H, Fig. 55).
3. Lower sickle bar to the ground.
4. Raise the two Quick Coupler levers (D, Fig. 53) to unloch sickle bar.
5. Lower Quick Coupler till further free the sickle bar.

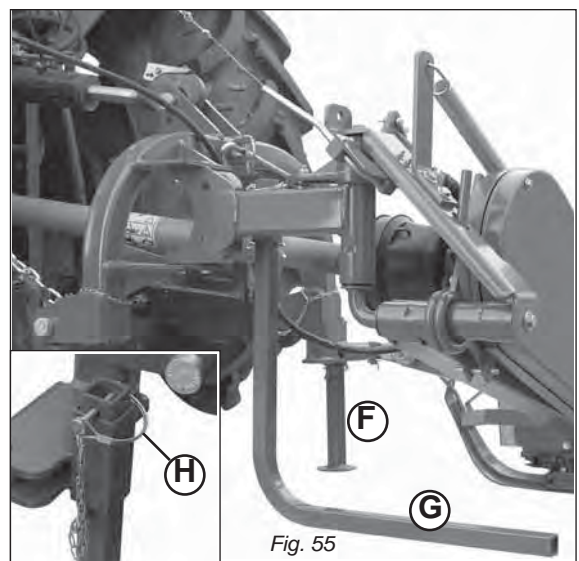

OPERATING

How to choose between sickle bars

TYPE OF THE GROUND		TYPE OF THE FORAGE			
		Dry and lignificated (gramineae)	Humid, packed and low (cat coat)	Humid and packed (Lucerne-Clover)	Big and high (forage of the sorghum, corn)
Level	Normal	DSE - SD/SN	DSE - SD	DSE - SN	DSE - SN
	Stny field	DSE - SD/SN	DSE - SD	DSE - SN	DSE - SN
Hill	Normal	DSE - SD/SN	DSE - SD	DSE - SN	DSE - SN
	Stny field	DSE - SD/SN	DSE - SD	DSE - SN	DSE - SN
Mountain	Normal	DSE - SD/SN	DSE - SD	DSE - SN	DSE - SN
	Stny field	DSE - SD/SN	DSE - SD	DSE - SN	DSE - SN

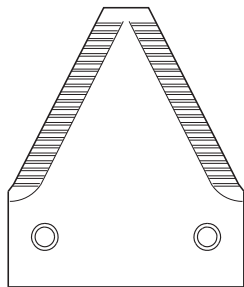

Normal Section (SN)

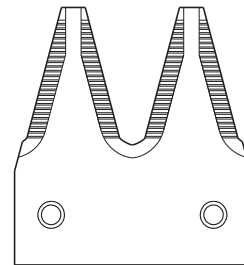

Self sharpening double section (SD)

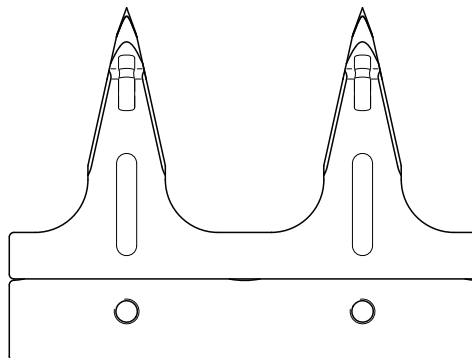

Replaceable Tooth (DSE)

SERVICE MACHINE SAFETY

Practice safe maintenance

- Understand service procedure before doing work. Keep area clean and dry. To avoid ...
- Never lubricate, service, or adjust machine while it is moving. Keep safety devices in place and in working condition. Keep hardware tight.
- To prevent from getting caught, keep hands, feet, clothing, jewelry, and long hair away from any moving parts.
- Before servicing machine, lower it to the ground. Disengage all power and stop the vehicle engine. Lock vehicle park brake and remove the key.
- Securely support any machine elements that must be raised for maintenance.
- Keep all parts in good condition and properly installed. Fix damage immediately. Replace worn or broken parts. Remove any buildup of grease, oil, or debris.
- Unauthorized modifications to the machine may impair its function and safety.



Wear appropriate clothing

- Wear close fitting clothing and safety equipment appropriate for the job.
- Loud noise can cause impairment or loss of hearing, wear a suitable protective device such as earplugs.
- Do not wear radio or music headphones while servicing the machine. Safe servicing requires your full attention.



Stay clear of rotating PTO shaft

Entanglement in rotating driveline can cause serious injury or death:

- Stop the engine and be sure PTO shaft is stopped before getting near it.



Maintenance

Various servicing operations are listed in the following paragraphs. Lower running costs and longer machine life depend on constant and methodical compliance with these operations.

During work and maintenance operations, use suitable personal protective gear:



CAUTION

- **The given frequencies are indicative and refer to normal conditions of use. They may therefore be subject to variations in relation to the type of service, a more or less dusty environment, seasonal factors, etc.**
- **In the case of heavy-duty conditions, the maintenance operations should obviously be more frequent.**
- **Before injecting grease into the lubricators, the greasing points must be thoroughly cleaned to prevent mud, dust or foreign bodies from mixing with the lubricant, thus reducing lubricating effect.**



ATTENTION

It is absolutely essential to disengage the tractor pto, lower the mowing machine, switch off the tractor, ensure that this is at a complete standstill and remove the key before servicing, adjusting the implement for work. All assembly operations must be carried out on a work bench.

- **Always keep oils and greases well away from children's reach.**
- **Always thoroughly read the warnings and precautions indicated on the containers.**
- **Avoid contact with the skin.**
- **Always thoroughly and fully wash after use.**
- **The utilized oils should be treated in compliance with the current laws in force.**

SERVICE MACHINE SAFETY

- Do not proceed with maintenance and cleaning if the power take-off has not been disconnected first, the engine power off, the hand brake pulled and the tractor blocked with a wooden block or stone of the right size under the wheels.
- Periodically check that the bolts and nuts are tight, and if necessary tighten them again. For this it would be advisable to use a torque wrench, respecting the values of 52 Nm for M10 bolts, resistance class 8.8, and 143 Nm for M14 bolts resistance class 8.8 (Table 1: **Bolts tightening torques**).
- During assembling, maintenance, cleaning, fitting, etc., with the mowing machine raised, place adequate supports under the equipment as a precaution.
- The spare parts must correspond to the manufacturer's specifications. **Use only original spares.**

Bolts tightening torques - settings given in Nm (lb-ft)

(Table 1)

Fine pitch screws (metric)	CLASS			
	6.6	8.8	10.9	12.9
M8 x 1	15 (11)	26 (19)	36 (26.5)	44 (32.5)
M10 x 1.25	30 (22)	52 (38)	74 (54)	88 (65)
M12 x 1.25	51 (37.5)	91 (67)	127 (94)	153 (113)
M14 x 1.5	81 (60)	143 (105)	201 (148)	241 (178)
M16 x 1.5	120 (88)	214 (158)	301 (222)	361 (266)
M18 x 1.5	173 (127)	308 (227)	433 (319)	520 (384)
M20 x 1.5	242 (178)	431 (318)	606 (447)	727 (536)
M22 x 1.5	321 (237)	571 (421)	803 (592)	964 (711)
M24 x 2	411 (303)	731 (539)	1028 (758)	1234 (910)
M27 x 2	601 (443)	1070 (790)	1504 (1110)	1806 (1333)
M30 x 2	832 (614)	1480 (1090)	2081 (1535)	2498 (1843)

Hazard bar

The hazard bar has been included with the equipment of the machine for safety reasons, to indicate the space occupied by the mower at work. For working, position the hazard bar in position (A1, Fig. 56) and lock it in place with the screw (B). For transport put it in position (A2).

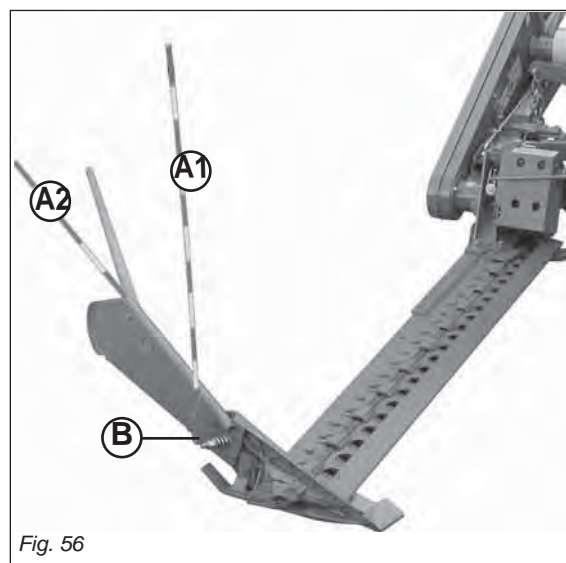

Lubrication



- WARNING:**
- Firmly block sickle bar on horizontal surface.
 - Always keep oils and greases well away from children's reach.
 - Always thoroughly read the warnings and precautions indicated on the containers. Avoid contact with the skin.
 - Always thoroughly and fully wash after use. The utilized oils should be treated in compliance with the current anti-pollution laws.

Routine maintenance

- During the first working hours, check that the screws are tight (Fig. 60).

Every 2 work hours

- Grease point (A and C, Fig. 57).

Wear-proof skids (optional)

In the presence of abrasive terrain (rocky, sandy, etc.) wear-proof skids can be provided on request to protect the cutterbar.

External wear-proof skids are available in all versions (D-E, Fig 58), whereas, the central wear-proof skid is also applied only in the versions with a cutting width of L. 2.05 and L. 2.35 (F, Fig 58).

They can be adjusted in 3 different positions to obtain 3 different cutting heights.

It is important to set all the wear-proof skids to the same position, which corresponds to the same cutting height. When adjusting the central wear-proof skid, pay utmost attention to the precise mounting of the adjustment deflector to obtain the correct cutting height.

Every 8 work hours

- Grease the cardan shaft and its telescoping parts.
- Adjust belt tension periodically by adjusting nut (G, Fig. 59). Check tension via the viewing panel on the belt guard. Belt slack must not exceed 1 inch. It is essential to close the inspection hatch with the relative lid after the belts have been examined.

Every 50 work hours

- Check the tightness of the connecting rod bolts regularly (Fig. 60).
- Checking the clearance tolerance.

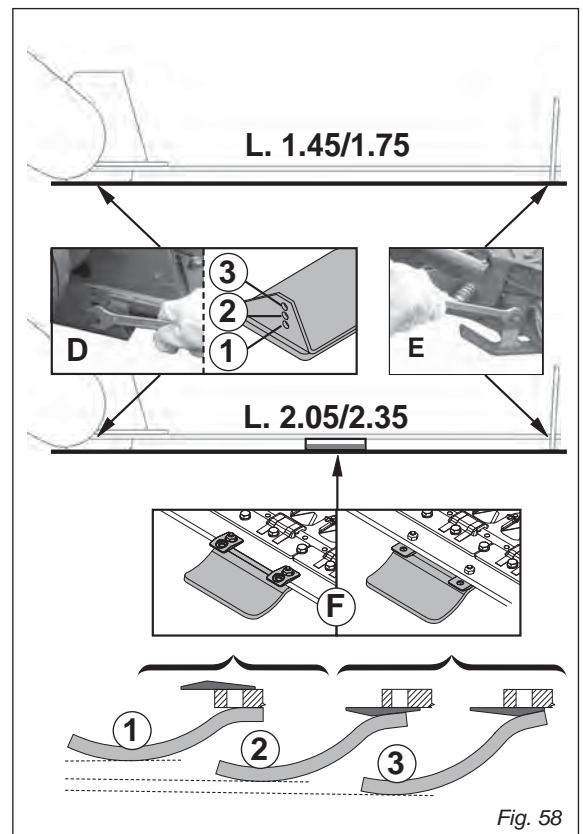
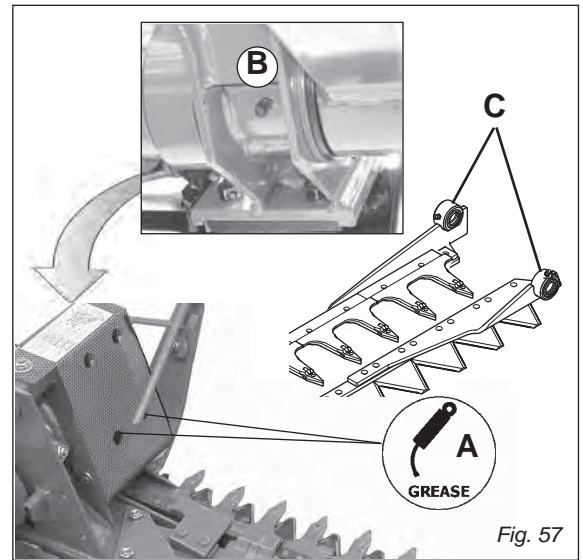

SERVICE

Periodically (6 months)

- Grease point (B, Fig. 57).

After each mowing

- Clean and oil the mowing bar blades according to the instructions in the chapter entitled: "Cleaning and oiling the cutters".

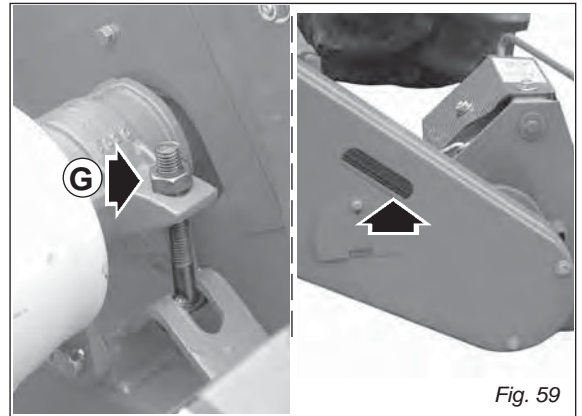

Lubricants

- It is advisable to use **SAE 85W/140 OIL** or equivalent for the reduction unit (or gear box) and side transmission.
- It is advisable to use **GR MU EP 2 GREASE** or equivalent for all greasing points.

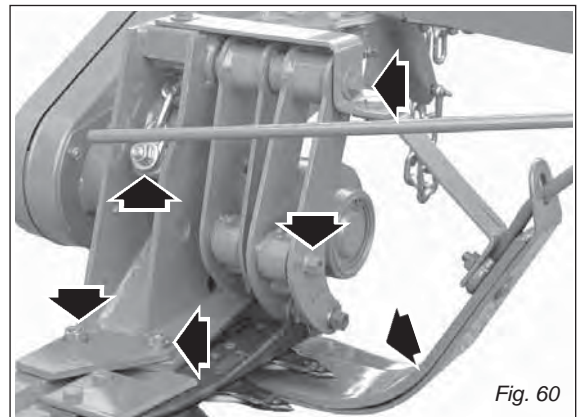

Cleaning and oiling the sickle bar

DANGER

Cleaning and oiling are very dangerous operations. Always comply with the following instructions:

- Lift the implement by means of the lift links in a flat place where it cannot slip;
- Operate the mowing bar, checking that there are no persons or animals in the vicinity;
- Brake the tractor and make sure it is unable to move;
- **Wash the sickle bar with a jet of pressurized water, standing at least one and a half meters away from the implement;**
- Switch off the tractor, remove the starter key and disengage the pto;
- Check the condition of the cutters;
- **When the mowing bar is dry, lubricate the cutting blades with very viscous oil;**
- Operate the sickle bar for a few seconds, checking that there are no persons or animals in the vicinity;
- Switch off the tractor, remove the starter key and disengage the pto;
- Fit the guards over the cutters and outer skid (C, Fig. 61).

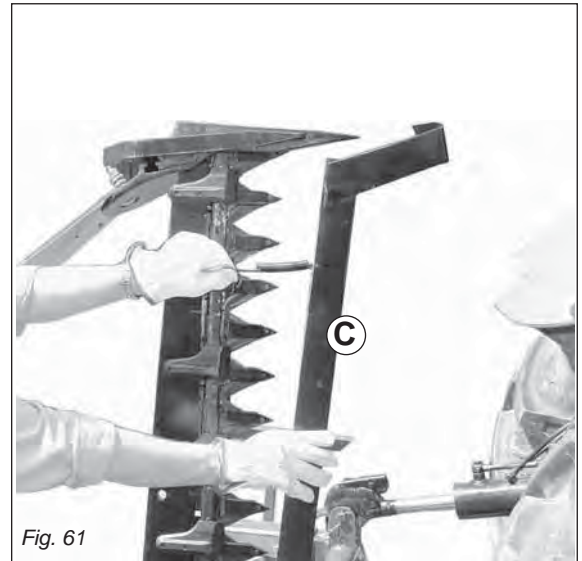

IMPORTANT! The cutting blades must be cleaned and lubricated every day after work.

Storage

It is advisable to proceed in the following way at the end of the season or if the machine is to remain inactive for a long period of time:

- Treat the implement in compliance with the instructions given in the chapter entitled: **“Cleaning and oiling the cutters”**.
- Carefully check for any damaged or worn parts and replace these as necessary.
- Fully torque all screws and bolts.
- Apply a little lubricant to the unpainted parts.
- Protect the entire implement with a cover.
- Lastly, store the implement in a dry place where it cannot be tampered with by unauthorized persons; the mowing machine must be set-up on flat and compact ground, supported by the relative supports (H and I, Fig. 62).

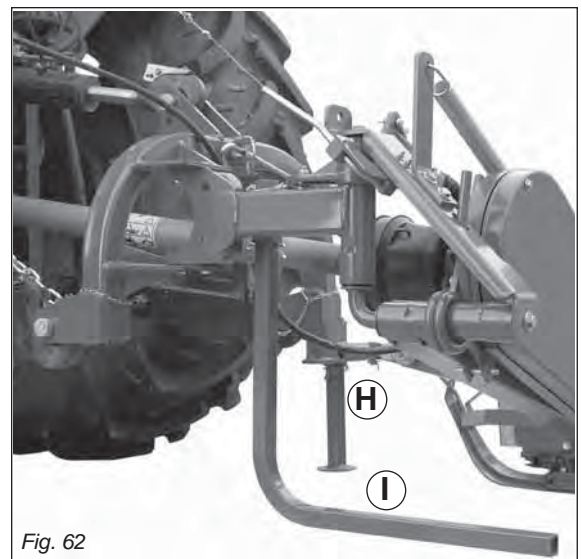

Careful compliance with these instructions will be all to the advantage of the user who will be sure to use an implement in perfect conditions when work begins again.

Checking the clearance tolerance



ATTENTION

It is absolutely essential to disengage the tractor pto, lower the mowing machine, switch off the tractor, ensure that this is at a complete standstill and remove the key before servicing, adjusting the implement for work. All assembly operations must be carried out on a work bench.

Before activating the mower, one must periodically check that the blade holder rod (M, Fig. 63) and the upper blade guides (N) are coupled properly.

After many hours of work, wear of the blade guide material may be seen, and this will cause an increase in the coupling tolerance with the tooth blade.

An excessive coupling tolerance between the parts results in material entering between the same, causing likely breakage of the cutting blades or parts of them, also compromising the quality of the cut.

In contrast, a reduced coupling tolerance generates a strong sliding friction of the blade with consequent breakage of the blade holder rod, the blade head or other elements of the hinge (connecting-rod assembly).

It is therefore advisable to restore the correct tolerance!

The check must be carried out on all blade guides (Fig. 65) using a ~0.04 inches (1 mm) thick shim plate, supplied.

Always use personal protective equipment.

The tolerance allowed for optimal coupling is determined by the insertion of a single plate (Z1, Fig. 66).

If a plate does not fit between the teeth blade and the blade guide one must add a shim (Fig. 63-64);

If instead two coupled plates can be inserted (Z2, Fig. 66) one must remove a shim to restore the optimal coupling tolerance conditions.

CAUTION

When fitting the blade guide it is important to leave a coupling tolerance of about ~0.04 inches (1 mm) with the sections holder rod (L, Fig. 63).

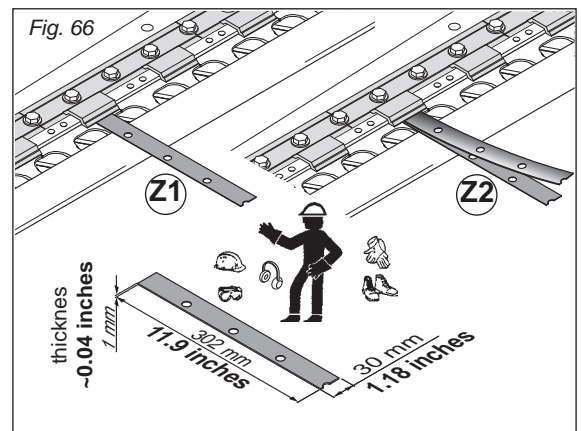
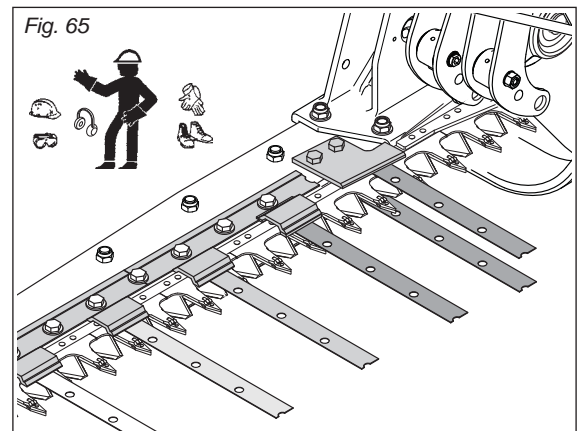
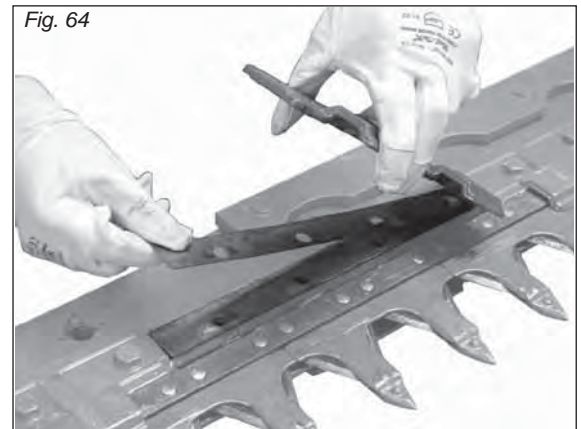
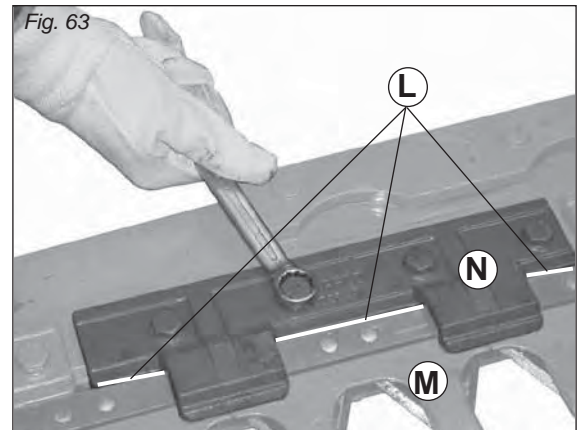

SERVICE

Only with some models, before disassembling the blade guides (N, Fig. 63), one must previously remove the finger blade tie rod (W) in Figure 67. Use a punch to facilitate the operation (T, Fig. 67).

Subsequently, only after having made sure that the blade guides have been blocked, one must tighten the finger blade again via the nuts, located at both ends, keeping to the 0.59 inches (15 mm) shown in Figure 67. Use a punch to facilitate the operation (T, Fig. 67)

This measurement allows to maintain the cutting bar in traction, without bending it downwards.

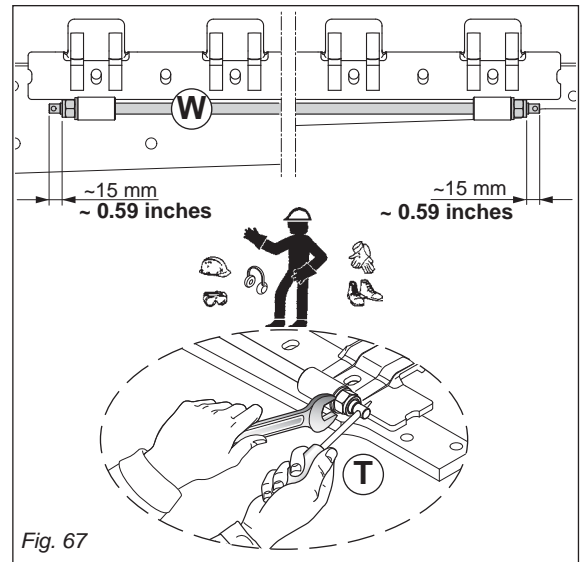

IMPORTANT: When replacing the teeth or the tooth-holding bar, carry out the check described above. When required, put back the shims to avoid striping or damage.

Extra maintenance

! ATTENTION
It is absolutely essential to disengage the tractor pto, lower the mowing machine, switch off the tractor, ensure that this is at a complete standstill and remove the key before servicing, adjusting the implement for work. All assembly operations must be carried out on a work bench.

During all maintenance operations on moving parts, it is important to grease all the points indicated in Figure 57 before starting the machine.

Replacing the cutting blades

! ATTENTION
The expansion pins must be reassembled as shown in Figure 68 (A), by tightening the screw and the conical nut with a torque not exceeding 30 Nm. Every time the expansion pins are disassembled and reassembled, one must grease the blade head concerned (C, Fig. 57).

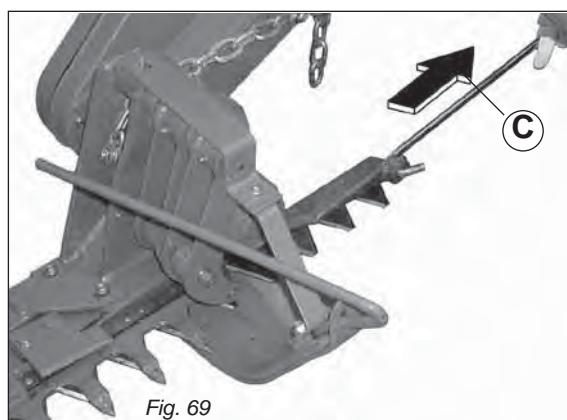
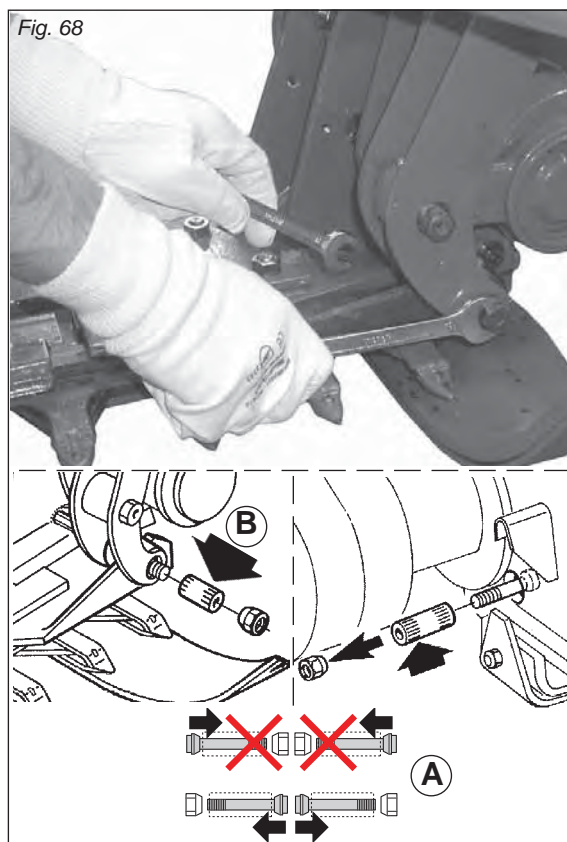

Replacement of section-holding bar (E, fig. 70)

- With the implement resting on the ground, open the mowing bar.
- Remove the expansion pin (B, Fig. 68) and pull out the section-holding bar (Fig. 69) with the hooking tie rod (C, Fig. 69).
- Insert the new section-holding bar and lock it in place with the expansion pin. Lubricate the cutters with very viscous oil during the assembly phase.

Replacement of sections (D, fig. 70)

- With the implement resting on the ground, open the mowing bar.
- Remove the expansion pin (B, Fig. 68) and slide out the section-holding bar (Fig. 69).
- Remove the damaged section using a pin punch (7, Fig. 4 on page 6).
- Rivet a new section with the rivets provided (D, Fig. 70).
- Insert the section-holding bar and lock it in place with the expansion pin.

SERVICE

Replacement of tooth-holding bar (riveted) (G Fig. 71)

- With the implement resting on the ground, open the mowing bar.
- Remove the expansion pin (B, Fig. 68) and slide out the toothholding bar (Fig. 69).
- Insert the new tooth-holding bar and lock it in place with the expansion pin.

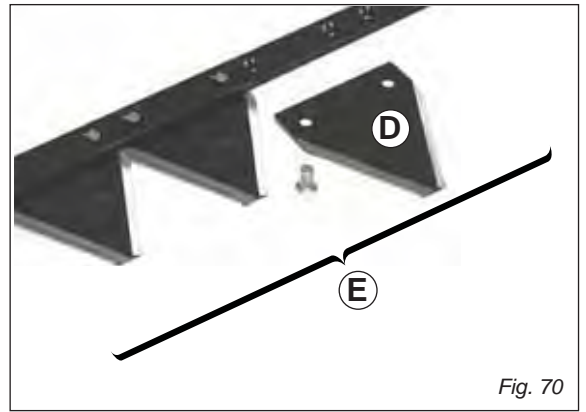

Fig. 70

Replacement of tooth (riveted) (F fig. 71)

- With the implement resting on the ground, open the mowing bar.
- Remove the expansion pin (B, Fig. 68) and slide out the toothholding bar (Fig. 69).
- Remove the damaged tooth using a pin punch.
- Rivet a new tooth with the rivets provided (F, Fig. 71).
- Insert the tooth-holding bar and lock it in place with the expansion pin.

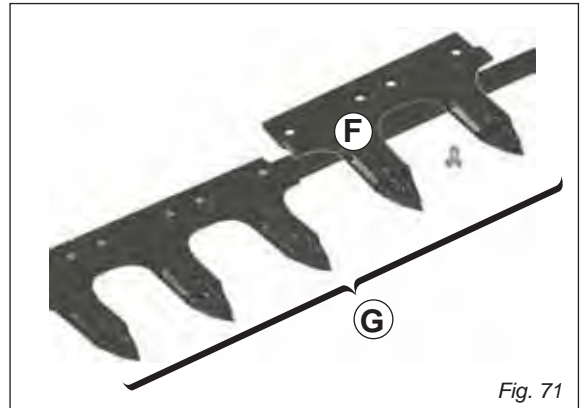

Fig. 71



ATTENTION

It is absolutely essential to disengage the tractor pto, lower the mowing machine, switch off the tractor, ensure that this is at a complete standstill and remove the key before servicing, adjusting the implement for work. All assembly operations must be carried out on a work bench.

Replacement of bar holding removable tooth

- With the implement resting on the ground, raise the mowing bar and secure it with the hooking tie rod.
- Unscrew all the tooth fastening screws (Fig. 72).
- Remove all the teeth (Fig. 73).
- Remove the expansion pin and slide out the bar.
- Insert the new tooth-holding bar and lock it in place with the expansion pin.
- Reposition the teeth by fixing them with new screws and washers.



Fig. 72

Replacement of removable tooth

- With the implement resting on the ground, raise the mowing bar and secure it with the hooking tie rod.
- Unscrew the screws of the tooth to be replaced (Fig. 72).
- Pull out the tooth (Fig. 73) and replace it with a new one, blocking it with new screws and washers. For this it would be advisable to use a torque wrench, respecting the values of 30 Nm.



Fig. 73

Replacing the anti-vibration yokes

Dismantling

- Remove the protection.
- Remove the expansion pins (M, Fig. 74).
- Loosen and remove screws L, H, I (Fig. 74).
- Remove the support (N, Fig. 74).
- Remove the yokes (P, Fig. 74).

Assembly

- 1) Insert the new yokes with the intermediate spacer (O, Fig. 74).
 - 2) Refit the support and screws L, H, I without tightening them.
 - 3) Couple the yokes to the connecting rods and fasten them with the expansion pins.
 - 4) Align the yokes properly using a pin or screw (M20) (Fig. 74).
 - 5) Tighten screws H and I.
 - 6) Tighten screw L securely.
- CAUTION: do not tighten the screws without having aligned the yokes correctly (P, Fig. 75).
- 7) Refit the protection.

Verifying the assembly

The bolt must be removed manually with no force; if necessary, repeat the tightening steps of screws "H", "I" and then "L".

Replacement of belts

- Unscrew the screws (Q, Fig. 76) and remove the protective casing.
- Loosen the belt tensioner completely (R, Fig. 76).
- Replace the worn belts with new ones.
- Put these at the optimum tension using the belt tensioner. Belt play should not exceed 1 inch.
- Put the protective casing back in position and fix it in place with the screws (Q, Fig. 76).

Replacement of pulleys

Notes for replacement of pulleys, if necessary.

- Unscrew the screws (Q, Fig. 76) and remove the protective casing.
- Loosen the belt tensioner completely (R, Fig. 76).
- Remove the belts.

To replace the driving pulley (S, Fig. 77), turn it clockwise; viceversa, turn the driven pulley (T, Fig. 77) counterclockwise.

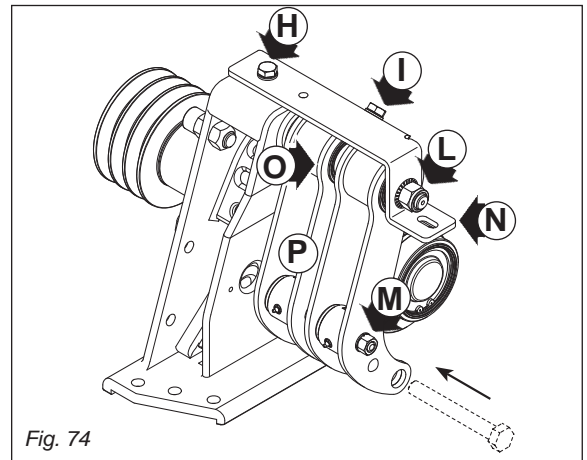

Fig. 74

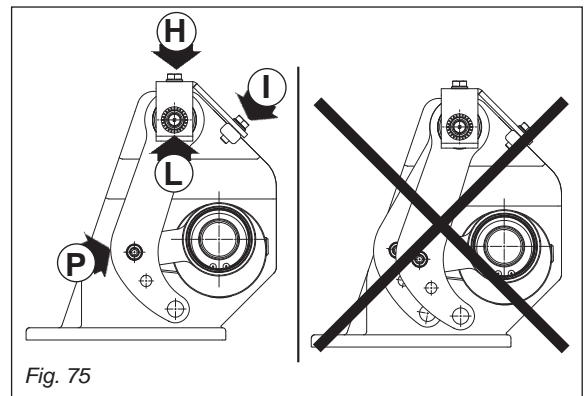

Fig. 75

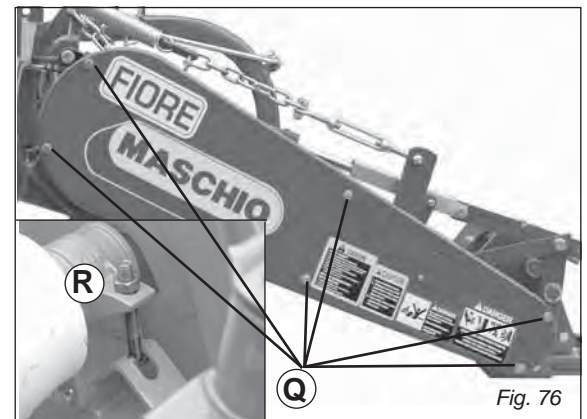

Fig. 76

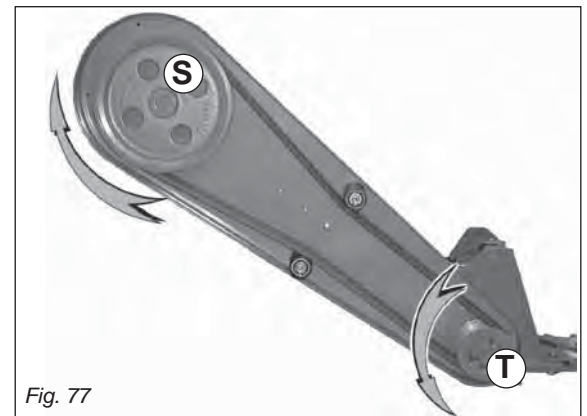
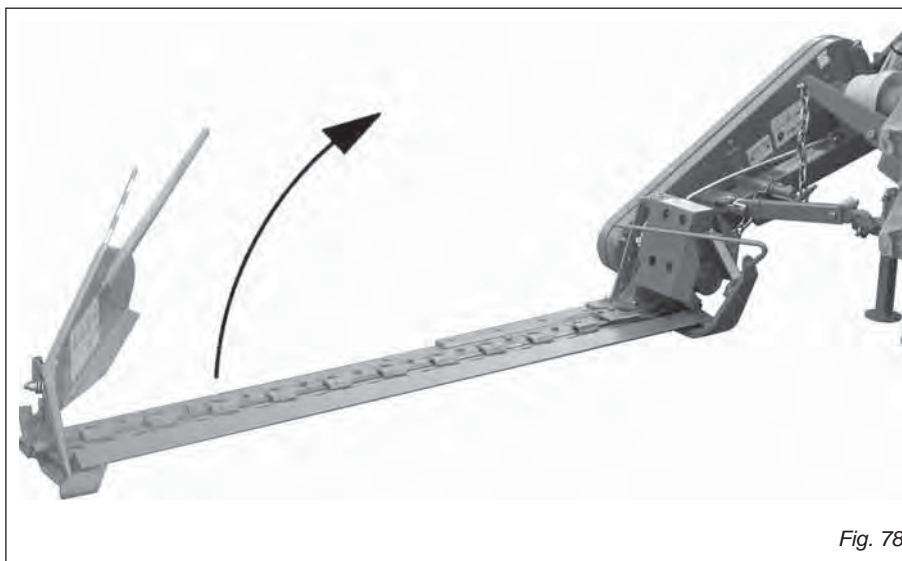

Fig. 77

TRANSPORT ON THE ROAD

Transport on road



For transport, adjust and fix the chains of the side lifting arms of the tractor; lift the mowing bar (Fig. 78); secure it with the hooking tie rod (A, Fig. 79); slide in the safety hook (B, Fig. 79); cover the cutting blades and the outer mowing bar support with the guards provided (Fig. 80); lift the implement; put the hydraulic lifting command lever in the locked position.

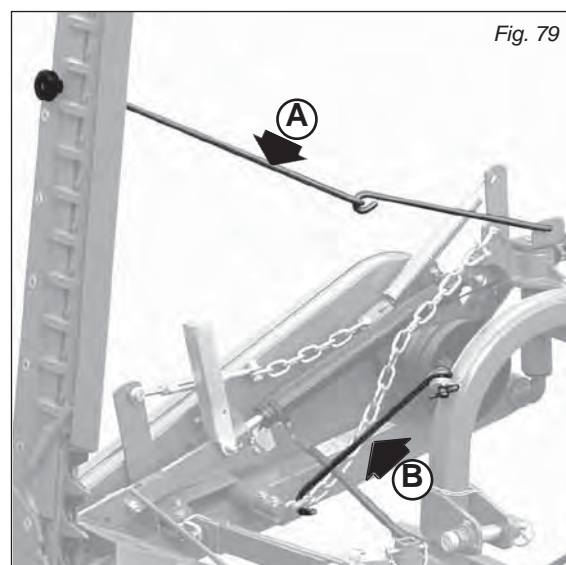

Transport on Road

- When driving on public roads, be sure to follow the highway code of the country involved.
- Any transport accessories must be provided with suitable signs and guards.
- It is very important to remember that road holding capacity as well as direction and braking capacity can be influenced, sometimes considerably, by equipment being either carried or towed.
- When negotiating curves, be aware of the variation in centrifugal force exerted in a position other than that of the center of gravity, with and without the equipment in tow. Also pay greater attention on sloping roads or ground.
- For displacements beyond the work area, the equipment must be placed in the transportation position.
- When the dimensions of carried or partially-carried equipment conceal the tractor's signalling and lighting devices, these must also be installed on the equipment itself, in conformity with regulations of the highway code of the country involved. When in operation make sure that the lighting system is in perfect working order.

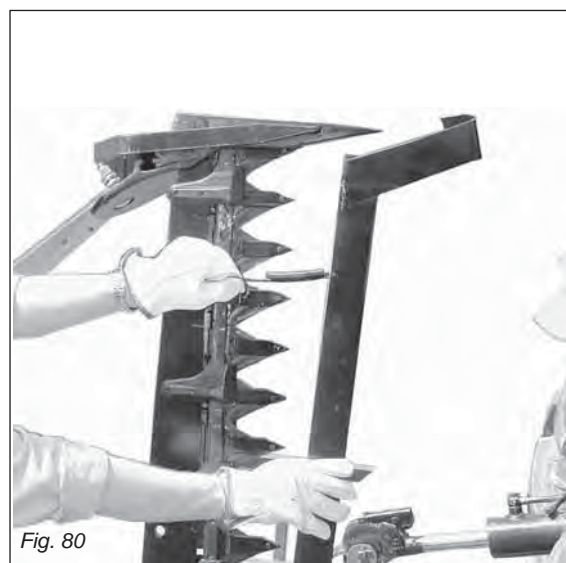

DEMOLITION AND DISPOSAL

Demolition and disposal

This operation is to be carried out by the customer.

Before demolishing the machine, you are advised to carefully check its physical condition and ascertain whether there are any parts of the structure that may be susceptible to structural collapse or breakage during demolition.

The customer should operate in compliance with the environment protection laws in force in his/her country.



CAUTION

The machine demolition operations should be carried out by skilled personnel only, equipped with suitable protective clothing (safety footwear and gloves) and auxiliary tools and equipment. All the disassembly operations for demolition should be carried out with the machine stopped and detached from the tractor.

Before demolishing the machine, you are advised to render harmless all the parts that may be a source of danger and therefore:

- scrap the structure using specialized firms,
- remove any electrical apparatus according to the laws in force,
- collect oils and greases separately, to be disposed of through specialized firms, in accordance with the regulations of the country in which the machine was used.

When the machine is demolished the identification label must be destroyed together with this manual.

ASSEMBLY

Foreword

This chapter describes the phases involved in assembling a crated mower. When handling and assembling the unit, and subsequently during use and maintenance, always use suitable personal protection devices (A): always wear suitable clothing and the indicated protections. See the operating manual supplied with the unit for indication of the symbols used in this manual. When handling the unit, lift it by hooking up the special attachments and using a suitable hoist or crane rated for the weight of the unit. This operation is quite dangerous and must only be performed by prepared, responsible personnel. The machine weight is indicated on the ID label. The hook-up points are identified by the “hook” symbol (B). When moving the unit, make certain that all protections and safety devices are in place.



Dimensions and weight

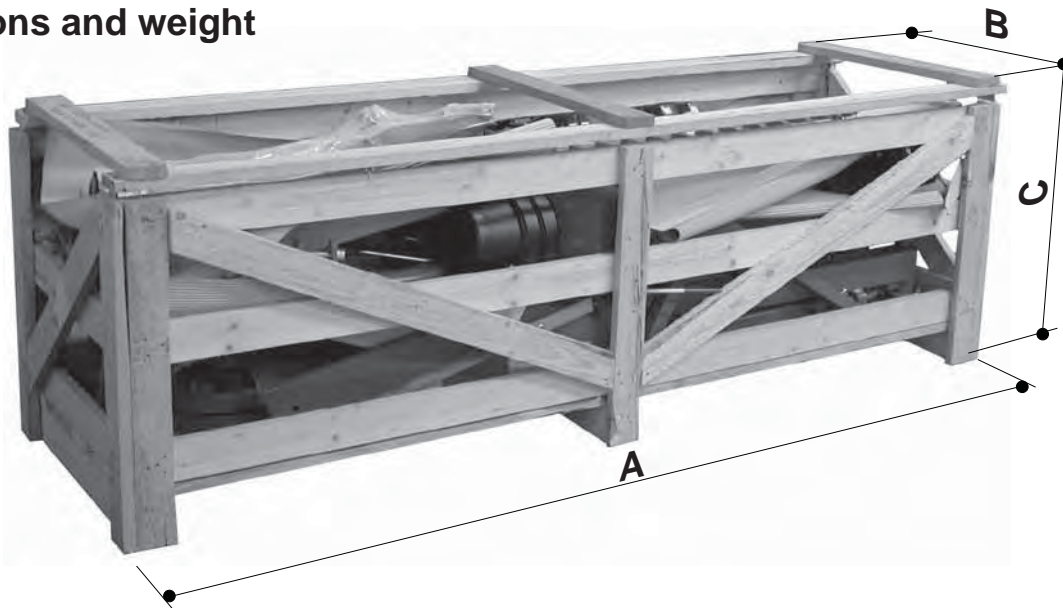

TYPE	A (cm - inch)	B (cm - inch)	C (cm - inch)	 (kg - lb)
FIORE 175 (X2)	234 - 92	70 - 27.5	74 - 29	520 - 1145
FIORE 205 (X2)	234 - 92	70 - 27.5	74 - 29	560 - 1235
FIORE 235 (X2)	275 - 108	73 - 28.7	72,5 - 28.5	600 - 1320
FIORE 175 (X5)	234 - 92	140 - 55	100 - 39	1200 - 2640
FIORE 205 (X5)	234 - 92	140 - 55	100 - 39	1300 - 2860
FIORE 235 (X5)	234 - 92	140 - 55	100 - 39	1400 - 3085

ASSEMBLY

Sickle bar components

- 1) THIRD POINT LINKAGE FRAME.
- 2) SIDE PROP.
- 3) POWER TAKE-OFF PLATE.
- 4) FRONT PLATE.
- 5) CUTTER BAR TIE-ROD.
- 6) REAR FRAME.
- 7) BLADE HOLDER.
- 8) MECHANICAL OR HYDRAULIC LIFT.

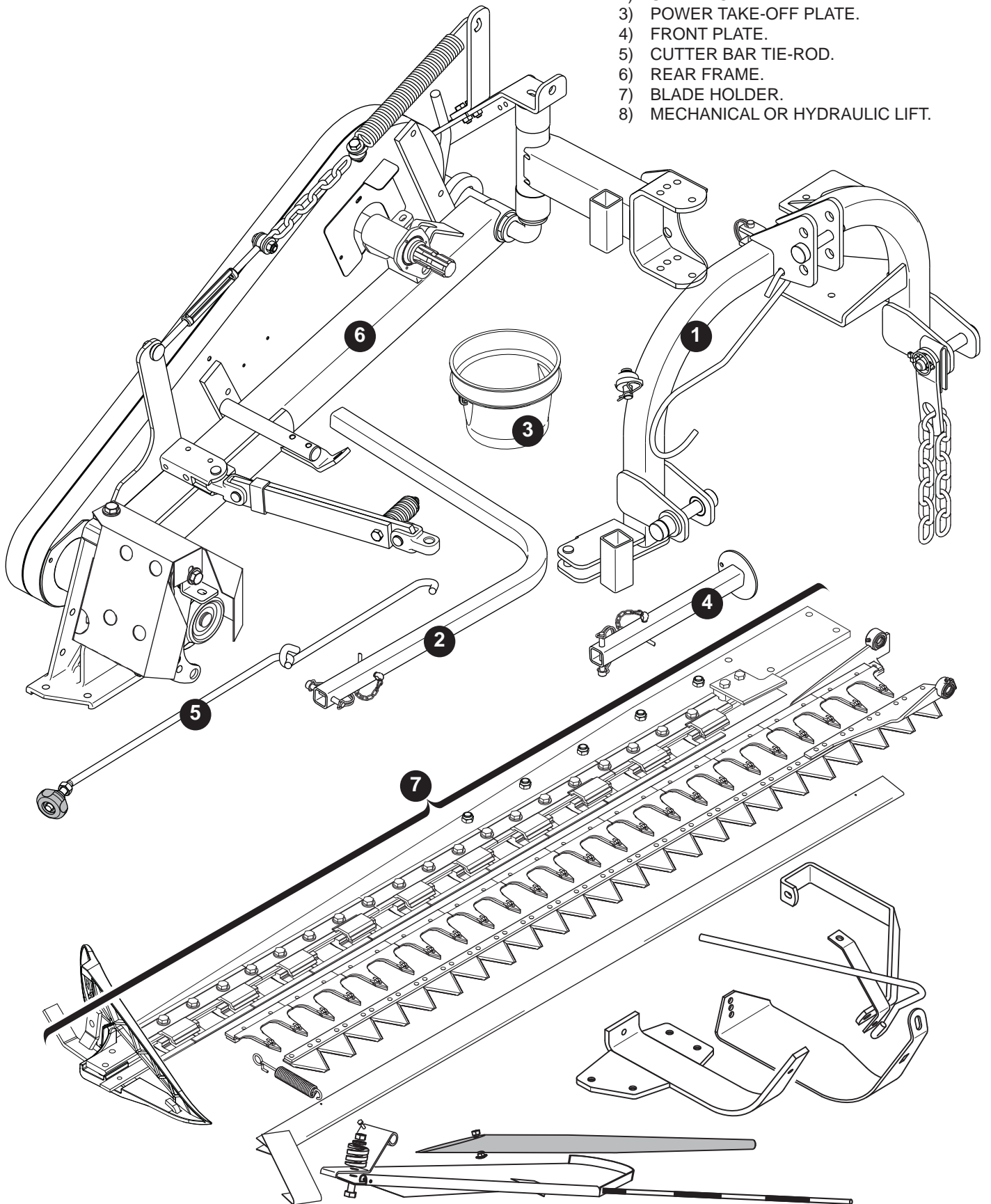

ASSEMBLY

Mechanical lifting

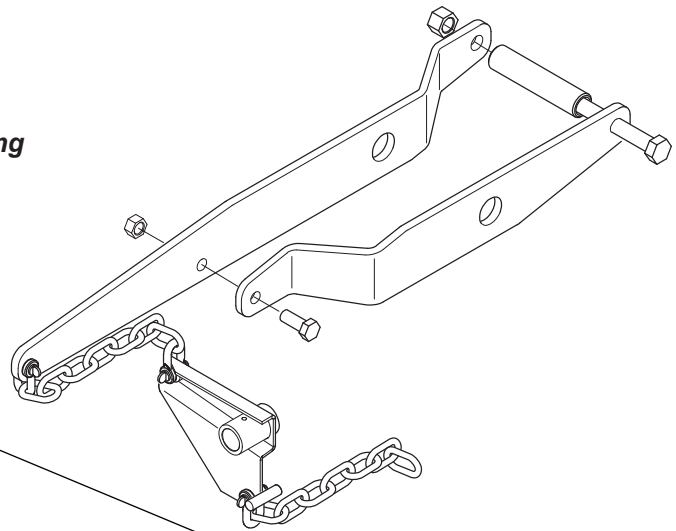

Hydraulic lifting

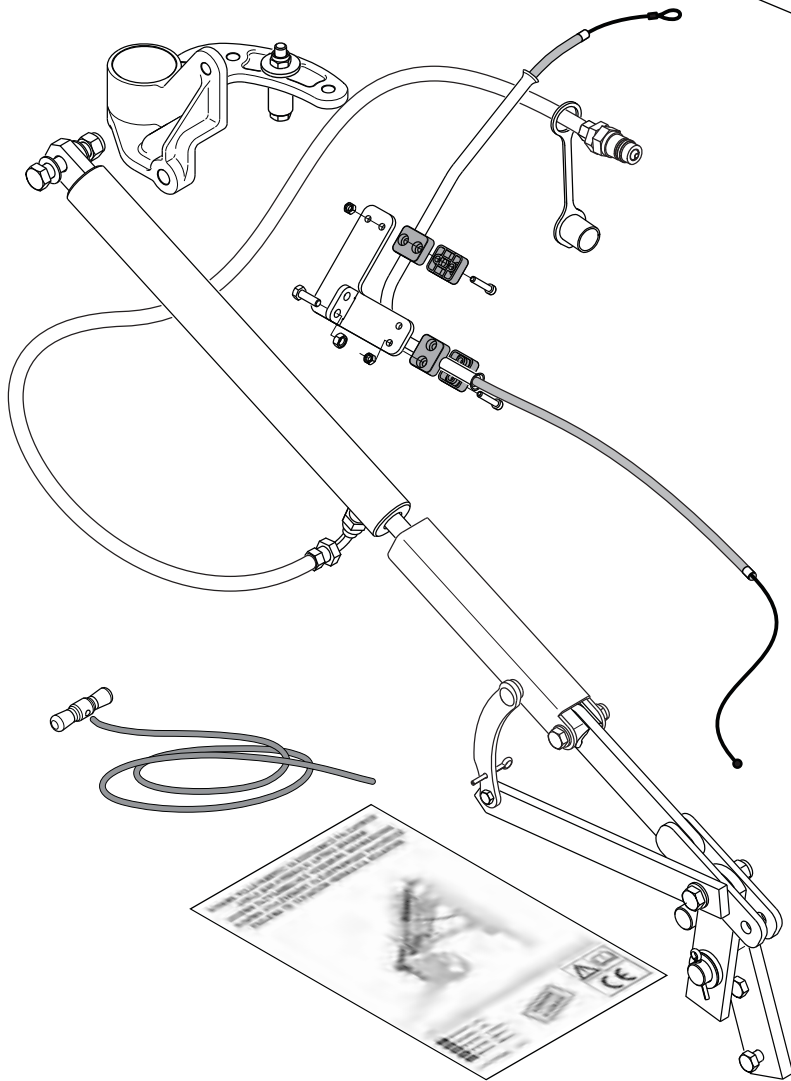

ASSEMBLY

1.0

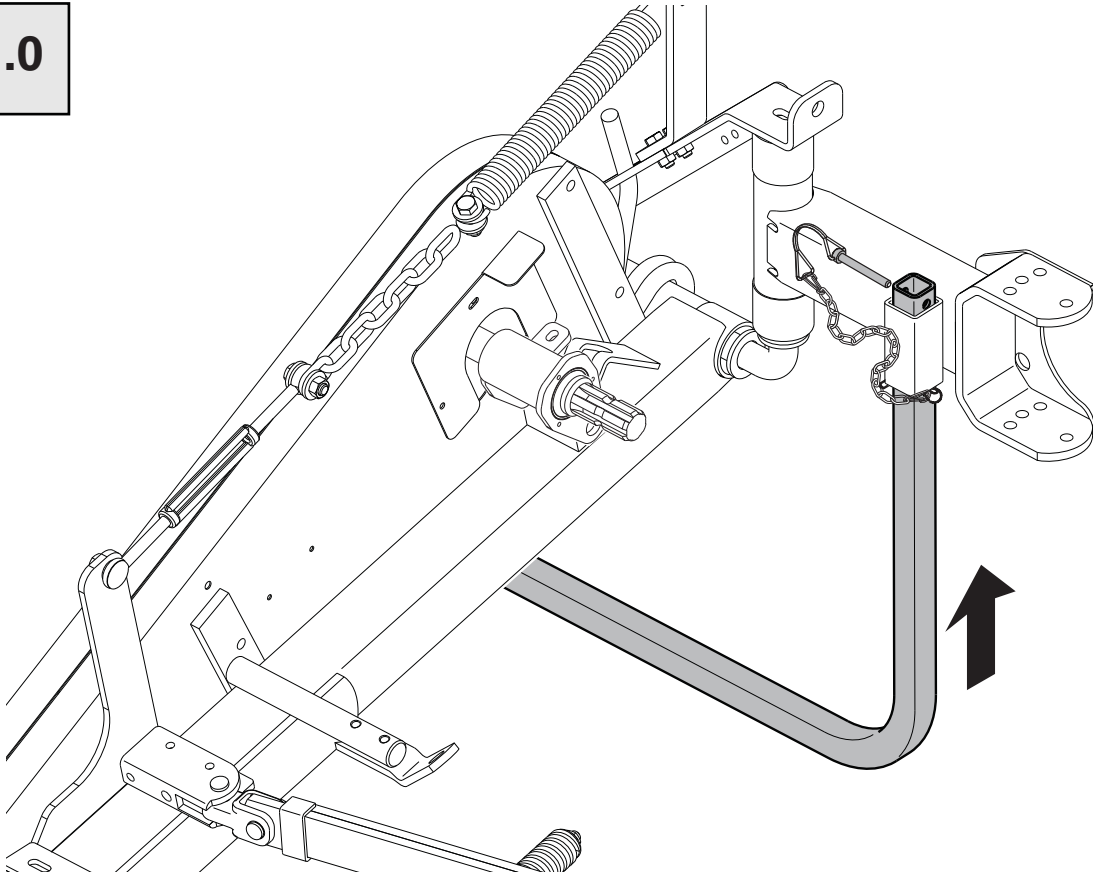

2.0

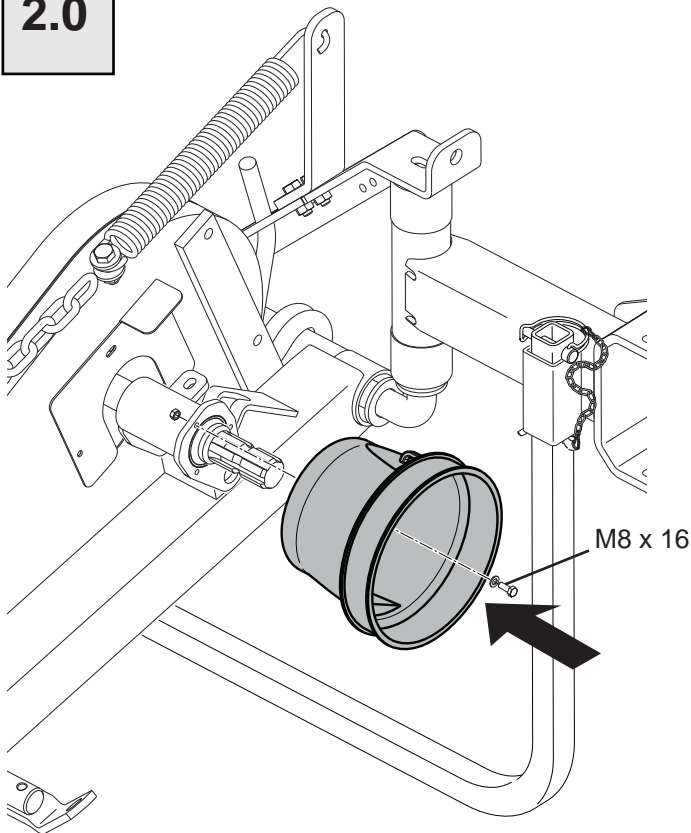

3.0

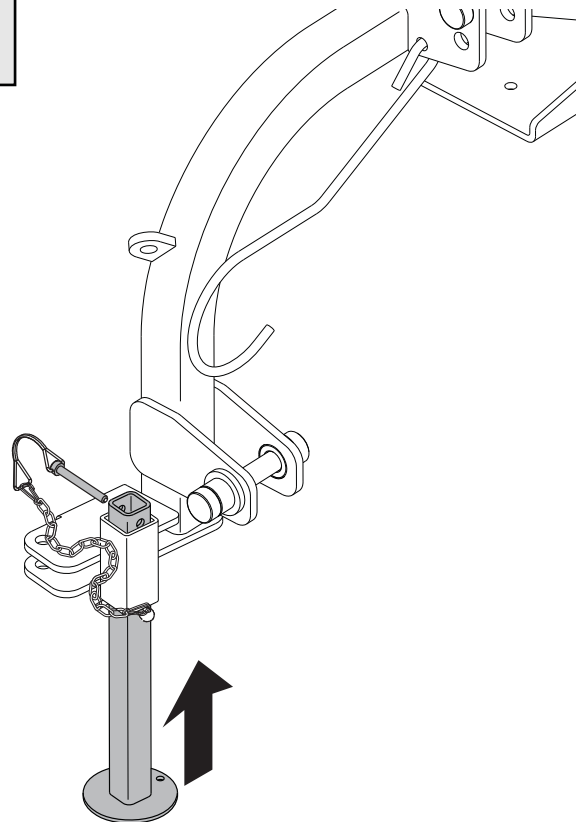

ASSEMBLY

4.0

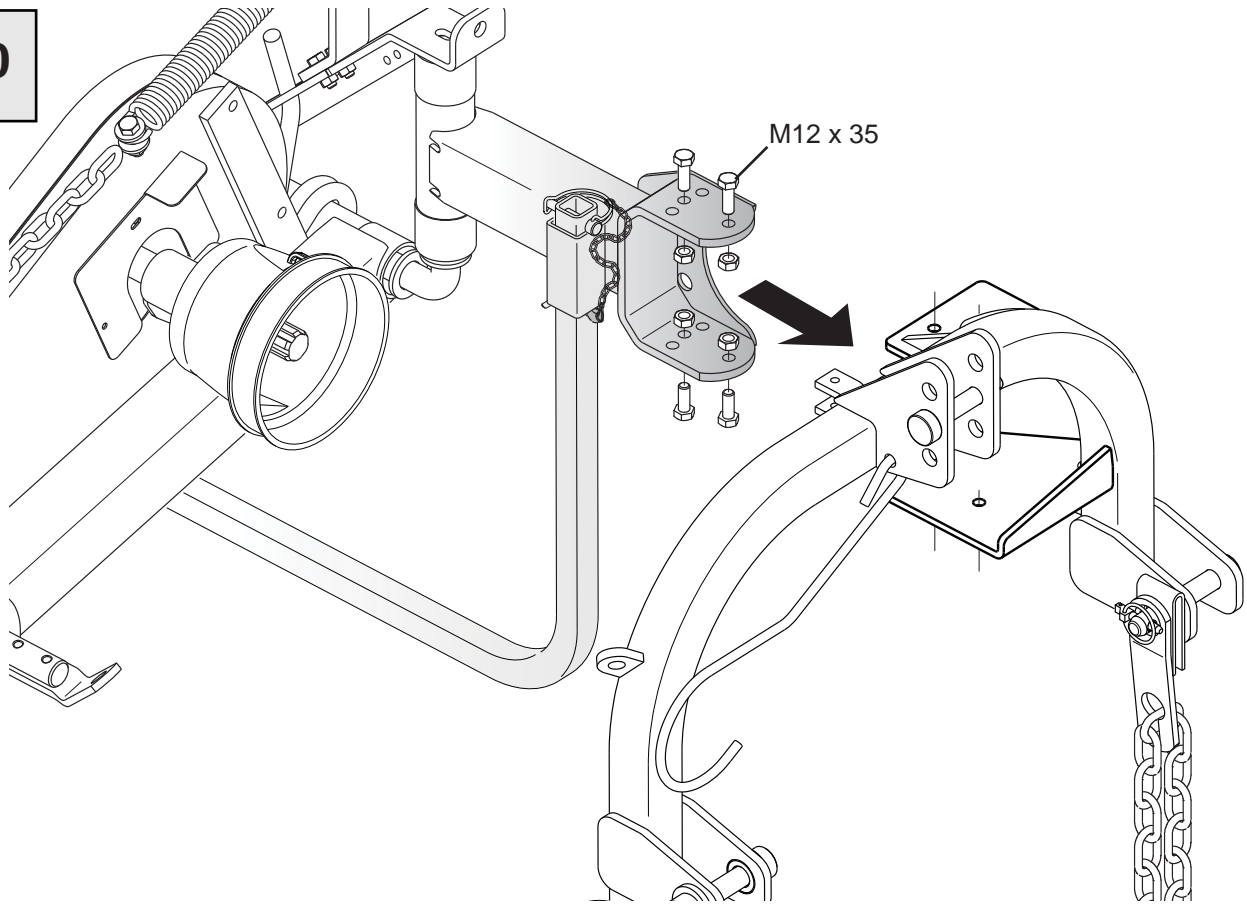

5.0

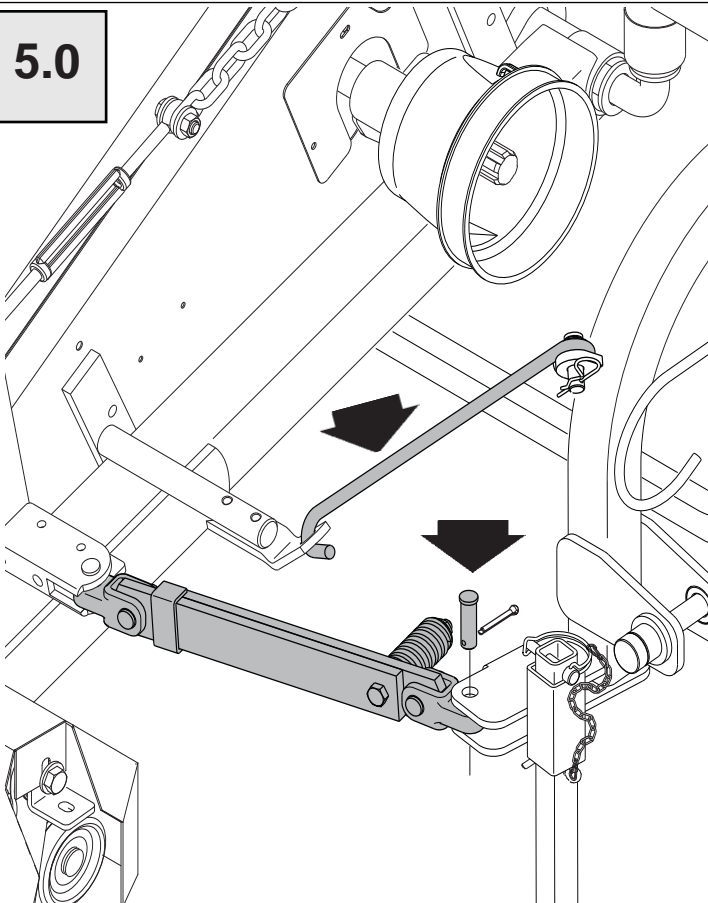

6.0

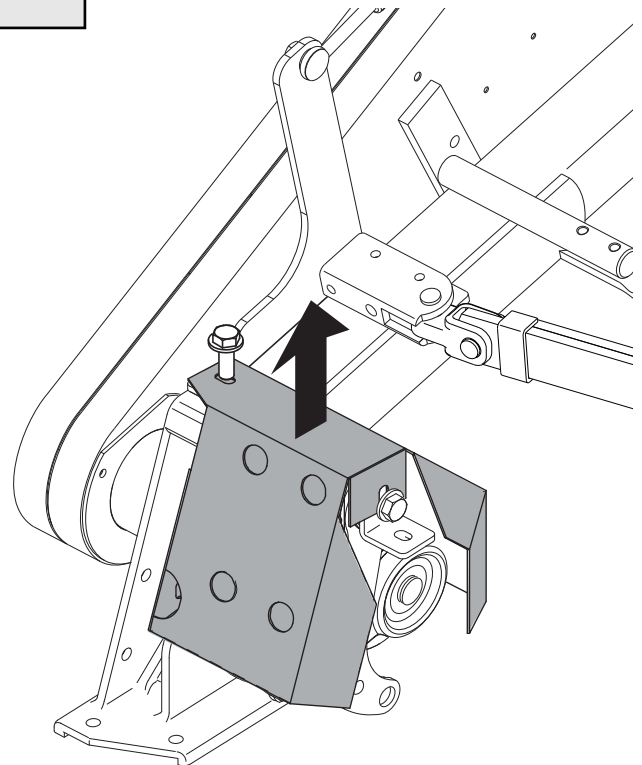

ASSEMBLY

7.0

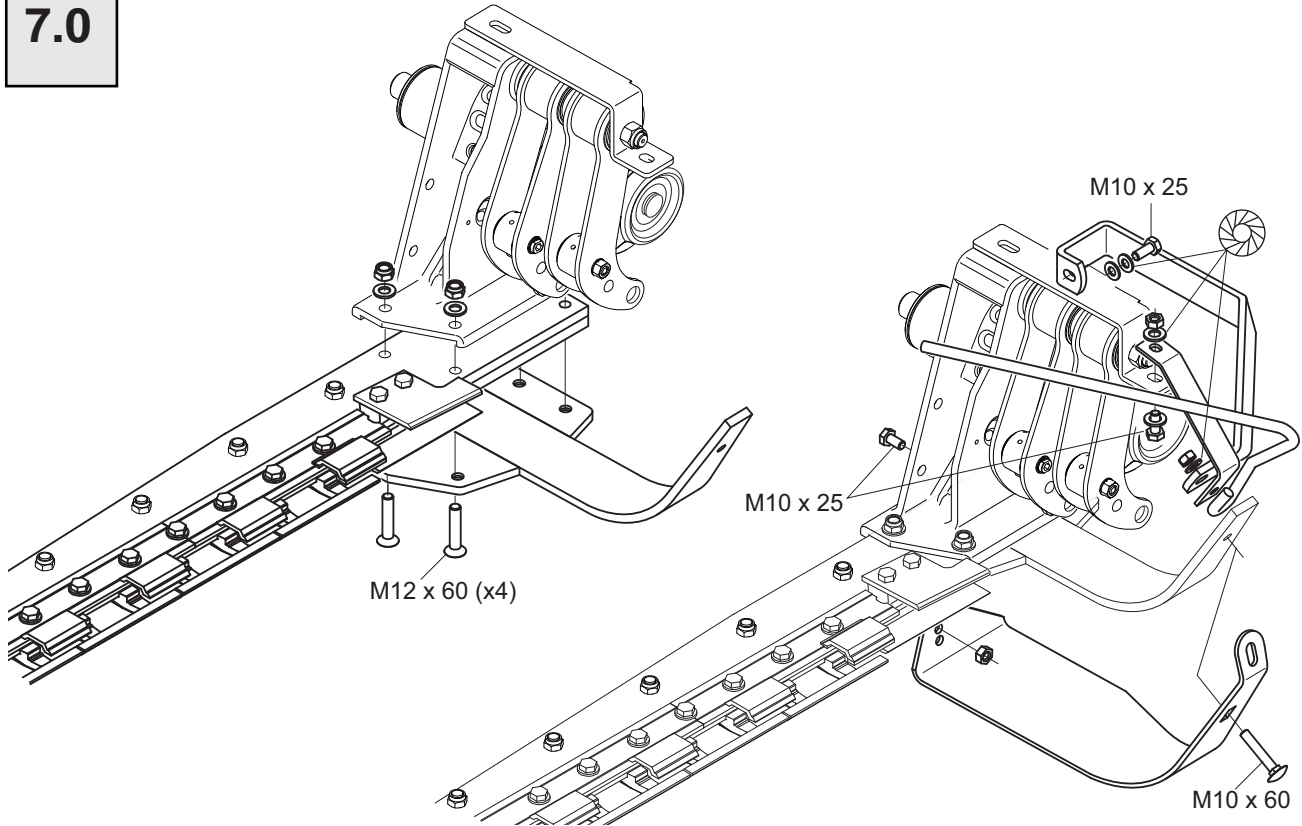

9.0

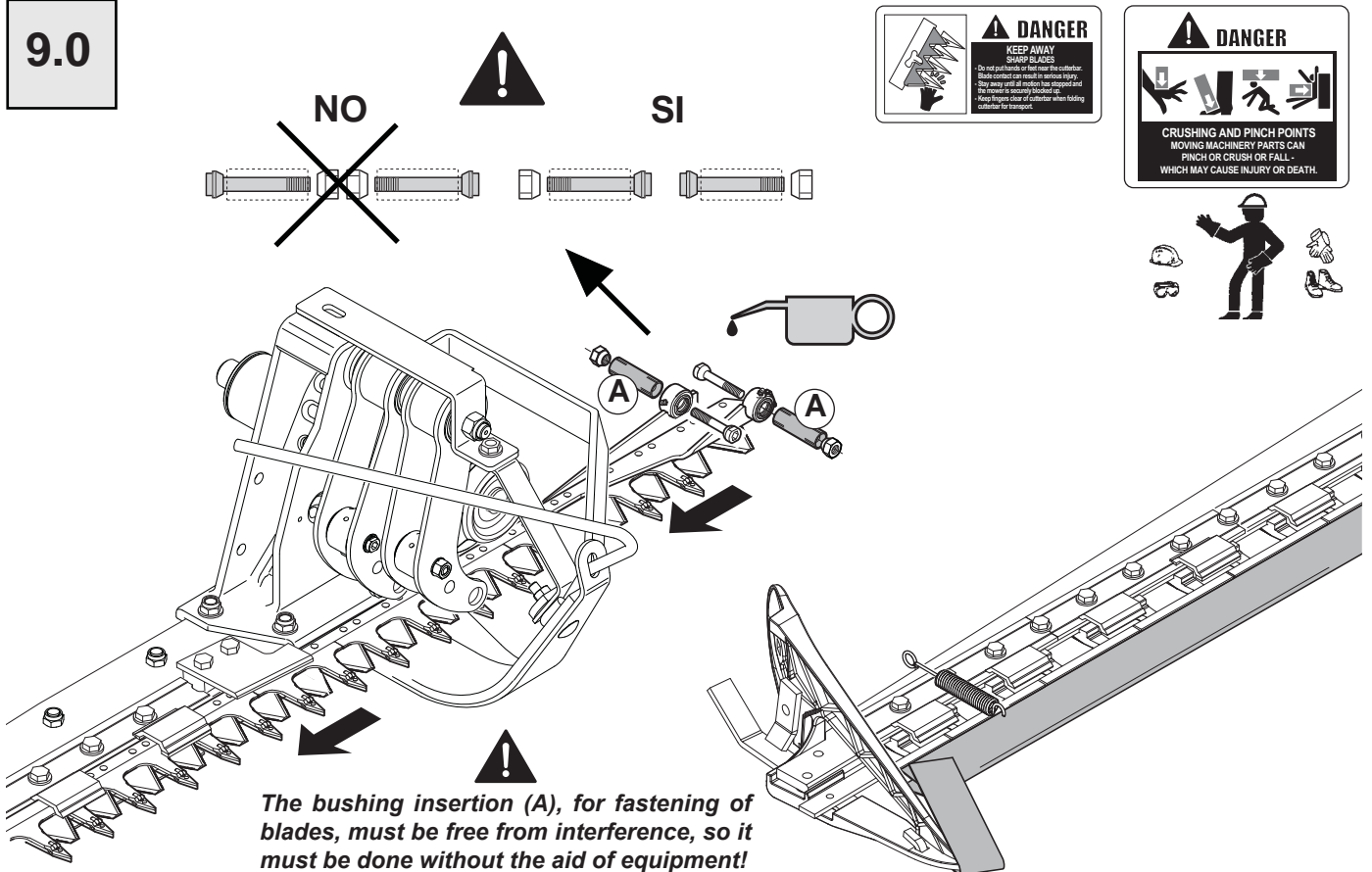

ASSEMBLY

9.0

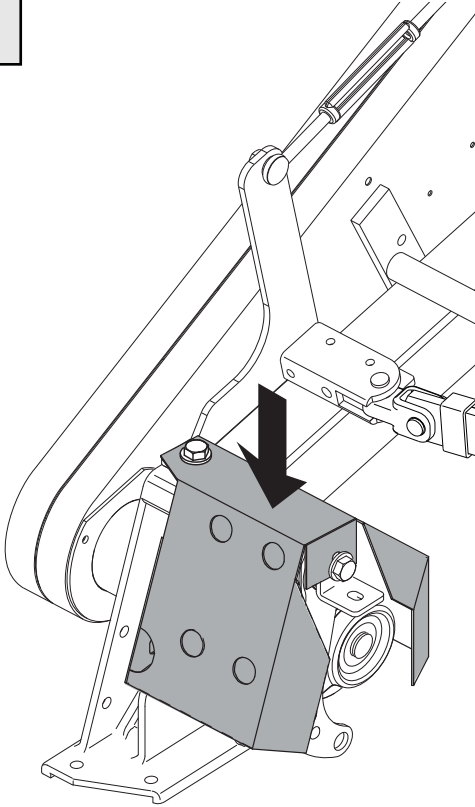

10.0

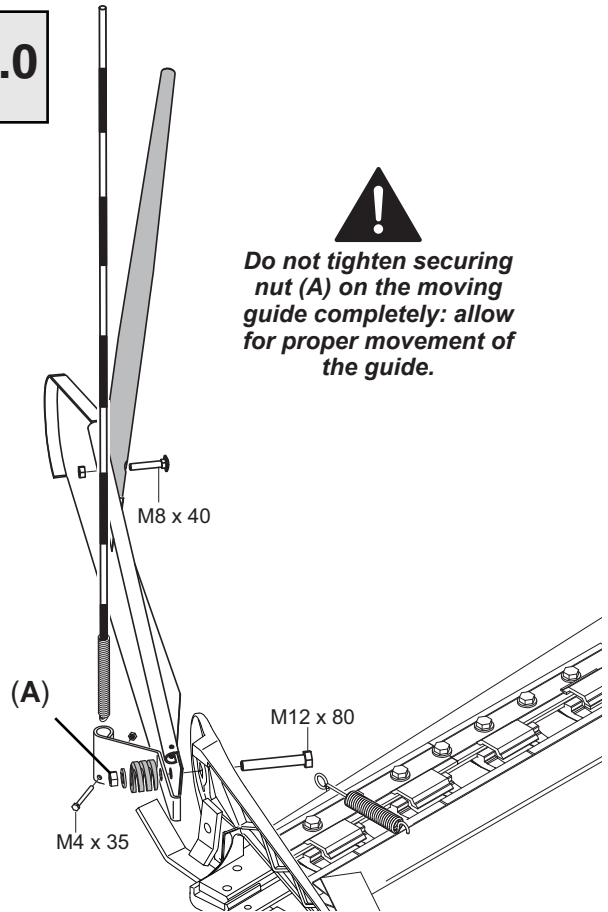

11.0

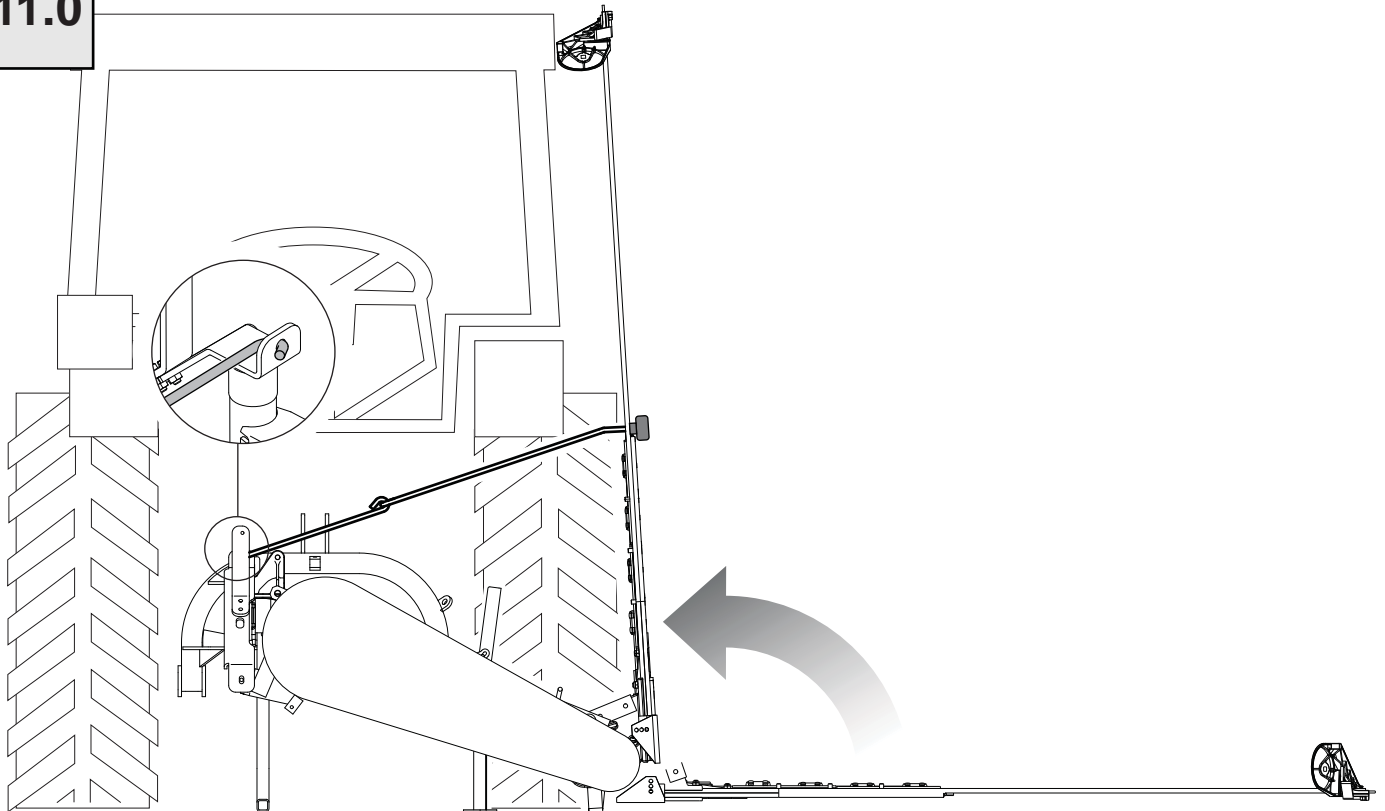

11.0

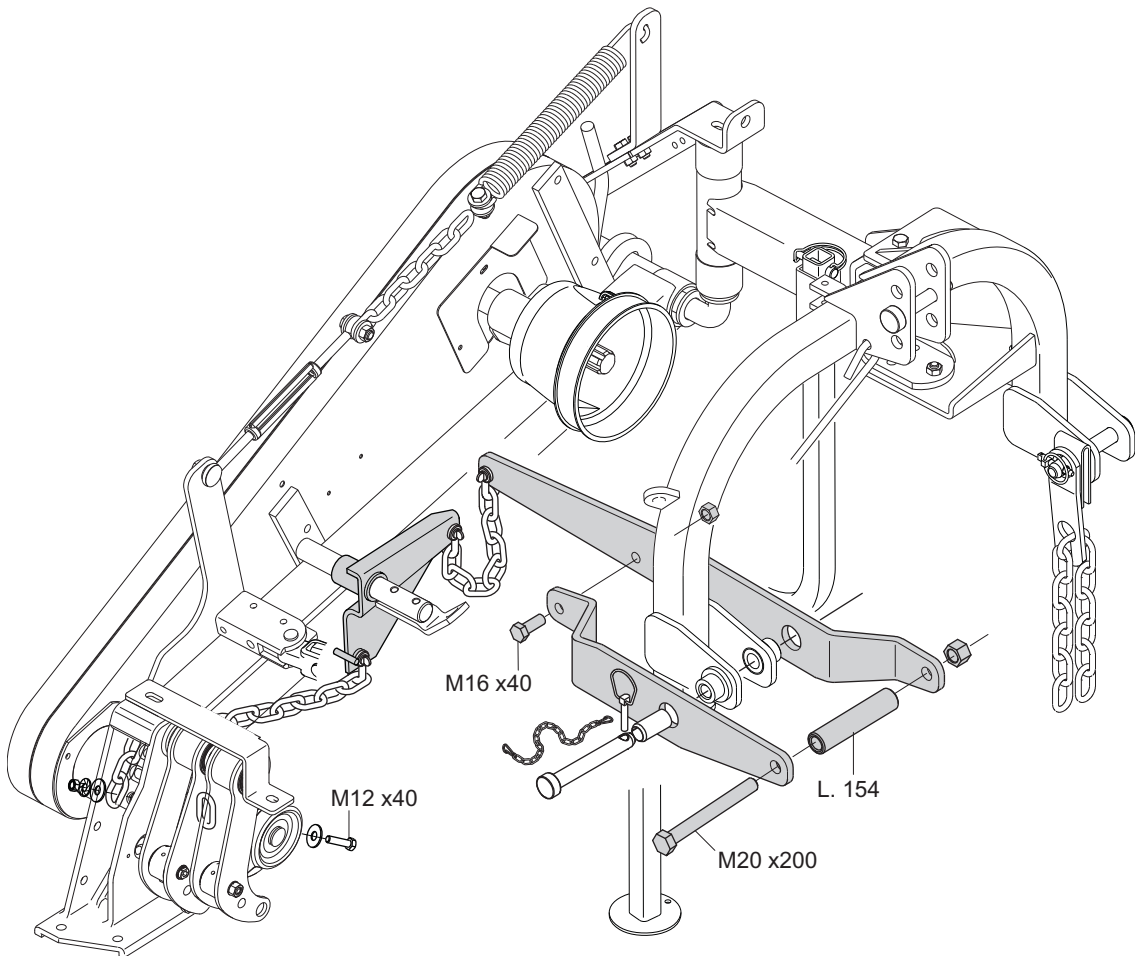

SPARE PARTS

Spare parts

Orders must be transmitted through our area dealers and should always include the following indications:

- **Type, model and serial number of the machine.** These data are punched on the data plate with which every implement is equipped.
- **Code number of the required spare part.** This will be found in the spare parts catalogue.
- **Description of the part and required quantity.**
- **Means of dispatch.** If this item is not indicated, the Manufacturer, while dedicating particular care to this service, shall not be held responsible for delays in delivery caused by cases of force majeure.
Transport expenses shall always be at the consignee's charge. The goods travel at the purchaser's risk and peril even when sold ex destination.

NOTE: The terms Right or Left indicated in the descriptions refer to the implement when viewed from the rear side.

Table index

Frame	Tav. 10pag. 52
Mechanical lifting system	Tav. 20pag. 54
Transmission	Tav. 30pag. 56
Hinge	Tav. 40pag. 58
Cutting blade (tooth riveted)	Tav. 50pag. 60
Cutting blade(removable tooth)	Tav. 60pag. 62
Wear-proof skids	Tav. 70pag. 64
Hydraulic lifting system	Tav. 80pag. 66

SPARE PARTS

TAV. 10

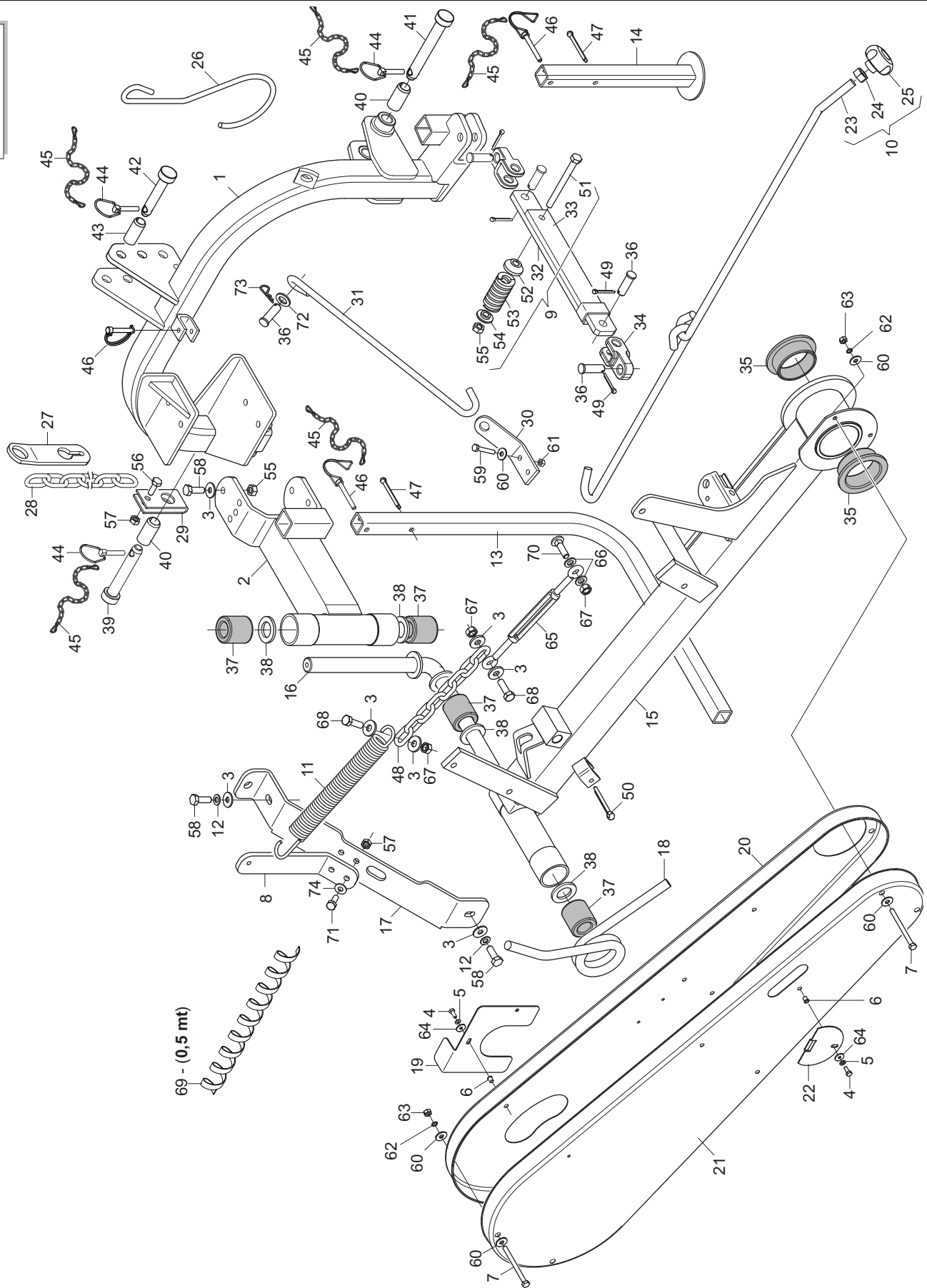

SPARE PARTS

TAV. 10

FRAME

Pos.	Cod.	Description	Pos.	Cod.	Description
1	G12217592	ASS.3RD POINT FRAME '09	39	F20100047	BOLT D22 L108 C43 ZN
2	G12217821	JOINT FBR	40	G21010042	BUSHING 1.-2. POINT
3	G20970035	WASHER 32X4X13	41	F20100115	GASPARDO PIN 22X144 ZN
4	F01020403	BOLT M6X1X16 U5739 8.8 ZN	42	F20100035	BOLT D19 L86 C43 ZN
5	F01410037	WASHER M6 6,4X12,5X1,6 U6592ZN	43	G12217660	THIRD POINT BUSH
6	F02250680	THREADED INSERT M6X13 ZN	44	F02200507	SNAP PIN D9 B/83 ZN
7	F01020092	BOLT 8 X110 5737 8.G GALVANIZ.	45	G13812311	CHAIN WITH SPRING CATCH
8	G12219140	SPRING LINK PLATE	46	F02200562	SNAP PIN D.8X 70 ZN
9	G12218170	ASS.ING SNAP TIGHTE.FBR PLUS	47	F02200272	SPLIT PIN 10 X60 1336 GALVAN.
10	G12219200	TIE CUTTING BAR FBR PLUS09	48	G12219180	CHAIN D.8 L.255 ZN
11	G16214150	ROW-MARKER SPRING ZN	49	F02200195	SPLIT PIN 4 X30 U1336 ZN
12	F01430071	WASHER D12 DIN 6798 D.INT.ZN	50	F02200260	SPLIT PIN 8 X60 1336 ZN
13	G12217810	PROP TUBE	51	F01020176	BOLT M12X1,75X130 5737 8.8 ZN
14	G12217650	FRONT PROP	52	G21120301	CONE DISCONNECT FB940
15	G12217801	ASS.HINGE HOLDER ARM '09	53	F02400013	GAS SPRING 38X75 SPEC.
16	G21030010	ARM ARTICULATION	54	G22310047	REAR ARM BUSHING DP
17	G12218190	JUNCTION ELEMENT FBR PLUS	55	F01230059	LOCK-NUT M12X1,75 D982 ZN
18	G21120319	HINGE ARM SPRING FB940	56	F01020476	BOLT M10X1,5X30 U5739 8.8 ZN
19	G12236471	PDP GUARD	57	F01220033	NUT M10X 1,5 D980 8 ZN
20	G21120215	INNERPROTECTION CASE FB/S	58	F01020528	BOLT M12X1,75X40 U5739 10.9ZN
21	G21120216	OUTERPROTECTION CASE FB/S	59	F01020072	BOLT M8X1,25X50 U5737 8.8 ZN
22	G21120217	WINDOW COVER CONTR. FB/S	60	G20970140	WASHER 20X2X8,5
23	G12219160	BLADE TENSIONER ASSEMBLY	61	F01230034	LOCK NUT M8X1,25 D982 8 ZN
24	F01200306	NUT M14X2	62	F01430059	WASHER M8 8,4X15X0,8 U8842J ZN
25	F06220023	4-LOBE HANDWHEEL M14	63	F01200244	NUT M8 X1,25 U5588 6.8 ZN
26	F20120400	SHAFT HOOK SUPPORT	64	F01420037	WASHER M6 6,4X24X2 U6593 ZN
27	G21030007	TRACTOR COUPLING PLATE	65	F02250708	TIE-ROD 2-EYES M12 GALVANIZED
28	G21030035	CHAIN L.900	66	F01410076	WASHER 12 13X 24X2,5 U6592 ZN
29	G21030034	FRAME COUPLING	67	F01220048	NUT M12X1,75 D980 8 ZN
30	G21120308	SAFETY HOOK COUPLING FB	68	F01020152	SCREW M12X1,75X 40 5737 8.8 ZN
31	G12217440	FRAME LINK HOOK ZN	69	F05150484	ESPIRAL PROTECIEN D.27-32
32	G12218160	SLIDING ROD	70	F01060120	BOLT M12X1,75X40 U5732 8,8 ZN
33	G12217761	SNAP TIE ROD GUIDE	71	F01020479	BOLT M10X1,5X35 U5739 8.8 ZN
34	G12217950	FORK FOR TRIP TIE-ROD	72	F01410100	WASHER M16 17X30X3 U6592 ZN
35	G66248064	HINGE ARM BUSHING FB.	73	F02200363	SPRING SPLIT PIN 3X 62 ZN
36	F20100504	U BOLT PIN D.16X45	74	F01420060	WASHER 10,5X30
37	G21030027	RUBBER BLOCKS			
38	G20970067	WASHER 54X5X32			

SPARE PARTS

TAV. 20

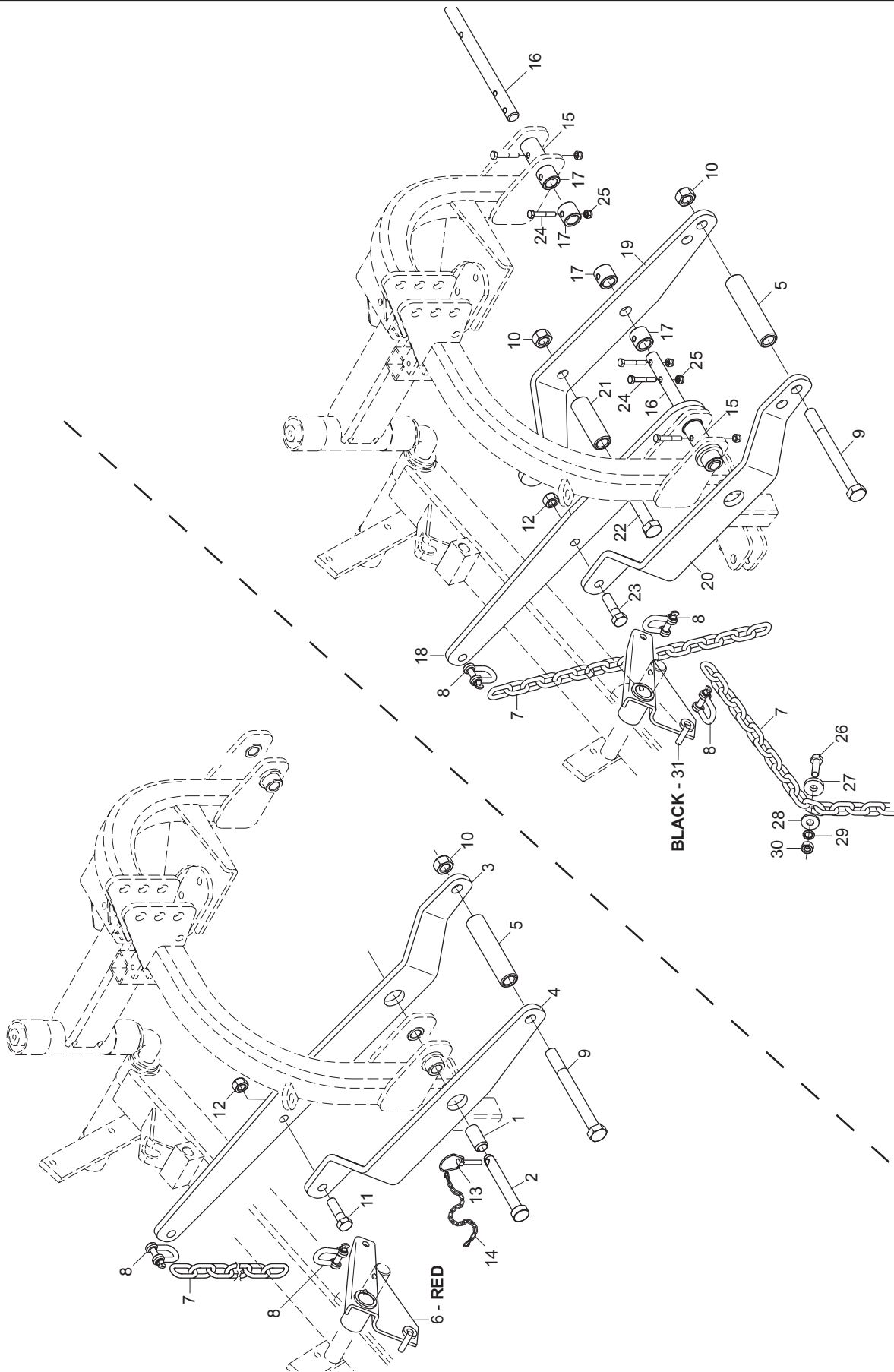

SPARE PARTS

TAV. 20

MECHANICAL LIFTING SYSTEM

Pos.	Cod.	Description	Pos.	Cod.	Description
1	G21010042	BUSHING 1.-2. POINT			
2	F20100115	GASPARDO PIN 22X144 ZN			
3	G12217600	LONG ARM			
4	G12217610	SHORT ARM			
5	G12217620	ARM SPACER			
6	G21120006	LIFTER ROCKER			
7	G21120007	ARM SIDE CHAIN L.600			
8	F02250667	CLEVIS- 3/8- GALVANISED- ART.			
9	F01020323	BOLT M20X200 U5737 8.8 ZN			
10	F01220092	NUT M20X 2,5 D980 8 ZN			
11	F01020566	BOLT M16X2X40 U5739 8.8 ZN			
12	F01220266	NUT M16X 2 D980 8 ZN			
13	F02200507	SNAP PIN D9 B/83 ZN			
14	G13812311	CHAIN WITH SPRING CATCH			
15	G12219260	CENTRAL BUSHING			
16	G12219280	PIN 1-2			
17	G12219270	BUSHING PIN 1-2			
18	G12219290	CENTRAL ARM			
19	G12219300	ARM- INNER			
20	G12219330	SHORT ARM			
21	G12219320	BUSHING 21,1 X33,7 X104			
22	F01020317	BOLT M20X2,5X150 U5737 8.8 ZN			
23	F01020254	BOLT M16X2X55 U5737 10.9 ZD			
24	F01020072	BOLT M8X1,25X50 U5737 8.8 ZN			
25	F01230034	LOCK NUT M8X1,25 D982 8 ZN			
26	F01020516	SCREW M12X1,75X45 U5739 8.8 ZN			
27	G20970007	WASHER 35X8X13			
28	G20970035	WASHER 32X4X13			
29	F01430071	WASHER D12 DIN 6798 D.INT.ZN			
30	F01200293	NUT M12X1,75 U5588 6.8 ZN			
31	G21120006B	LIFTER ROCKER			

SPARE PARTS

TAV. 30

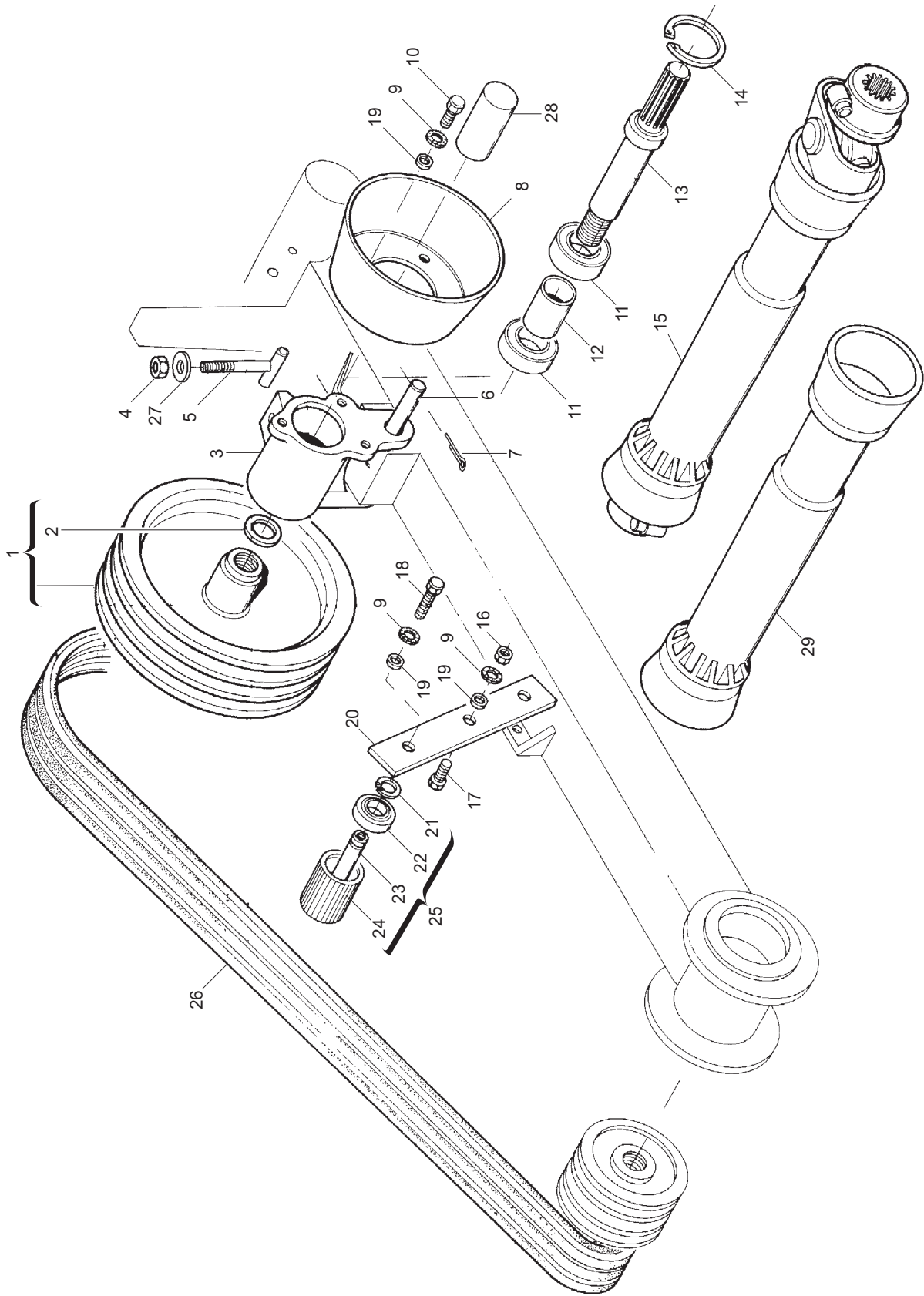

SPARE PARTS

TAV. 30

TRANSMISSION

Description

Pos.

Cod.

Pos.	Cod.	Description
1	G21120117	3 GROOVE DRIVING PULLEY
2	G20970129	WASHER 48X3X30-5
3	G21030015	PTO SUPPORT
4	F01200306	NUT M14X2
5	G21120318	BELT REGISTER ASSY. FB940
6	G21120013	INTERM. TRANSM. SUPP. PIN
7	F02200227	PIN 5X 30 U1336 ZN
8	F05150403	POWER TAKE-OFF PROTECTION HOUS
9	F01430059	WASHER M8 8,4X15X0,8 U8842J ZN
10	F01020432	BOLT M8 X1,25X16 U5739 8.8 ZN
11	F04010174	BEARING D30 D62 B16 6206 2RS
12	G21030020	SPACER
13	G21120152	POWER TAKE-OFF FB
14	F02050392	SEEGER RING E. 62X 2 U7437 C70
15	F08011931	UNIVERSAL JOINT B3 1200 AM
16	F01200244	NUT M8 X1,25 U5588 6.8 ZN
17	F01060045	BOLT 8X40 5732 4.6 GALVANIZED
18	F01020440	SCREW M8X1,25X25 U5739 8.8 ZN
19	G20970140	WASHER 20X2X8,5
20	G21120226	BELT TIGHTENER ROLLERS SUPPORT
21	F02050056	SEEGER RING E. 17X 1 U7435 C70
22	F04010161	BEARING D17 D40 B12 6203 2RS
23	G21120119	3 GROOVE P.TIGHTEN. PIN
24	G66248107	BELT TIGHTENER L.70 FB
25	G21120121	TIGHTENER ROLLER 3G. CP
26	F06010240	BELT- B 93
27	F01410088	WAS.M14 15X 28X2.5 U6592 ZB
28	G19002131	PDP GUARD
29	F08011933	UNIV. JOINT PROTECTION B3X1200

SPARE PARTS

TAV. 40

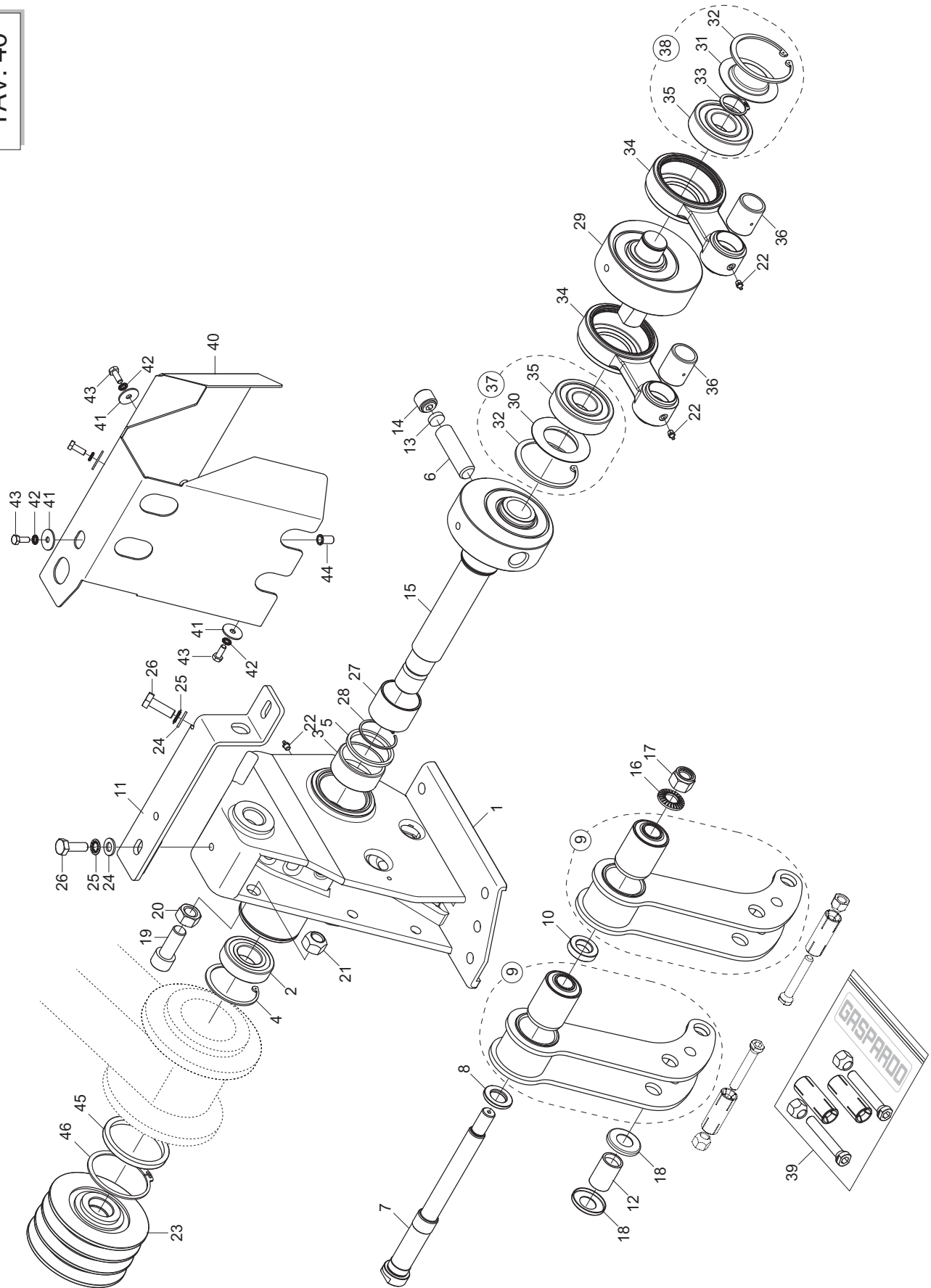

SPARE PARTS

TAV. 40

HINGE

Pos.	Cod.	Description	Pos.	Cod.	Description
1	G12236500	HINGE	39	G21120156	KIT- BLADE FASTENING PIN FB
2	F04010171	BEARING D30 D62 B16 6206 Z	40	G12236710	CONNECTING ROD PROTECTION
3	F04010363	BEARING DHK 5025	41	F01420037	WASHER M6 6,4X24X2 U6593 ZN
4	F02050392	SEEGER RING E. 62X 2 U7437 C70	42	F01430047	WASHER D6 DIN 6798 D.INT.GALV.
5	F03011069	SEALING RING DH 50X58X4	43	F01020403	BOLT M6X1X16 U5739 8.8 ZN
6	G21120126	CONIC PIN FB	44	F02250680	THREADED INSERT M6X13 ZN
7	G12236540	ANTIVIB.SHAFT SUPP.FORK	45	G20970023	WASHER 102X2X75-2
8	G12236610	FORK SPACER (HINGE SIDE)	46	F02050642	STOP RING 75 UNI 7435-75
9	G12236600	ANTIVIBRATION FORK COMP.			
10	G21120118	CENTRAL FORKS SPACER			
11	G12236690	CONNECTING ROD SUPPORT			
12	G21120137	INTERNAL RING FB			
13	G21120136	PIN SPACER FB			
14	G21120127	PIN GRUB-SCREW FB			
15	G21120223	HINGE SPINDLE FB/S			
16	F01460139	CONTACT ELAST. WASHER D16			
17	F01230085	NUT M16X 2 D982 8 ZN			
18	G20970519	BOTTOMED WASHER 39X20-25X5X1			
19	G21120221	BOLT 14X30 5931 8.8			
20	G12236500	NUT M16X2 U5588 8.8 ZN			
21	F01220266	NUT M16X 2 D980 8 ZN			
22	F01100011	GREASE NIPPLE M6X1 7663-A ZN			
23	G21120118	DRIVEN PULLEY 3 SHEAVES			
24	F01410064	ARAND. M10 10,5X20X2 U6592 ZN			
25	F01430023	WASHER D10 DIN 6798 D.INT.ZN			
26	F01020476	BOLT M10X1,5X30 U5739 8.8 ZN			
27	F04100131	INTERNAL IR. RING 45X50X35			
28	F04010409	SHOULDER RING WR 45			
29	G21170020	HINGE ECCENTRIC			
30	G66248111	DUSTCOVER HINGE FB			
31	G21120028	PROTECTION PLUG			
32	F02050403	SEEGER RING E.72X2,5 U7437 C70			
33	F02050112	SEEGER RING 30X 1,5 U7435 C70			
34	G21120128	PIN HINGE CONNECTING ROD FB			
35	F04010215	BEARING D30 D72 B19 6306 2RSC3			
36	F04010362	BEARING DHK 2538			
37	G21120153	KIT- INT. CONN. ROD BEARING FB			
38	G21120154	KIT- EXT. CONN. ROD BEARING FB			

SPARE PARTS

TAV. 50

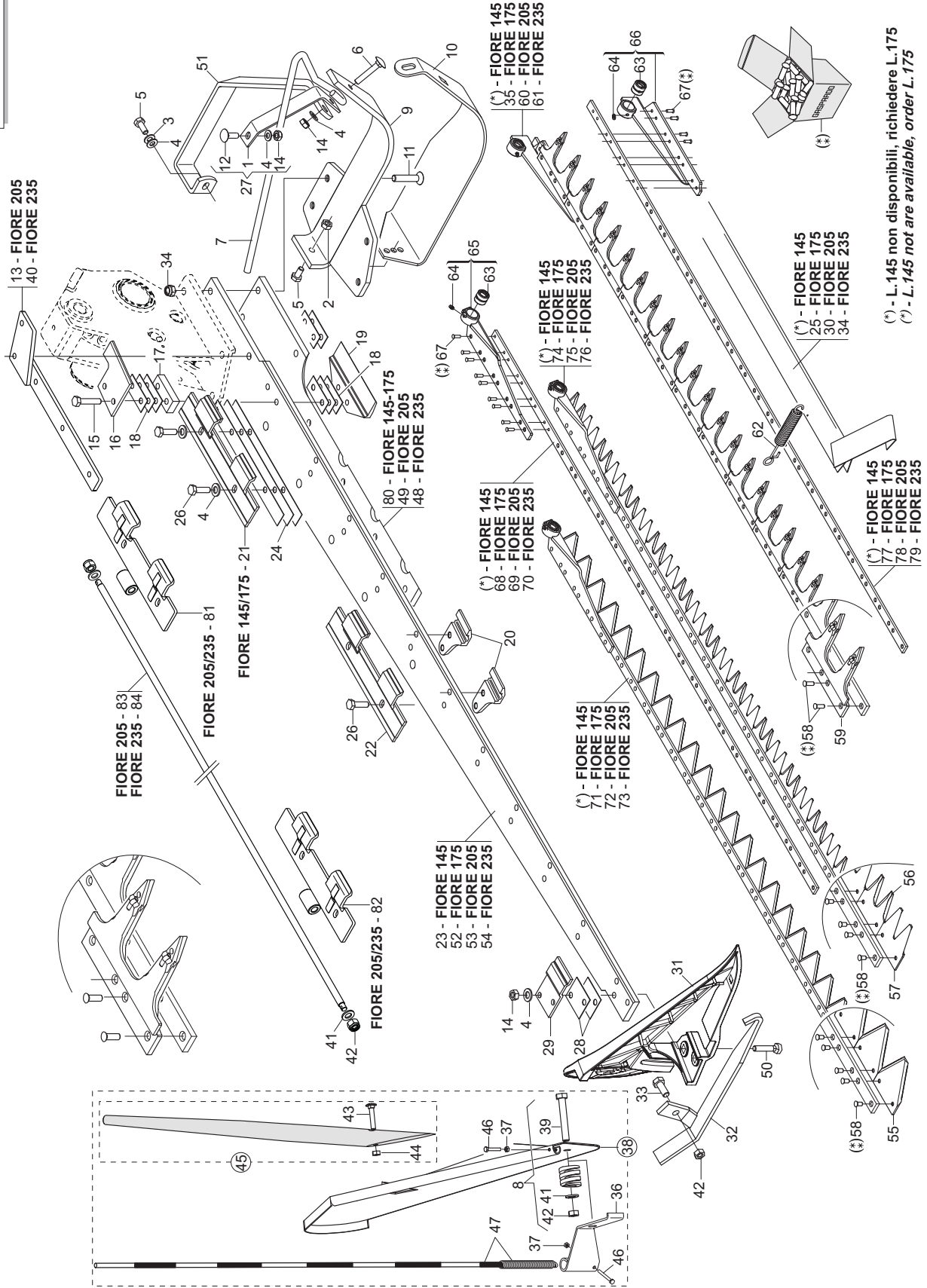

(*) - L. 145 non disponibili, richiedere L.175
(*) - L. 145 not available, order L. 175

SPARE PARTS

TAV. 50

CUTTING BLADE (TOOTH RIVETED)

Pos.	Cod.	Description	Pos.	Cod.	Description
1	G21120321	INNER SLIDE SPACER FB940	43	F01060045	BOLT 8X40 5732 4.6 GALVANIZED
2	F01200270	NUT M10X 1,5 U5588 6.8 ZN	44	F01230034	LOCK NUT M8X1,25 D982 8 ZN
3	F01430023	WASHER D10 DIN 6798 D.INT.ZN	45	G20800061	SWATHBOARD ROD ASSY.
4	F01410064	ARAND. M10 10,5X20X2 U6592 ZN	46	F01020012	BOLT 4X40 5737 8.G GALVANIZ.
5	F01020472	BOLT M10X1,5X25 U5739 8.8 ZN	47	G13011660	INDICATIN BAR
6	F01060081	BOLT 10X60 5732 4.6- GALVANIZ	48	G13017611	5 HOLES BAR REINFORCEMENT
7	G21120322	HINGE PROTECTION FB940	49	G13017601	4 HOLES BAR REINFORCEMENT
8	G21120133	SWATHBOARD BOLT ASSY. FB	50	F01030501	BOLT TSQST 10X45 8.8
9	G19205340	INTERNAL RUNNER'09 ASS.BLY	51	G13014250	GUARD ROD
10	G21120324	RUNNER WIDE INT. SLIDE FB940	52	G13012221	BAR DNE 1,75 FBR PLUS
11	F01030121	BOLT 12X60 5933 8.8 GALVANIZ.	53	G13012261	BAR DNE 2,05 FBR PLUS
12	F01060069	BOLT 10X30 5732 4.6	54	G13012301	BAR MT. 2,35
13	G13018140	UPPER REINFORCED BAR 2,05 DNE	55	G21120243	CUT SECTION FB/S
14	F01220033	NUT M10X 1,5 D980 8 ZN	56	G13013550	LOWER DOUBLE POINT SECTION
15	F01020114	BOLT M10X 1,5X50 U5737 8.8 ZN	57	G13013540	UPPER DOUBLE POINT SECTION
16	G21120312	SUP:INTERNAL BLADE GUIDE	58	F02250519	RIVETS TSC 6X13,8 QTY 200
17	G21120231	SHIMS MM.10 FB/S	59	G13014240	RIVETED TOOTH EVO11
18	G21120044	SHIMS- LOWER INT. GUIDE	60	G13013871	COMPL.RIB.TOOTH BLADE FBR 2,05
19	G21120045	INTERNAL LOWER BLADE GUIDE	61	G13013881	COMPL.RIB.TOOTH BLADE FBR 2,35
20	G21120042	LOWER BLADE GUIDE	62	G65337002	TRACTION SPRING GUARD FS
21	G21120232	UPPER INTERNAL BLADE GUIDE	63	G21120048	BUSHING- BLADE HEAD 28X20X24
22	G21120041	UPPER BLADE GUIDE	64	F01100011	GREASE NIPPLE M6X1 7663-A ZN
23	G21120314	BAR MT. 1.45 FB940	65	G21120267	INTERNAL SECTION BLADEHEAD
24	G21120320	SHIMS- UPPER BLADE GUIDE	66	G21120259	EXT.COMPLETE TOOTH BLADEHEAD
25	G21120054	GUARD - PROTECTION MT.1-75	67	F02250520	RIVETS TSC 6X19,8 QTY 154
26	F01020479	BOLT M10X1,5X35 U5739 8.8 ZN	68	G21120246	ROD SECTIONS MT. 1.75 FB/S
27	G13013120	COMPLETE SPACER	69	G21120247	ROD SECTIONS MT. 2.05 FB/S
28	G21120040	SHIMS MM.1 UPPER EXT. GUIDE	70	G21120248	ROD SECTIONS MT. 2.35 FB/S
29	G21120039	UPPER OUT. BLADE GUIDE	71	G21120240	CUTTING BLADE MT.1-75 FB/S
30	G21120112	COMPL. PROTECTION MT.2-05	72	G21120241	COMPL.SECTION-HOLDING BAR 2,05
31	G19200903	OUTER BAR SUPPORT FBR	73	G21120242	COMPL.SECTION-HOLDING BAR 2,35
32	G21120038	EXT. RUNNER SLIDE	74	G13013620	DOUBLE-TIP SECTION BLADE 1.75
33	F01020512	BOLT M12X1,75X35 5739 8.8 ZN	75	G13013630	DOUBLE EDGED BLADE GUIDE SECT
34	G21120266	COMPL. PROTECTION .MT.2-35 FB/	76	G13013640	DOUBLE POINT SEC.BLADE 2,35
35	G13013861	COMPL.RIB.TOOTH BLADE FBR 1,75	77	G21120251	BLADE ROD- MT. 1.75 FB/S
36	G13011650	INDICATION BAR SUPPORT	78	G21120252	BLADE ROD- MT. 2.05 FB/S
37	F01230016	NORM.SELF-LOCKING NUT 4 GALVAN	79	G21120253	BLADE ROD- MT. 2.35 FB/S
38	G21120134	SWATHBOARD - ASSY. FB	80	G13017621	2 HOLES BAR REINFORCEMENT
39	F01060105	BOLT 12X80 5732 4.6	81	G13018040	UPPER INNER BLADE GUIDE DN
40	G13018110	UPPER REINFORCED BAR 2,35 DNE	82	G13018050	UPPER BLADE GUIDE DN
41	F01410076	WASHER 12 13X 24X2,5 U6592 ZN	83	G13018060	TIE-ROD M12 L.1650 -30 -30
42	F01230059	LOCK-NUT M12X1,75 D982 ZN	84	G13018070	TIE-ROD M12 L.1955 -30 -30

SPARE PARTS

TAV. 60

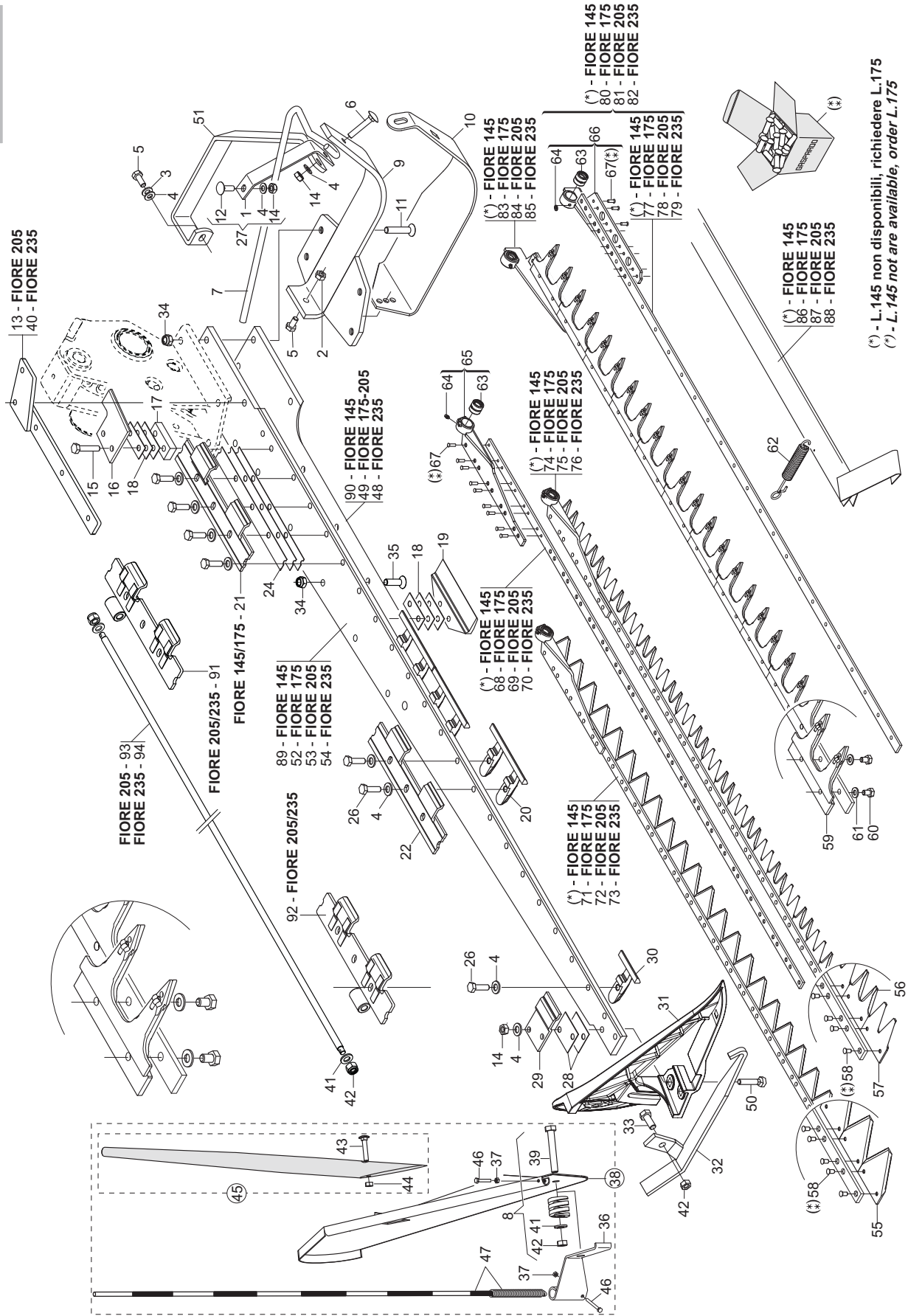

(*) - L.145 non disponibili, richiedere L.175
 (*) - L.145 not available, order L.175

CUTTING BLADE (REMOVABLE TOOTH)

Pos.	Cod.	Description	Pos.	Cod.	Description
1	G21120321	INNER SLIDE SPACER FB940	50	F01030501	BOLT TSQST 10X45 8.8
2	F01200270	NUT M10X 1,5 U5588 6.8 ZN	51	G13014250	GUARD ROD
3	F01430023	WASHER D10 DIN 6798 D.INT.ZN	52	G13013420	BAR DSE 1,75 FBR PLUS
4	F01410064	ARAND. M10 10.5X20X2 U6592 ZN	53	G13013460	BAR DSE 2,05 FBR PLUS
5	F01020472	BOLT M10X1,5X25 U5739 8.8 ZN	54	G13013030	BAR DSE FBR PLUS M.2,35
6	F01060081	BOLT 10X60 5732 4.6- GALVANIZ	55	G21120243	CUT SECTION FB/S
7	G21120322	HINGE PROTECTION FB940	56	G13013550	LOWER DOUBLE POINT SECTION
8	G21120133	SWATHBOARD BOLT ASSY. FB	57	G13013540	UPPER DOUBLE POINT SECTION
9	G19205340	INTERNAL RUNNER'09 ASS.BLY	58	F02250519	RIVETS TSC 6X13,8 QTY 200
10	G21120324	RUNNER WIDE INT. SLIDE FB940	59	G13014220	REMOVABLE TOOTH EVO11
11	F01030121	BOLT 12X60 5933 8.8 GALVANIZ.	60	F01010222	BOLT 8X1X12 5740 10.9
12	F01060069	BOLT 10X30 5732 4.6	61	F01460138	CONTACT ELAST. WASHER D8
13	G13018130	UPPER REINFORCED BAR 2.05 DSE	62	G65337002	TRACTION SPRING GUARD FS
14	F01220033	NUT M10X 1,5 D980 8 ZN	63	G21120048	BUSHING- BLADE HEAD 28X20X24
15	F01020114	BOLT M10X 1,5X50 U5737 8.8 ZN	64	F01100011	GREASE NIPPLE M6X1 7663-A ZN
16	G21120312	SUP. INTERNAL BLADE GUIDE	65	G13013190	COMPL. BLADEHEAD SECTIONS
17	G13011600	INT. BLADE GUIDE SUPPORT	66	G13013230	DEMONT. TOOTH BLADEHEAD
18	G21120044	SHIMS- LOWER INT. GUIDE	67	F02250520	RIVETS TSC 6X19,8 QTY 154
19	G21120045	INTERNAL LOWER BLADE GUIDE	68	G21120246	ROD SECTIONS MT. 1.75 FB/S
20	G13013151	LOWER DOUBLE BLADE GUIDE	69	G21120247	ROD SECTIONS MT. 2.05 FB/S
21	G19203311	UPPER BLADE INT. GUIDE REMOVAB	70	G21120248	ROD SECTIONS MT. 2.35 FB/S
22	G19203301	UPPER BLADE GUIDE REMOVABLE TI	71	G13013580	COMPL. SECTION-HOLDING BAR 1.75
24	G13011510	SHIM FOR UPPER BLADE GUIDE	72	G13013590	COMPL. SECTION ROD MT 2,05
26	F01020479	BOLT M10X1,5X35 U5739 8.8 ZN	73	G13013090	SECT.HOLDER ROD 2,35 FBR
27	G13013120	COMPLETE SPACER	74	G13013670	DOUBLE POINT SEC.BLADE 1,75 DS
28	G21120040	SHIMS MM.1 UPPER EXT. GUIDE	75	G13013680	DOUBLE POINT SEC.BLADE 2,05 DS
29	G21120039	UPPER OUT. BLADE GUIDE	76	G13013110	SECT.HOLDER ROD 2,35 FBR
30	G13013511	LOWER SINGLE BLADE GUIDE	77	G13013300	REMV. TOOTH-HOLDING BAR 1.75
31	G19200903	OUTER BAR SUPPORT FBR	78	G13013310	REMV. TOOTH-HOLDING BAR 2.05
32	G21120038	EXT. RUNNER SLIDE	79	G13013040	BLADE ROD- MT. 2,35
33	F01020512	BOLT M12X1,75X35 5739 8.8 ZN	80	G13013340	BLADE HEAD-TOOTH-HOLDING BAR 1
34	F01220048	NUT M12X1,75 D980 8 ZN	81	G13013350	BLADEHEAD TOOTHED ROD ASS.2,05
35	F01030111	BOLT 12X40 5933 8.8 GALVANIZ.	82	G13013050	DSS 2,35 FBR HOLDER ROD
36	G13011650	INDICATION BAR SUPPORT	83	G13013772	COMP.DISM.TOOTH BLADES FBR1,75
37	F01230016	NORM.SELF-LOCKING NUT 4 GALVAN	84	G13013782	COMP.DISM.TOOTH BLADES FBR2,05
38	G21120134	SWATHBOARD - ASSY. FB	85	G13013061	COMP.DISM.TEETH BLADES FBR2,35
39	F01060105	BOLT 12X80 5732 4.6	86	G21120054	GUARD - PROTECTION MT.1-75
40	G13018100	UPPER REINFORCED BAR 2.35 DSE	87	G21120112	COMPL. PROTECTION MT.2-05
41	F01410076	WASHER 12 13X 24X2,5 U6592 ZN	88	G21120266	COMPL. PROTECTION .MT.2-35 FB/
42	F01230059	LOCK-NUT M12X1,75 D982 ZN	89	G13013401	REMOV. TOOTH-HOLDING BAR 1,45
43	F01060045	BOLT 8X40 5732 4.6 GALVANIZED	90	G13017621	2 HOLES BAR REINFORCEMENT
44	F01230034	LOCK NUT M8X1,25 D982 8 ZN	91	G13018000	UPPER INNER BLADE GUIDE DS
45	G20800061	SWATHBOARD ROD ASSY.	92	G13018010	UPPER BLADE GUIDE DS
46	F01020012	BOLT 4X40 5737 8.G GALVANIZ.	93	G13018030	TIE-ROD M12 L.1780 -30 -30
47	G13011660	INDICATIN BAR	94	G13018020	TIE-ROD M12 L.2085 -30 -94
48	G13013081	5 HOLES BAR REINFORCEMENT			
49	G13013071	4 HOLES BAR REINFORCEMENT			

SPARE PARTS

TAV. 70

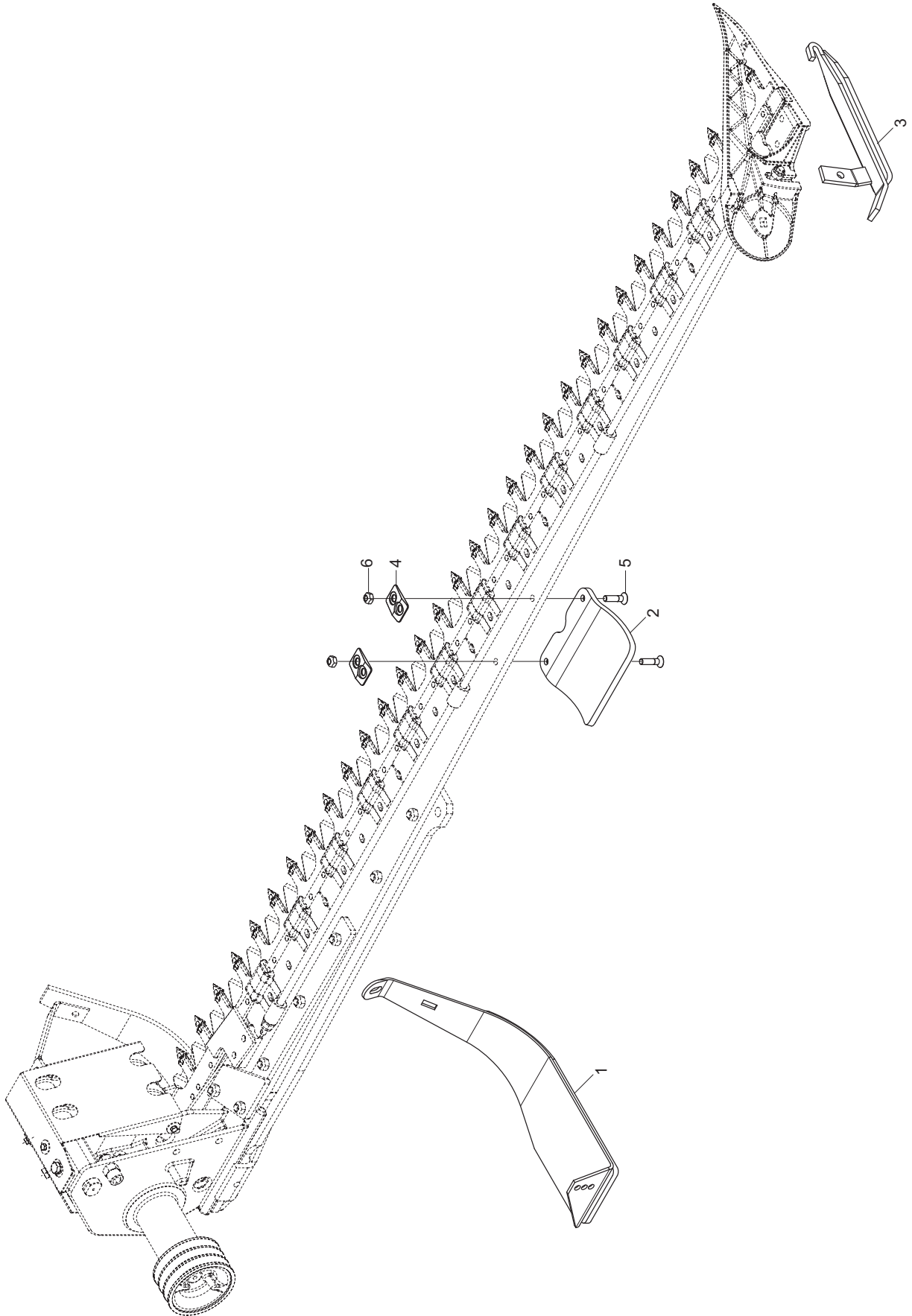

SPARE PARTS

TAV. 70

WEAR-PROOF SKIDS

Pos.	Cod.	Description	Pos.	Cod.	Description
1	G13018160	INTERNAL SLIDE			
2	G13018190	CENTRAL SLIDE			
3	G13018180	EXTERNAL SLIDE			
4	G13017900	ADJ.MENT WEDGE SLIDE BAR ZN			
5	F01030097	BOLT M10X1,5X 40 U5933 10.9 ZD			
6	F01220033	NUT M10X 1,5 D980 8 ZN			

SPARE PARTS

TAV. 80

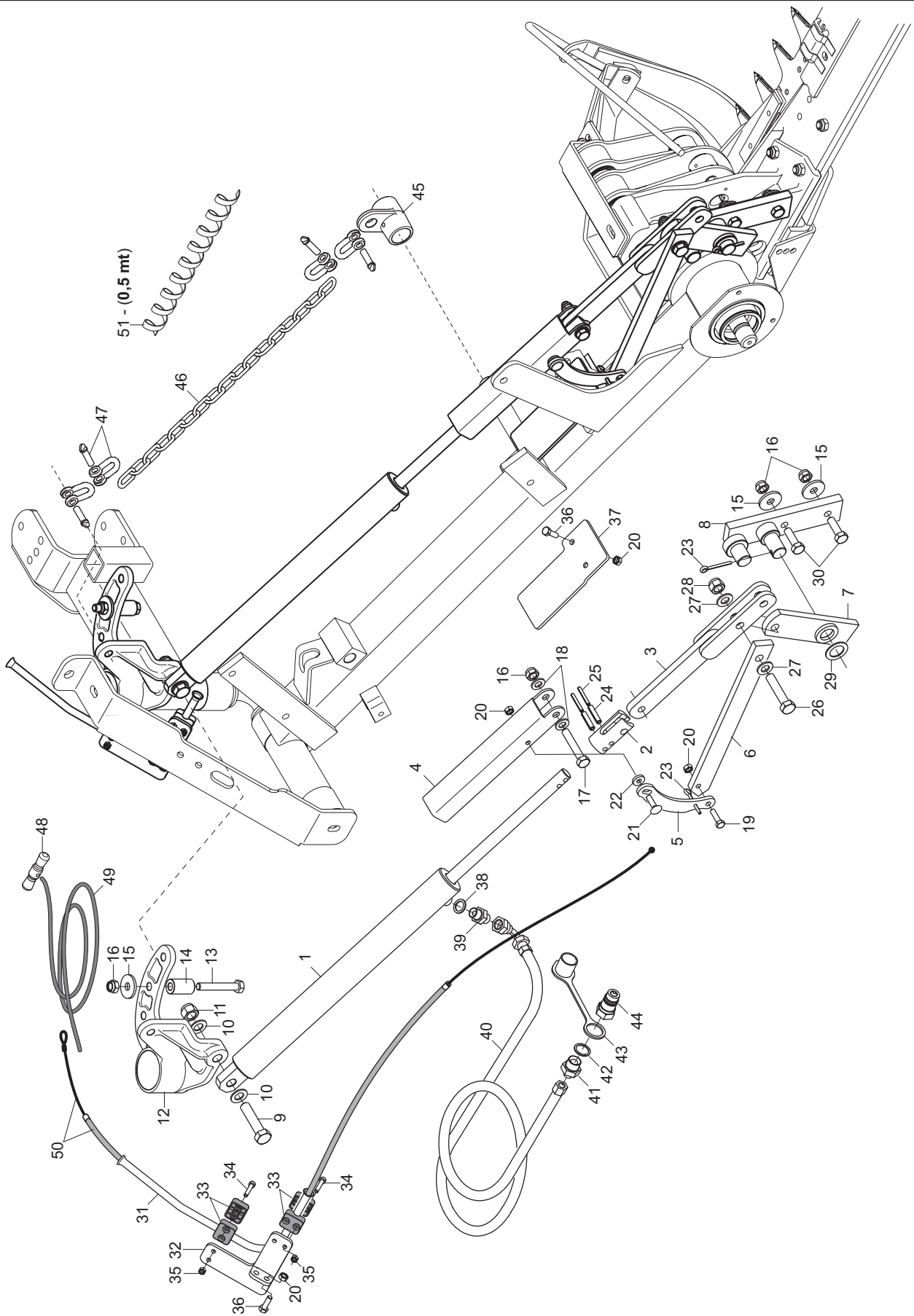

SPARE PARTS

TAV. 80

HYDRAULIC LIFTING SYSTEM

Pos.	Cod.	Description	Pos.	Cod.	Description
1	G14911000	CYLINDER TU 20X40 -380	39	G16011690	UPRIGHT 1/4" NIPPLE WITH GRUB
2	G12216820	CYLINDER COUPLING	40	G23440517	PIPE 1/4R2 C-F 1/4 L2000 HL/ID
3	G12217900	FORK LEVER CONNECTION	41	F03150211	NIPLE MM CIL-CIL 1/4-1/2 ZN
4	G12219070	STOP LIFT BAR FBR PLUS ZN	42	F03151237	COPPER WASHER 21X27X1,5 1/2
5	G12219060	LIFT LIMITER ROD	43	F05150325	COVER CONNECT F 1/2 RED
6	G12219080	LIFTING FULCRUM ROD	44	F03150935	QUICK CONNECT MALE CONE 1/2
7	G19204240	LIFTING LEVER	45	G19204250	BUSHING- TIE ROD
8	G12219020	ASSY LIFTING PLATE FBR PLUS	46	G21120007	ARM SIDE CHAIN L.600
9	F01020260	BOLT M16X2X70 U5737 8.8 ZN	47	F02250667	CLEVIS- 3/8- GALVANISED- ART.
10	G20970111	WASHER 29,8X2X16,5	48	F05150114	HANDLE
11	F01230084	SELF LOCKING NUT M16X1,5	49	F05150410	PLASTIC ROPE D5
12	G19204260	CYLINDER COUPLING	50	F03100344	COVER C/W WIRE D.1,9>
13	F01020166	BOLT M12X1,75X80 U5737 8.8 ZN	51	F05150484	ESPIRAL PROTECCION D.27-32
14	G18802150	BUSHING 12,3X25X42			
15	G20970085	WASHER 40X4X13			
16	F01230059	LOCK-NUT M12X1,75 D982 ZN			
17	F01020164	BOLT M12X1,75X70 U5737 8.8 ZN			
18	F01410076	WASHER 12 13X 24X2,5 U6592 ZN			
19	F01020445	BOLT M 8X30			
20	F01220022	NUT M8X 1,25 D980 8 ZN			
21	F01060041	BOLT 8 X25 5732 4.6 GALVANIZED			
22	G20970104	WASHER 21X4X8-5			
23	F02200229	SPLIT PIN 5X 45 U1336 ZN			
24	F02100141	PIN EL. 8X 36 U6873 C70 BR			
25	F02100314	PIN EL.5 X36 DIN 1481 INOX			
26	F01020207	BOLT M14X2X70 U5737 8.8 ZN			
27	F01410088	WAS.M14 15X 28X2,5 U6592 ZB			
28	F01230072	SELF LOCKING NUT M14X1,5			
29	G20970070	WASHER 40X2X26			
30	F01020154	BOLT M12X1,75X45 U5737 8.8 ZN			
31	G12219120	CABLE PROTECTION			
32	G12219050	CABLE PROTECTION SUPPORT			
33	F03151136	COLLAR A1-12 S			
34	F01040066	BOLT 6 X35 5931 8.G GALVANIZ.			
35	F01220011	NUT M6X1 D980 8 ZN			
36	F01020440	SCREW M8X1,25X25 U5739 8.8 ZN			
37	G12219110	ASSY SLIDING PLATE ZN			
38	F01500012	COPPER WASHER 13X19X1,5-1/4"			

WARRANTY

WARRANTY

MASCHIO GASPARDO warrants this product to be free from defect in material and workmanship. Except as otherwise set forth below, the duration of this Warranty shall be for TWELVE (12) MONTHS COMMENCING ON THE DATE OF DELIVERY OF THE PRODUCT TO THE ORIGINAL PURCHASER.

Under no circumstances will this Warranty apply in the event that the product, in the good faith opinion of MASCHIO GASPARDO, has been

subjected to improper operation, improper maintenance, misuse, or an accident. This Warranty does not apply in the event that the product has been materially modified or repaired by someone other than MASCHIO GASPARDO, a MASCHIO GASPARDO authorized dealer or distributor, and/or a MASCHIO GASPARDO authorized service center. This Warranty does not cover normal wear or tear, or normal maintenance items. This Warranty also does not cover repairs made with parts other than those obtainable through MASCHIO GASPARDO.

This Warranty is extended solely to the original purchaser of the product. Should the original purchaser sell or otherwise transfer this product to a third party, this Warranty does not transfer to the third party purchaser in any way. There are no third party beneficiaries of this Warranty.

MASCHIO GASPARDO makes no warranty, express or implied, with respect to engines, batteries, tires or other parts or accessories not manufactured by FRONTIER. Warranties for these items, if any, are provided separately by their respective manufacturers.

MASCHIO GASPARDO' obligation under this Warranty is limited to, at MASCHIO GASPARDO' option, the repair or replacement, free of charge, of the product if MASCHIO GASPARDO, in its sole discretion, deems it to be defective or in noncompliance with this Warranty. **The product must be returned to MASCHIO GASPARDO S.p.A. with proof of purchase within thirty (30) days after such defect or noncompliance is discovered or should have been discovered, routed through the dealer and distributor from whom the purchase was made, transportation charges prepaid.** MASCHIO GASPARDO shall complete such repair or replacement within a reasonable time after MASCHIO GASPARDO receives the product.

THERE ARE NO OTHER REMEDIES UNDER THIS WARRANTY. THE REMEDY OF REPAIR OR REPLACEMENT IS THE SOLE AND EXCLUSIVE REMEDY UNDER THIS WARRANTY.

THERE ARE NO WARRANTIES WHICH EXTEND BEYOND THE DESCRIPTION ON THE FACE OF THIS WARRANTY. MASCHIO GASPARDO MAKES NO OTHER WARRANTY, EXPRESS OR IMPLIED, AND MASCHIO GASPARDO SPECIFICALLY DISCLAIMS ANY IMPLIED WARRANTY OF MERCHANTABILITY AND/OR ANY IMPLIED WARRANTY OF FITNESS FOR A PARTICULAR PURPOSE.

MASCHIO GASPARDO shall not be liable for any incidental or consequential losses, damages or expenses, arising directly or indirectly from the product, whether such claim is based upon breach of contract, breach of warranty, negligence, strict liability in tort or any other legal theory. Without limiting the generality of the foregoing, MASCHIO GASPARDO specifically disclaims any damages relating to (i) lost profits, business, revenues or goodwill; (ii) loss of crops; (iii) loss because of delay in harvesting; (iv) any expense or loss incurred for labor, supplies, substitute machinery or rental; or (v) any other type of damage to property or economic loss.

This Warranty is subject to any existing conditions of supply which may directly affect MASCHIO GASPARDO' ability to obtain materials or manufacture replacement parts.

No agent, representative, dealer, distributor, serviceperson, salesperson, or employee of any company, including without limitation, MASCHIO GASPARDO, its authorized dealers, distributors, and service centers, is authorized to alter, modify, or enlarge this Warranty.

This Warranty is effective only if the warranty registration is returned within ten (10) days.

For warranty services contact your selling dealer.

WARRANTY

WARRANTY FOR REPLACEMENT PARTS

MASCHIO GASPARDO warrants this product to be free from defect in material and workmanship for a period of ninety (90) days from the date of delivery of the product to the original purchaser.

Under no circumstances will this Warranty apply in the event that the product, in the good faith opinion of MASCHIO GASPARDO, has been subjected to improper operation, improper maintenance, misuse, or an accident. This Warranty does not cover normal wear or tear, or normal maintenance items.

This Warranty is extended solely to the original purchaser of the product. Should the original purchaser sell or otherwise transfer this product to a third party, this Warranty does not transfer to the third party purchaser in any way. There are no third party beneficiaries of this Warranty.

MASCHIO GASPARDO' obligation under this Warranty is limited to, at MASCHIO GASPARDO' option, the repair or replacement, free of charge, of the product if MASCHIO GASPARDO, in its sole discretion, deems it to be defective or in noncompliance with this Warranty. **The product must be returned to MASCHIO GASPARDO with proof of purchase within thirty (30) days after such defect or noncompliance is discovered or should have been discovered, routed through the dealer and distributor from whom the purchase was made, transportation charges prepaid.** MASCHIO GASPARDO shall complete such repair or replacement within a reasonable time after MASCHIO GASPARDO receives the product. THERE ARE NO OTHER REMEDIES UNDER THIS WARRANTY THE REMEDY OF REPAIR OR REPLACEMENT IS THE SOLE AND EXCLUSIVE REMEDY UNDER THIS WARRANTY.

THERE ARE NO WARRANTIES WHICH EXTEND BEYOND THE DESCRIPTION ON THE FACE OF THIS WARRANTY. MASCHIO GASPARDO MAKES NO OTHER WARRANTY, EXPRESS OR IMPLIED, AND MASCHIO GASPARDO SPECIFICALLY DISCLAIMS ANY IMPLIED WARRANTY OF MERCHANTABILITY AND/OR ANY IMPLIED WARRANTY OF FITNESS FOR A PARTICULAR PURPOSE.

MASCHIO GASPARDO shall not be liable for any incidental or consequential losses, damages or expenses, arising directly or indirectly from the product, whether such claim is based upon breach of contract, breach of warranty, negligence, strict liability in tort or any other legal theory. Without limiting the generality of the foregoing, MASCHIO GASPARDO specifically disclaims any damages relating to (i) lost profits, business, revenues or goodwill; (ii) loss of crops; (iii) loss because of delay in harvesting; (iv) any expense or loss incurred for labor, supplies, substitute machinery or rental; or (v) any other type of damage to property or economic loss.

This Warranty is subject to any existing conditions of supply which may directly affect MASCHIO GASPARDO' ability to obtain materials or manufacture replacement parts.

No agent, representative, dealer, distributor, service person, salesperson, or employee of any company, including without limitation, MASCHIO GASPARDO, its authorized dealers, distributors, and service centers, is authorized to alter, modify, or enlarge this Warranty.

For warranty services contact your selling dealer.

ALWAYS USE ORIGINAL SPARE PARTS



DEALER :



MASCHIO GASPARDO SpA
Sede legale e stabilimento produttivo
Via Marcello, 73 - 35011
Campodarsego (Padova) - Italy
Tel. +39 049 9289810
Fax +39 049 9289900
Email: info@maschio.com
www.maschionet.com

MASCHIO GASPARDO SpA
Stabilimento produttivo
Via Mussons, 7 - 33075
Morsano al Tagliamento (PN) - Italy
Tel. +39 0434 695410
Fax +39 0434 695425
Email: info@gaspardo.it

MASCHIO DEUTSCHLAND GMBH
Äußere Nürnberger Straße 5
D - 91177 Thalmässing - Deutschland
Tel. +49 (0) 9173 79000
Fax +49 (0) 9173 790079
dialog@maschio.de
www.maschionet.de

MASCHIO FRANCE Sarl
Rue Denis Papin ZA
F - 45240 La Ferté Saint Aubin
France
Tel. +33 (0) 2.38.64.12.12
Fax +33 (0) 2.38.64.66.79
info@maschio.fr

000 МАСКИО-ГАСПАРДО РУССИЯ
Улица Пушкина, 117 Б
404130 Волжский
Волгоградская область
Тел. +7 8443 203100
факс. +7 8443 203101
info@maschio.ru

MASCHIO-GASPARDO ROMANIA
S.R.L.
Strada Înfrăţirii, F.N.
315100 Chisineu-Cris (Arad) - România
Tel. +40 257 307030
Fax +40 257 307040
info@maschio.ro

MASCHIO GASPARDO
NORTH AMERICA Inc
112 3rd Avenue East
Dewitt, IA 52742 - USA
Ph. +1 563 659 6400
Fax +1 563 659 6405
info@maschio.us

MASCHIO IBERICA S.L.
MASCHIO-GASPARDO POLAND
MASCHIO-GASPARDO UCRAINA
GASPARDO-MASCHIO TURCHIA
MASCHIO-GASPARDO CINA
MASCHIO-GASPARDO INDIA