

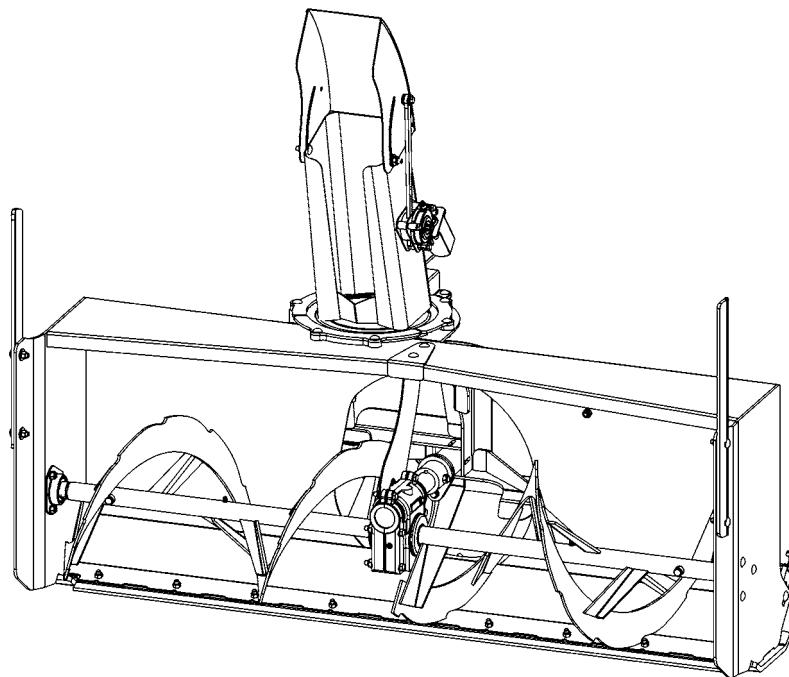

RADTECH
INNOVATION



OPERATOR'S AND PARTS MANUAL

54" SNOWBLOWER S1SB-54A

For John Deere Tractor Series 1: 1023E, 1025R

SERIAL NUMBER 22100000 AND UP

OM 0495SB-A
Rev0 06-21



INTRODUCTION

TO THE PURCHASER

All products are designed to give safe, dependable service if they are operated and maintained according to instructions. **Read and understand this manual before operation, and keep it in your files for further reference.**

This manual has been prepared to assist the owner and operators in the safe operation and suitable maintenance of the equipment. The information is applicable to products at the time of manufacture and does not include modifications made afterwards.

It is essential to read and understand this operator's manual before attempting to put equipment into service. Familiarize yourself with the operating instructions **AND ALL THE SAFETY RECOMMENDATIONS** contained in this manual and those labeled on the equipment and on the machine. Follow the safety recommendations and make sure that those with whom you work follow them.

TO THE DEALER

Give this manual to the owner upon delivery of the equipment.

TO THE PURCHASER AND THE DEALER

Illustrations

The illustrations may not necessarily reproduce the full detail and the exact shape of the parts or depict the actual models but are for reference only.

Direction Reference

All references to right and left, forward or rearward are from the operator seat looking at the implement.

To assist your dealer in handling your needs, please record hereafter the model number and serial number of your equipment and machine. It is also advisable to supply them to your insurance company. It will be helpful in the event that equipment or machine is lost or stolen

MODEL: _____

SERIAL NUMBER: _____

DATE OF PURCHASE: _____

DEALER NAME: _____

DEALER ADDRESS: _____

DEALER TELEPHONE NUMBER: _____

INTRODUCTION

All products are designed to give safe, dependable service if they are operated and maintained according to instructions. **Read and understand this manual before operation.** It is the owner's responsibility to be certain anyone operating this product reads this manual, and all other applicable manuals, to become familiar with this equipment and all safety precautions. Failure to do so could result in serious personal injury or equipment damage. If you have any questions, consult your dealer.

SAFETY FIRST

This symbol, the industry's "Safety Alert Symbol", is used throughout this manual and on labels on the machine itself to warn of the possibility of personal injury. Read these instructions carefully. It is essential that you read the instructions and safety regulations before you attempt to assemble or use this unit.



DANGER : Indicates an imminently hazardous situation which, if not avoided, will result in death or serious injury.



WARNING : Indicates a potentially hazardous situation which, if not avoided, could result in death or serious injury.



CAUTION : Indicates a potentially hazardous situation which, if not avoided, may result in minor or moderate injury.

IMPORTANT : Indicates that equipment or property damage could result if instructions are not followed.

NOTE : Gives helpful information.

TABLE OF CONTENTS

INTRODUCTION	1
TABLE OF CONTENTS.....	3
SAFETY INFORMATION.....	5
GENERAL SAFETY INFORMATION – Pictograms	7
SPECIFICATIONS.....	9
SAFETY LABELS	10
ESTIMATED ASSEMBLY TIME	11
ASSEMBLY	12
Snowblower Assembly.....	12
Installation of the electric deflector.....	13
Installation of the chute.....	14
Installation of the verticle knives	16
Installation of the hitch pins.....	16
Installation of electric harness # 4000174	17
Electrical diagram of the chute deflector	18
Installation of harness with fuse # 4000173	19
Installation of harness with fuse # 4000173	21
Installing the rotation sensor harness	24
OPERATION	27
SNOWBLOWER CONNECTION AND DISCONNECTION PROCEDURE.....	27
Lift control.....	27
Precautions to follow BEFORE each connection	27
Procedure for Connecting the Snowblower.....	28
Precautions to follow BEFORE each disconnection	31
Procedure for Disconnecting the Snowblower	31
PREPARATIONS	33

TABLE OF CONTENTS

OPÉRATION (continued).....	
OPÉRATION	34
Engine speed.....	34
Increased Adhesion and Stability.....	34
Engaging the drive Mechanism.....	34
Controls.....	34
ADJUSTMENTS	35
Adjustment of the Deflector.....	35
Adjustment of the Skid Shoes.....	35
Snow removal methods.....	36
MAINTENANCE	37
MAINTENANCE.....	37
Gear Box and Reduction Box.....	38
Oil Level - Filling	38
Oil change.....	38
Shear Bolts	39
Repositioning the Augers	39
Maintenance schedule	39
Problem : Hydraulic chute rotation is slow or does not turn	40
LUBRICATION.....	41
TROUBLE SHOOTING.....	42
STORAGE.....	43
PARTS	44
54 "Snow Blower - Rear.....	44
54 "Snow Blower - Front	46
Chute and Electric Deflector	48
Reduction Box – "4500184 and 4500228".....	50
Gear Box – "4500183"	51
Female driveline– "4700044"	52
WRRANTY	53
TORQUE SPECIFICATION TABLE.....	54
ADAPTER INSTALLATION PROCESS.....	55



SAFETY INFORMATION

Children

Tragic accidents can occur if the operator is not alert to the presence of children. Children are generally attracted to machines and the work being done. Never assume children will remain where you last saw them

1. Keep children out of the operating area and under the watchful eye of another responsible adult.
2. Be alert and turn machine off if children enter the work area.
3. Before and when backing, look behind for small children.
4. Never carry children while operating the machine. They may fall off and be seriously injured or interfere with the safe operation of the machine.
5. Never allow children to play on the machine or attachment even when the machine is turned off.
6. Never allow children to operate the machine even under adult supervision.
7. Use extra care when approaching blind corners, shrubs, trees, or other obstructions that might hide children from sight.

Before Operation

1. Read and understand both the machine AND implement operator's manual. Know how to operate all controls and how to stop the unit and disengage the controls quickly. Lack of knowledge can lead to accidents.
2. Park the machine/implement on level ground, set the parking brake, lower the implement to the ground, place all control levers in neutral, shut off the engine and remove the ignition key and allow the rotating parts to stop BEFORE making any implement adjustments, repairs or inspections.
3. Keep clear of all rotating parts. Do not put hands or feet under, or into snowblower and subframe with engine running.

4. For your safety, do not work under any hydraulically supported machine elements, they may creep down, suddenly drop or be accidentally lowered. Do not use loader, quick hitch, or an implement as a jack for servicing.
5. Do not operate the machine/implement that is defective or has missing parts. Make sure that all recommended maintenance procedures are completed before operating the unit.
6. Keep the machine/implement clean. Snow, dirt or ice build-up can lead to malfunction or personal injury from thawing and refreezing in garage. Inspect and clean every rotating parts.
7. Do not modify or alter this implement or any of its components, or any implement function without first consulting your dealer. The manufacturer will not claim responsibility for fitment of unapproved parts and/or accessories and any damages as a result of their use.
8. Verify that all machine/implement safety protective devices are in place. Shields, guards and covers must be correctly installed at all times. When necessary to remove these for servicing, cleaning, or repair work, they must be reinstalled immediately.
9. Always make sure all implement components are properly installed and securely fastened.
10. Check that all machine/implement drivelines are in good working order.
11. Check for moving parts excessive wear regularly. ALWAYS USE GENUINE PARTS WHEN REPLACEMENT PARTS ARE REQUIRED.
12. Prior to operation, clear work area and mark all curbs, pipes, etc. that cannot be moved.
13. Inspect the machine/implement after striking any foreign object to assure that all machine/implement parts are safe and secure and not damaged.
14. Handle fuel with care, as it is highly flammable. Use approved fuel container.
15. Never add fuel to a running engine or a hot engine.
16. Fill fuel tank outdoors with extreme care. Never fill fuel tank indoors. Replace fuel cap securely and wipe up spilled fuel. Always refuel using a properly grounded system.



SAFETY INFORMATION











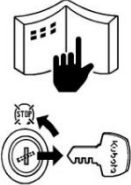

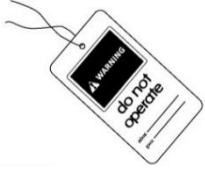
17. Check all machine controls regularly and adjust where necessary. Make sure that the brakes are evenly adjusted. Periodically check all nuts and bolts for tightness, especially wheel hub and rim nuts.
18. Make sure the machine is counterweighted and has tire chains for better traction and stability as recommended by your dealer. Weights provide the necessary balance to improve stability, traction and steering. Use only those recommended by your dealer.
19. Prolonged exposure to loud noise can cause impairment or loss of hearing. Wear a suitable hearing protective device such as earmuffs or earplugs to protect against objectionable or uncomfortable noises.
8. Park the machine/implement on level ground, place the transmission in neutral, set the parking brake, disengage the driving system, lower the equipment to the ground, place all levers including auxiliary control levers in neutral, shut off the engine and remove the ignition key **BEFORE LEAVING THE MACHINE.**
9. Always drive the machine at speeds compatible with safety, especially when operating over rough ground, crossing ditches, slippery surface or when turning.
10. Operate only with good visibility and during daylight hours, or when the area is well lit with bright artificial light.
11. Do not run the engine indoors except when starting engine and transporting attachment in or out of building. Carbon monoxide gas is colorless, odorless and deadly.

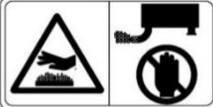
During Operation

1. Never allow anyone to operate the machine and implement until they have read the manuals completely and are thoroughly familiar with their basic operation. Lack of operating knowledge can lead to accidents.
2. Do not allow anyone to ride on the machine/implement at any time. The only one allowed is the operator that **MUST** sit in the driver seat.
3. Never allow anyone near the work area. The debris that can be thrown could cause serious personal injuries.
4. Never stand alongside of the implement while the engine is running.
5. Never operate the implement without safety protective devices in place. All machine/implement shields, guards and covers must be correctly installed at all times.
6. Keep clear of all rotating parts. Do not put hands or feet under, or into the implement with engine running.
7. If the implement starts to vibrate abnormally, disengage the PTO, stop the engine immediately and check for cause. Excessive vibration is generally a sign of trouble.
12. Exercise extreme caution when operating on or crossing a gravel drive, walks, or roads. Stay alert for hidden hazards or traffic.
13. Use extra caution when backing up.
14. Operate up and down (not across) intermediate slopes. Avoid sudden starts and stops. Drive machine backwards up steeper slopes with the implement off. Then operate as you travel down the slope.
15. Never park the machine on a steep slope. Do not attempt to operate on steep slopes. If operating on slopes is necessary, exercise extreme caution when changing direction.
16. Disengage power to implement when transporting or when not in use





GENERAL SAFETY INFORMATION

	<p>BEFORE YOU START SERVICE</p> <ul style="list-style-type: none"> • Read all instructions and safety instructions in this manual and on your machine safety decals. • Clean the work area and machine. • Park the machine on a stable and level ground, and set the parking brake. • Lower the implement to the ground. • Stop the engine, then remove the key. • Disconnect the battery negative cable. • Hang a "DO NOT OPERATE" tag in the operator station. 		<p>No Smoking or Open Flames while Fueling</p> <ul style="list-style-type: none"> • Fuel is extremely flammable and dangerous. Never smoke near fuel. If fuel is spilled on the machine, its engine, or electrical parts, it may cause a fire. If fuel is spilled, wipe it all up immediately. • Never smoke while filling the machine with fuel. And always tighten the fuel cap securely and wipe up any spilled fuel.
	<ul style="list-style-type: none"> • When performing maintenance on the equipment, hang the DO NOT OPERATE sign where it will be obvious from and around the driver's seat. • When performing maintenance or repairs, always lower attachments to the ground, stop the engine and secure the tracks with blocks. • When performing maintenance on the equipment, always disconnect the negative battery cable. • Before using tools, make sure you understand how to use them correctly and use tools in good condition and of the right size for the job. 		<ul style="list-style-type: none"> • Before getting on/off of the machine, clean off around the steps so there is no mud on them. Always give yourself 3-point support when getting on/off the machine. <p>CAUTION</p> <ul style="list-style-type: none"> • 3-point support means using both legs and one hand or both hands and one leg as you climb up/down.
	<p>START SAFELY</p> <ul style="list-style-type: none"> • Do not do the procedures below when you start the engine. <ul style="list-style-type: none"> - short across starter terminals - bypass the safety start switch • Do not alter or remove any part of machine safety system. • Before you start the engine, make sure that all shift levers are in neutral positions or in disengaged positions. • Do not start the engine when you stay on the ground. Start the engine only from operator's seat. 		<ul style="list-style-type: none"> • Do not remove the radiator cap when the engine operates, or immediately after it stops. If not, hot water can spout out from the radiator. Only remove the radiator cap when it is at a sufficiently low temperature to touch with bare hands. Slowly loosen the cap to release the pressure before you remove it fully.
	<p>Starting the Machine Safely</p> <ul style="list-style-type: none"> • Before starting the engine, always sit in the driver's seat and make sure the area is safe and clear. • As it is dangerous, never start the engine from anywhere but the driver's seat. • Always check and make sure control lever(s) are not engaged before starting the engine. • Never start the engine by hot-wiring the starter circuit. This is not only dangerous, but may damage the machine. 		<ul style="list-style-type: none"> • The engine, muffler, radiator, hydraulic line, etc., have parts that remain very hot even after the engine has been stopped. Be sure to avoid these parts, as touching them can result in burns. Radiator coolant, hydraulic fluid and oil also remain hot. Therefore, do not attempt to remove caps and plugs, etc., before these fluids have sufficiently cooled. • Make sure the coolant temperature has dropped sufficiently before opening the radiator cap. Also, since the inside of the radiator is pressurized, when removing the cap, first loosen it to release the pressure before removing the cap completely.
	<p>Starting the Machine Safely</p> <ul style="list-style-type: none"> • Wear clothes appropriate for working on equipment. Do not wear loose-fitting clothes as they may catch on the machine controls. • When working on the equipment, use all safety gear, such as a helmet, safety glasses and shoes, that are required by law or regulation. • Never perform maintenance while drowsy or under the influence of alcohol or drugs. 		<ul style="list-style-type: none"> • Grease is under high pressure inside the hydraulic cylinder. It is very dangerous to loosen a grease nipple quickly as it may shoot off. Always loosen grease nipples slowly. • And never face a grease nipple while loosening it.
	<p>Be Ready for an Emergency</p> <ul style="list-style-type: none"> • Keep a first-aid kit and fire extinguisher close at hand so you can use it when needed. • Keep emergency contact information for doctors, hospitals and ERs handy. 		<p>PREVENT A FIRE</p> <ul style="list-style-type: none"> • Fuel is very flammable and explosive under some conditions. Do not smoke or let flames or sparks in your work area. • To prevent sparks from an accidental short circuit, always disconnect the battery negative cable first and connect it last. • The battery gas can cause an explosion. Keep the sparks and open flame away from the top of battery, especially when you charge the battery. • Make sure that you do not spill fuel on the engine.
	<p>KEEP A GOOD AIRFLOW IN THE WORK AREA</p> <ul style="list-style-type: none"> • If the engine is in operation, make sure that the area has good airflow. Do not operate the engine in a closed area. The exhaust gas contains poisonous carbon monoxide. 		<p>Dispose of Waste Fluids Properly</p> <ul style="list-style-type: none"> • Never dispose of waste fluids on the ground, in the gutter, a river, pond or lake. Always dispose of hazardous substances like waste oil, coolant and electrolytic fluid in accordance with the relevant environmental protection regulations. • Keep the safety plates clean so they can be read. If a safety plate is damaged and comes off or becomes illegible, put a plate with the same warnings back in its place.

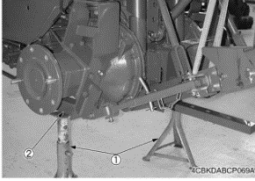

GENERAL SAFETY INFORMATION

	<ul style="list-style-type: none"> The pressure in the hydraulic circuit stays at pressure even after the engine stops. Before removing parts, such as hydraulic devices from the machine, first release the pressure. Please note that when releasing residual pressure, the machine itself and/or implements may move without warning, so be very careful when releasing the pressure. Oil gushing out under pressure is extremely dangerous as it may pierce your skin or your eyes. Similarly, oil leaking out of pinholes is not visible. So when checking for oil leaks, always wear safety glasses and gloves and use a piece of cardboard or a wood block to shield yourself from oil. 		<ul style="list-style-type: none"> When you need to access the underside of the machine for maintenance purposes, be sure to support the machine with a safety stand. Getting under the machine while supporting the machine by machine's own hydraulic cylinder or using a hydraulic jack can be extremely dangerous in the event of a hydraulic fluid leakage or similar mishap. <p>(1) Safety stand (2) Secure point for safety stand</p>
	<ul style="list-style-type: none"> Do not open a fuel system under high pressure. The fluid under high pressure that stays in fuel lines can cause serious injury. Do not disconnect or repair the fuel lines, sensors, or any other components between the fuel pump and injectors on engines with a common rail fuel system under high pressure. Put on an applicable ear protective device (earmuffs or earplugs) to prevent injury against loud noises. Be careful about electric shock. The engine generates a high voltage of more than DC100 V in the ECU and is applied to the injector. 		<ul style="list-style-type: none"> Whenever it is necessary to open the engine covers or hood in order to service the machine, always prop them open. If it is absolutely necessary to run the engine while working on the machine, make sure you are clear of all rotating or moving parts. Also take care not to leave anything, such as tools or rags, near any moving parts.
	<ul style="list-style-type: none"> Engage the loader control valve lock to prevent accidental actuation when the implement is not in use or during transport. Do not utilize the valve lock for machine maintenance or repair. Do not perform machine maintenance with loader in the air. If possible, follow loader instructions to remove loader before performing maintenance. If the machine has a backhoe, engage swing and boom locks. 		

SPECIFICATIONS

Specifications	S1SB-54A
Cutting width	54"
Cutting height (Frame only)	21"
Cutting height (Vertical knives)	31"
Length	35"
Simple/double auger	Single
Diameter of the auger	12 3/4"
Spiral auger thickness	0.135"
Fan diameter	15 3/4"
Fan width	5 5/8"
Diameter of the auger drive	1.38"
Number of fan blades	4
Tractor RPM	2 100
Fan RPM	840
Auger RPM	168
Drive shaft PTO	7 ^E
Skid shoes	Adjustable & replaceable 4 positions
Skid shoe material	Carbon steel
Thickness of the sides	3/16"
Snowblower botton thickness	12 Ga
Thickness of the contour of the tank	12 Ga
Fan contour thickness	12 Ga
Fan blade thickness	3/16"
Cutting edge	Replaceable, Steel CHT
Cutting edge dimension	1/4" x 2"
Parking stand	No
Type of hitch	4 pt hitch
Operating weight - hyd. Rotation. & deflector	290 lb
Approximate Shipping Weight	525 lb
Deflector adjustment (standard)	Electric with motor
Chute rotation (standard)	Hydraulic with motor
Type of chute	2 parts

SAFETY LABELS

IMPORTANT: Keep all decals clean and legible. Replace all missing, illegible, or damaged decals.

IMPORTANT: Decal placement locations shown are approximate; decals should not be placed in a location where the operator's field of view is impeded and should not cover any portion of other decals installed in the same vicinity.

INSTALLING OR REPLACING DECALS: Thoroughly clean the area where decal is to be placed using mild soap and water. Allow the surface to fully dry. Remove the backing from the decal, exposing the adhesive surface. Apply the decal to the recommended position shown in the diagram below and smooth out any bubbles.

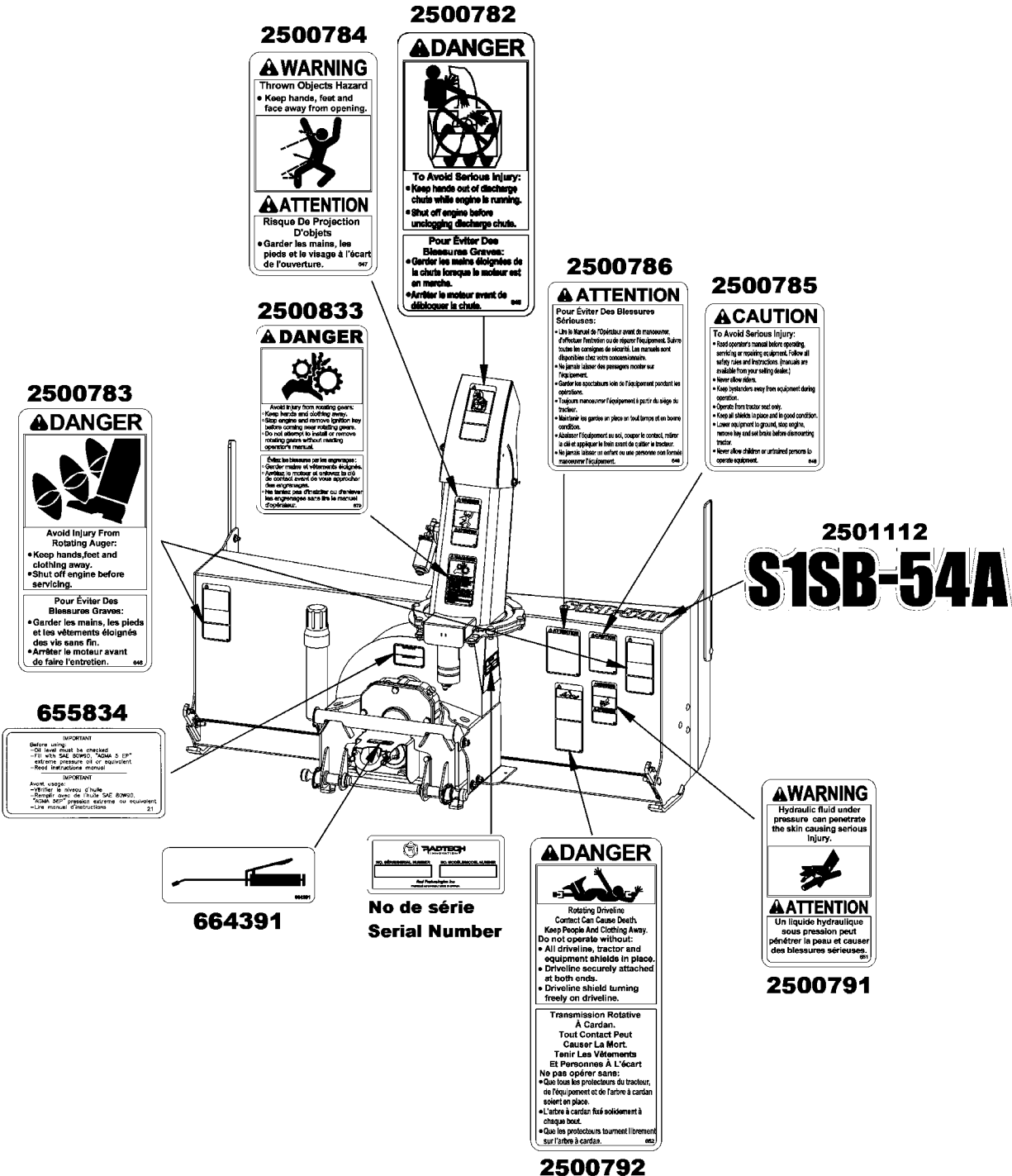

ESTIMATED ASSEMBLY TIME

Refer to the following table for the estimated assembly time to open the package and assemble the equipment and options.

	Snowblower 54" S1SB-54A
Estimated initial installation time	35 - 45 min
2nd installation step (on the tractor)	4 - 6 min

The assembly times of the table are only a reference under normal conditions according to the following assumptions:

1. The assembly is done by a competent person who is familiar with the equipment.
2. The following tools and materials are prepared:
 - Wrench set (flat wrenches)
 - Ratchet & socket set
 - Cutting pliers
 - Security gloves
 - Jack
 - Jack stand

ASSEMBLY

SNOWBLOWER ASSEMBLY

The snowblower is assembled at the factory, however, the chute must be assembled and installed. Before proceeding with assembly, separate all hardware according to their dimensions. When assembly is complete, and unless otherwise specified, tighten all bolts referring to the torque table located at the end of the manual.

TRACTOR PREPARATION

If applicable, remove the lawn mower from the tractor and front loader following the instructions in the tractor owner's manual.

IMPORTANT: The front loader and the subframe must never be installed simultaneously on the tractor.

LUBRICATION: Use a high-quality grease designated "extreme pressure" and containing molybdenum disulphide. This grease may specify "Moly EP" on its label.



WARNING

To avoid serious personal injury or death:

Read and understand SAFETY INFORMATION on previous pages before installation and operation. Perform all assembly with the assembly properly secured and supported.



WARNING

To avoid serious personal injury or death:

Park the vehicle on level ground, place the transmission in neutral, set the parking brake, place all control levers in neutral, shut off the engine, remove the ignition key and allow the rotating parts to stop **BEFORE** starting installation on the tractor.

ASSEMBLY

Installation of the electric deflector (Figure 1)

1. **Figure 1:** Apply a light layer of recommended grease to the teeth of the rack (item 1) and insert the rack inside the rack guide (item 2) as shown in the image on the left.
2. **Figure 1:** Fix the guide plate (item 5A), the rack guide (item 2), the three spacers (item 6), the second guide plate (item 5B) and the electric motor (item 4)) on the side of the chute (item 7) using the three 1/4"NC x 2" hex bolts (item 3) and the nylon insert locknuts (item 8).
3. **Figure 1:** Apply a light layer of recommended grease inside the hole in the rack (item 1) insert the $\varnothing 3/8"$ x $19/32"$ pivot bearing (item 10) and place two flat nylon washers (item 9A) between the deflector and the rack, in order to leave a slight play. Install the remaining nylon washers (item 9B) on the other side of the rack.

4. **Figure 1:** Secure using the 1/4"NC x 1 1/4" hex bolt (item 11), 1/4" flat washer (item 12), nylon washers (item 9B), $\varnothing 3/8"$ x $19/32"$ pivot pad (item 10), nylon washers (item 9A) and 1/4" nylon insert locknut (item 8) in the order shown.

N°	PARTS FIGURE 1	QTY
1	Rack	1
2	Rack guide	1
3	Hex bolt $\varnothing 1/4"$ NC x 2"	3
4	Electric motor	1
5	Guide plate	1
6	Spacer $\varnothing 3/8"$ x .721"	3
7	Chute	1
8	Nylon insert locknut $\varnothing 1/4"$ NC	4
9	Flat nylon washer $\varnothing 7/16"$	3
10	Pivot pad $\varnothing 3/8"$ x $19/32"$	1
11	Hex bolt $\varnothing 1/4"$ NC x 1 1/4"	1
12	Flat washer $\varnothing 1/4"$	1

IMPORTANT: The movements of the rack must not be hampered by the nylon washers (item 9).

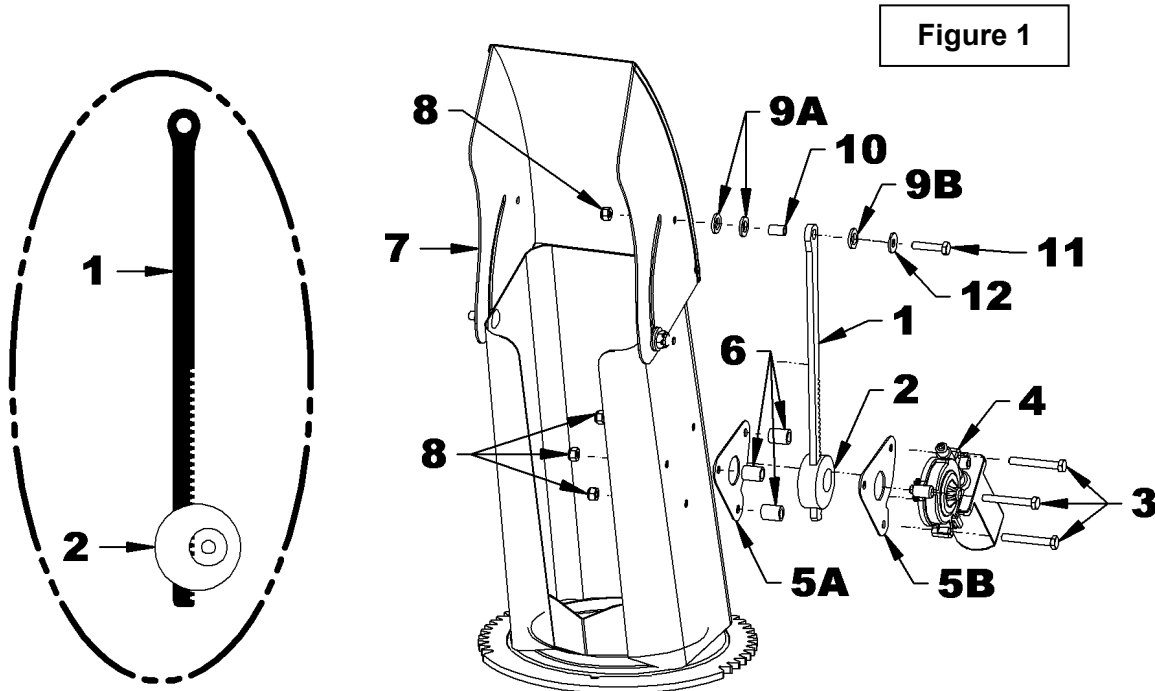

ASSEMBLY

Installation of the Chute (Figures 2-4)

- Figure 2:** Remove the gear protector (item 1) by removing the four nuts, lock washers, flat washer and bolts (items 2-3-4-5). Keep the parts on hand.
- Figure 3:** Grease the underside of the retaining plates (items 2-3) before installing them.
- Figure 3:** Place the rotation pad (item 9) over the outlet of the fan by placing the mark (item 9A) up and to the left of the snowblower, then place the chute (item 1) . Align the three 3/8" spacers (item 5) and the three 16ga spacers (item 10) with the six holes on the outlet of the fan and place the long retaining plate (item 2) at the front and the two short retaining plates (item 3) on the sides Secure each with two 5/16" x 1 1/4" lg carriage bolt (item 4) , flat washer , lockwashers and nuts (items 6-7-8)

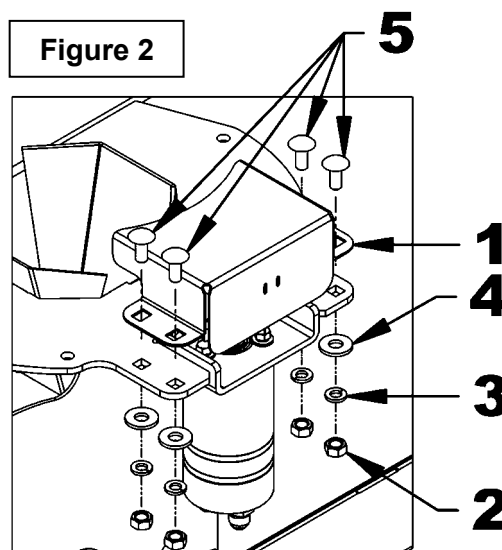

N°	PARTS FIGURE 2	QTY
1	Gear protector	1
2	Hex nut $\varnothing 5/16$ "NC	4
3	Lockwasher $\varnothing 5/16$ "	4
4	Flat washer $\varnothing 5/16$ "	4
5	Carriage bolt $\varnothing 5/16$ "NC x $\varnothing 3/4$ "	4

N°	PARTS FIGURE 3	QTY
1	Chute	1
2	Retaining plate -long	1
3	Retaining plate -short	2
4	Carriage bolt $\varnothing 5/16$ "NC x 1 1/4"	6
5	Spacer	3
6	Flat washer $\varnothing 5/16$ "	6
7	Lockwasher $\varnothing 5/16$ "	6
8	Hex nut $\varnothing 5/16$ "NC	6
9	Rotation ring	1
9A	Position indicator	-
10	Spacer	

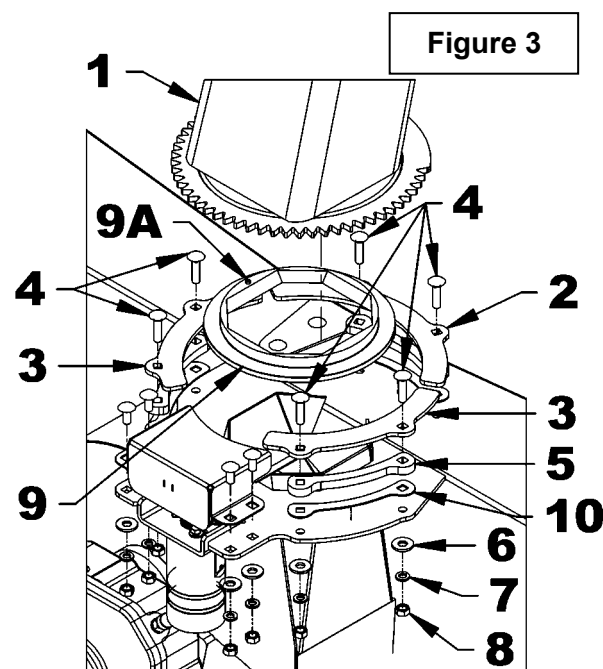

ASSEMBLY

4. **Figure 4:** If the motor gear (item 2) is not fully engaged in the teeth of the chute (item 3), loosen the two right bolts (item 4). Turn the hydraulic motor (item 1) so that the teeth of the gear (item 2) connect as much as possible with the teeth of the chute gear (item 3). Tighten the bolts (item 4) to a torque of 10 lb-ft (13 N-M). **Do not use the Torque Table at the end of the manual for these bolts.**

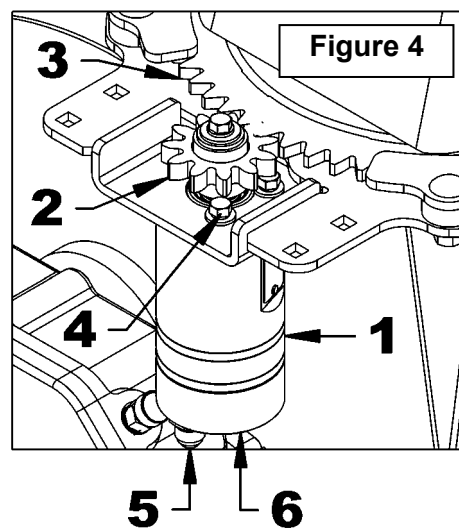

5. **Figure 4:** Install a green identification ring on the hydraulic hose (item 5), and install a yellow identification ring on the hydraulic hose (item 6). Position the identification rings as close as possible to the quick couplings.

NOTE: The two other identification rings will be installed while connecting the snowblower to the subframe.

N°	PARTS FIGURE 4	QTY
1	Hydraulic motor	1
2	Motor gear	1
3	Chute gear	1
4	Hex bolt. M6 x 1.00 x ø16mm PTD	3
5	Identification ring green	1
6	Identification ring yellow	1

6. **Figure 4a:** Place the gear protector (item 1) on the frame and secure with the four 5/16"NC x 3/4" bolts, flat washers, lockwashers and nuts (items 2, 3, 4, 5)

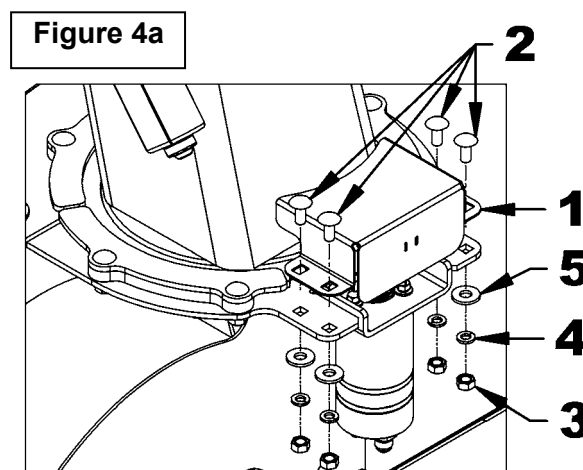

N°	PARTS FIGURE 4a	QTY
1	Gear protector	1
2	Carriage bolt ø5/16"NC x ø3/4"	4
3	Hex nut ø5/16"NC	4
4	Lockwasher ø5/16"	4
5	Flat washer ø5/16"	4

ASSEMBLY

Installation of the verticle knives (Figure 5)

1. Secure the vertical knives (item 1) to the right and left of the snowblower with two 5/16" x 1 1/4" carriage bolts (item 2), flat washers (item 3) and stover nuts (item 4) as shown.

N°	PARTS FIGURE 5	QTY
1	Verticle knives	2
2	Carriage bolts $\varnothing 5/16$ "NC x 1 1/4"	4
3	Flat washer $\varnothing 5/16$ "	4
4	Stover nut $\varnothing 5/16$ "NC	4

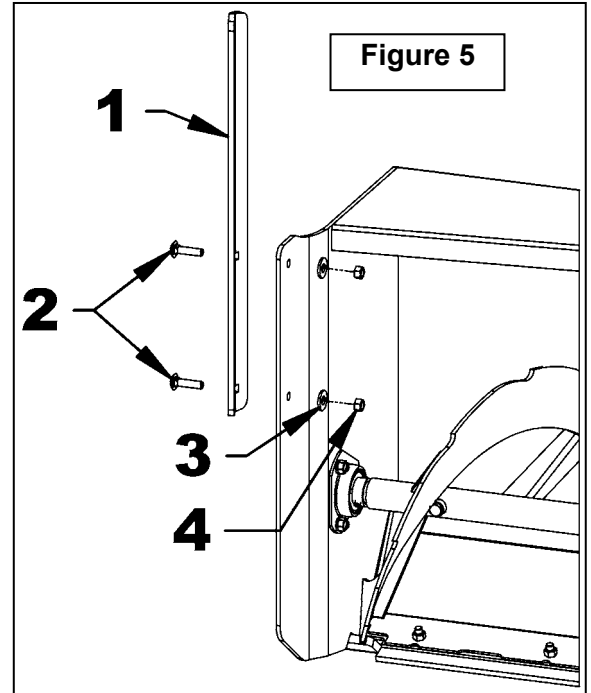

Installation of the hitch pins (Figure 6)

1. **Figure 6:** Insert each of the $\varnothing 1$ " x 3 7/8" pins (item 1) in the hole (item 2) on each side of the snowblower frame.
2. **Figure 6:** Insert each of the 1/4" round locking pins (item 3) into the hole (item 4) on each side of the snowblower frame.

N°	PARTS FIGURE 6	QTY
1	Pin $\varnothing 1$ " x 3 7/8"	2
2	Storage hole	-
3	Round locking pin $\varnothing 1/4$ "	2
4	Storage hole	-

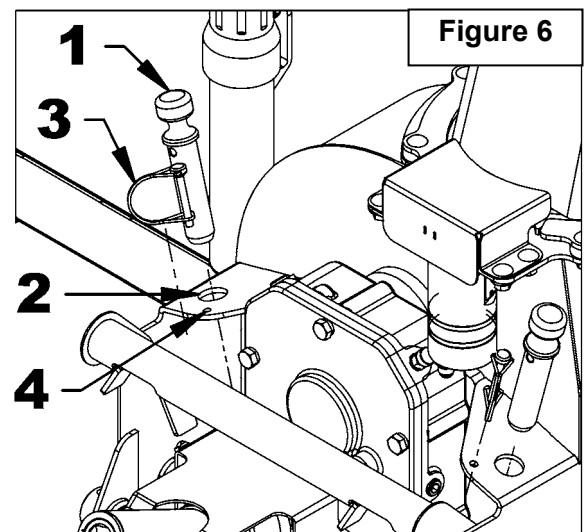

ASSEMBLY

Installation of Electric Rotation Harness # 4000174 (Figure 7)

1. **Figure 7:** Turn the chute all the way to the right and attach the female connector of the electrical harness for the deflector to the electric motor. Secure the harness (item 1) to the engine with a 1/4" x 15" nylon tie wrap (item 2) as shown in the figure.

IMPORTANT: Be sure not to over tighten the electrical harness with the nylon tie wrap.

2. Then cut the excess nylon tie wrap about 1/8" from the tie.
3. **Figure 7:** Secure the electrical harness (item 1) to the motor gear protector with the nylon tie wrap (item 3) already installed in the gear protector.

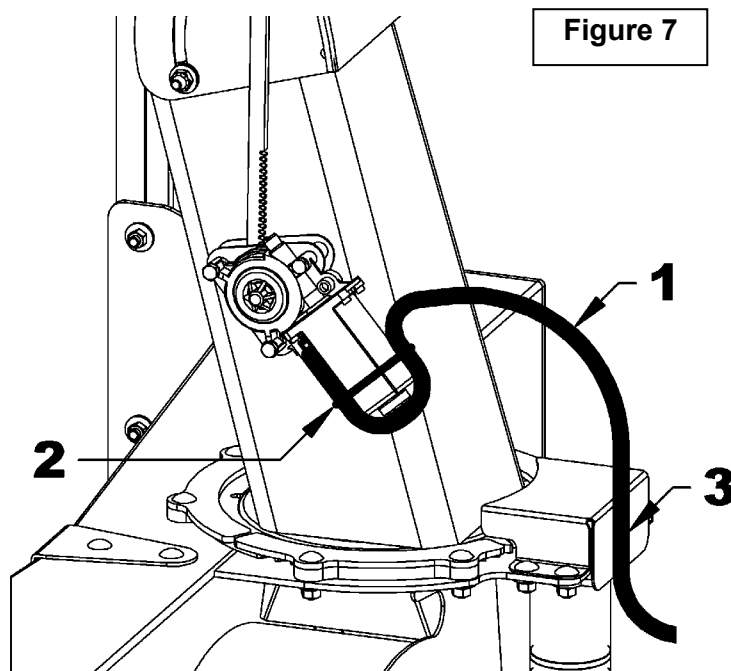

ASSEMBLY

Electrical diagram of the snowblowers electrical deflector

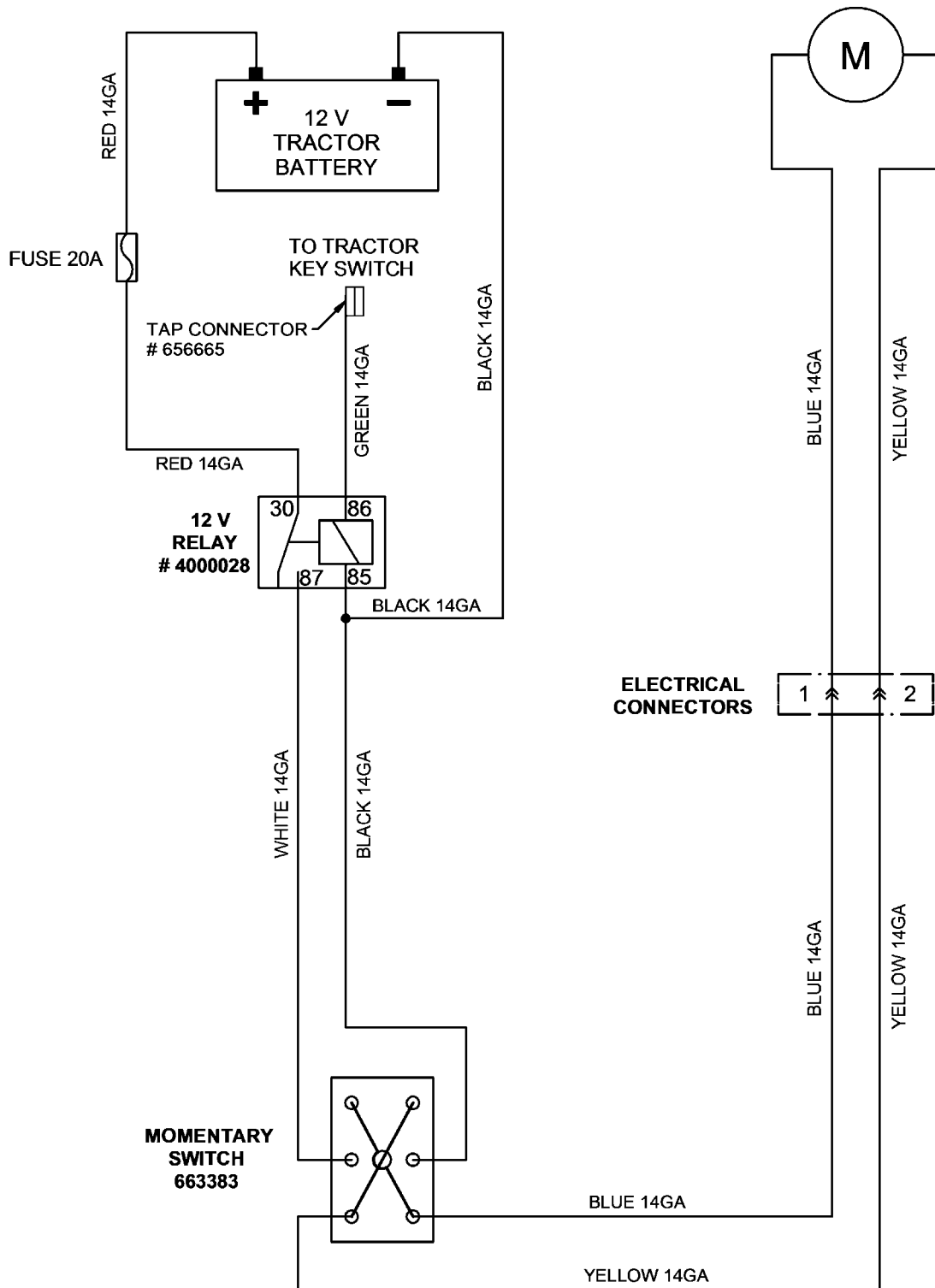

ASSEMBLY

Installation of Harness with Fuse # 4000173 (Figures 8-8a-8b)

1. Gather all the items listed in the table in figures 8.
2. **Figure 8:** Temporarily remove the fuse (item 7) from the harness fuse holder (item 5).
3. **Figure 8:** Attach the fuse wire (item 5a) to the positive (+) terminal of the tractor battery.
4. **Figure 8:** Secure the green wire connector to terminal 86 of the relay (item 1).
5. **Figure 8:** Secure the red wire connector to terminal 30 of the relay (item 1).
6. **Figure 8:** Secure the relay (item 1) to the tractor radiator plate using the round head screw # 8 32 x \varnothing 3/4" lg, the flat washer #8 (\varnothing 3/16" int.) and the nylon insert locknut # 8-32 (items 2, 3, 4).
7. **Figures 8, 8a, 8b:** Place the green wire (item 5b) in the location shown in the figure and follow the alternator wire (item 9) which passes on the left side of the tractor.
8. **Figures 8a, 8b:** Attach the green wire (item 5b) to the tractor red accessory wire (item 10) using the bypass connector (item 6).
9. **Figure 8b:** Secure the green wire (item 5b) to the alternator wire using a 4.8mm x 8" long nylon tie wrap (item 8).

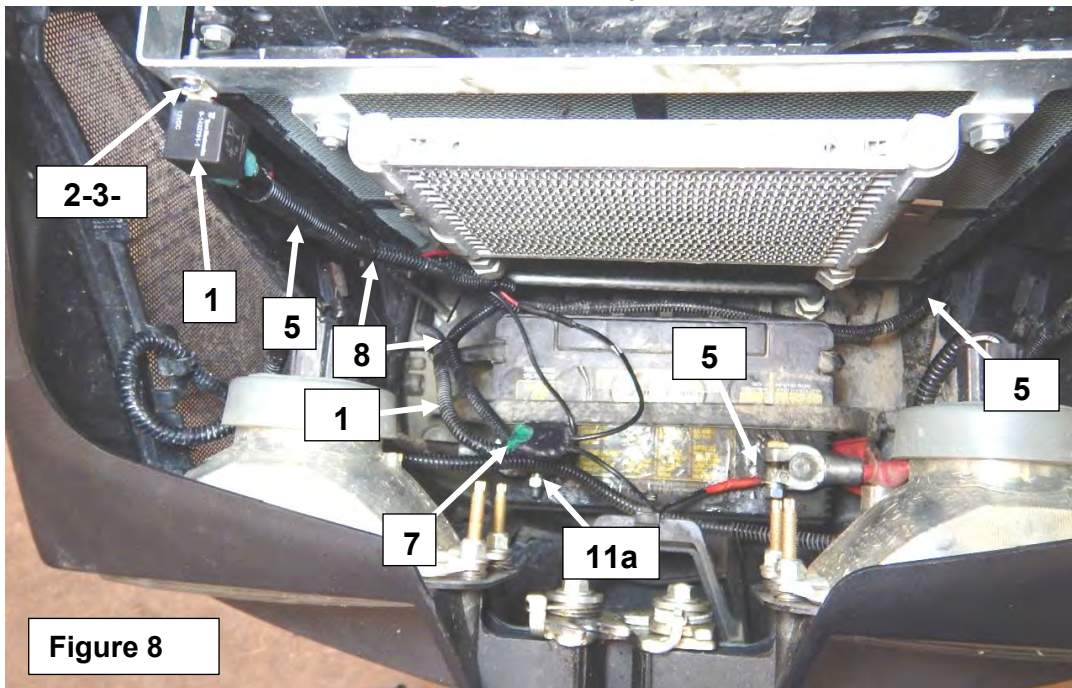
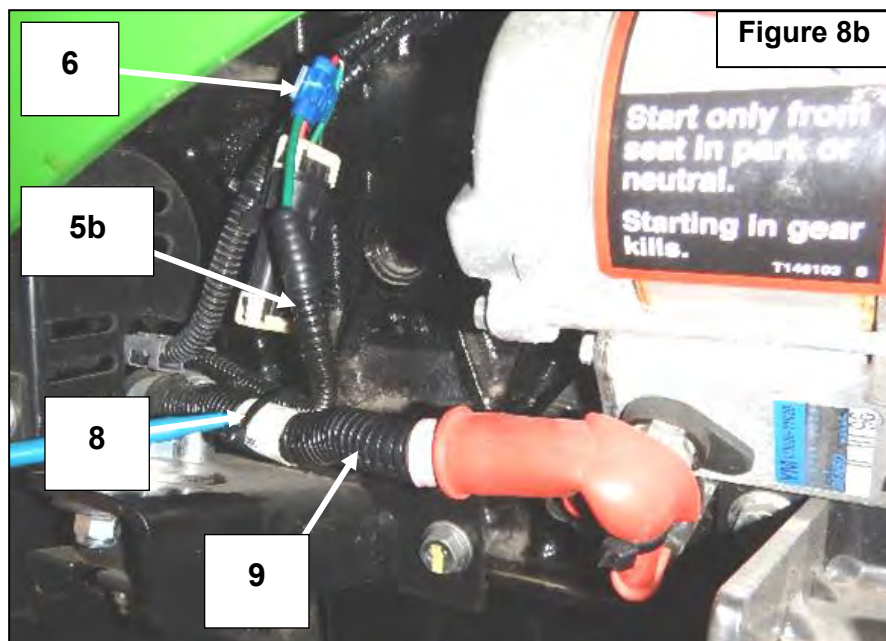
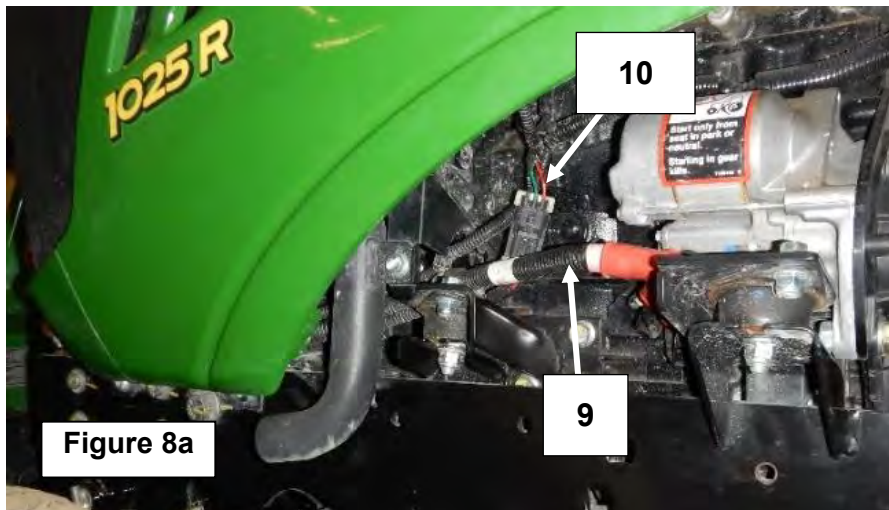

Figure 8

N°	PARTS FIGURES 8-8a-8b	QTY
1	12 volt relay	1
2	Round head screw #8-32 X \varnothing 3/4" Lg., PTD	1
3	Flat washer #8 (\varnothing 3/16" INT.)	1
4	Nylon insert locknut #8-32	1
5	Electric harness with fuse #4000173 (42 1/2" Lg)	1
6	Bypass connector	1
7	20A fuse (included with the harness)	1
8	Nylon tie wrap 4.8mm x 8" Lg.	3
9	Tractor alternator wire	---
10	Tractor red accessory wire	---
11	Main electrical harness # 4000203 (127 1/2"Lg.)	1

ASSEMBLY



Installation of Main Harness # 4000203 (Figures 8)

1. (Figures 8) Passing through the right side of the tractor, cross the section of the main electrical harness (item 11) which contains the black and white wires to the location of the tractor battery.
2. Figure 8: Secure the connector of the black wire (item 11a) to the negative (-) battery terminal and the second black wire to terminal 85 of the relay (item 1).

3. Figure 8: Secure the white wire connector to terminal 87 of the relay (item 1).
4. Figure 8-8b: Secure the harness with fuse (item 5) and the main harness (item 11) at the locations shown in figure 8b with two 4.8mm x 8" long nylon tie wraps (item 8).

ASSEMBLY

Installation of Main Harness # 4000203 (Figures 9) (continued)

5. Gather all the items listed in the table in figures 9.
6. **Figures 9, 9a:** Pass the main harness (item 11) in the places indicated in the figures and secure using two 4.8mm x 8" long nylon tie wraps (item 8).
7. **Figures 9b, 9c, 9d, 9e, 9f:** Pass the main harness (item 11) inside the tractor frame at the locations shown in the figures and secure with 4.8mm x 8" lg nylon tie wraps (item 8).

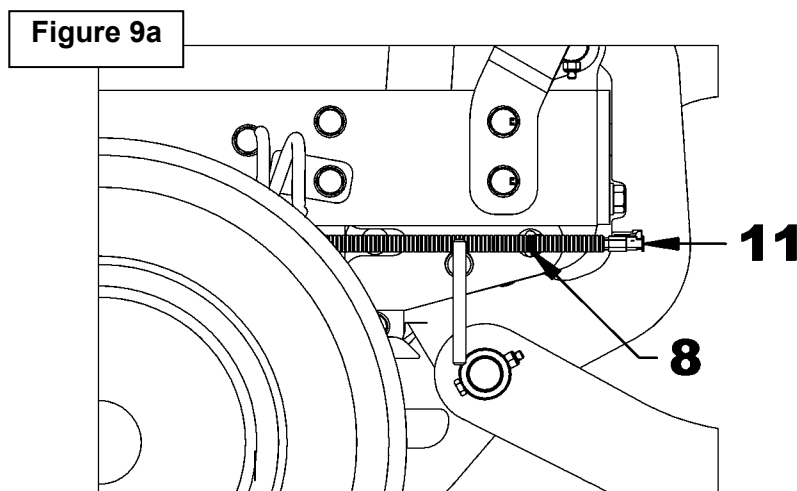
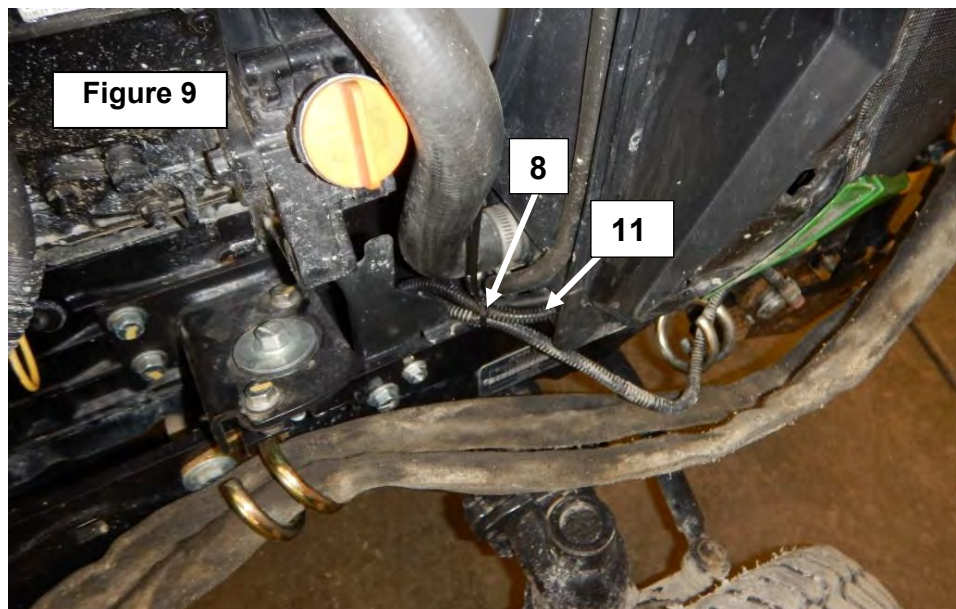

ASSEMBLY

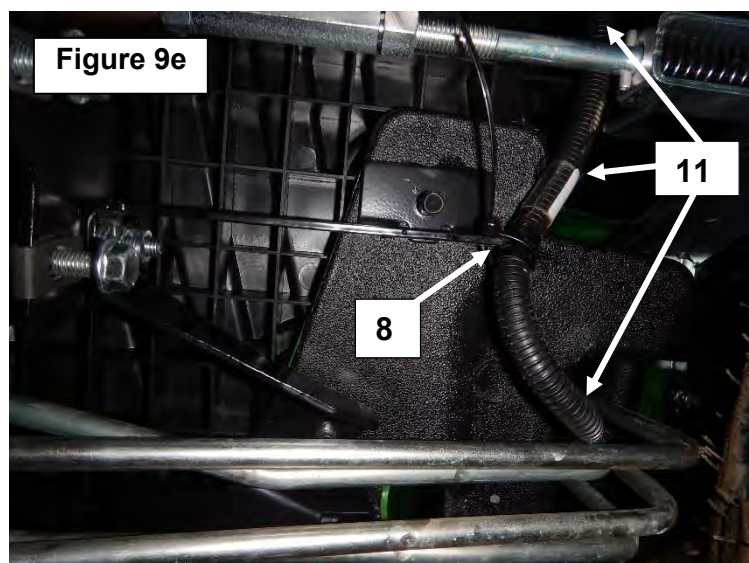
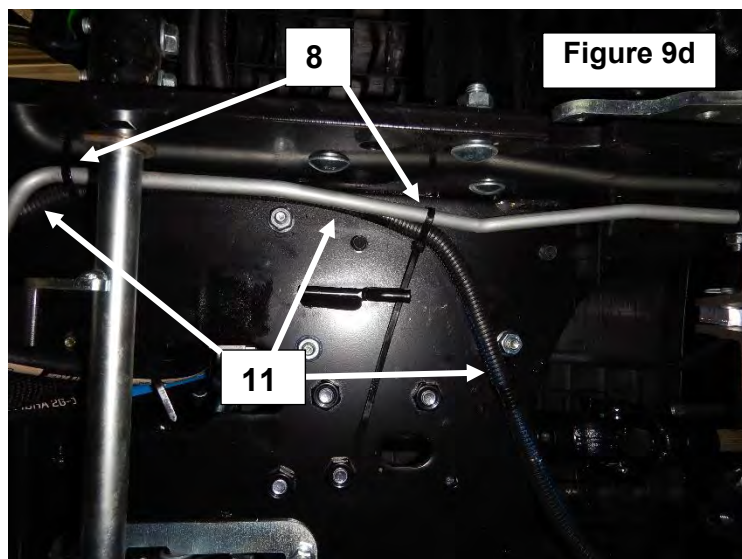
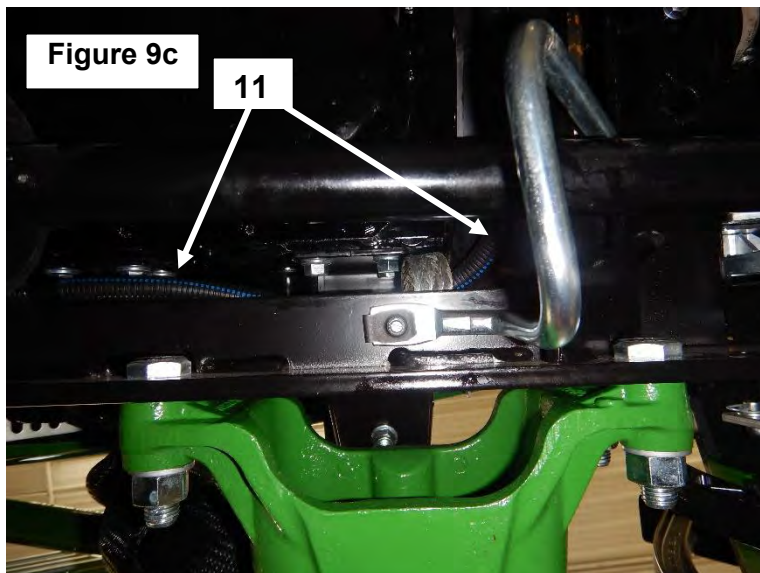
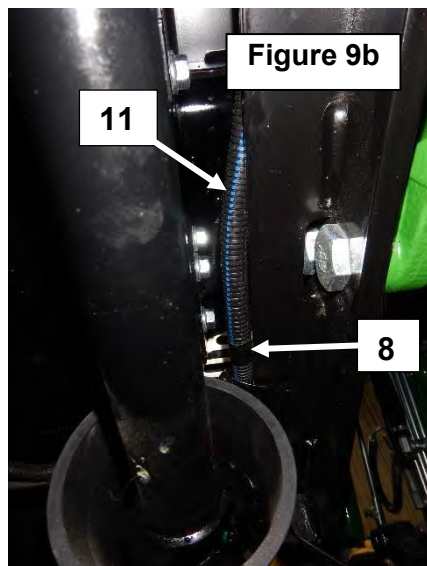

ASSEMBLY

8. **Figure 9f:** Pass the harness (item 11) outside the rubber sheath (item 12) of the tractor hydraulic control lever.

9. **Figures 9g, 9h:** Attach the connectors of the main electrical harness (item 11) to the switch connector (item 20). Attach the white wire connector to the switch 20A connector, the black wire to the 20B connector, the yellow wire to the 20C connector, and the blue wire to the 20D connector.

10. **Figure 9h:** Remove the nut (item 20E) from the switch (item 12) and secure the switch (item 12) to the switch box (item 13) using the nut on the switch box (item 20E).

11. **Figure 9h:** Attach the rubber cap for switch (item 18) to the switch (item 12).

12. **Figure 9h:** Secure the switch box (item 13) to the tractor hydraulic valve lever (item 14) using the housing clamp (item 15) and the two $\varnothing 1/4"$ lock washers. (item 16) and two hex bolts $\varnothing 1/4"$ NC x 1" lg. (item 17).

13. **Figure 9h:** Stick the chute deflector decal (item 19) in the location shown in the figure.

14. **Figure 9g:** Attach the main electrical harness (item 11) to the hydraulic control valve lever (item 14) using a 4.8mm x 8" lg nylon tie wrap (item 8).

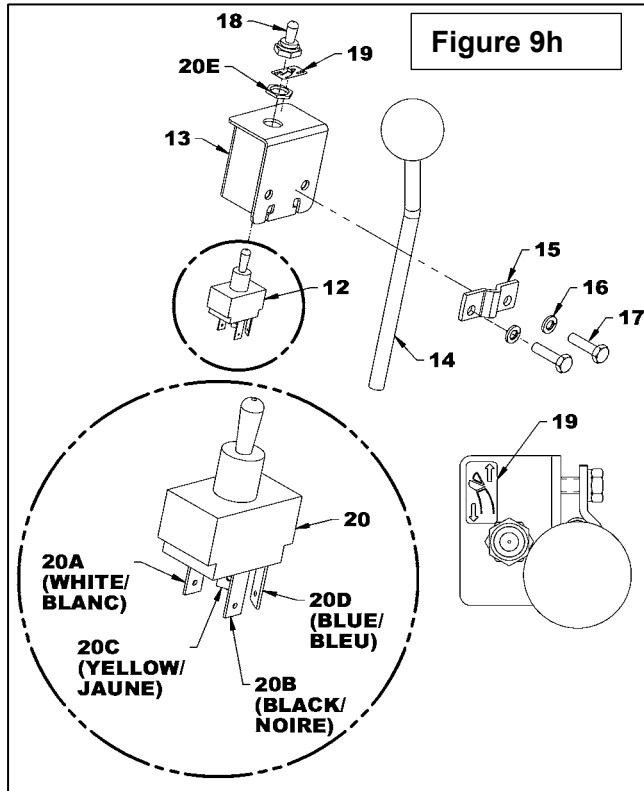
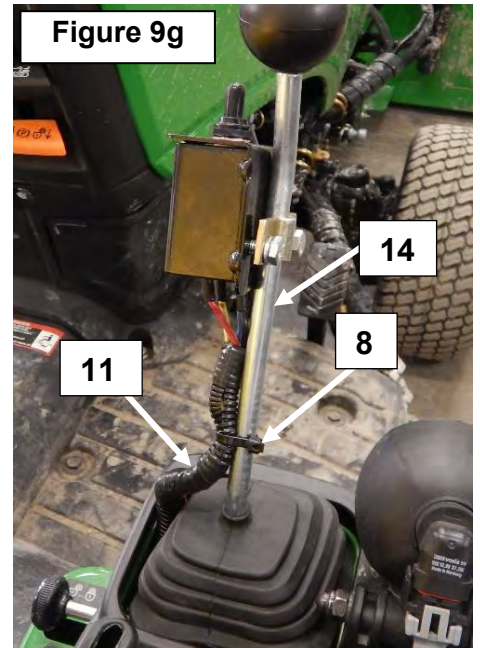
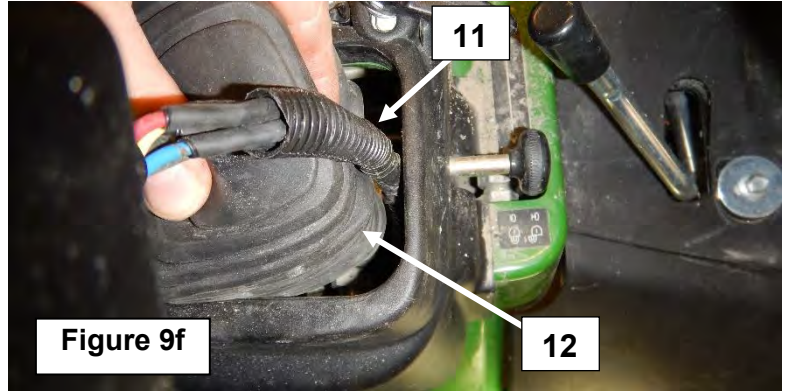

N°	PARTS FOR FIGURES 9f & 9g	QTY
8	Nylon tie wrap 4.8mm x 8" Lg	6
11	Main electrical harness #4000203 (127 1/2"Lg.)	1
12	Rubber sheath	---
14	Tractor hydraulic valve lever	---

N°	PARTS FOR FIGURE 9h	QTY
12	Switch	---
13	Switch box	1
14	Tractor hydraulic valve lever	---
15	Switchbox clamp	1
16	Lockwasher $\varnothing 1/4"$ PTD	2
17	Hex bolt $\varnothing 1/4"$ NC x 1" Gr.5 PTD	2
18	Rubber cap for switch	1
19	Decal « deflector decal »	1
20	4-blade electric switch	1

ASSEMBLY

Installing the Rotation Sensor Harness

NOTE: The rotation sensor and the **electrical extension harness** are not included with this product.

1. Gather all the items listed in the table in figure 10.
2. **Figure 10:** Secure the rotation sensor harness (not included) (item 1) at the location of the subframe shown in the figure using a 4.8mm x 8" long nylon tie wrap (item 2).
3. **Figure 10a:** Assemble the components of the protective cap, supplied with the snowblower, according to the figure.
4. **Figure 10b:** Secure the assembled protective cap (item 3) to the support reinforcement (item 4) using a 4.8mm x 8" long nylon tie wrap (item 2).
5. **Figure 10b:** Attach without tightening the electric extension harness (not included) (item 5) to the support reinforcement (item 4) using a 4.8mm x 8" lg nylon tie wrap (item 2a).

IMPORTANT: The extension harness (item 5) must be able to move in the nylon tie (item 2a).

Figures 10c: The connector of the extension harness (item 5a) must be attached to the protective cap (item 3) only when the subframe is removed from the tractor.

Figure 10d: The extension harness connector (item 5a) must be attached to the rotation sensor harness connector (item 1a) only when the subframe is installed on the tractor.

6. **Figure 10b:** Secure the extension electrical harness (item 5) to the metal tube using a 4.8mm x 8" lg nylon tie (item 2).

7. **Figure 10e:** Secure the extension electrical harness (item 5) at the location shown in the figure using a 4.8mm x 8" lg nylon tie wrap (item 2).

8. **Figure 10e:** Attach the extension harness connector (item 5b) to the tractor connector (item 6).

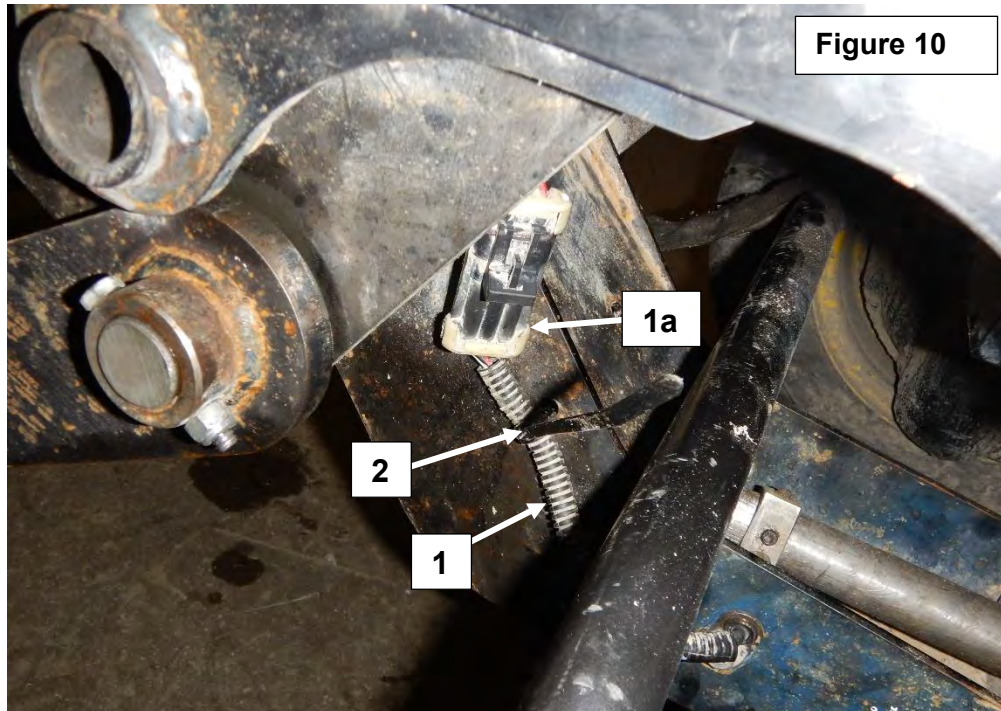

Figure 10

ASSEMBLY

Exploded view

Figure 10a

assembled view

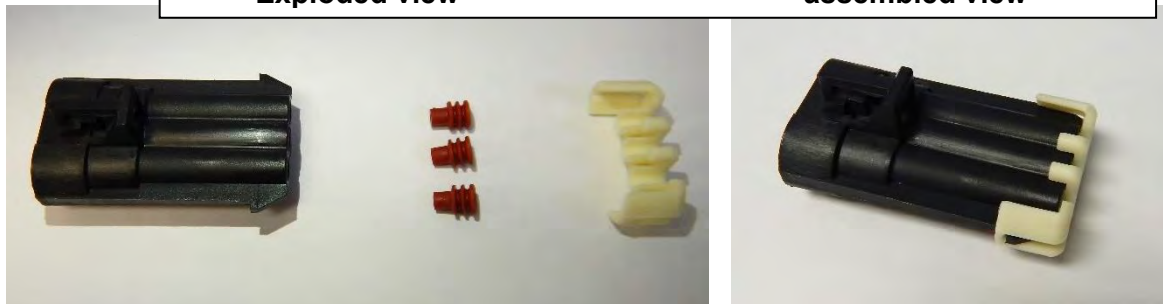

Figure 10b

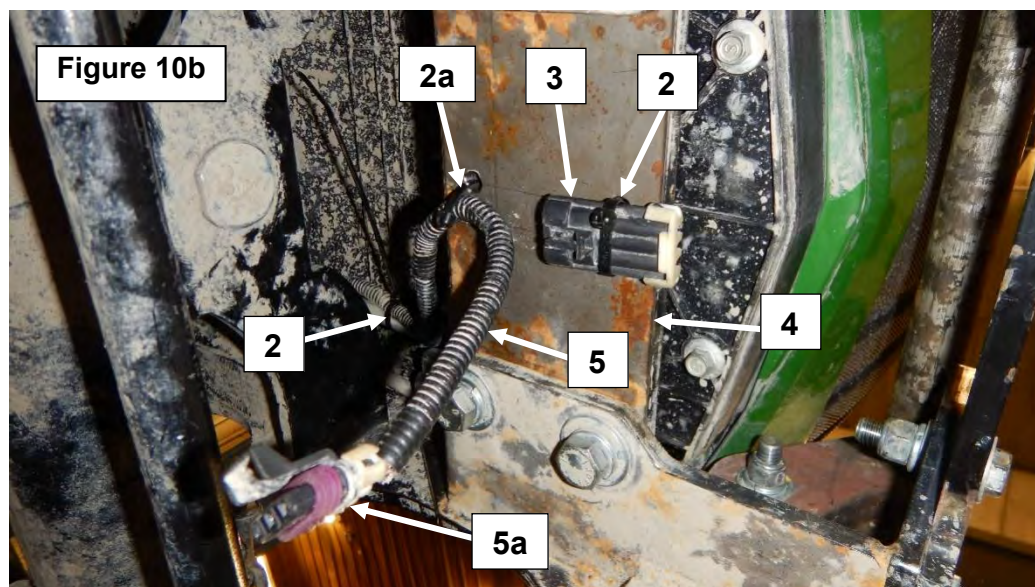
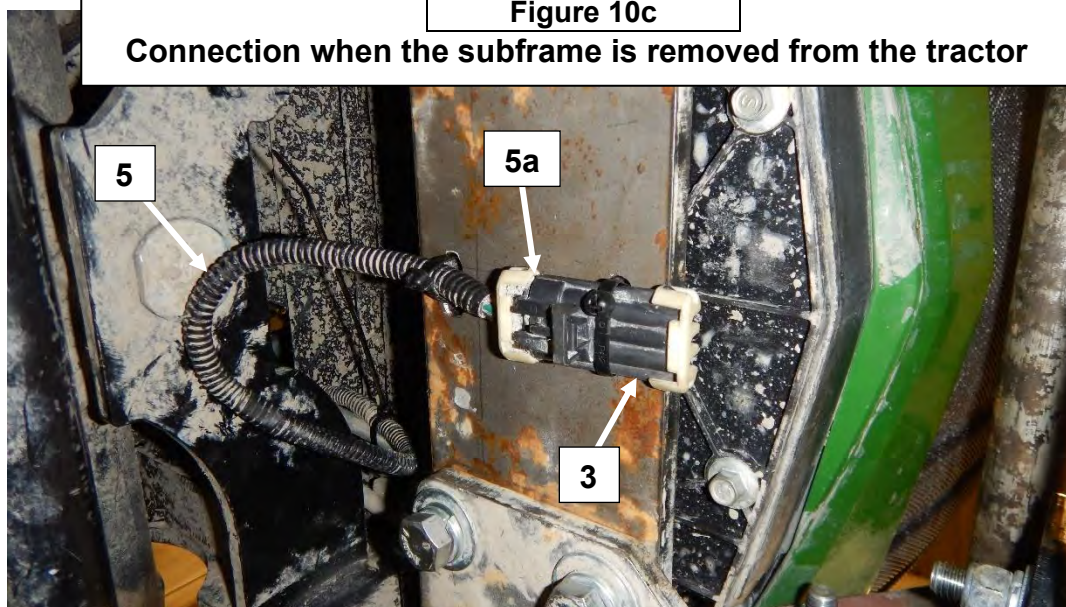

Figure 10c

Connection when the subframe is removed from the tractor



ASSEMBLY

Figures 10d

Connection when the subframe is installed to the tractor

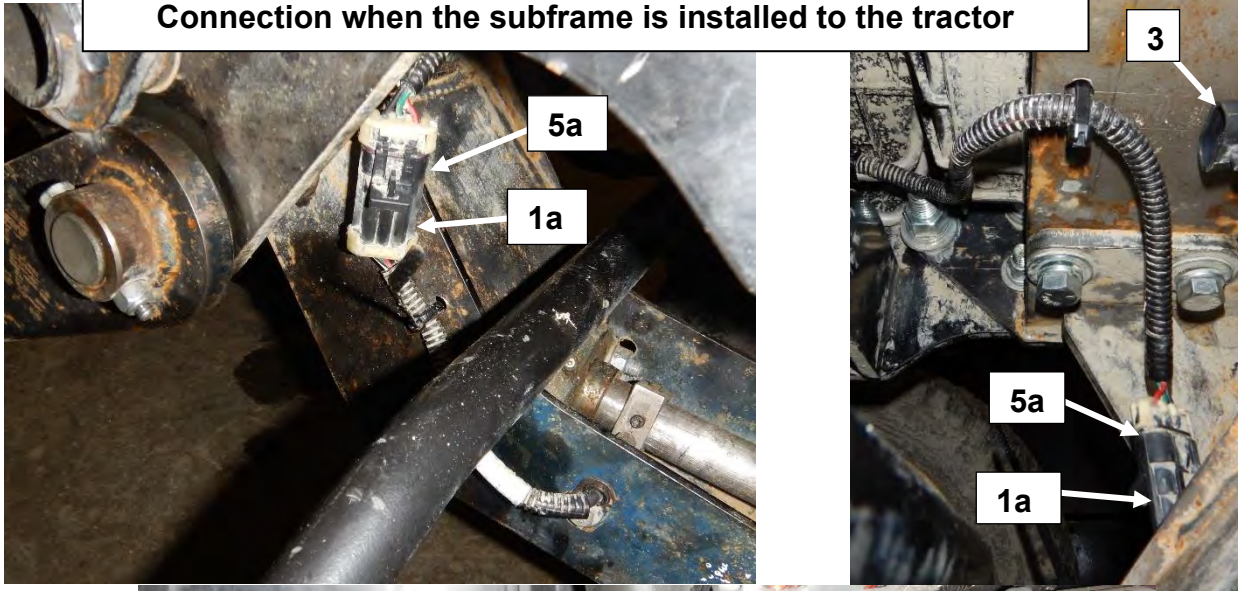
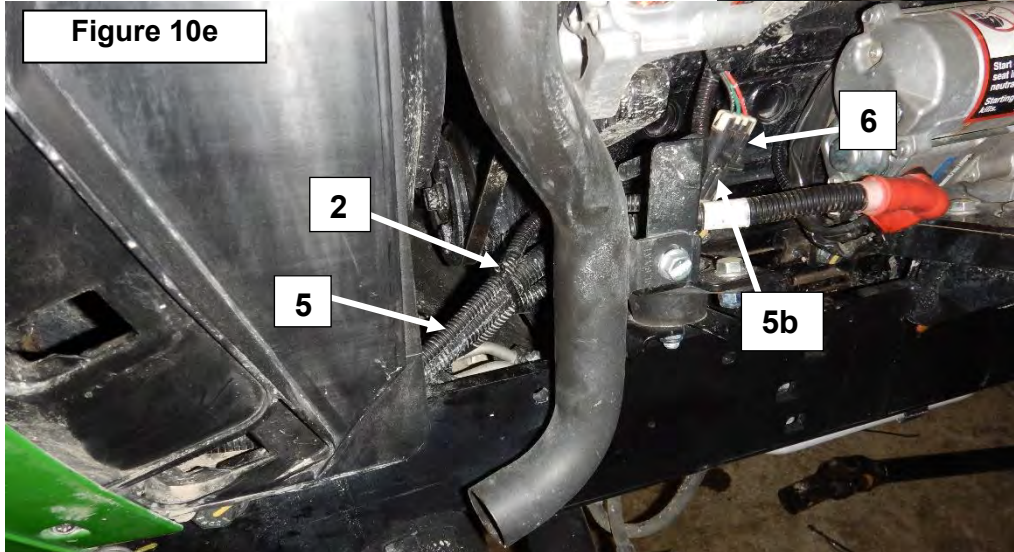

Figure 10e



N°	PARTS FOR FIGURES 10	QTY
1	Rotation sensor (not included) pn TA11587 order through JD	1
2	Nylon tie wrap 4.8MM X 8" Lg	5
3	Protective cap kit	1
4	Support reinforcement (installed at the front of the tractor)	-
5	Extension harness (not included)	1
6	Tractor electrical connector	-

OPERATION

SNOWBLOWER CONNECTION AND DISCONNECTION PROCEDURE

Note: It is necessary to connect the rotation sensor in order to be able to back up with the tractor when it is in operation with the snowblower.

⚠ WARNING: To avoid serious injury or death: Never activate the Mid PTO (Mid PTO) when the male hitch clutch lever is in the disengaged position and when there is no implements to mechanical drive installed.

Lifting control

The front loader hydraulic valve lever will be used to lift the male hitch and the snowblower installed on it.

- To LIFT the hitch and the snowblower, pull the valve lever.
- To LOWER the hitch, slightly push the valve lever.
- To place the snowblower in FLOAT mode, fully push the valve lever until it engages and stays in that position. Float mode allows the snowblower to follow the ground when the tractor is moving.

The use of the snowblower must be done in float mode. However, it is possible to temporarily lock the position of the snowblower in places where the snow has hardened such as road edges or compacted snow.

PRECAUTIONS to follow BEFORE each connection (Figure 11)

1. Make sure the environment is clear and free of any object that may interfere with the connection.
2. Make sure the maintenance of the 4-point hitch and equipment is up to date.
3. Make sure that the mechanical revolution of the snowblower is functional and that there is no residue, snow or ice that would prevent them from functioning.
4. Make sure that the drive shafts as well as the connection points of the two fasteners (items 1A, 1B, 2A and 2B) are clean and that they are not covered with snow or ice.
5. Make sure that the two snowblower hitch pins (item 3) and the two round locking pins (item 4) are properly located on the snowblower frame.
6. Make sure that the snowblower's half driveline (item 5) is properly installed on the "U" support (item 6) of the snowblower's protective guard.
7. Make sure that the half male driveline (item 7) is properly placed on top of the female hitch of the snowblower.
8. Observe and follow the safety precautions when operating the tractor.
9. Make sure that the mid PTO is not activated.

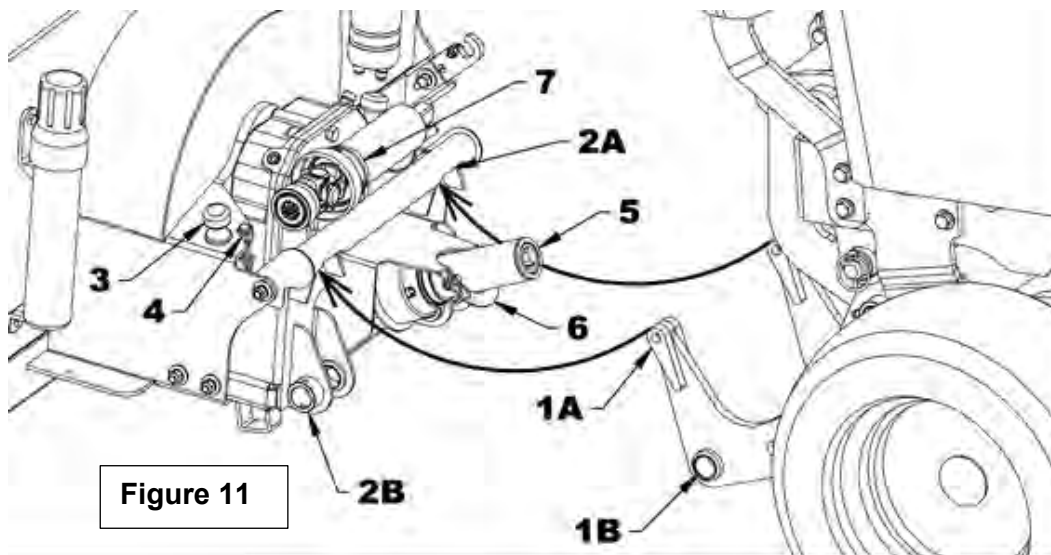

Figure 11

OPERATION

Procedure to follow to Connect the Snowblower (Figures 11 to 17)

It is important to follow these steps in the given order. **IMPORTANT: Read the "Precautions BEFORE Connection" on the previous page**

- **STEP 1: Figure 11:** Start the tractor, release the parking brake, drive slowly, making sure to align the female hitch on the snowblower with the male hitch on the tractor. Lower the male tractor hitch sufficiently so that the two upper points of the hitch (item 1A) fit into the tube openings (item 2A) of the female hitch of the snowblower.
- **STEP 2: Figure 11:** Using the tractor hydraulic control lever, lift the snowblower fully upwards in order to properly position the snowblower hitch with the male hitch on the tractor. This step will allow the bushings of the male hitch (item 1B) to align well with the bushings of the female hitch of the snowblower (item 2B)

⚠WARNING: To avoid serious injury or death, always activate the tractor hydraulic control lever lock, apply the parking brake and turn off the engine before dismounting the tractor to connect and disconnect equipment.

- **STEP 3: Figure 12:** Insert the two snowblower hitch pins (item 8) into the snowblower hitch bushings (item 9) and secure with the $\varnothing 1/4" \times 1 3/4"$ round locking pins (item 10).
- **STEP 4: Figure 13:** Remove the "U" support (item 11) which retains the female half driveline of the snowblower and secure it in the opposite direction (upwards) using the two 2.5mm x 40mm hair pins. (item 13)

IMPORTANT: The hairpins (Figure 13a, item 13) must be in the position shown in the figure.

- **STEP 5: Figures 14-15:** Place the male half driveline (item 14) below the subframe (item 16) in order to insert it into the female half driveline (item 15) of the snowblower. Then fix the male driveline (item 14) on the output driveline of the subframe (item 17). To do this, release the locking collar (item 14a) by moving it backwards and push on the fork (item 14b) to connect the driveline to the output driveline of the subframe (item 17). Release the fork and make sure that the locking collar has returned to its place. Pull and push on the male driveline (item 17) to make sure it is properly connected.

⚠CAUTION: To avoid serious injury or death: Make sure the quick coupler is properly connected. You should hear a "click" when connecting.

- **STEP 6: Figures 16-17:** Pass the hoses (item 1a and 1b) through the two hose supports (item 2) of the subframe and install the two identification rings according to the color of their other end. Then attach the hydraulic couplings and the snowblower's electrical connector to the hydraulic couplings and the tractor's electrical connector as shown in the figure. Finally, secure the two hoses with three nylon tie wraps (item 3) and the two hose protectors (item 4) at the locations shown in the figure.

IMPORTANT: Make sure the hydraulic couplings and electrical connectors are clean before connecting them

- **STEP 7:** Using the hydraulic control lever lower the snowblower to the ground.
- **STEP 8:** Adjust the engine revolution at low speed and activate the mechanical revolution. Increase the revolution gradually until the revolution is at full speed and start using the snowblower.

IMPORTANT: The clutch of the mechanical revolution must always be done at low speed so as not to damage the mechanical components.

OPERATION

Figure 12

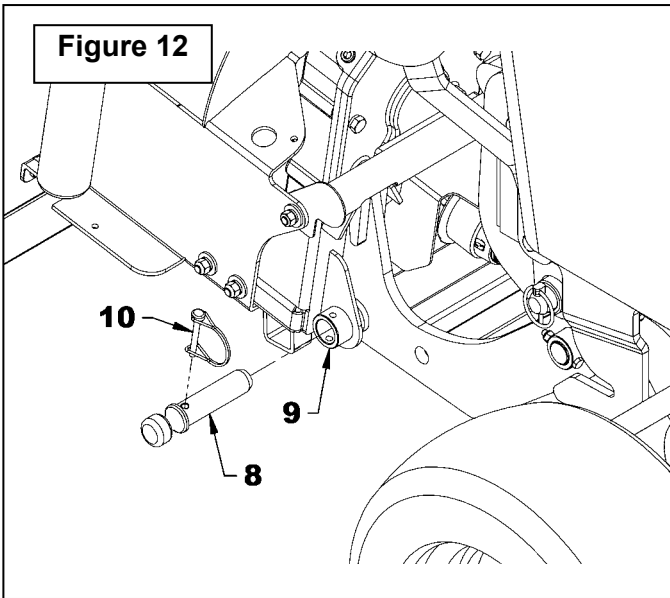

Figure 13

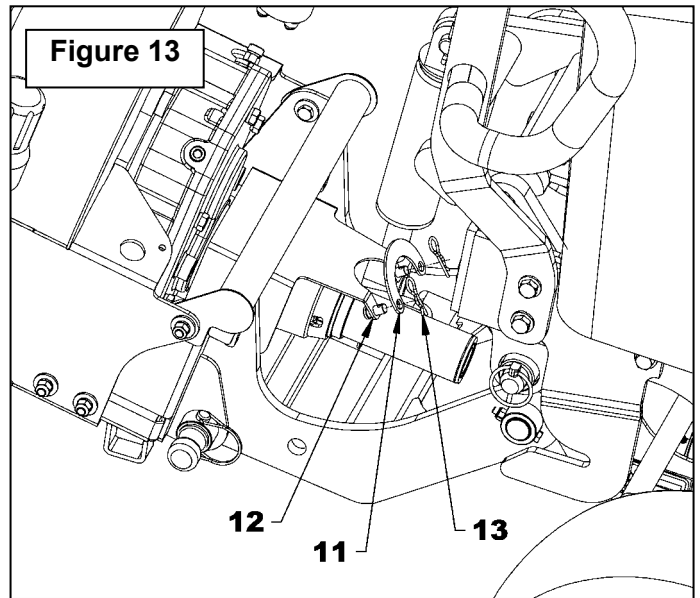
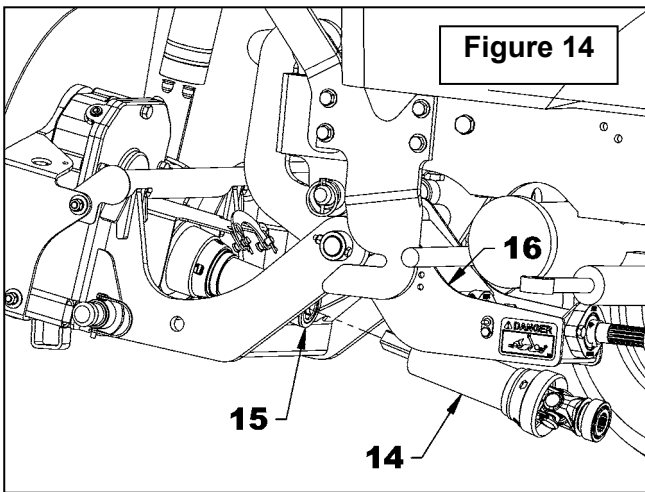

Figure 14



13

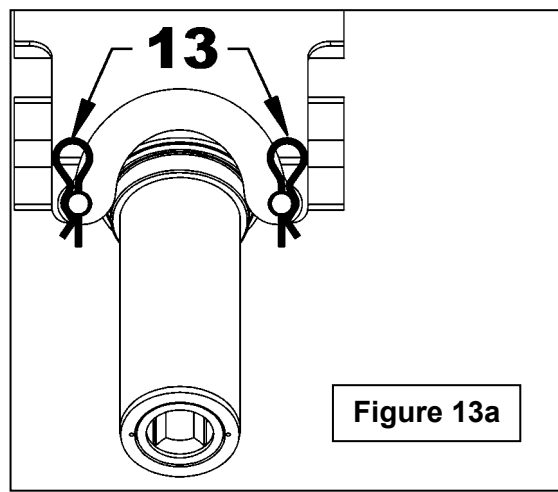
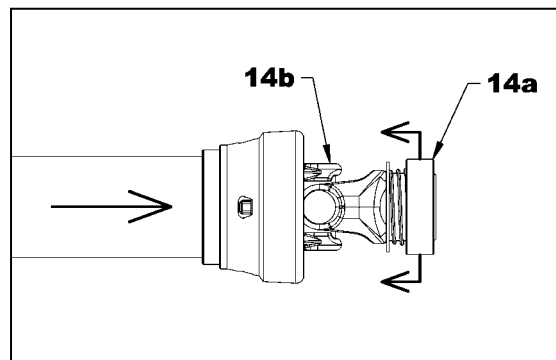
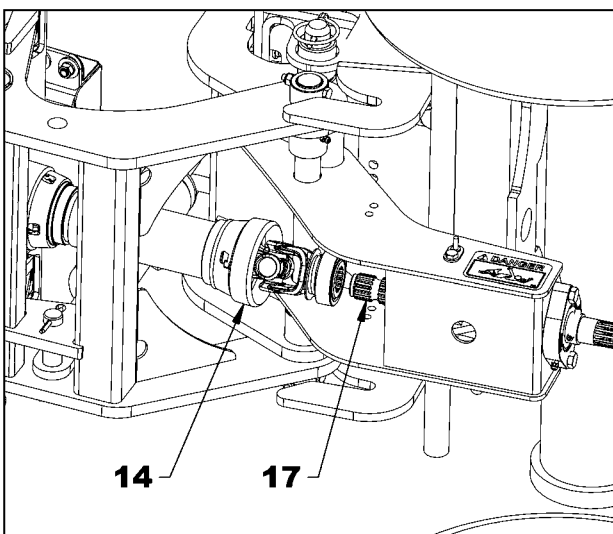
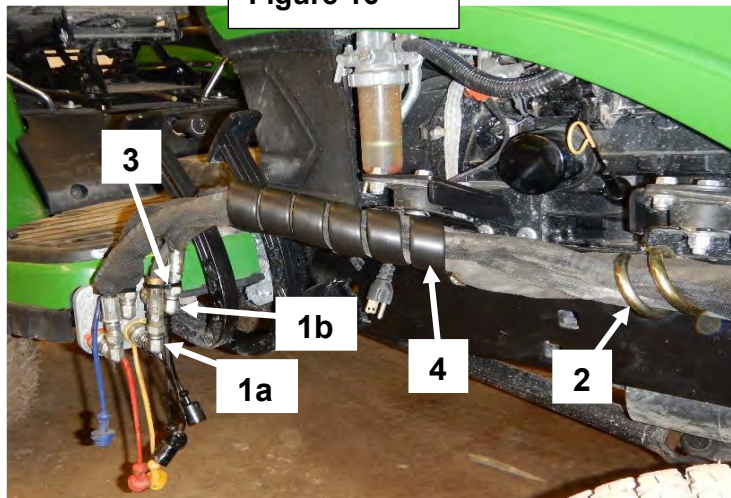
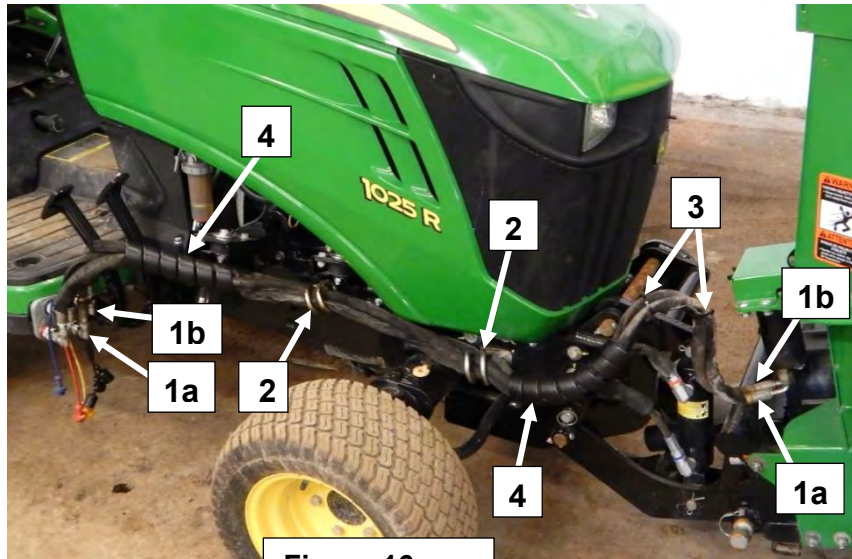

Figure 13a

Figure 15



OPERATION



Snowblower RAISED position

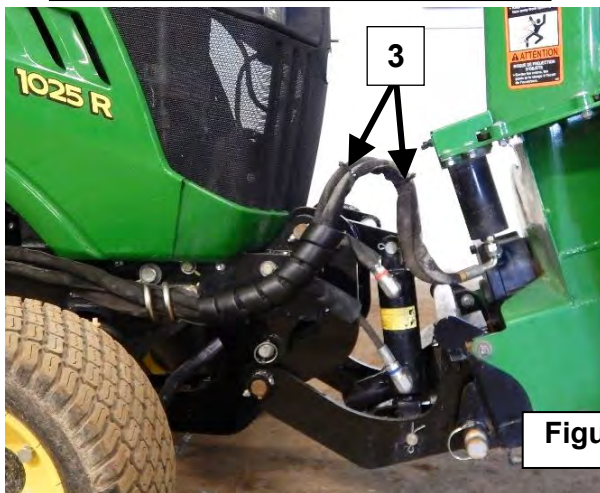

Snowblower LOWERED position

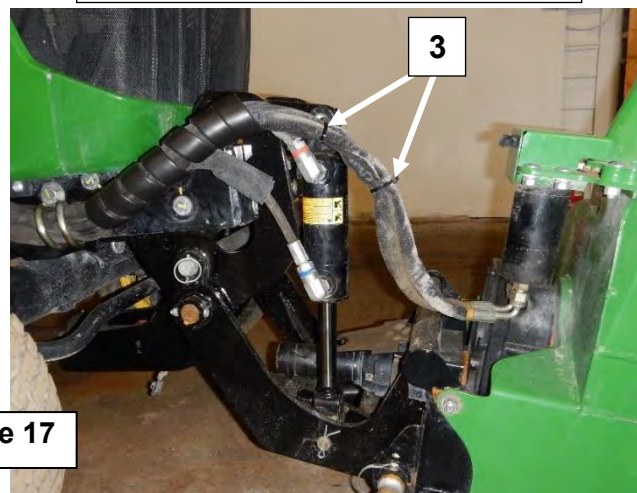

OPERATION

PRECAUTIONS to follow BEFORE each disconnection

1. Make sure that the environment is clear and free of any objects that could interfere with the disconnection.
2. Take all safety precautions when operating the tractor.
3. Make sure the mid PTO is not activated.

Procedure for Disconnecting the Snowblower (Figures 18 to 20)

It is important to follow these steps in the given order.

- **STEP 1:** Start the tractor and lift the snowblower fully up using the hydraulic control lever.

⚠ WARNING: To avoid serious injury or death, always activate the tractor hydraulic control lever lock, apply the parking brake and turn off the engine before dismantling the tractor to connect and disconnect any equipment.

- **STEP 2: Figure 18:** Disconnect the hydraulic couplings and electrical connectors, roll the hoses (item 1) and electrical wires together and place around the chute (item 2) of the snowblower as shown in the figure

- **STEP 3: Figures 19-20:** Disconnect and remove the male universal joint shaft (item 1) from the subframe and place it between the female hitch tube and the snowblower gearbox as illustrated in figure 20.

- **STEP 4: Figure 20:** Remove the "U" bracket (item 3) from the snowblower's protective guard and secure it in the opposite direction (downward) using the two 2.5mm x 40mm hairpins (item 13) in order to retain the female half driveline of the snowblower.

- **STEP 5: Figure 20:** Remove the $\varnothing 1/4" \times 1 3/4"$ round locking pins (item 5) and the two snowblower hitch pins (item 6) and place them in the appropriate holes in the snowblower frame.

- **STEP 6: Figure 20:** Slowly lower the snowblower to the ground using the tractor hydraulic control lever and unhook the male tractor hitch (item 7) from the snowblower hitch (item 8) by slowly backing up.



Figure 18

OPERATION

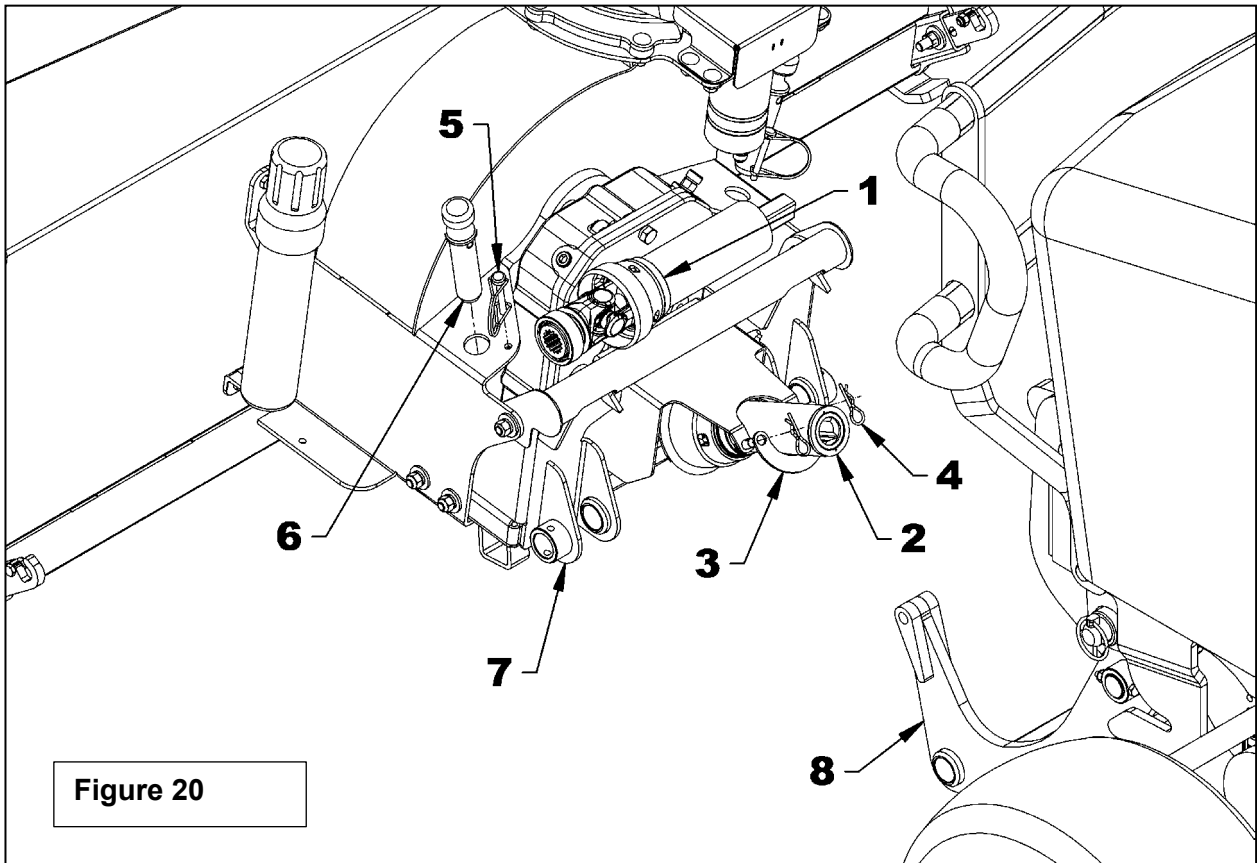
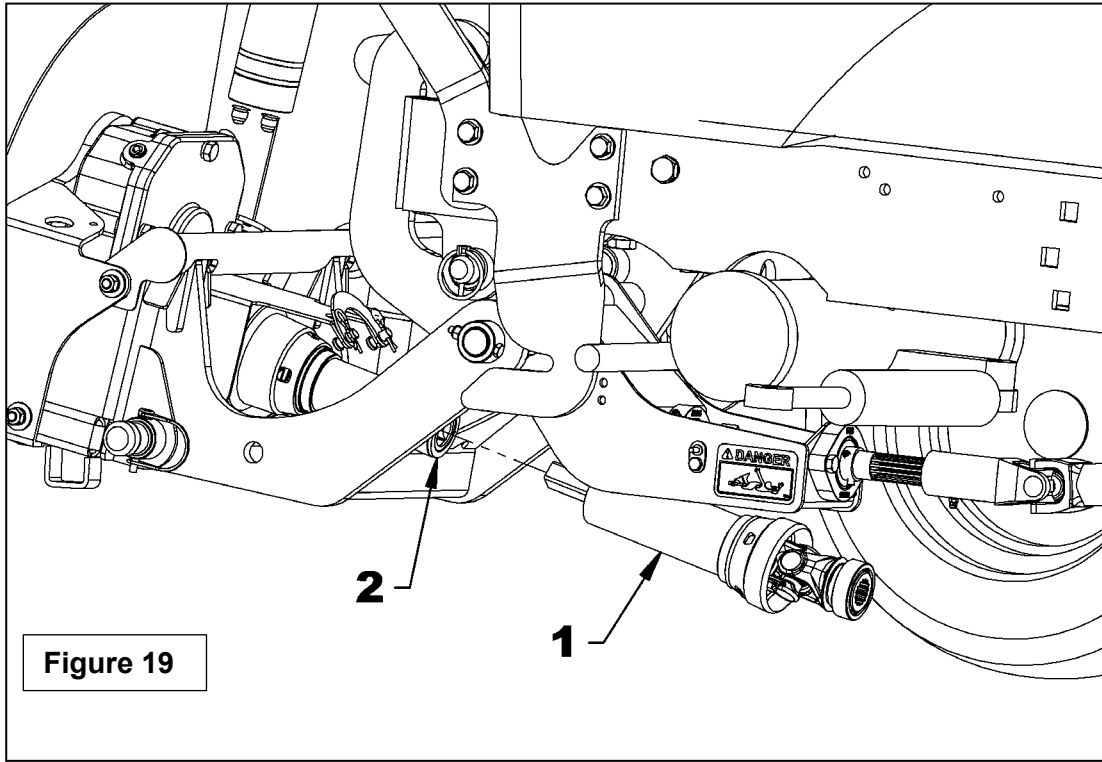

OPERATION

PREPARATIONS

1. Read the operator's manual carefully before using the tractor and snowblower. Be very familiar with the control systems and the proper use of the equipment. Know how to stop units and disengage control units quickly.
2. Wear adequate winter clothing when using the equipment.
3. Make sure the snowblower is cleared of snow and free of all material before starting the drive mechanism.
4. Make sure the auger and fan are free of obstructions and turn freely.
5. Check the oil level in the reduction box and, if necessary, add SAE 80W90, AGMA 5EP gear oil or equivalent.
6. Check the 3 shear bolts, one on each auger section and on the fan, for proper tightness.
7. Adjust the skid shoes to level so that they slide properly.
8. Start the tractor and idle the tractor BEFORE engaging the snowblower.
9. Operate the snowblower at maximum speed.



CAUTION: To avoid serious injury: Never use your hands to unblock the chute . Use a 36 "(925mm) long stick or plank. Do not attempt to clear a chute blocked with snow when the engine is running. If the chute jams, stop the tractor engine, remove the ignition key and then clear the chute.



WARNING: To avoid serious injury or death:

- Do not allow people to stay near the work area.
- Do not allow anyone to climb on the equipment or the quick hitch.
- Before cleaning, adjusting or repairing the equipment, bring the tractor to a complete stop, wait for all moving parts to stop, apply the brakes, lower the equipment to the ground, switch off the engine and remove the ignition key.
- Do not place any part of your body under the equipment during adjustments.



WARNING

Always operate the equipment from the operator's seat. Never allow anyone to climb on the machine.



WARNING

Operate the equipment at a speed that matches the working conditions. Be very careful when working near an embankment or on uneven ground.



WARNING

Always wear safety glasses when using any equipment.

OPERATION

OPERATION

Engine speed

1. Start the tractor. Allow the engine to warm up for at least one minute, then engage the drive mechanism and gradually increase the engine speed.
2. Make sure the snowblower head is properly positioned and start the drive mechanism.
3. Adjust ground speed as needed. For maximum power, run the engine at or near full throttle.

IMPORTANT: Use the maximum revolution speed when clearing snow with wet and/or sticky snow. Too low a revolution speed will tend to obstruct the chute.

Increased Adhesion and Stability



WARNING: To avoid serious injury or death:

Always make sure the tractor is using a 350 lbs rear counterweight that provides the balance necessary to prevent overturning, loss of traction or steering.

Engaging the Drive Mechanism

See the Tractor Operator's Manual for operating instructions.

Controls

The front loader hydraulic valve lever is used to lift the male hitch and the attachments to be installed on it.

- To LIFT the hitch and equipment, pull the valve lever.
- To LOWER the hitch, slightly push the valve lever.
- To place the equipment in FLOAT mode, fully push the valve lever until it engages and remains in this position. Float mode allows implements to follow the ground perfectly when the tractor is in motion.
- To orient the chute to the LEFT, push the valve lever slightly to the left.
- To orient the chute to the RIGHT, push the valve lever slightly to the right.

IMPORTANT: The snowblower must always be used in the float mode.

However, it is possible to momentarily lock the position of a snowblower in areas where the snow has hardened such as on road edges or compacted snow.

OPERATION

ADJUSTMENTS

⚠ CAUTION: To avoid serious injury or death: Make sure the engine and all equipment components are completely stopped, and the drive mechanism is turned off **BEFORE** making any adjustments.

Adjustment of the Deflector

The angle of the deflector must be adjusted so that the snow is sent to the correct distance.

- To adjust the angle of the deflector UP, pull the switch back.
- To adjust the angle of the deflector DOWN, push the switch forward

Adjustment of the skid shoes

Adjust the snowblower so that the skid shoes slide level with the ground and take into account the terrain conditions, so that the snowblower does not send back gravel or rocks with the snow. Make sure they are at the same height so that the cutting edge is leveled.

To adjust the skid shoe (item 1), remove the $\varnothing 3/8$ " NC hex nut (item 2), lock washer (item 3), flat washer (item 4) and the $\varnothing 3/8$ " NC x 1 3/4" carriage bolt (item 5). Secure with the hardware (items 2-3-4-5) in the appropriate hole according to the following settings.

Distance between the cutting edge and the ground surface:

At level paved surface:

1st adjustment - the bottom hole of the skid shoe in the bottom hole of the frame.

2nd adjustment - from the center of the skid shoe into the hole on the top of the frame.

Uneven surface or gravel:

1st adjustment - from the center of the skid shoe into the hole in the bottom of the frame.

2nd adjustment - from the top of the skid shoe into the hole on the top of the frame.

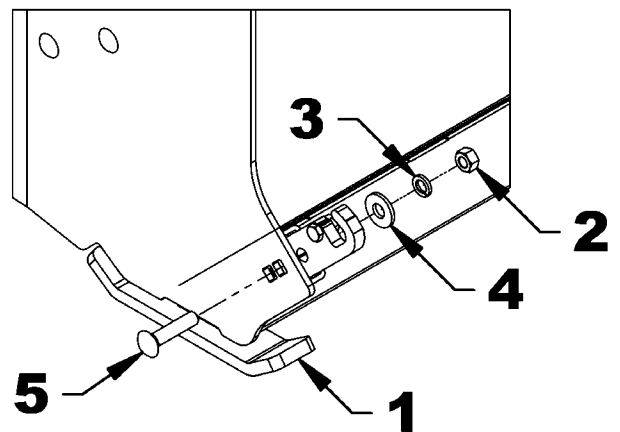

N°	PARTS SKID SHOE FIGURE	QTY
1	Skid shoe	1
2	Hex nut $\varnothing 3/8$ " NC	1
3	Lockwasher $\varnothing 3/8$ "	1
4	Flat washer $\varnothing 3/8$ "	1
5	Carriage bolt $\varnothing 3/8$ " NC x 1 3/4"	1

OPERATION

SNOW REMOVAL METHODS

When removing snow, do not use the snowblower as a dozer blade to push snow. Let the snowblower work its way through deep drifts. If the speed of your tractor is too fast, the snowblower may become overloaded and clog. For best results, raise the snowblower and remove a top layer of snow. A second pass with the snowblower will remove the remaining snow.

IMPORTANT: Use full RPM power when removing wet, sticky snow. Low RPM power will tend to clog the chute.

! WARNING: Do not use hands or feet to unclog chute. Do not attempt to clear clogged chute of snow while tractor engine is running. If the chute clogs, disengage the PTO according to owner's manual, shut off the tractor engine, remove the ignition key, wait for all movement to stop, and then clear the snow from the chute.

A definite pattern of operation is required to thoroughly clean the snow area. These patterns will avoid throwing snow in unwanted places as well as eliminating a need to perform a second pass with the snowblower.

PATTERN 1

DISCHARGE SNOW BOTH SIDES

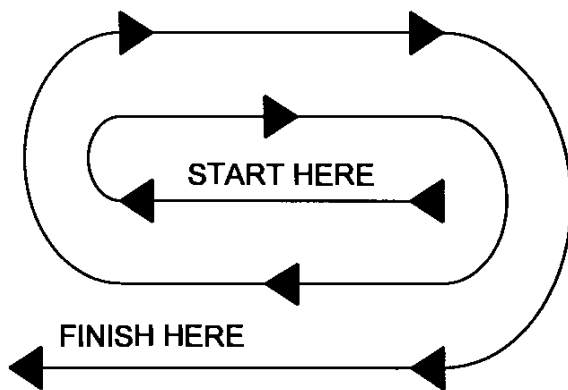

DISCHARGE SNOW BOTH SIDES

Where it is possible to throw the snow to the left and right (above), as on a long driveway, it is advantageous to start in the middle. Plow from one end to the other, throwing snow to both sides without changing the direction of the chute.

PATTERN 2

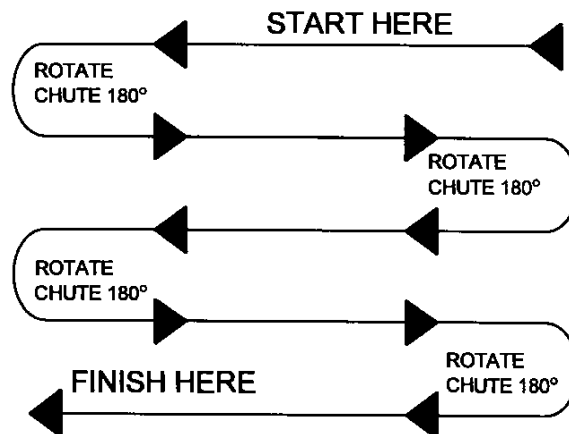

DISCHARGE SNOW THIS SIDE ONLY

If the snow can only be thrown to one side of the driveway or sidewalk (above), start on the opposite side. At the end of the first pass, rotate the discharge guide 180 degrees for the return pass. At the end of each succeeding pass, rotate the chute 180 degrees to maintain direction of throw in the same area.

MAINTENANCE

MAINTENANCE

ALWAYS USE GENUINE PARTS WHEN REPLACEMENT PARTS ARE REQUIRED

1. Keep the tractor and snowblower properly maintained.
2. Park the tractor/snowblower on level ground, place the transmission in neutral, set the parking brake, disengage the PTO, lower the snowblower to the ground, place all control levers in neutral, shut off the engine and remove the ignition key and allow the rotating parts to stop BEFORE making any snowblower adjustments.
3. To avoid injury, do not adjust, unblock the driving system, or service the snowblower with the tractor engine running.
4. Keep the tractor/snowblower clean. Snow, dirt or ice build-up can lead to malfunction or personal injury from thawing and refreezing in garage.
5. Always wear eye protection when cleaning or servicing the snowblower or subframe.
6. DO NOT service the tractor while the engine is running or hot, or if the unit is in motion. Always lower snowblower to the ground. If necessary to service snowblower in raised position, securely support with stands or suitable blocking before working underneath. Do not rely on hydraulically supported devices for your safety. They can settle suddenly, leak down, or be accidentally lowered
7. Always turn off the engine BEFORE unblocking equipment and making any repairs, adjustments, or inspection.
8. The manufacturer will not claim responsibility for fitment of unapproved parts and/or accessories and any damages because of their use.
9. Make sure all shields and guards are securely in place following all service, cleaning, or repair work.
10. Do not modify or alter this snowblower or any of its components or operating functions. If you have questions concerning modifications, consult with your dealer.
11. Do not operate a snowblower that is defective or has missing parts. Make sure that all recommended maintenance procedures are completed before operating the snowblower.
12. Check all controls regularly and adjust where necessary. Make sure that the brakes are evenly adjusted.
13. Periodically check all nuts and bolts for tightness, especially wheel hub and rim nuts.

MAINTENANCE

WARNING

To avoid serious injury or death:

- Before cleaning, adjusting or repairing the snowblower: bring the tractor to a complete stop, lower the equipment, switch off the engine and remove the ignition key.
- Never park the vehicle in a building where there are flames or sparks. Allow the engine to cool before storing the vehicle in an enclosed area.
- Let the snowblower run for a few minutes after blowing snow to prevent the auger and fan from freezing.
- Always remove the snowblower off the hitch if you need to work on the snowblower.

Gear Box and Reduction Box

When the gearbox or reduction box is opened, the seal must then be reestablished. To do this, apply a layer of silicone to the surface of the case before closing it. Allow the silicone to dry for a minimum of 24 hours before filling with oil.

Oil Level - Filling

To check the oil level: Remove the filler plug, if the oil does not reach the level of the plug, fill until the oil flows through the hole in the oil level plug. Put the two plugs back in place.

Oil change

Change the oil in the gearbox and reduction box every 150 hours or every 3 years if the number of hours has not been reached.

1. Remove the filler cap.
2. Remove the oil drain plug and allow the oil to drain until only a few fine drops escape.
3. Replace the drain plug and remove the oil level plug. Fill the reduction box/gearbox with SAE 80W90 oil, AGMA 5EP extreme pressure oil, or equivalent, to the oil level plug and replace the plug. Replace the filler cap.

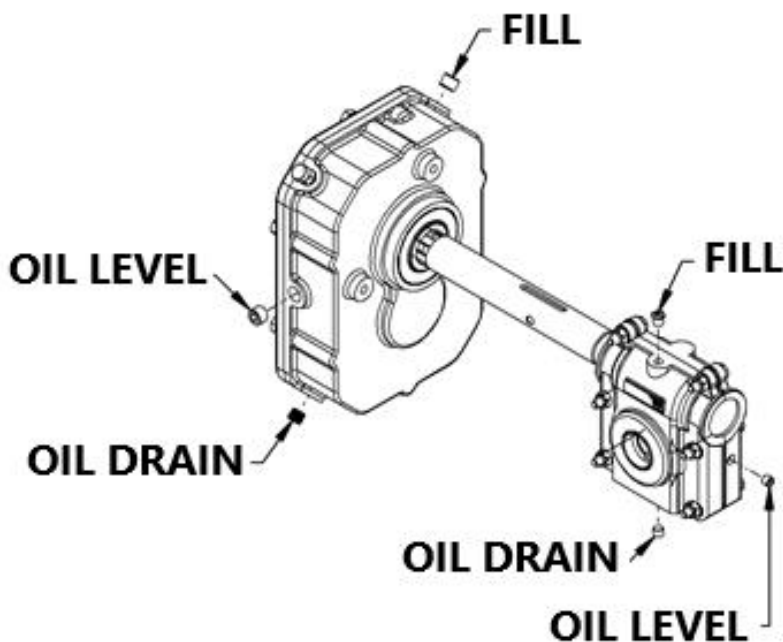

MAINTENANCE

Shear Bolts

1. Always use a grade 2 shear bolt (669596) on the fan (item 1) and special grade 5 grooved shear bolts (657295) on the auger sections (item 2).
2. Check the tightness of the shear bolts at regular intervals to make sure the snowblower is safe.

Repositioning of the Augers

After a shear bolt breaks on one of the augers, be sure to reposition the screws as shown in the figure below, so that they are 180° away from each other.

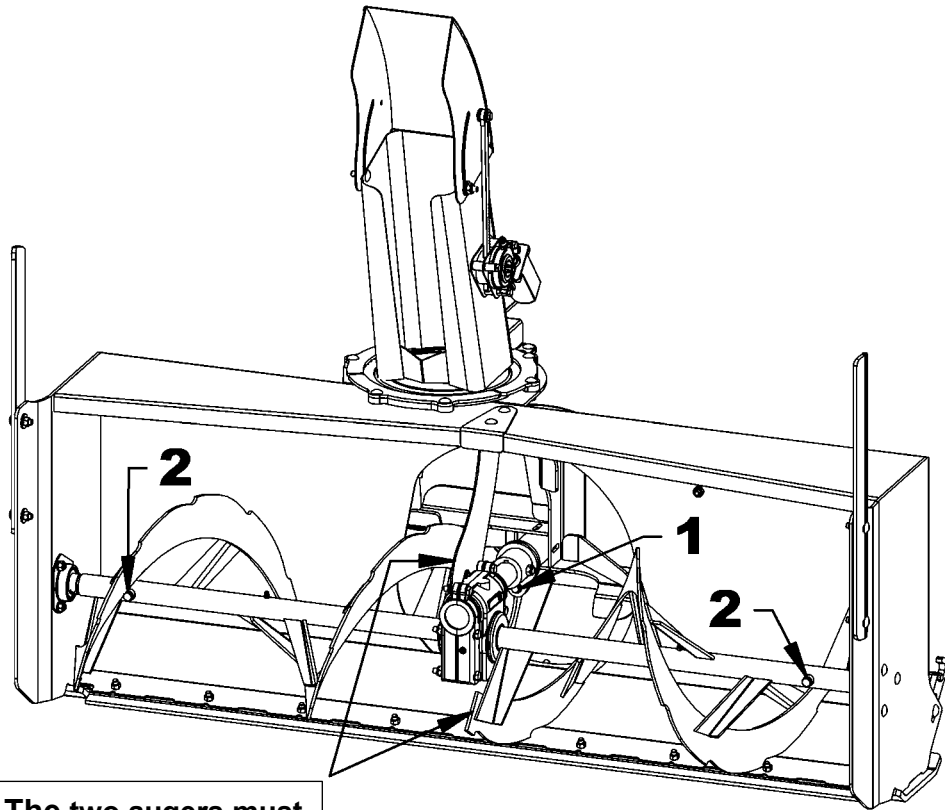

IMPORTANT: The two augers must be opposite.

Maintenance Schedule

DESCRIPTION	INTERVAL	REQUIRED MAINTENANCE
Hardware	After the first 8 hours of operation	Tighten all nuts and bolts according to the Torque Specification Table.
	40 hours of operation	
Connection Points	Before each equipment connection	Visual inspection of the driveline, hydraulic/electrical connectors and hitch connection points. Clean if necessary.
Connection system	After the first 8 hours of operation	Visual inspection. Retighten, repair or replace if necessary.
	40 hours of operation	

MAINTENANCE

PROBLEM: HYDRAULIC CHUTE ROTATION IS SLOW OR DOES NOT TURN

When activating the chute rotation, it turns very slowly or not at all.

⚠ WARNING To avoid serious personal injury, always wear safety glasses while doing the instructions below.

SOLUTION:

1. Check if the tractor valve works well. Test it by plugging another piece of equipment to the valve. If it does not work well, refer to the appropriate operator's manual.
2. Check if the chute alone turns well by removing the bolt (item 6) and the gear (item 5) of the hydraulic motor (item 3) then manually rotate the chute in both directions. If it does not turn well, correct the problem by checking for excess wear or debris stuck between the components.
3. If the chute turns well manually, but it turns well in one direction with the hydraulic motor, check if there are residues in the hydraulic circuit by removing the bolt, lock washer, flat washer (item 6) and the motor gear (item 5) (item 3) then activate rotation in the direction in which the motor runs well for about 1 minute to evacuate the residues.
4. Rotate the chute in the direction it did not turn to see if the problem is corrected. If the problem persists or if the chute does not turn well in both directions, release the pressure from the system: turn the ignition key to ON without starting the engine, activate the float mode with the control handle and turn the ignition key to OFF.
5. Disconnect the hoses from the engine, remove the 2 adapters (item 4) and carefully inspect the orifices of the 2 engine flow limiters (items 3a-3b). Remove residue, if any, with compressed air. If no residue is found, disconnect the hoses and clean with compressed air.

IMPORTANT: When disconnecting the connectors, be sure to always install the protective plugs and caps on the hydraulic connectors of the tractor hoses and valve to prevent contamination of the hydraulic circuit and clogging of the orifices of the flow restrictors of the tractor hydraulic motor.

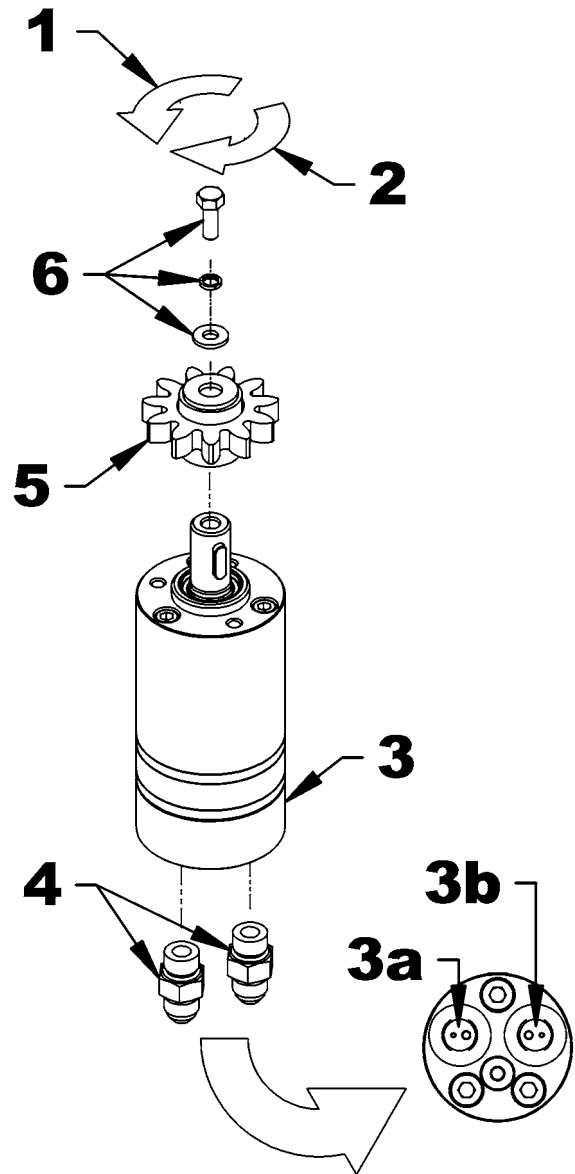

MAINTENANCE

LUBRICATION

Use a grease gun and lubricate as follows:

DESCRIPTION	INTERVAL	REQUIRED LUBRICATION
Gearbox & Reduction box	Monthly	Check oil level. If needed, add extreme pressure oil, SAE 80W90 gear oil or equivalent.
Auger and Driveline	24 hours of operation or at least once a year	Inject grease into the grease fitting of each auger section. Use Shell Gadus S5 V100 grease or equivalent
Rack	20 hours of operation and at the end of the season	Apply a light coat of grease to the teeth of the rack and then run a few deflection cycles. Use Shell Gadus S5 V100 grease or equivalent
Pivot bushing	20 hours of operation and at the end of the season	Lubricate with a heavy grade chainsaw oil.

IMPORTANT: Perform all the maintenance section without taking into account the hours given in the following cases:

- At least once a year if the snowblower is used less than 20 hours annually.
- After each wash.
- After each storage period.

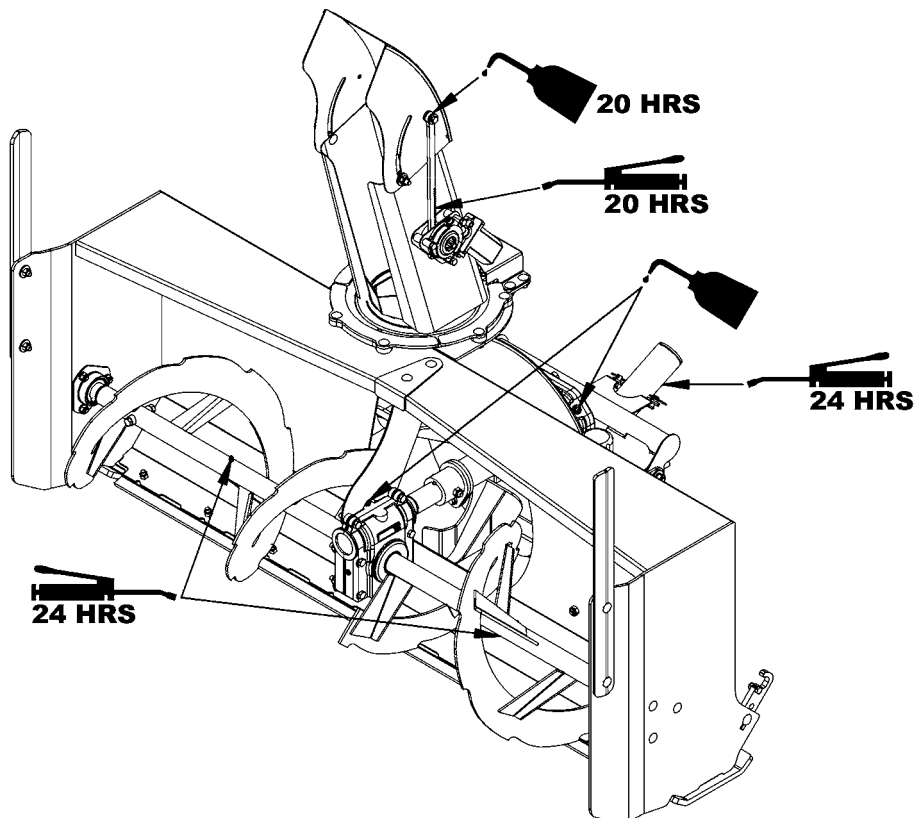

TROUBLESHOOTING

PROBLEM	CORRECTIVE MEASURES
1. Auger and fan not turning	<ul style="list-style-type: none"> • Check if an object is blocking the auger or fan • Check that PTO is engaged • Check that the drive system is in the engaged position • Check if chain is broken • Check if shearbolts are broken and replace if necessary • Gearbox lacking oil and is seized. Replace gearbox.
2. Snow is not being ejected from the chute	<ul style="list-style-type: none"> • Check if the fan is turning, refer to problem # 1 • Check if the snow output is obstructed, unclog with a 36" stick
3. Snowblower clogs up easily	<ul style="list-style-type: none"> • Engine is not at full RPM • Check that the chute is not obstructed • Reduce travel speed
4. Snow doesn't enter the snowblower properly	<ul style="list-style-type: none"> • Engine is not at full RPM • Check if shearbolts are broken and replace if necessary • Check auger positions. (refer to section Operation)
5. Snow is not thrown very far	<ul style="list-style-type: none"> • Engine is not at full RPM • Reduce travel speed • Check that the chute is not obstructed
6. Snowblower will not connect to the hitch	<ul style="list-style-type: none"> • Check that the connection system is not obstructed • Make sure that the pins of the snowblower hitch are removed. • Make sure that the snowblower driveline is on its support.

STORAGE

STORAGE

(Figures A-B)

Before storing the snowblower, certain precautions should be taken to protect it from deterioration.

1. Clean the snowblower and hitches thoroughly.
2. Make all the necessary repairs.
3. Replace any safety decals that are damaged, lost, or no longer legible. If a part that needs to be replaced requires a safety decal, obtain a new one from your dealer and place it in the same location as the original part.
4. Paint any parts that are worn or chipped.
5. Lubricate the snowblower as instructed in the "Lubrication" section.
6. When the snowblower is dry, oil the moving parts. Liberally oil all surfaces to prevent rusting.
7. **Figure A:** Insert each of the $\varnothing 1" \times 3 \frac{7}{8}"$ pins (item 1) in the hole (item 2) on each side of the snowblower frame.
8. **Figure A:** Insert each of the $\varnothing 1/4"$ round locking pins (item 3) in the hole (item 4) on each side of the snowblower frame.
9. **Figure A:** Remove the male driveline (item 5) from the drive system on top of the 4-pt hitch.
10. **Figure B:** Wind the hydraulic hoses and the electric harness around the chute.
11. Store in a dry place.

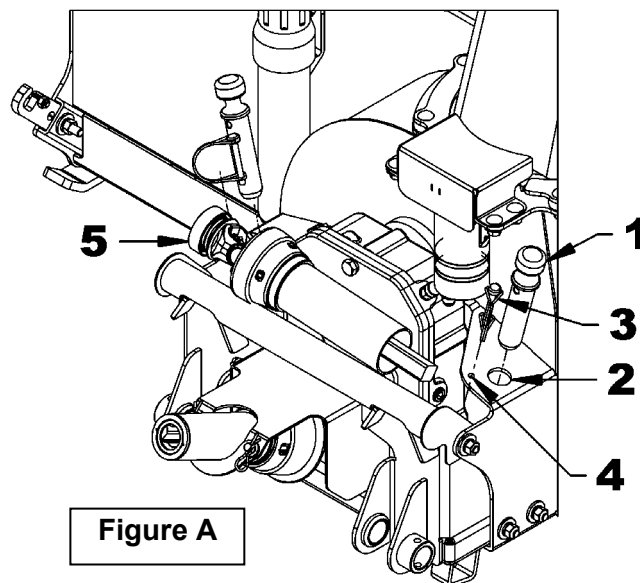

Figure A

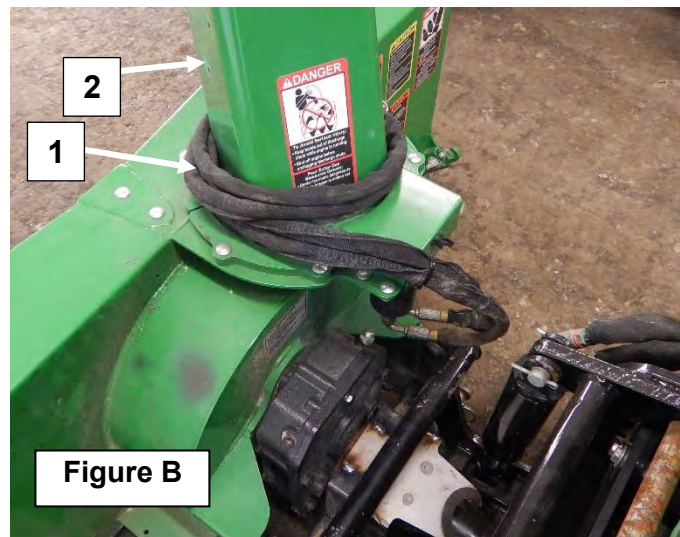

Figure B

PARTS

54" SNOWBLOWER - REAR			
REF.	DESCRIPTION	QTY	PART #
1	Housing	1	671827
2	Skid shoe	2	671839
3	Cutting edge	1	671830
4	4 pt hitch - snowblower	1	671849
5	Driveline support	1	671850
6	Drift cutter	2	671848
7	Pin \varnothing 1" x 3 7/8", PTD	2	671814
8	Reduction box- ratio 2.5 @ 1	1	4500184 or 4500228
9	Female driveline	1	4700044
10	Hex bolt \varnothing 1/4"NC x 3/4" Gr.5 PTD	2	0100003
11	Nylon insert locknut \varnothing 1/4"NC PTD	3	1000003
12	Carriage bolt \varnothing 3/8"NC x 1 3/4" PTD	2	0300011
13	Flat washer \varnothing 3/8" PTD	14	1400004
14	Lockwasher \varnothing 3/8" PTD	8	1200004
15	Hex nut \varnothing 3/8"NC PTD	8	0900003
16	Carriage bolt \varnothing 5/16"NC x 1" PTD	9	0300003
17	Stover nut \varnothing 5/16"NC PTD	13	1100002
18	Hex bolt \varnothing 3/8"NC x 2 1/2" Gr.5 PTD	4	0100044
19	Hex bolt \varnothing 3/8"NC x 1 1/4" Gr.5 PTD	2	0100039
20	Manual holder	1	4200030
21	Hex bolt \varnothing 5/16"NC x \varnothing 3/4" Gr.5 PTD	2	0100018
22	Nylon insert locknut \varnothing 5/16"NC PTD	2	1000005
23	Round wire lock pin \varnothing 1/4" x 1 3/4"	2	1900006
24	Hairpin 2.5mm x 40mm	2	1800001
25	Carriage bolt \varnothing 5/16"NC x 1 1/4" PTD	4	0300004
26	Hex bolt M10 x 1.50 x 25mm Gr. 8.8 PTD	3	0200014
27	Hex bolt \varnothing 1/4"NC x 2" Gr.5 PTD	1	0100010
28	Allen socket set screw \varnothing 3/8"NC x 1/4" Gr.5	1	0500030
29	Key 1/4" x 1/4" x 1" Lg	1	655379
30	Flat washer \varnothing 5/16" (3/8" int) PTD	4	1400003

PARTS

54" SNOWBLOWER - REAR

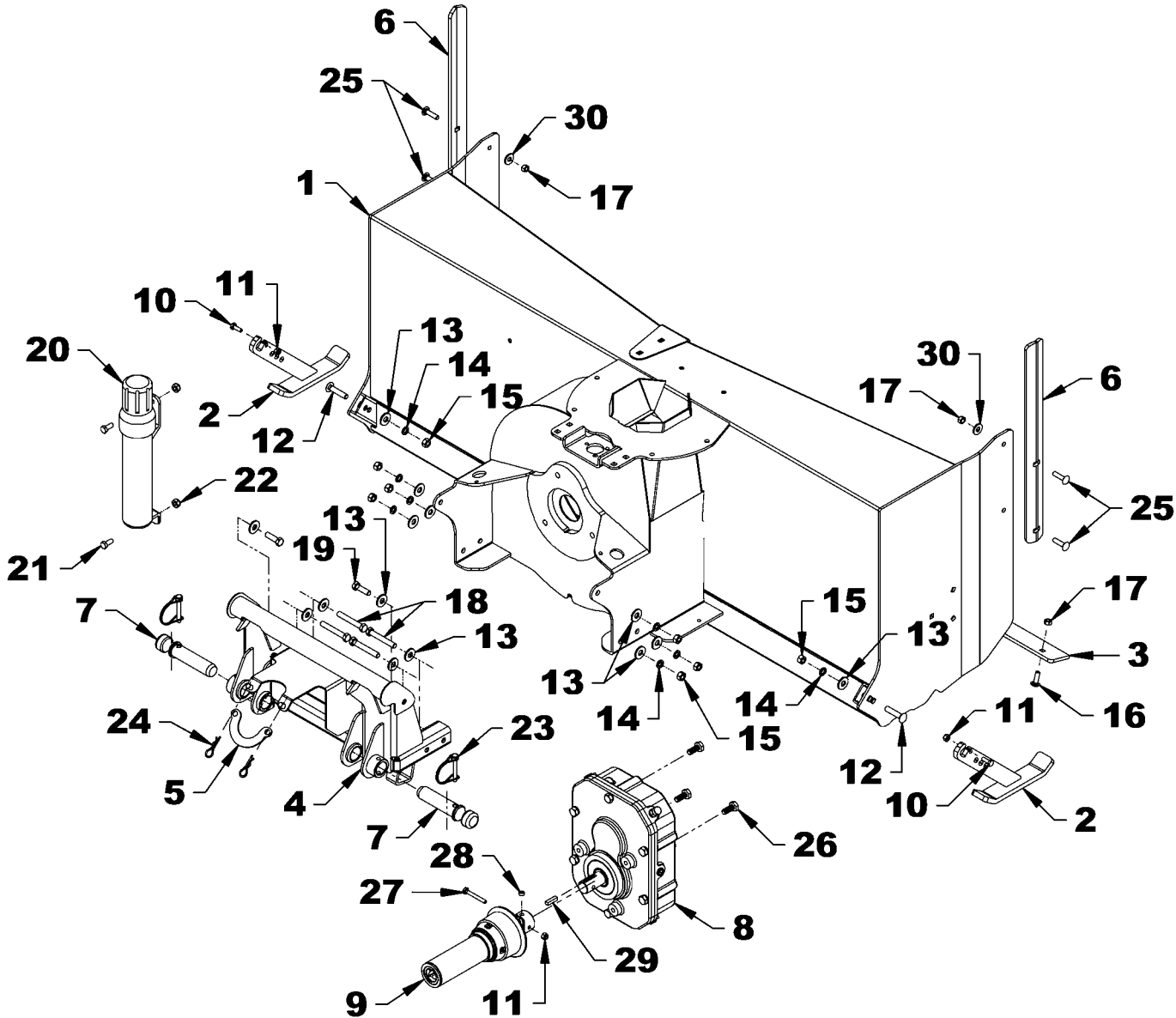

PARTS

54" SNOWBLOWER -FRONT			
REF.	DESCRIPTION	QTY	PART#
1	Shear plate	1	669241
2	Fan ø16" CCW. - 4 blades	1	671838
3	Right auger	1	669239
4	Left auger	1	669240
5	Output driveline ø1" x 53"	1	669243
6	Worm gear box support	1	671840
7	Key 1/4" x ø7/8" HALF MOON #807	1	655967
8	Motor gear	1	665688
9	Gear shield	1	671847
10	CCW worm gear box	1	4500183
11	Hex bolt ø5/16" NC x 2 1/2" Lg. GR. 5, PTD	1	0100026
12	Nylon insert locknut ø5/16"NC PTD	1	1000005
13	Shear bolt ø1/4"NC x 1 1/4" Gr.2 + nut and lockwasher	1	669596
14	Shear bolt ø5/16"NC x 2 1/4" Gr.5 + nut and lockwasher	2	657295
15	Round end key ø1/4" x 1/4" x 2" Lg.	1	658188
16	Grease fitting ø1/4" NF	2	654106
17	Carriage bolt ø5/16"NC x 3/4" PTD	12	0300002
18	Lockwasher ø5/16" PTD	12	1200003
19	Hex nut ø5/16"NC PTD	12	0900002
20	Hose protector 10" Lg	2	669154
21	Flange bearing ø1" with set screw	2	4300145
22	Rotation bushing 1.378" x 1.627 x 2" Lg	2	4300067
23	Flat washer ø5/16" PTD	4	1400003
24	Hex bolt M6 x 1.00 x 16 mm Gr.8.8 PTD	4	0200096
25	Lockwasher ø1/4" PTD	1	1200002
26	Flat washer ø1/4" (5/16" int.) PTD	1	1400002
27	Flat washer 6mm PTD	3	1200013
28	Flat washer #12 (1/4" int) PTD	3	1400016
29	32cc hydraulic motor with restrictor	1	3910117
-	Seal kit and Instruction sheet	1	3910015
30	Round end key 5mm x 5mm x 16mm	1	3900124
31	Adaptor ø9/16" JIC M x ø9/16" ORB M	2	661544
32	Hose ø1/4" x 66", 9/16"JIC SWF 90° x 1/4"NPT M	2	3700306
33	90° Elbow ø1/4"NPT M x ø1/4"NPT SWF	2	655211
34	Male quick coupler ø1/4"NPT	2	657094
35	Dust cap ø1/4"NPT	2	2600052
36	Identification ring YELLOW	2	658206
37	Identification ring GREEN	2	658209

PARTS

54" SNOWBLOWER -FRONT

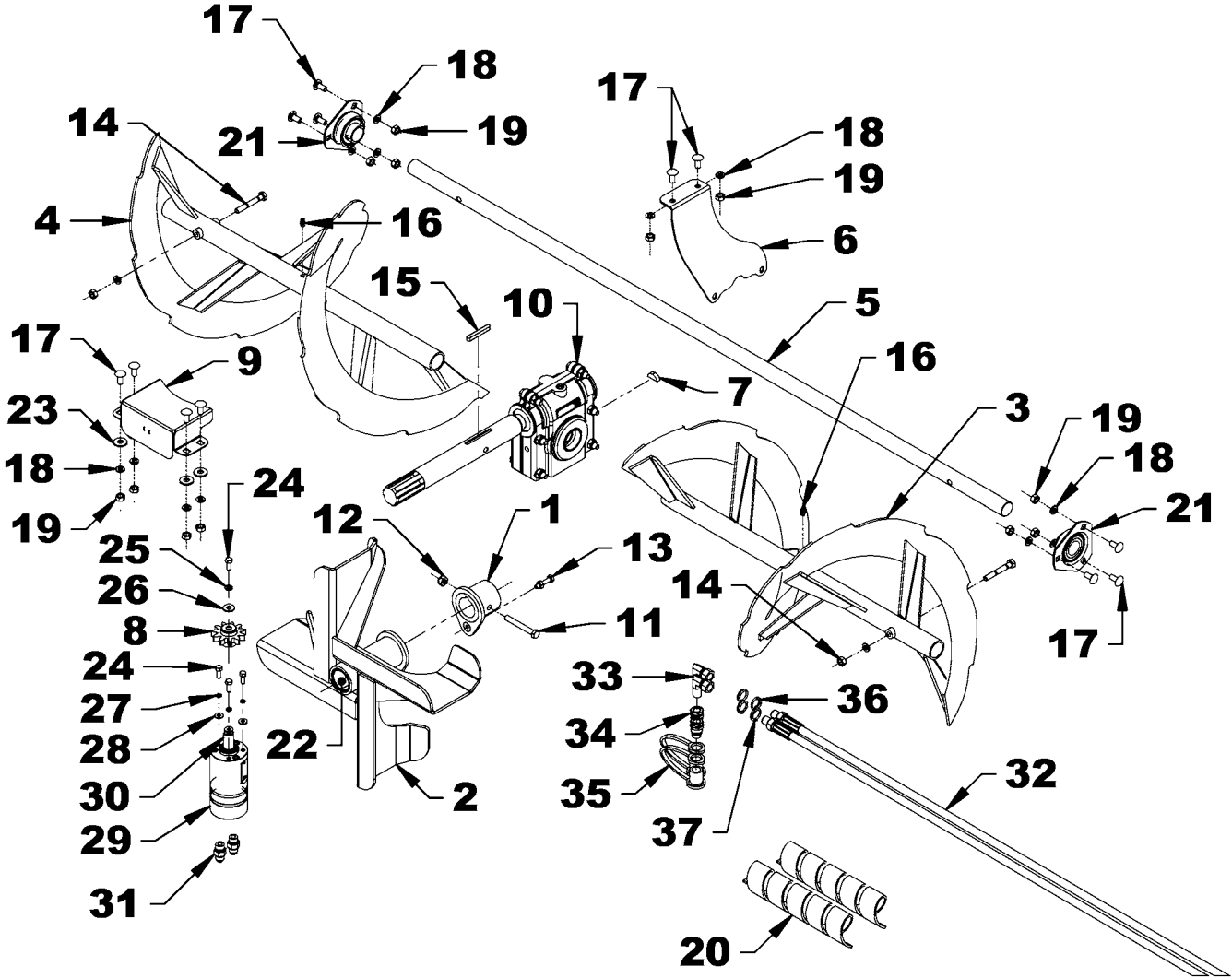

PARTS

CHUTE AND ELECTRIC DEFLECTOR

REF.	DESCRIPTION	QTY	PART#
1	Assembled chute with English decals	1	671842
	WARNING: To avoid serious injury: we recommend purchasing the bilingual safety decals with the chute (see decals on page 10)		
2	Retaining plate - long	1	671845
3	Retaining plate - short	2	671844
4	Spacer	3	671846
5	Switch box	1	667557
6	Switchbox clamp	1	667558
7	Guide plate	2	670154
8	Spacer $\varnothing 3/8"$ x .721 PTD	3	670156
9	Pivot bushing $\varnothing 3/8"$ x 19/32" PTD	1	670157
10	Rack PTD	1	670153
11	Nylon rack guide	1	670155
12	Electric motor	1	662455
13	Hex bolt $\varnothing 1/4"$ NC x 2" Gr.5 PTD	3	0100010
14	Hex bolt $\varnothing 1/4"$ NC x 1 1/4" Gr.5 PTD	1	0100005
15	Nylon insert locknut $\varnothing 1/4"$ NC PTD	4	1000003
16	Flat washer $\varnothing 1/4"$ PTD	1	1400002
17	Nylon flat washer $\varnothing 7/16"$	5	658468
18	Carriage bolt $\varnothing 5/16"$ NC x 1" PTD	2	0300003
19	Nylon insert locknut $\varnothing 5/16"$ NC PTD	2	1000005
20	Flat washer $\varnothing 5/16"$ PTD	8	1400003
21	Lockwasher $\varnothing 5/16"$ PTD	6	1200003
22	Hex nut $\varnothing 5/16"$ NC PTD	6	0900002
23	Carriage bolt $\varnothing 5/16"$ NC x 1 1/4" PTD	6	0300004
24	4-blade switch	1	663383
25	Rubber cap for switch	1	658666
26	Chute deflector decal	1	2500788
27	Hex bolt $\varnothing 1/4"$ NC x 1" Gr.5 PTD	2	0100004
28	Lockwasher $\varnothing 1/4"$ PTD	2	1200002
29	12V Relay	1	4000028
30	Quadrex Drive Round Head Machine Screw 8-32 x $\varnothing 3/4"$, PTD	1	2700011
31	Nylon insert locknut 8-32 PTD	1	1000026
32	Flat washer #8 (3/16" int) PTD	1	1400001
33	Tap connector	1	656665
34	Cap with three electrical components	1	4000178
35	Electric harness tractor side - deflector	1	4000203
36	Electrical harness with fuse - deflector	1	4000173
-	- Fuse ATO 20 amp.	1	663327
37	Electric harness snowblower side - deflector	1	4000174
38	Rotation bushing	1	657338
39	Nylon flat washer $\varnothing 11/32"$	2	658467
40	Spacer 16ga PTD	3	672857

PARTS

CHUTE AND ELECTRIC DEFLECTOR

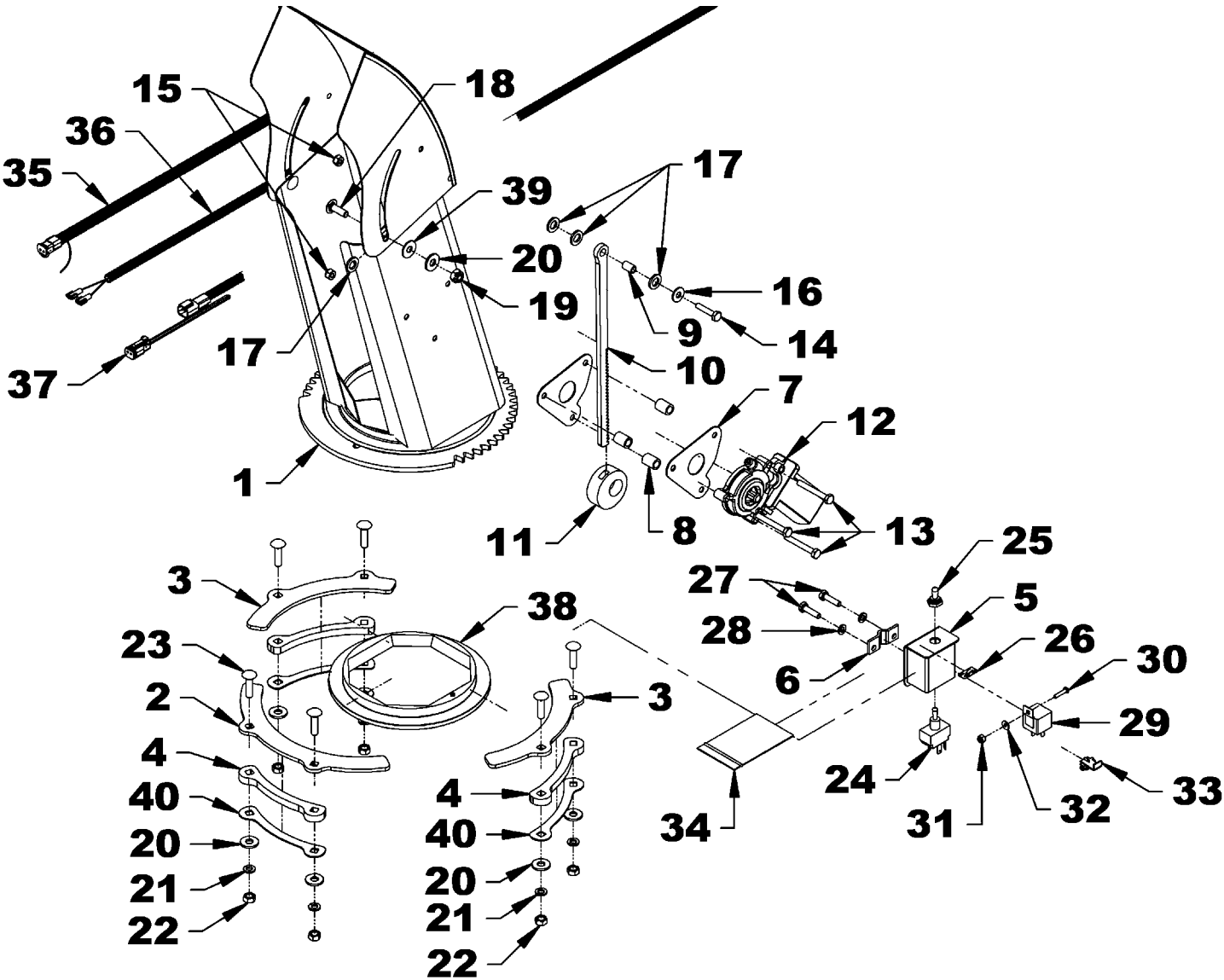

PARTS

REDUCTION BOX - 4500184 AND 4500228

REF	DESCRIPTION	QTY	PART#
1	Hex bolt M10 x 1.50 x 30mm Gr. 8.8	6	0200016
2	Lockwasher 10mm	6	1200018
3	Ball bearing	1	659843
4	Ball bearing	1	659838
5	Snap ring	1	656642
6	Seal	1	659839
7	Tapered bearing	1	4300069
8	Tapered bearing	1	656647
9	Snap ring	1	656654
10	Seal	1	659845
11	Plug \varnothing 1/4"NPT	2	663570
12	Plug \varnothing 3/8"NPT	2	655259
13	Vent	1	656662
14	Spacer kit	1	4500190

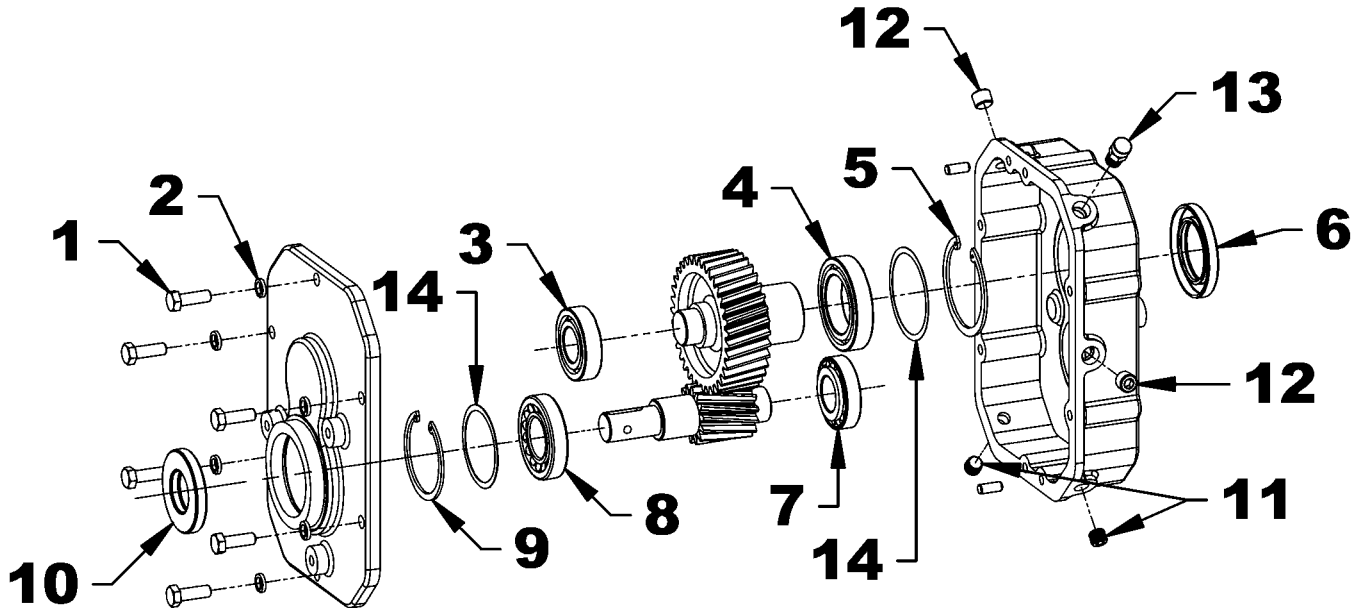

PARTS

WORM GEAR BOX- 4500183

REF.	DESCRIPTION	QTY	PART#
1	2 Part casing	1	4500021
2	Breather $\varnothing 1/8"$ NPT, 5 PSI, PTD	1	654927
3	Plug $\varnothing 1/8"$ NPT, PTD	2	656090
4	Tapered roller bearing	1	4300125
5	Driveline 16 3/8" Lg	1	4500191
6	Bearing	2	661147
7	Tapered roller bearing	2	663234
8	Hex bolt $\varnothing 5/16"$ NC x 1 1/2" Lg. Gr.5 PTD	2	0100021
9	Hex bolt $\varnothing 5/16"$ NC x 2 3/4" Lg. Gr.5 PTD	4	0100027
10	Seal kit	1	665775
11	Spring pin $\varnothing 5/16"$ x 1 1/4" Lg.	1	663243
12	Cap	1	661150
13	Spacer	1	4500124
14	Pin $\varnothing 3/16"$ x 1/2" Lg.	2	663245
15	Nylon insert locknut $\varnothing 5/16"$ NC, PTD	6	1000005

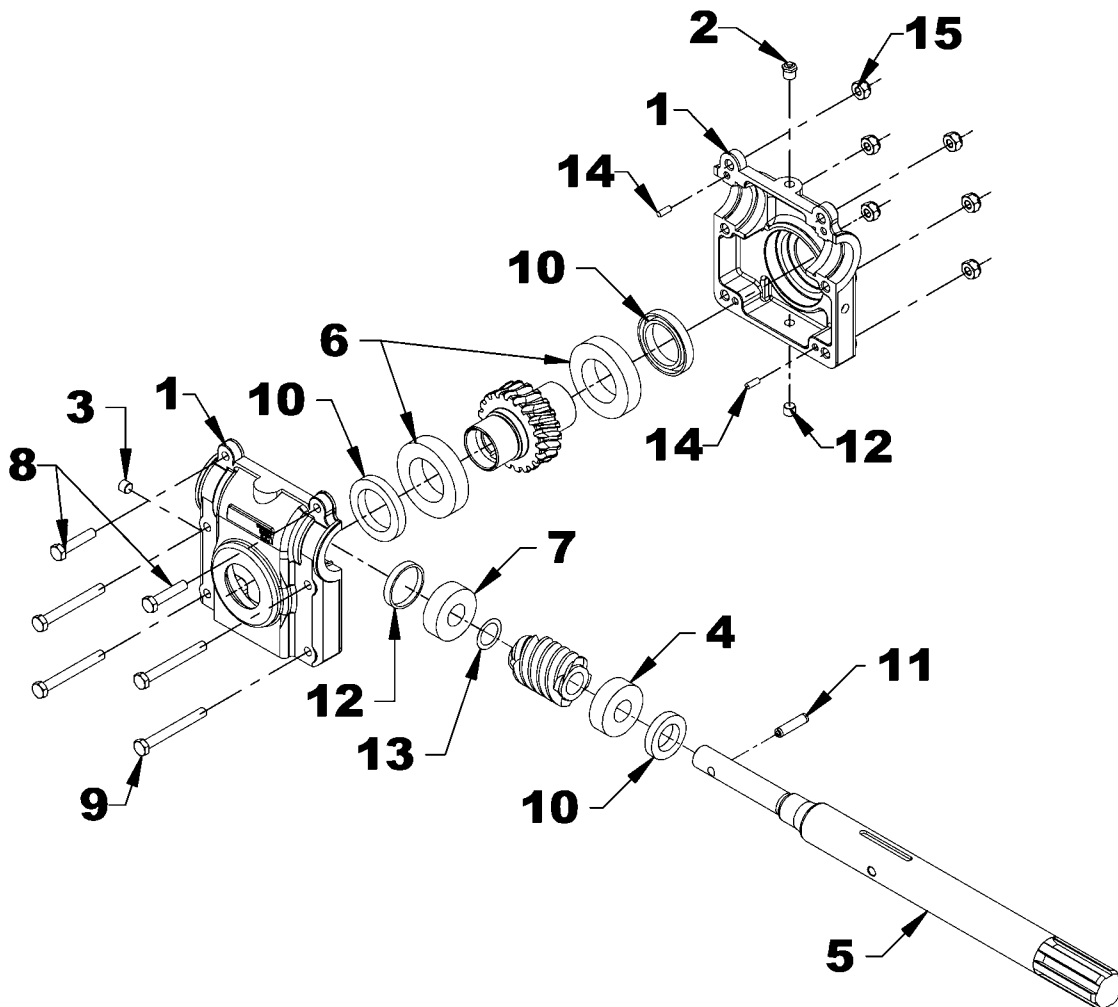

PARTS

FEAMALE DRIVELINE - 4700044

REF.	QTY	DESCRIPTION	PART #
1	1	Driveline female half ass'y	4700044
2	1	Inner shield	658511
3	1	Nylon repair kit	661555
4	1	Yoke & female shaft ass'y	4700071
5	1	Journal cross	4700066
6	1	Yoke 1" dia.hole.	4700072

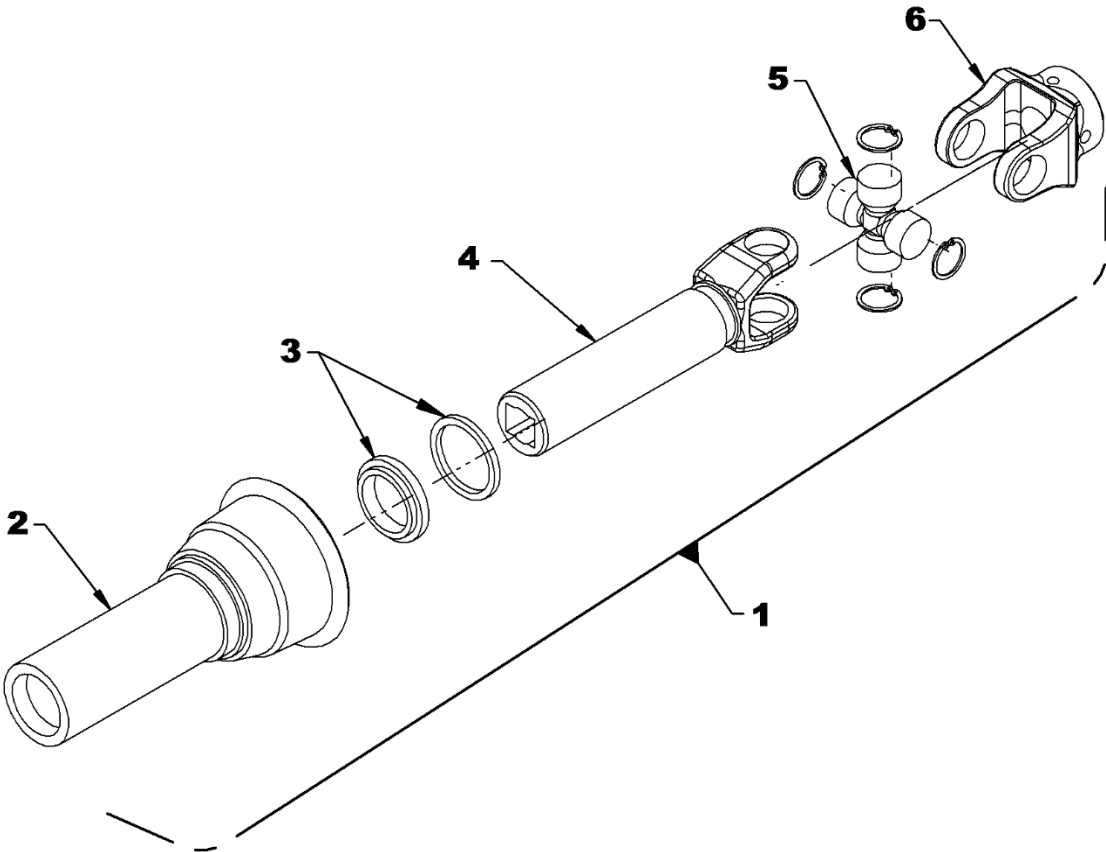

WARRANTY



RADTECH warrants to the original purchaser that the equipment is free from all defects in material and workmanship. According to this warranty, RADTECH's liability is limited to the repair or replacement of any component or part, other than parts that deteriorate with normal use, deemed defective, for one year following the original date of purchase. (unless otherwise stated). The warranty for commercial use and for rental agencies is limited to ninety (90) days from the date of purchase.

In any case, RADTECH will not be held responsible for direct or indirect damage caused to/or suffered by the buyer / user.

All components that are not manufactured by RADTECH (such as motors, cylinders, hydraulic components, tires, etc.) are covered by the warranty of the original manufacturer in collaboration with RADTECH

Under the terms of this warranty, RADTECH's responsibility is limited to repairing or replacing, free of charge to the original purchaser, any part which, according to RADTECH, shows signs of defect, provided that the distributor returns the part, postage paid, within thirty (30) days of the mechanical failure.

This warranty should not be interpreted in such a way as to hold RADTECH responsible for injuries, prejudices, injuries to a person or for damages to property of any kind. This warranty does not cover losses incurred by delays or, expenses or losses incurred for labor, replacement machinery, rental or any other reason.

With the exception of what is described above, RADTECH will not be held responsible for its equipment or for direct or indirect damage. RADTECH makes no other warranty, express or implied, more specifically, RADTECH rejects any implied warranty of merchantability and suitability for a specific purpose. **Some states and provinces do not recognize limitations on implied warranties and/or do not allow the exclusion of direct or indirect damages; therefore, the limits described in this warranty may be invalid.**

This warranty is subject to existing conditions of supply which may directly affect our ability to obtain material or manufacture replacement parts. RADTECH reserves the right to make changes to specifications at any time, without being liable to owners of previously sold equipment.

No one is authorized to modify or add to this warranty, exclusions, limitations or reservations.

2835 Chemin de l'Aéroport, Thetford Mines (Quebec) G6G 5R7
T +1 418 338-4499 - F +1 418 338-2522
info@radtech.ca
radtech.ca







TORQUE SPECIFICATION TABLE

GENERAL SPECIFICATION TABLE

USE THE FOLLOWING TORQUES WHEN SPECIAL TORQUES ARE NOT GIVEN

Note: These values apply to fasteners as received from supplier dry, or when lubricated with normal engine oil. They do not apply if special graphited or moly sidulphide greases or other extreme pressure lubricants are used. These values apply to dry conditions; under lubricated conditions reduce by 25% the torques in this table.

BOLT HEAD IDENTIFICATION

INCHES Bolt Size	 Grade 2		 Grade 5		 Grade 8		METRIC Bolt Size	 Class 5.8		 Class 8.8		 Class 10.9	
	in-tpi ¹	N-m ²	lbs-ft ³	N-m	lbs-ft	N-m		lbs-ft	mm x pitch ⁴	N-m	lbs-ft	N-m	lbs-ft
1/4" – 20NC	7.4	5.6	11	8	16	12	M 5 X 0.8	4	3	6	5	9	7
1/4" – 28NF	8.5	6	13	10	18	14	M 6 X 1	7	5	11	8	15	11
5/16" – 18NC	15	11	24	17	33	25	M 8 X 1.25	17	12	26	19	36	27
5/16" – 24NF	17	13	26	19	37	27	M 8 X 1	18	13	28	21	39	29
3/8" – 16NC	27	20	42	31	59	44	M10 X 1.5	33	24	52	39	72	53
3/8" – 24NF	31	22	47	35	67	49	M10 X 0.75	39	29	61	45	85	62
7/16" – 14NC	43	32	67	49	95	70	M12 X 1.75	58	42	91	67	125	93
7/16" – 20NF	49	36	75	55	105	78	M12 X 1.5	60	44	95	70	130	97
1/2" – 13NC	66	49	105	76	145	105	M12 X 1	90	66	105	77	145	105
1/2" – 20NF	75	55	115	85	165	120	M14 X 2	92	68	145	105	200	150
9/16" – 12NC	95	70	150	110	210	155	M14 X 1.5	99	73	155	115	215	160
9/16" – 18NF	105	79	165	120	235	170	M16 X 2	145	105	225	165	315	230
5/8" – 11NC	130	97	205	150	285	210	M16 X 1.5	155	115	240	180	335	245
5/8" – 18NF	150	110	230	170	325	240	M18 X 2.5	195	145	310	230	405	300
3/4" – 10NC	235	170	360	265	510	375	M18 X 1.5	220	165	350	260	485	355
3/4" – 16NF	260	190	405	295	570	420	M20 X 2.5	280	205	440	325	610	450
7/8" – 9NC	225	165	585	430	820	605	M20 X 1.5	310	230	650	480	900	665
7/8" – 14NF	250	185	640	475	905	670	M24 X 3	480	355	760	560	1050	780
1" – 8NC	340	250	875	645	1230	910	M24 X 2	525	390	830	610	1150	845
1" – 12NF	370	275	955	705	1350	995	M30 X 3.5	960	705	1510	1120	2100	1550
1 1/8" – 7NC	480	355	1080	795	1750	1290	M30 X 2	1060	785	1680	1240	2320	1710
1 1/8" – 12NF	540	395	1210	890	1960	1440	M36 X 3.5	1730	1270	2650	1950	3660	2700
1 1/4" – 7NC	680	500	1520	1120	2460	1820	M36 X 2	1880	1380	2960	2190	4100	3220
1 1/4" – 12NF	750	555	1680	1240	2730	2010							
1 3/8" – 6NC	890	655	1990	1470	3230	2380							
1 3/8" – 12NF	1010	745	2270	1670	3680	2710							
1 1/2" – 6NC	1180	870	2640	1950	4290	3160							
1 1/2" – 12NF	1330	980	2970	2190	4820	3560							

- ¹ in-tpi = nominal thread diameter in inches-threads per inch
- ² N-m = newton-meters
- ³ lbs-ft= pounds-foot
- ⁴ mm x pitch = nominal thread diameter in millimeters x thread Pitch

*Torque tolerance +0%, -15% of torquing values. Unless otherwise specified use torque values listed above

ADAPTER INSTALLATION PROCESS

NPT THREAD IDENTIFICATION & TORQUE

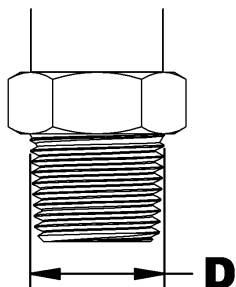

D		Identification of adapter	Number of turns to do after manual tightening
in	mm		
0.375	9.5	1/8 NPT	2.0 - 3.0
0.500	12.5	1/4 NPT	2.0 - 3.0
0.625	15.9	3/8 NPT	2.0 - 3.0
0.780	19.8	1/2 NPT	2.0 - 3.0
0.988	25.1	3/4 NPT	2.0 - 3.0
1.236	31.4	1 NPT	1.5 - 2.5
1.583	40.2	1 1/4 NPT	1.5 - 2.5
1.823	46.3	1 1/2 NPT	1.5 - 2.5

RECOMMENDED ASSEMBLY

The method used to assemble fittings with NPT threads is done in two stages. First firmly tighten by hand then tighten once again according to the number of turns listed in the above table. The following steps are recommended to minimize the risks of leaks and/or damages to the parts.

STEP 1: Inspect threads and tapping to make sure they are clean.

STEP 2: Measure the diameter (D) of the adapter and take note of the size taken.

STEP 3: Apply a sealant/lubricant product to the NPT threads (teflon covered threads are preferable to other lubricating products). If PTFE tape (teflon) is used, make between 1.5 or 2 turns clockwise, when viewed by the fitting end, keeping free the two first threads.

CAUTION: More than 2 turns can cause distortion or cracks in the orifice.

STEP 4: Tighten the fitting manually.

STEP 5: Screw the fitting the number of turns listed on the above table making sure that in the case of an elbow fitting the end is aligned to the desired position to connect the tube or hose. **Never unscrew a fitting to obtain the proper alignment.**

STEP 6: If a leak is detected after having followed the preceding instructions, check that the threads are not damaged and the number of seated threads is fulfilled (see details in next paragraph).

If the threads are damaged, replace the fitting. If the tapping is damaged, retap if possible or replace the part.

Usually, the number of threads seated is between 3.5 and 6. If the range is different it would indicate that the fitting was tightened too much or not enough or that the tightening was not within thread tolerances. If the fitting is not tight enough, tighten but never more than one turn. If it's too tight, inspect the threading and tapping and replace the section that has threads that are not within tolerances.

ADAPTER INSTALLATION PROCESS

JIC THREAD IDENTIFICATION & TORQUE

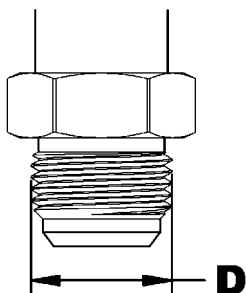

D		Identification of adapter	TORQUE	
in	mm		lbs-ft	N-m
-	-	5/16 JIC	6-7	8-10
-	-	3/8 JIC	6-9	8-12
0.433	11	7/16 JIC	9-12	12-16
0.496	12.6	1/2 JIC	14-15	19-21
0.559	14.2	9/16 JIC	18-20	24-27
0.740	18.8	3/4 JIC	27-39	37-53
0.870	22.1	7/8 JIC	36-63	49-85
1.055	26.8	1 1/16 JIC	65-88	88-119
1.185	30.1	1 3/16 JIC	75-103	102-140
1.307	33.2	1 5/16 JIC	85-113	115-153
1.618	41.1	1 5/8 JIC	115-133	156-180
1.870	47.5	1 7/8 JIC	125-167	169-226
2.492	63.3	2 1/2 JIC	190-258	258-350

JIC flare fittings seal with metal to metal contact between the flared nose of the fitting and the flared tube face in the female connection.

The minimum torque values listed are to provide a benchmark that give optimum results for leak free connections. Actual torque values should be based on individual application.

NOTE: Do not apply thread sealant (teflon tape) on the JIC threads.

Leaks can result from vibration, thermal cycling and from loads being supported by the connection (i.e. using the fitting in the connection to support mechanical loads).

IMPORTANT: Use the lowest torque value from the chart when wet torquing.

RECOMMENDED ASSEMBLY

STEP 1: Inspect for possible contamination or damage from shipping or handling. Sealing surface should be smooth.

STEP 2: Lubricate the threads and the entire surface of the cone with hydraulic fluid or a light lubricant.

STEP 3: Align mating components for hand connection and turn flare nut until sealing surfaces make full contact.

STEP 4: Torque nut to the values shown in the above table.

STEP 5: When torquing nut onto a straight flared fitting, it may be necessary to also place a wrench on the flared fitting wrench pad to prevent it from turning during assembly.

ALTERNATE ASSEMBLY METHOD

STEP 1: Inspect for possible contamination or damage from shipping or handling. Sealing surface should be smooth.

STEP 2: Lubricate the threads and the entire surface of the cone with hydraulic fluid or a light lubricant.

STEP 3: Align mating components for hand connection and turn flare nut until sealing surfaces make full contact.

STEP 4: Lightly wrench tighten the nut until there is resistance.

STEP 5: Place a wrench on wrench pad next to nut as near the 6 o'clock position as possible.

STEP 6: Place second wrench on nut as near the 3 o'clock position as possible.

STEP 7: Turn nut clockwise to no less than the 4 o'clock position, but no more than the 6 o'clock position. Required rotation generally decreases as size increases.

ADAPTER INSTALLATION PROCESS

ORB (O-RING BOSS) THREAD IDENTIFICATION & TORQUE

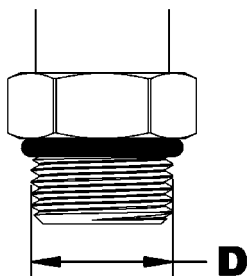

D		Identification of adapter	TORQUE	
in	mm		lbs-ft	N-m
-		3/8 ORB	8-9	12-13
0.433	11	7/16 ORB	13-15	18-20
0.496	12.6	1/2 ORB	14-15	19-21
0.559	14.2	9/16 ORB	23-24	32-33
0.740	18.8	3/4 ORB	40-43	55-57
0.870	22.1	7/8 ORB	43-48	59-64
1.055	26.8	1 1/16 ORB	68-75	93-101
1.185	30.1	1 3/16 ORB	83-90	113-122
1.307	33.2	1 5/16 ORB	112-123	152-166
1.618	41.1	1 5/8 ORB	146-161	198-218
1.870	47.5	1 7/8 ORB	154-170	209-230
2.492	63.3	2 1/2 ORB	218-240	296-325

SAE O-rings (O-Ring Boss) are straight thread fittings that seal using an O-ring between the thread and the wrench flats of the fitting. The O-ring seals against the machined seat on the female port.

O-ring fittings can be either adjustable or non-adjustable. Non adjustable fittings are screwed into a port where no alignment is needed. Adjustable fittings can be oriented in a specific direction.

Fittings with O-rings offer advantages over metal-to-metal fittings. Under or over-tightening any fitting can allow leakage, but all-metal fittings are more susceptible to leakage because they must be tightened to a higher and narrower torque range. This makes it easier to strip threads or crack or distort fitting components, which prevents proper sealing.

NOTE: Do not apply thread sealant (teflon tape) on the ORB threads.

Leaks can also result from vibration, thermal cycling and from loads being supported by the connection (i.e. using the fitting in the connection to support mechanical loads).

IMPORTANT: Use the lowest torque value from the chart when wet torquing.

RECOMMENDED ASSEMBLY **ORB (O-RING) NON-ADJUSTABLE**

STEP 1: Inspect all components for damage or contamination.

STEP 2: Lubricate O-ring and threads on fitting with the same hydraulic fluid used in the tractor.

STEP 3: Turn fitting into port until finger tight, then torque to the value shown in the following table.

NOTE: Use the lowest torque value from the chart when wet torquing.

RECOMMENDED ASSEMBLY **ORB (O-RING) ADJUSTABLE**

STEP 1: Inspect all components for damage or contamination.

STEP 2: Lubricate O-ring and threads on fitting with the same hydraulic fluid used in the tractor.

STEP 3: Looking at fitting from the male ORB end, turn manually the nut as far as possible from the O-ring.

STEP 4: Using wrench, turn fitting into port until the washer touches thread nearest wrench pad.

STEP 5: Back off fitting counterclockwise not exceeding one revolution until it is oriented in the correct position.

STEP 6: Place wrench on the wrench pad of fitting to prevent fitting from turning, and torque nut to the value shown in the above table.

Manufactured by:



Dalkotech Group

RAD Technologies Inc.
2835, Chemin de l'Aéroport
Thetford Mines, Québec, Canada, G6G 5R7

T +1 418 338-4499 - F +1 418 338-2522

info@radtech.ca
radtech.ca

Printed in Canada