

# FERRI<sup>®</sup>

Boom mowers for agriculture  
and green areas

**T460**  
*SMART*



# T460

SMART

An innovative project for a modern agriculture. An ambitious task was given to the Ferri technical department: to realize a compact, reliable, strong and lightweight boom mower. In collaboration with the Institute IMAMOTER CNR we managed to reduce weight thanks to

an innovative oil tank in polypropylene. The reliability and strength are ensured by the new Delta Box frame. Compact but powerful, the pump engaging the rotor is entirely cast iron made.

## Boom mowers for agriculture and green areas



The polypropylene oil tank is separated from the frame and allows it to be isolated from any structural stress. Fully recyclable.



Developed and tested in collaboration with:

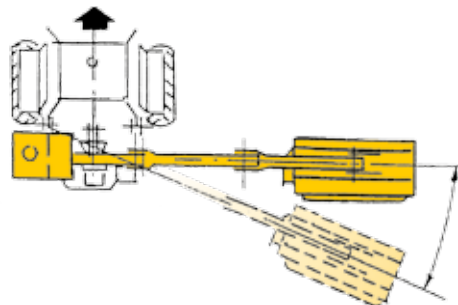

Mechanical breakaway (arm protection in case of obstacles)

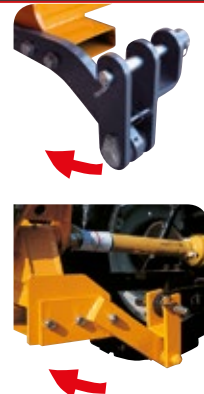

"Overlap" spiral rotor with two spiral rows.

# FERRI®



Left hand version



Flail head angle 190°



Cast iron hydraulic rotor pump group 3



Cable controls

## IMPLEMENTS



Cutter bar





# Boom mowers for agriculture and green areas



| Technical data        |         | T460 SMART  |
|-----------------------|---------|-------------|
| <b>Model</b>          |         | <b>DUAL</b> |
| Max horizontal reach* | ft      | 15'1"       |
| 3 Points Linkage      | Cat.    | II          |
| Weight                | lbs     | 1279        |
| Oil                   | gal     | 31,7        |
| P.t.o.                | MAX Rpm | 540         |

\* Reach measured from tractor centre line to head edge.

| Flail head                          |           | TIM110    |  <p><b>TIM110</b><br/>Direct Drive<br/>Cast iron motor</p> |
|-------------------------------------|-----------|-----------|---|
| Width of cut                        | ft        | 3'5"      |   |
| Rotor speed                         | Rpm       | 3100      |   |
| Blade tip speed                     | ft/sec    | 196       |   |
| Flail head angle                    |           | 190°      |   |
| Weight                              | lbs       | 286       |   |
| <b>Power available to the rotor</b> | <b>HP</b> | <b>35</b> |   |
| <b>Power max to hydraulic motor</b> | <b>HP</b> | <b>45</b> |   |

| Tractor                |   |   |           |           |           |          |
|------------------------|---|---|-----------|-----------|-----------|----------|
| <b>HP</b>              |  |  | <b>50</b> | <b>60</b> | <b>70</b> |          |
|                        |   |   |           |           |           |          |
| <b>T460 SMART DUAL</b> |   |   |           |           | 4850 lbs  | 5'11" ft |

| Flails  |                                   | N°  |
|---|-----------------------------------|---|
| <b>TIM110</b>   | Interchangeable on the same rotor |   |
| Multi-use and straight blades for: grass, shrubs, bushes, sticks, wood. | Ø max 1 3/4"                      |  32+16 |

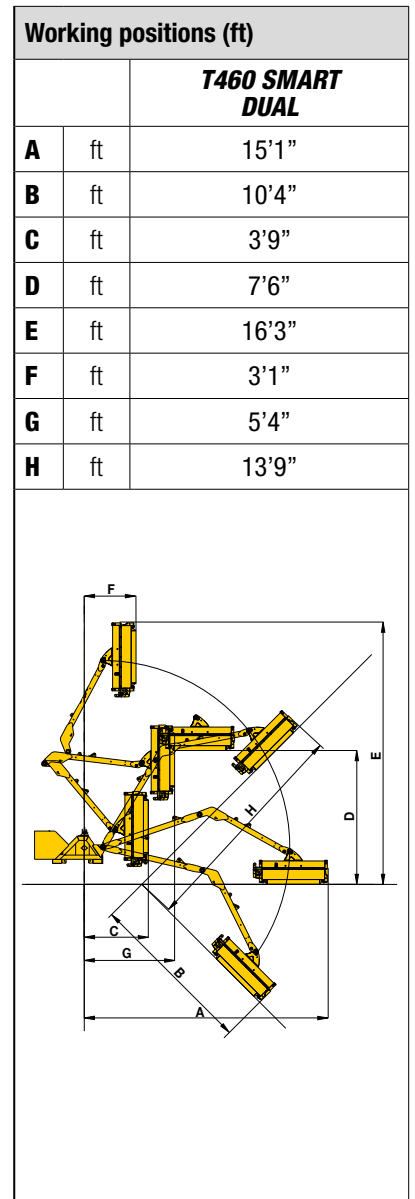

All data subject to change  
campbelladv.com 77314 T460 - USA - EN Rev.1 - 1150

[www.ferri-america.com](http://www.ferri-america.com)



**FERRI srl**  
Via Govoni, 30  
44034 Tamara (FE) Italy  
Tel. +39 0532 866866  
Fax +39 0532 866851  
info@ferri-srl.it - www.ferri-srl.it



**North America Sales and Marketing Manager / FERRI**  
Ronald E. Roglis  
Glenarm, Illinois 62536  
Cell (314) 422-9460  
Fax (217) 483-4123  
E-mail: ron.roglis@gmail.com

**Parts Stock / FERRI:**  
J.S. Woodhouse Co., Inc.  
1314 Union Street  
P.O. Box 1169  
West Springfield, Ma. 01090 U.S.A.  
tel. 413-736-5462  
fax 413-732-3786  
info@jswoodhouse.com