

AGRICULTURAL MACHINERY

sitrex®
Spa

ASSEMBLY

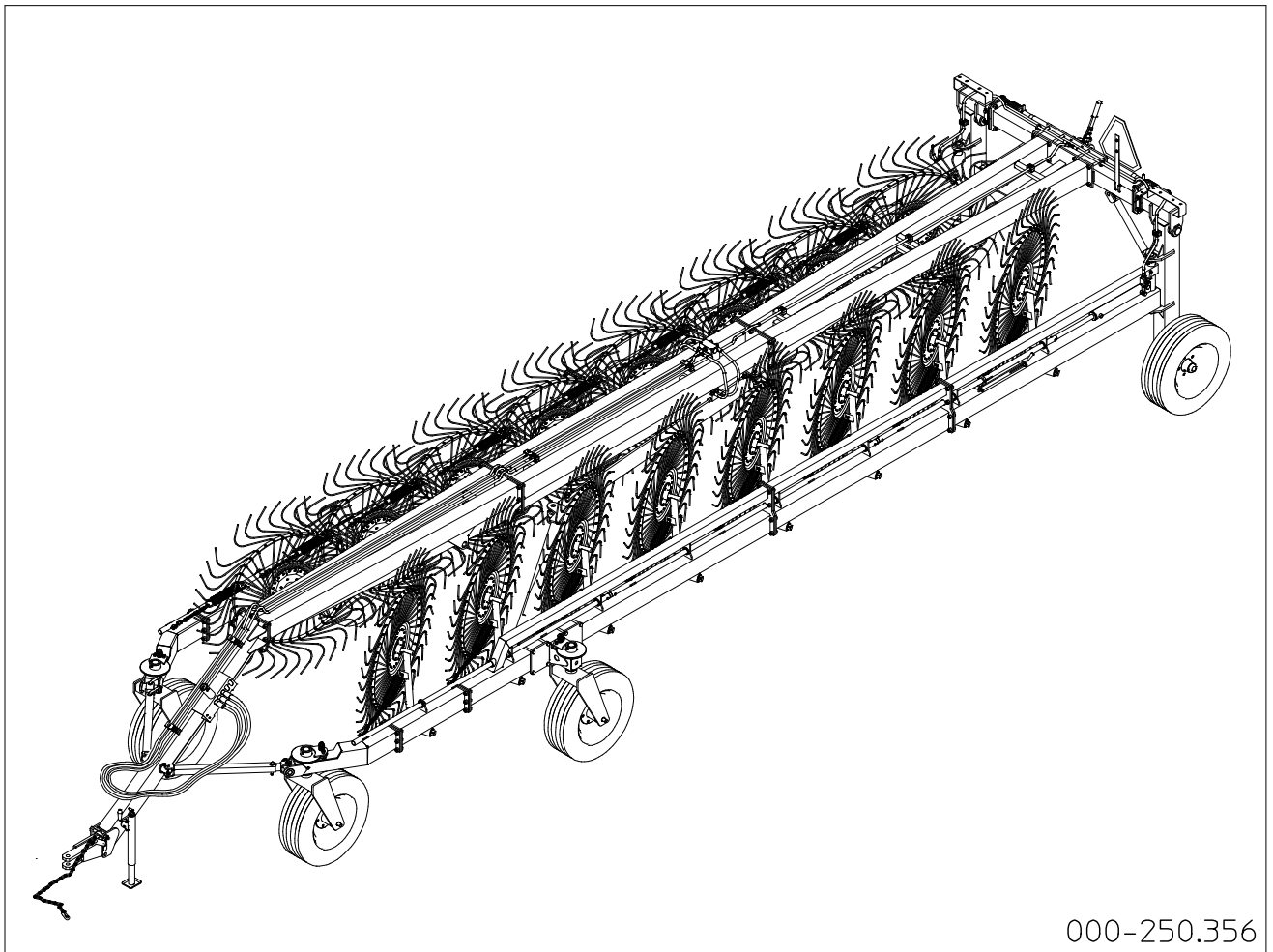

MKE/14-16

12-2014

Assembly Instructions

Examples of general measurements for identifying assembly accessories according to type.

To make it easier to identify the assembly accessories (nuts, bolts, washers, pins, etc.) on the basis of the general dimensions and the type, we provide a diagram that shows you the accessory parts to which the measurements refer as given in the various steps of assembly.

The drawings are schematic and do not always faithfully reproduce the accessories, but they will be of help in identifying them correctly.

Note: the accurate measurements are those given in mm; those given in inches are rounded off, and for threads the size in inches is given only as an aid, as it does not accurately describe the thread.

You can see the following examples:

Box “A”: shows springs that will be identified by the wire diameter, the outside diameter and the length, thus in this case $\emptyset 3\text{-}\emptyset 18 \times 110$ ($\emptyset 0.12\text{''-}\emptyset 0.71\text{''} \times 4.33\text{''}$)

Box “B”: shows handles, spring pins, split pins, etc. that will be identified by the diameter of the shank and the length, thus in this case $\emptyset 8 \times 50$ ($\emptyset 0.12\text{''} \times 1.97\text{''}$)

Box “C”: shows shims, bushings, spacers and washers in general that will be identified by the inside diameter, the outside diameter and the length and/or the thickness (for washers), thus in this case $\emptyset 18\text{-}\emptyset 35 \times 30$ ($\emptyset 0.71\text{''-}\emptyset 1.38\text{''} \times 1.18\text{''}$) or for washers $\emptyset 18\text{-}\emptyset 35 \times 3$ ($\emptyset 0.71\text{''-}\emptyset 1.38\text{''} \times 0.12\text{''}$).

Box “D”: shows retaining rings for internal housings/bores that will be identified by the diameter of the bore preceded by an I, thus in this case I35-1.38”, and for external shafts that will be identified by the diameter of the pin preceded by an E, thus in this case E35-1.38”.

Box “E”: shows pins, bolts, etc. that will be identified by the outside diameter (thread diameter for bolts) and the length, thus in this case $\emptyset 20 \times 70$ ($\emptyset 0.78\text{''} \times 2.76\text{''}$) or for bolts M20 x 70 (0.78” x 2.76”).

Box “F”: shows nuts and grease nipples that will be identified by the thread diameter, thus in this case M10 (0.39”).

Box “G”: shows R-clips that will be identified by the diameter of the shank, thus in this case $\emptyset 3$ ($\emptyset 0.12\text{''}$).

Assembly Instructions

Examples of general measurements for identifying accessories for assembly according to type.

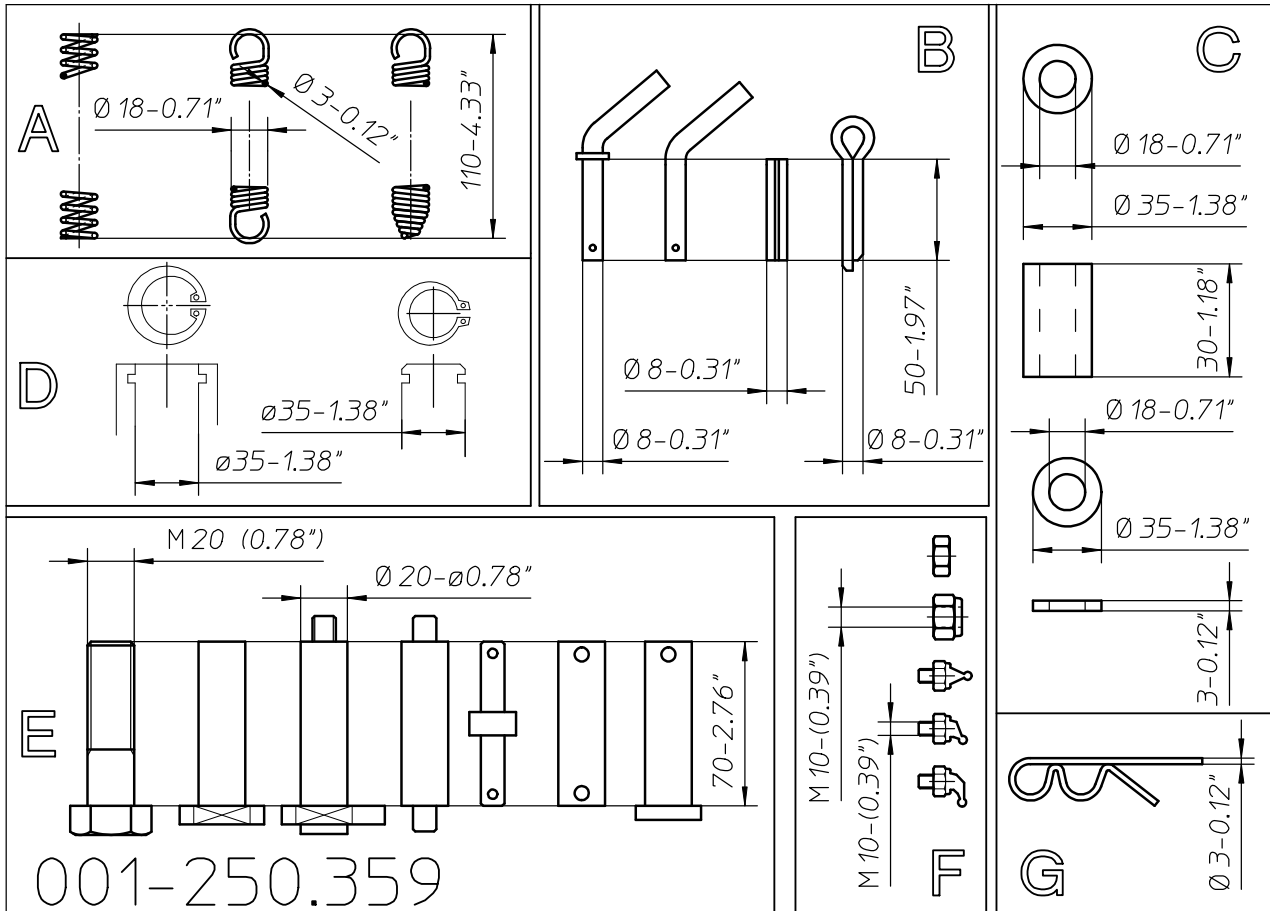

For tightening torques, see the table below (the class of the material is normally stamped on the head of the bolts).

MINIMUM HARDWARE TIGHTENING TORQUES

IN NEWTON-METERS (FOOT POUNDS) FOR NORMAL ASSEMBLY APPLICATIONS

METRIC NON-FLANGED HARDWARE AND LOCKNUTS

NOMINAL SIZE	CLASS 5.8		CLASS 8.8		CLASS 10.9		LOCKNUT CL.8 W/CL.8 BOLT
	UNPLATED	PLATED W/ZnCr	UNPLATED	PLATED W/ZnCr	UNPLATED	PLATED W/ZnCr	
M4	1.7 (15)*	2.2 (19)*	2.6 (23)*	3.4 (30)*	3.7 (33)*	4.8 (42)*	2.3 (20)*
M6	5.8 (51)*	7.6 (67)*	8.9 (79)*	12 (102)*	13 (115)*	17 (150)*	7.8 (69)*
M8	14 (124)*	18 (159)*	22 (195)*	28 (248)*	31 (274)*	40 (354)*	19 (169)*
M10	28 (21)	36 (27)	43 (32)	56 (41)	61 (45)	79 (58)	38 (28)
M12	49 (36)	63 (46)	75 (55)	97 (72)	107 (79)	138 (102)	66 (49)
M16	121 (89)	158 (117)	186 (137)	240 (177)	266 (196)	344 (254)	164 (121)
M20	237 (175)	307 (226)	375 (277)	485 (358)	519 (383)	671 (495)	330 (243)
M24	411 (303)	531 (392)	648 (478)	839 (619)	897 (662)	1160 (855)	572 (422)

NOTE: Torque values shown with * are inch pounds.

General assembly instructions for all models in the MK series.

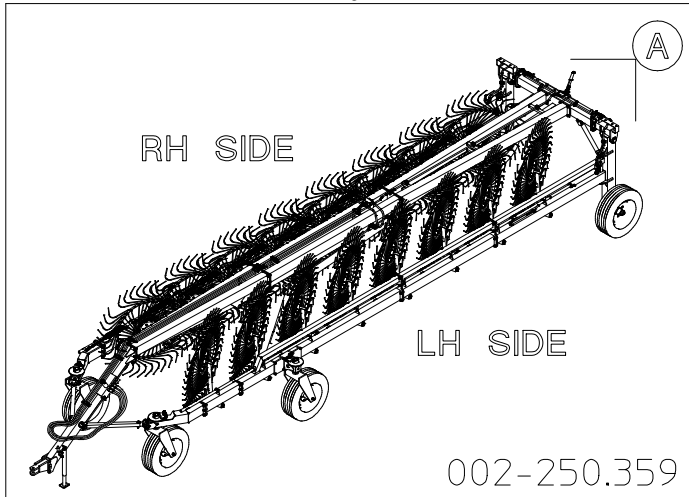

As regards the indicating of right/left, they are understood to be attributed observing the machine from point A (behind the machine) looking forward.

The machine must be assembled in a suitable area, done by qualified personnel equipped with the proper clothing, protective equipment and tools necessary for the job. Only authorized persons should be in the assembly area.

Assembly is correct when the various RH sections A, C, E, etc. and the various LH sections B, D, F, etc. are aligned and parallel to each other and when the coupling flanges G between one section and another are flush. NOTE: since these are sections to be joined by means of welded flanges, there will not be perfect linearity between RH sections A, C, E, etc. and LH sections B, D, F, etc. thus a certain margin of error must be tolerated. To reduce this error to a minimum, a few small techniques must be used. For example, tighten the flange coupling bolts, one outside 1 and one inside 2, if the RH sections A, C, E, etc. and LH sections B, D, F, etc. are linear; or tighten first the outside bolts 3-4 if the sections tend to curve toward the inside of the machine, and vice versa tighten first the inside bolts 5-6 if the sections tend to curve toward the outside.

The alignment of the sections is important, as it also affects the assembly of the rake wheel lifting pipes and how they slide along supports H during use. Bearing in mind this advice, you can proceed with the assembly following the steps illustrated in following. Unless otherwise specified, the assembly is shown for just one side of the machine, but as it is symmetrical, simply repeat the same steps on the other side as well. The quantities of the materials to be used for the various assembly steps refer to both sides of the machine. The weights given near the major components may vary by +/- 5%.

NOTE: What we are about to describe is an approximate assembly procedure. Each person, based on their experience and on the tools they have to work with, may vary the assembly steps to suit their needs. **Always use great caution because the assembly steps are dangerous.**

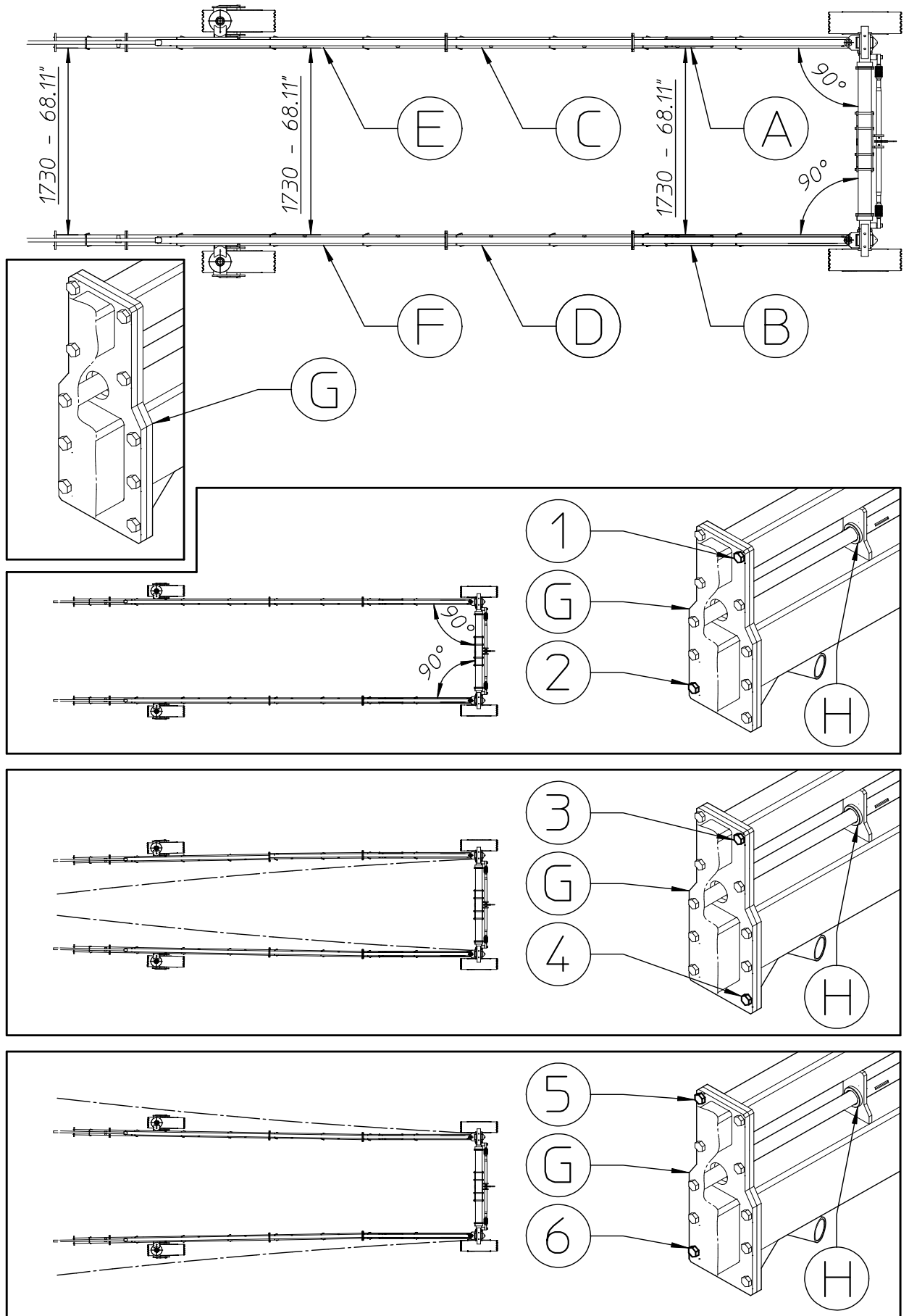

003-250.359

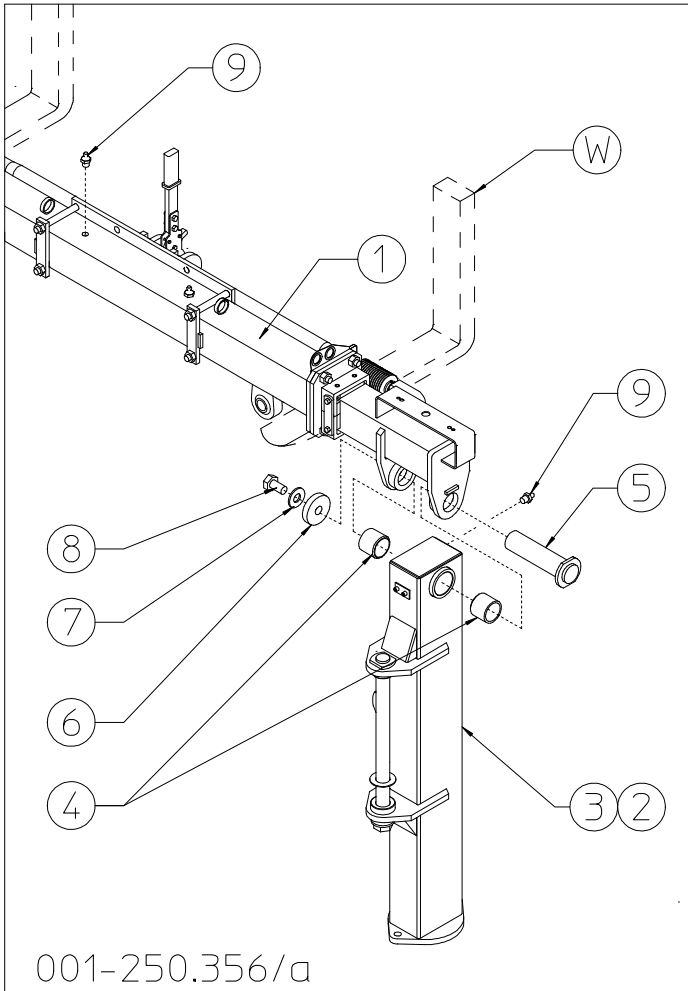

1) DANGER

Insert bushings 4 in the openings in supports 2-3 (RH/LH - 40kg/88lbs). Lift unit 1 (weight 110kg/245lbs) with a suitable forklift W. Connect the vertical supports 2-3 to the crosspiece assembly 1 using pin 5, washers 6-7 and bolt 8.

Insert the grease nipples 9 into the openings in supports 2-3 and in the crosspiece assembly 1.

In this step, you will use:

Item 4: 4 bushings $\varnothing 50-60 \times 50$ ($\varnothing 1.97'' - 2.36'' \times 1.97''$)

Item 5: 2 pins $\varnothing 50 \times 190$ ($\varnothing 1.97'' \times 7.5''$)

Item 6: 2 spacers $\varnothing 23-75 \times 12$ ($\varnothing 0.91'' - 2.95'' \times 0.47''$)

Item 7: 2 split washers $\varnothing 23-35 \times 4$ ($\varnothing 0.91'' - 1.38'' \times 0.16''$)

Item 8: 2 bolts M22x50 ($0.87'' \times 1.97''$)

Item 9: 4 grease nipples M8 ($0.32''$)

2) DANGER

Work very carefully because the unit assembled so far is very unstable. To make sure that the supports 2-3 have been attached correctly to unit 1, check that the dimensions are those given in the drawing at the side.

Note: The central holes A in the lower flanges of supports 2-3 must be on the inside.

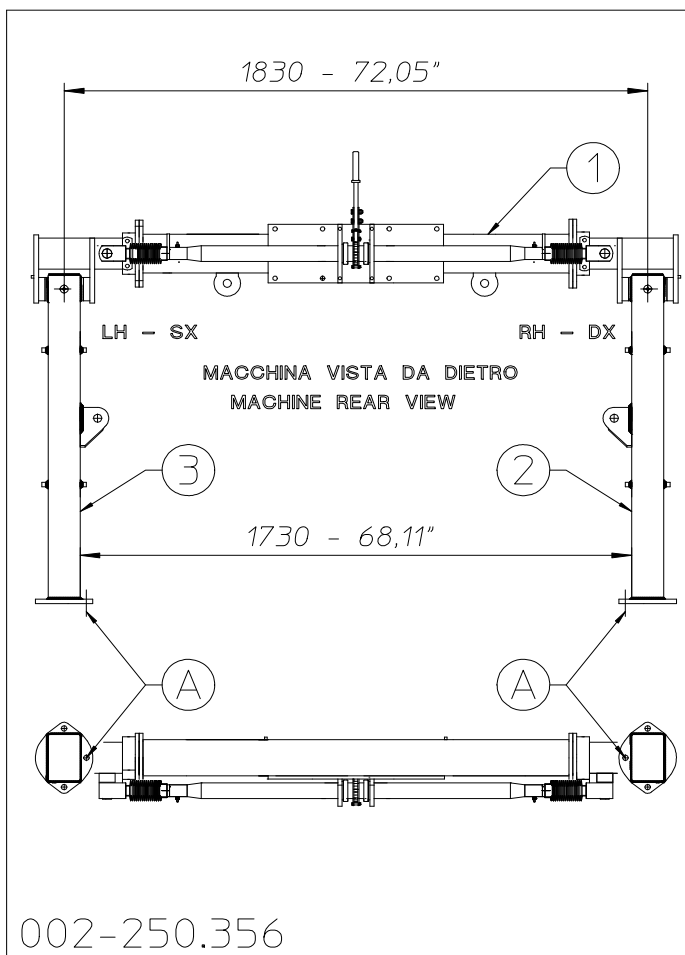

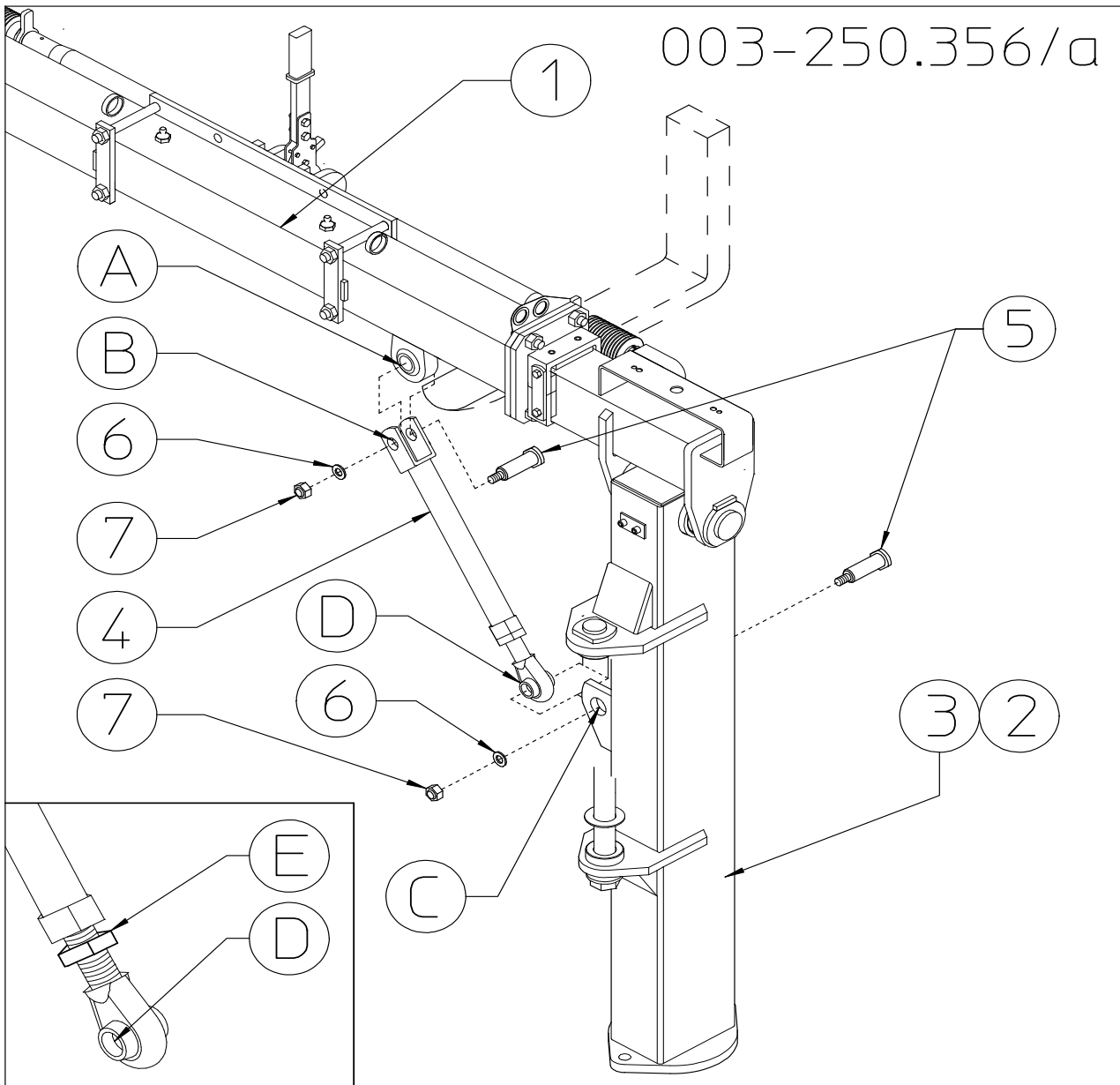

3) DANGER

The tie rod 4 is preassembled to the right size for it to be attached to seat A on the crosspiece assembly 1 and to seats C on the vertical supports 2-3. Part B of tie rod 4 goes to seat A on the crosspiece assembly 1 and part D goes to seat C on the vertical supports 2-3. If a small adjustment must be made to adjust the length, loosen nut E, rotate the head D until it reaches the right length, then lock in place with nut E. Connect fork B on tie rod 4 to seat A on the crosspiece assembly 1 and part D of tie rod 4 to part C of supports 2-3 using the pins 5, washers 6 and nuts 7.

In this step, you will use:

Item 5: 4 pins $\varnothing 25 \times 58$ ($\varnothing 1'' \times 2.28''$)

Item 6: 4 washers $\varnothing 12-36 \times 4$ ($\varnothing 0.47'' - 1.42'' \times 0.16''$)

Item 7: 4 nuts M12 (0.47'')

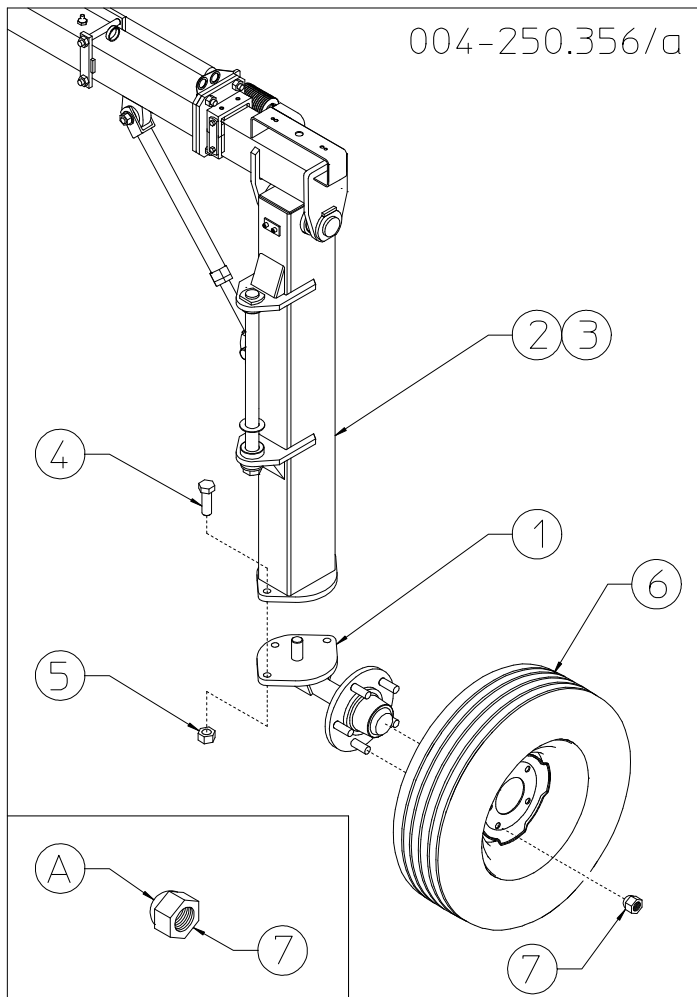

4) DANGER

Attach the wheel hubs 1 to vertical supports 2-3 using bolts 4 and nuts 5. Attach the wheels 6 to the hubs 1 and fasten with the special nuts 7. Note: the rounded part A of the special nut 7 should be applied facing the wheel 6.

In this step, you will use:

Item 4: 6 bolts M16x50
(0.63"x1.97")

Item 5: 6 nuts M16 (0.63")

Item 7: 10 special nuts M16x1.5
(0.63")

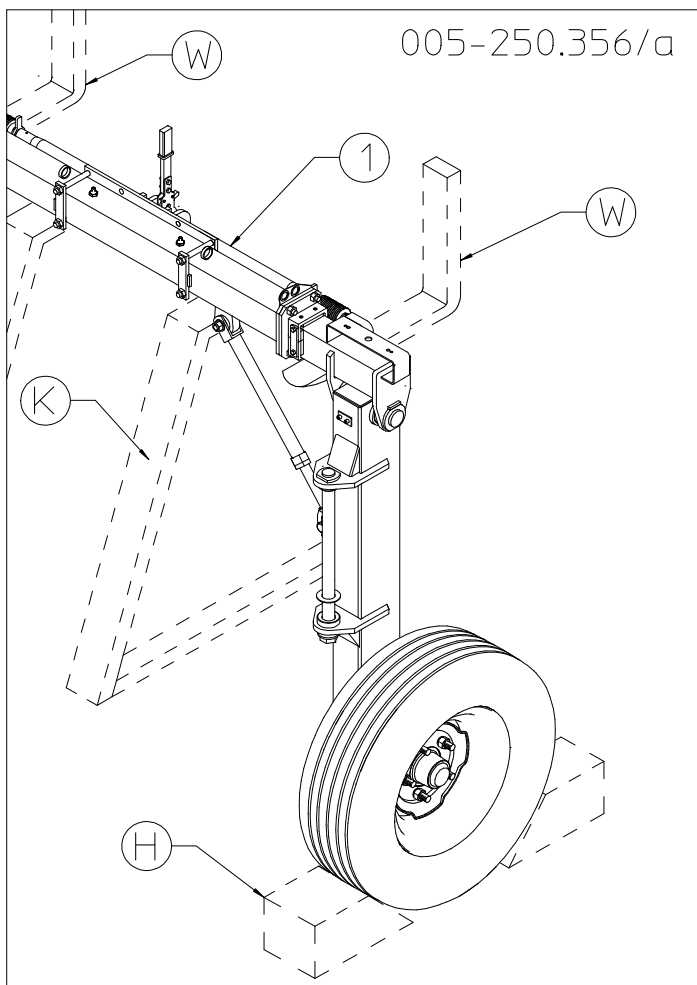

5) DANGER

To continue with the assembly, unit 1 must be stabilized. This can be done either with a support K or with a forklift W. Chocks H must also be applied to the wheels. Proceed with caution in the next assembly steps, even with the unit stabilized.

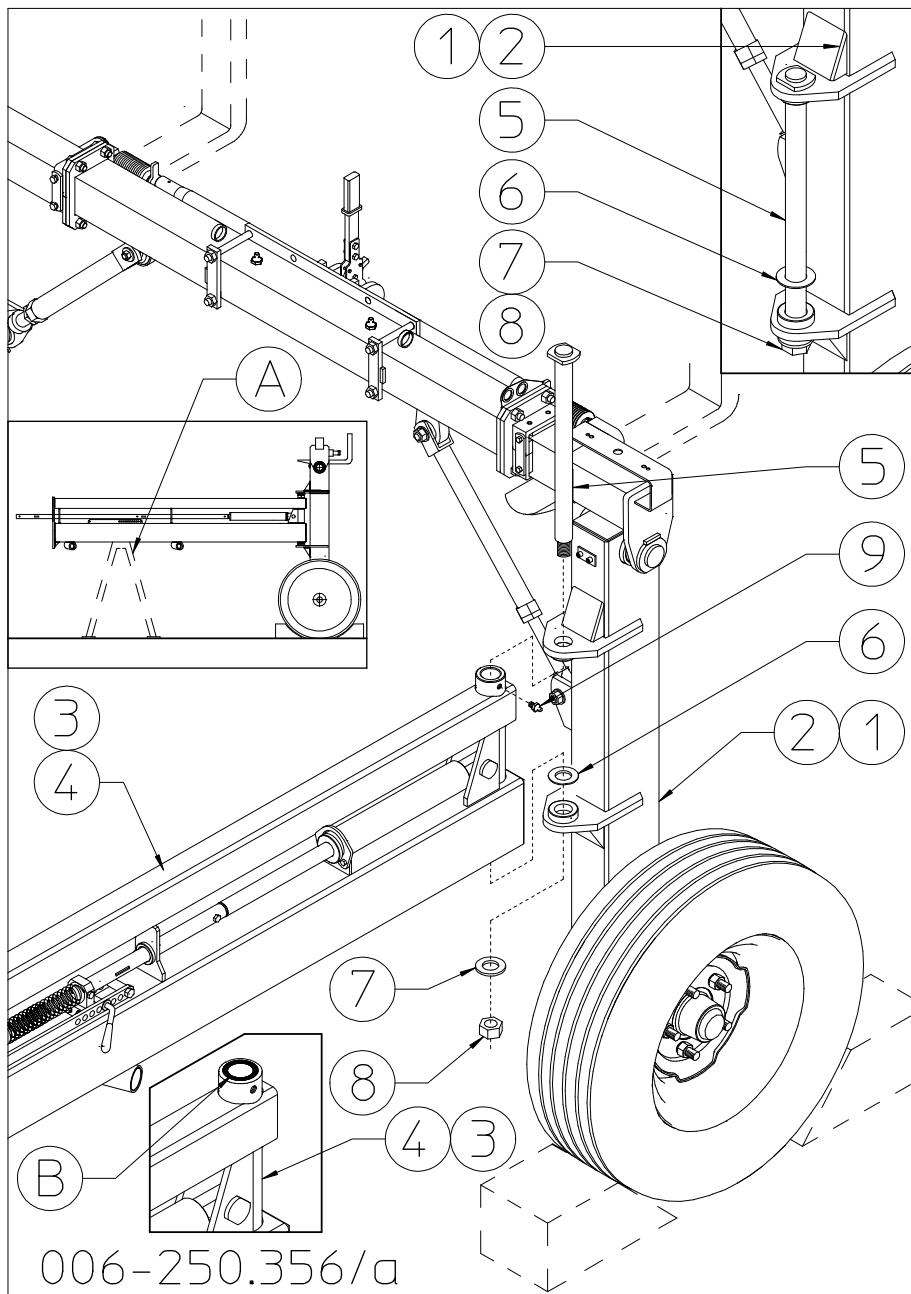

6) DANGER

Check that manufacturer has assembled on the vertical supports 1-2 (RH-LH) the pins 5, spacers 6, washers 7 and nuts 8 that you will use for assembly in the order in which you find them assembled.

Check that manufacturer has assembled the bushings B to their seats on sections 3-4 (RH-LH).

Now attach sections 3-4 (RH-LH) to the seats on the vertical supports 1-2 (RH-LH) using the pin 5, spacer 6, washers 7 and nuts 8.

Once sections 3-4 are attached, set them on a support A. Now apply the grease nipples 9 to the openings in sections 3-4.

6) DANGER

In this step, you will use:

Item 5: 2 pins $\varnothing 35 \times 450$ ($\varnothing 1.38'' \times 17.72''$)

Item 6: 2 spacers $\varnothing 35-52 \times 1.5$ ($\varnothing 1.38''-2.05'' \times 0.06''$)

Item 7: 2 washers $\varnothing 23-50 \times 4$ ($\varnothing 0.91''-1.97'' \times 0.16''$)

Item 8: 2 nuts M22 (0.87'')

Item 9: 2 grease nipples M8 (0.32'')

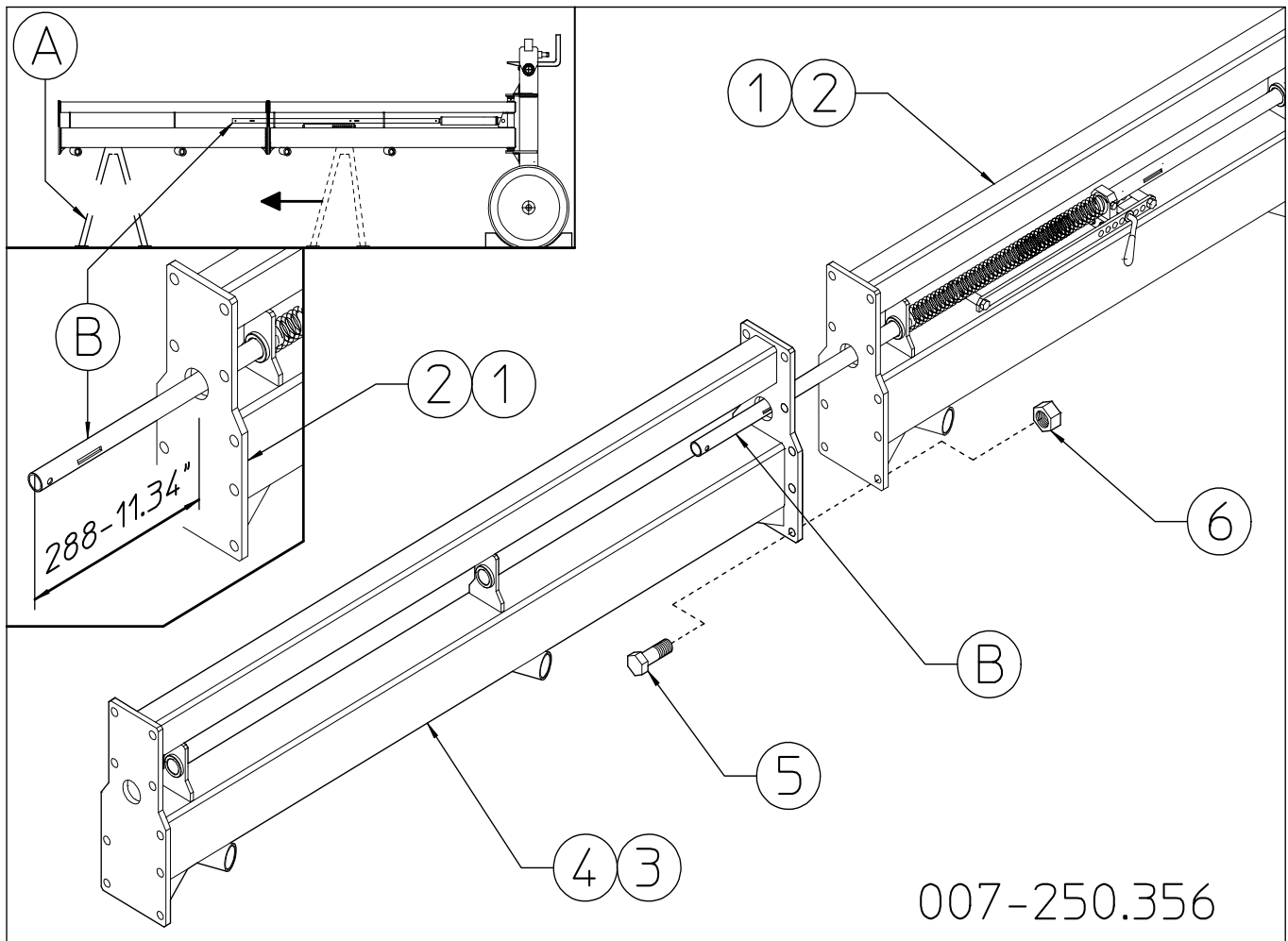

7) DANGER

Check that pipe B protrudes about 288mm-11.34” from section 1-2. Note: this measurement is with the cylinder to which it is attached completely closed, and the total pipe length must be 1670 mm – 65.75”.

Now attach sections 3-4 (RH-LH – 65kg/143lbs) to sections 1-2 (RH-LH) using bolts 5 and nuts 6.

Note: Once sections 3-4 are attached, move support A forward or use an additional support.

In this step, you will use:

Item 5: 20 bolts M16x45 (0.63”x1.77”)

Item 6: 20 nuts M16 (0.63”)

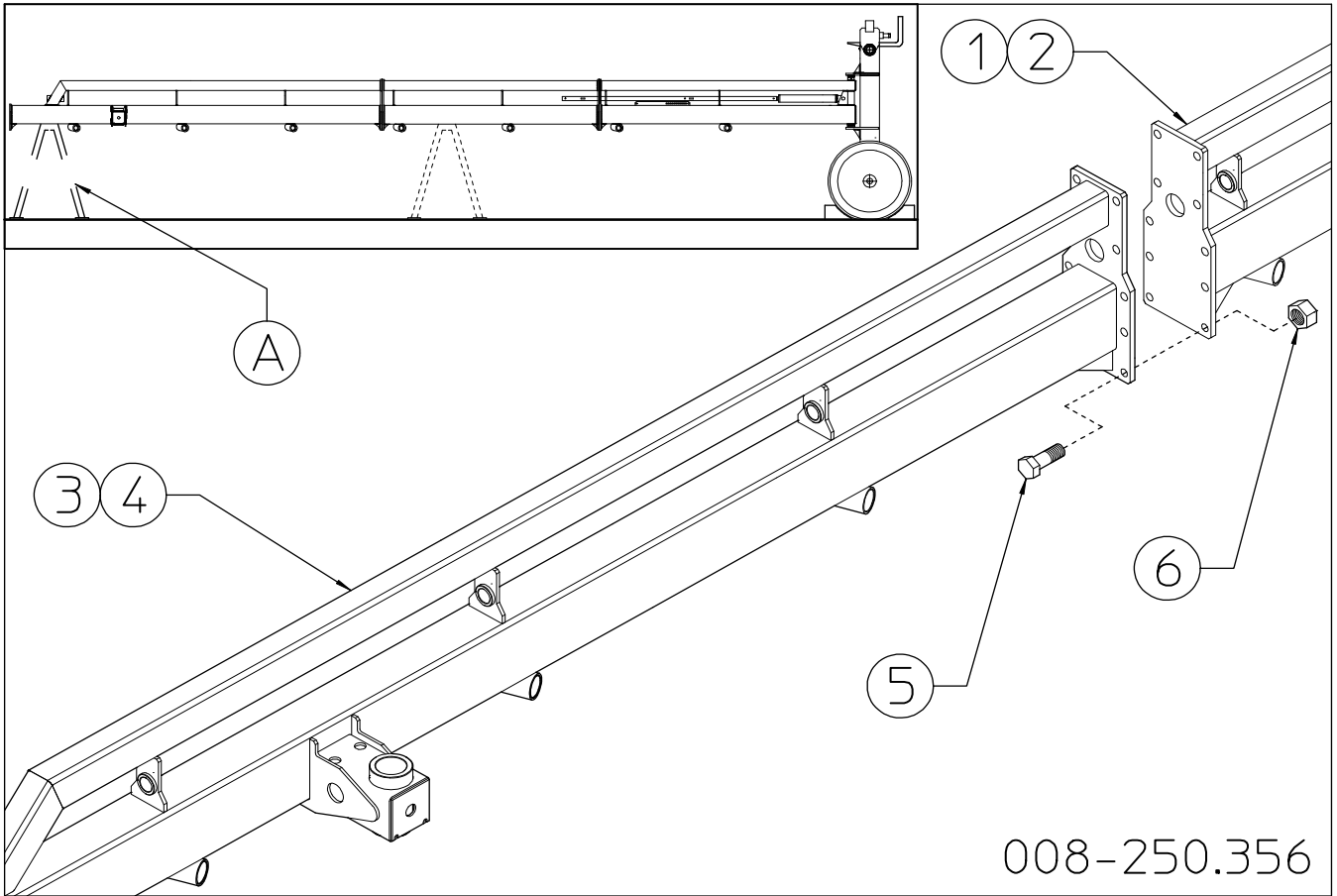

8) DANGER

Now attach sections 3-4 (RH-LH – 105kg/230lbs) to sections 1-2 (RH-LH) using bolts 5 and nuts 6.

In this step, you will use:

Item 5: 20 bolts M16x45 (0.63"x1.77") - Item 6: 20 nuts M16 (0.63")

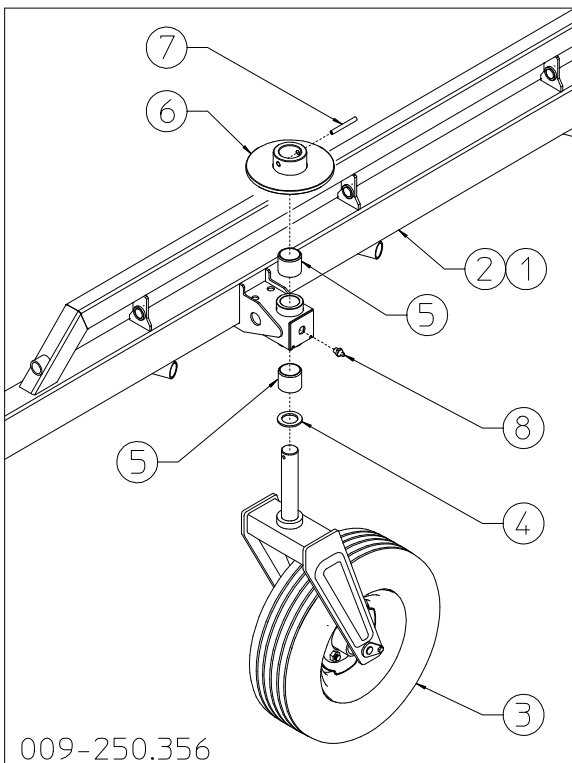

9) DANGER

Insert the nylon bushings 5 into the openings in sections 1-2 (RH-LH). Place spacer 4 on the pins of the wheel units 3. Insert the wheel units 3 into the openings in sections 1-2.

Attach the flange 6 onto the pins of the wheel units 3 using the spring pins 7. Attach the grease nipples 8 to the openings in sections 1-2.

Before continuing make sure that the wheel units 3 can turn freely.

In this step, you will use:

Item 4: 2 spacers $\varnothing 50-76 \times 5$ (1.97"x3")

Item 5: 4 nylon bushings $\varnothing 50-60 \times 50$ ($\varnothing 1.97''-2.36 \times 1.97''$)

Item 7: 2 spring pins $\varnothing 10 \times 80$ (0.4"x3.15")

Item 8: 2 grease nipples M8 (0.31")

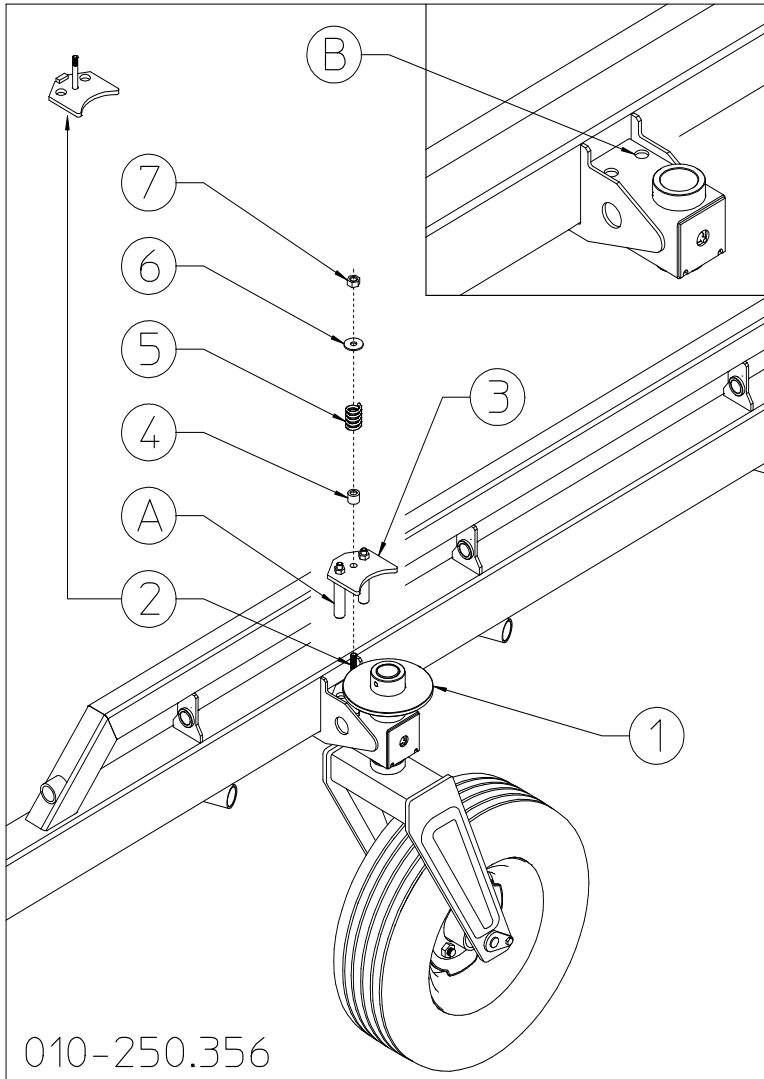

10) DANGER

Attach the plate with bolt 2 underneath flange 1. Attach the counterplate 3 over flange 1, inserting the counterplate pins A into the holes in the plate with bolt 2 and into holes B in the sections. Place the bushing 4, spring 5 and washer 6 over the plate 2 bolt and put nut 7 on the bolt.

Note: the more spring 5 is compressed by tightening nut 7, the more the turning of the wheel is braked, therefore check that it is adjusted properly when the machine is to be operated (see machine use).

In this step, you will use:

Item 4: 2 bushings $\varnothing 13-18 \times 20$ (0.5"-0.71"x0.79")

Item 5: 2 springs $\varnothing 5-30 \times 45$ (0.20"-1.18"x1.77")

Item 6: 2 washers $\varnothing 12-36 \times 4$ ($\varnothing 0.47"-1.42 \times 0.16"$)

Item 7: 2 nuts M12 (0.47")

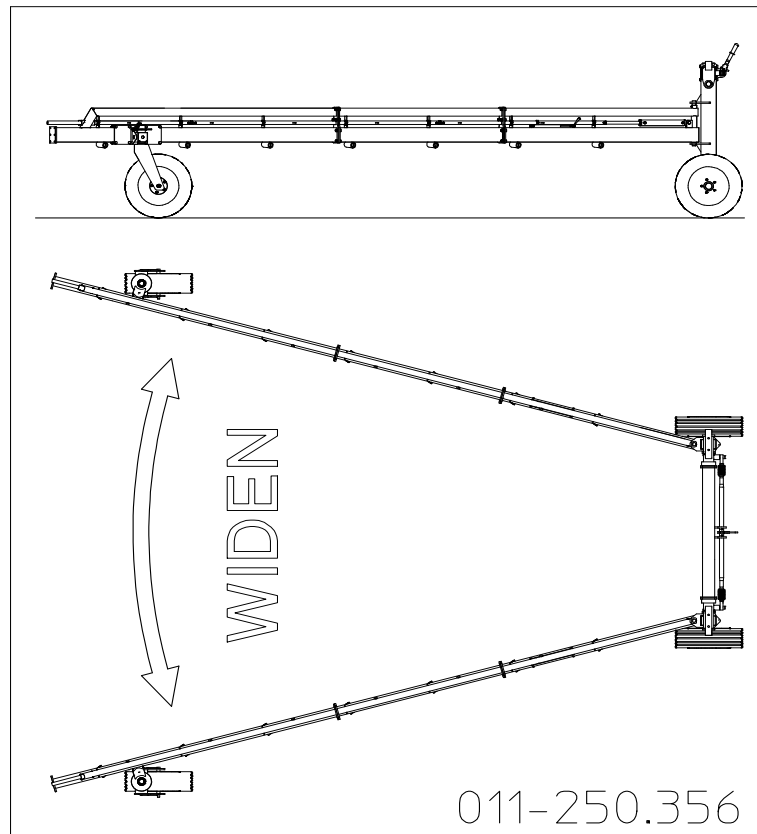

11)

You have now reached this stage of the assembly. The machine rests on its wheels and thus has good stability. However, continue to use great caution during the rest of the assembly, so as to work safely. In order to work better, spread apart the right and left sections of the machine.

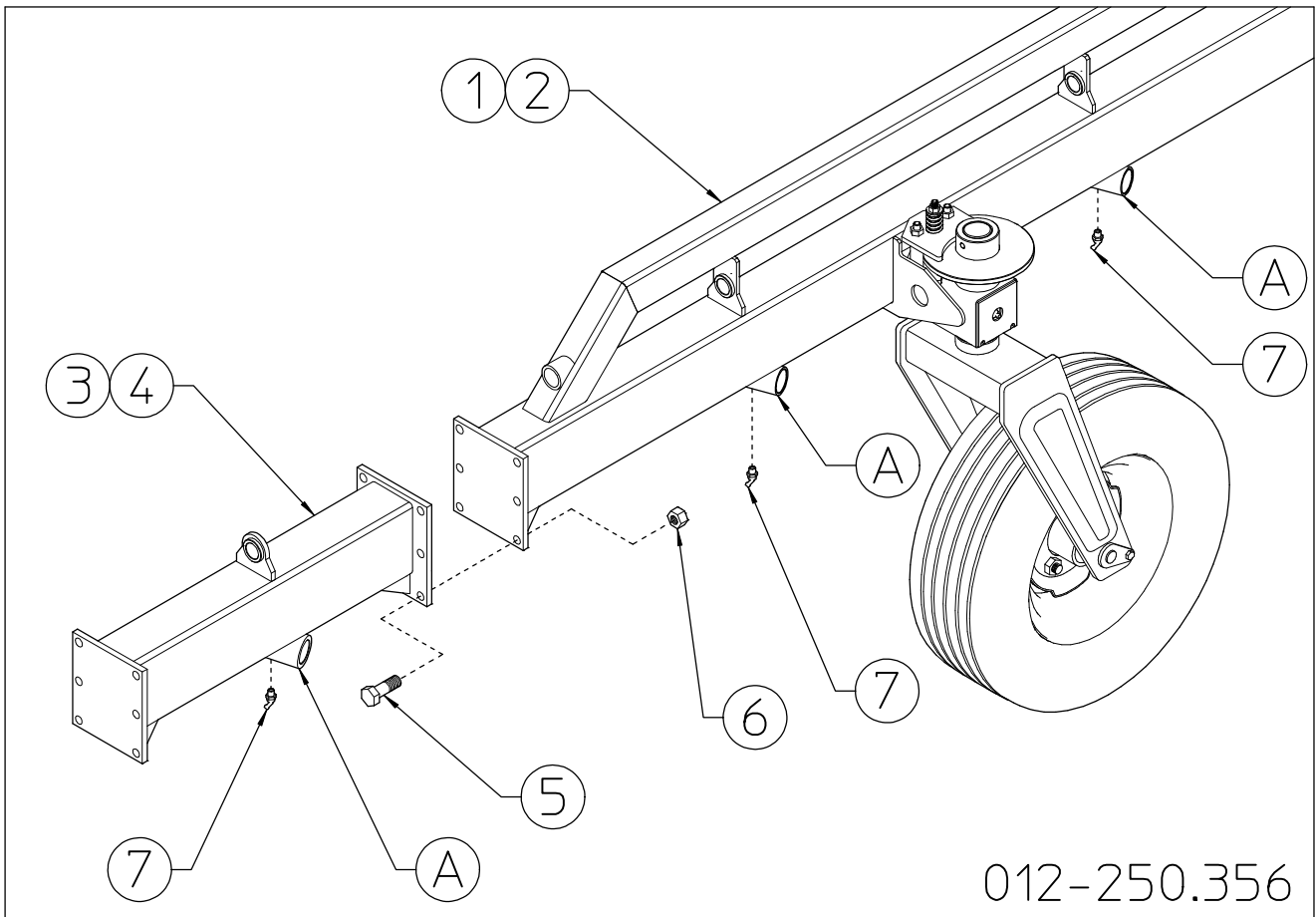

12) **DANGER**

Note: Sections 3-4 (RH-LH) are to be assembled only for MK/16.

Attach sections 3-4 (RH-LH) to sections 1-2 (RH-LH) using bolts 5 and nuts 6.

Note: For MK/14 and MK/16 – At this point the assembly of the sections is completed. Apply the grease nipples 7 to all the bushings A on all the RH and LH sections.

In this step, you will use:

Item 5: 12 bolts M16x45 (0.63"x1.77") (MK/16 only)

Item 6: 12 nuts M16 (0.63") (MK/16 only)

Item 7: 14 (MK/14) 16 (MK/16) grease nipples M6x45° (0.23"x45°)

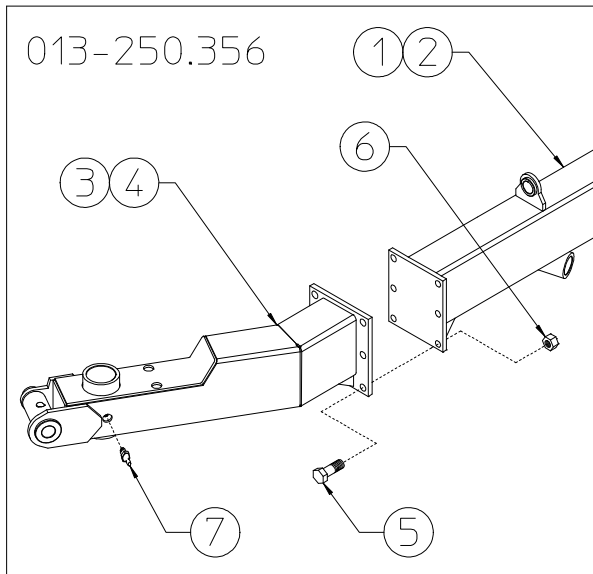

13) DANGER

Attach the wheel supports 3-4 to sections 1-2 (RH-LH) using bolts 5 and nuts 6.

Apply grease nipples 7 to the seats in wheel supports 3-4.

In this step, you will use:

Item 5: 12 bolts M16x45 (0.63"x1.77")

Item 6: 12 nuts M16 (0.63")

Item 7: 2 grease nipples M8 (0.31")

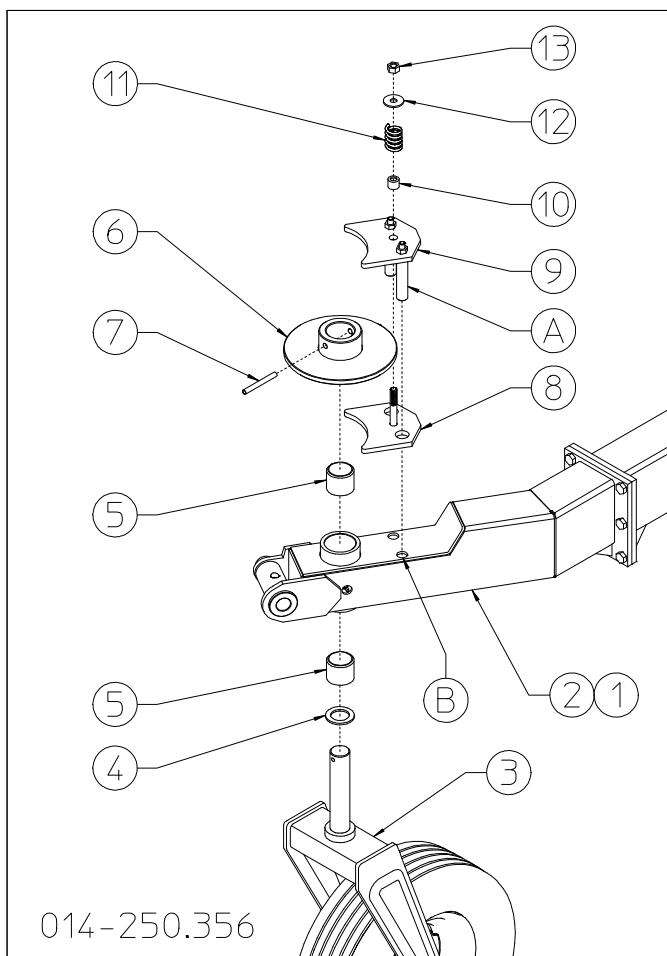

14) DANGER

Insert the nylon bushings 5 into the openings in support 1-2 (RH-LH). Place spacer 4 on the pins of the wheel units 3. Insert the wheel units 3 into the openings in sections 1-2. Attach the flange 6 onto the pins of the wheel units 3 using the spring pin 7.

Before continuing make sure that the wheel units 3 can turn freely.

Attach the plate with bolt 8 underneath flange 6. Attach the counterplate 9 over flange 6, inserting the counterplate pins A into the holes in the plate with bolt 8 and into holes B in the supports 1-2. Place the bushing 10, spring 11 and washer 12 over the plate 8 bolt and put nut 13 on the bolt.

Note: the more spring 11 is compressed by tightening nut 13, the more the turning of the wheel is braked, therefore check that it is adjusted properly when the machine is to be operated (see machine use).

14) DANGER

In this step, you will use:

Item 4: 2 spacers $\varnothing 50-76 \times 5$ (1.97"x3")

Item 5: 4 nylon bushings $\varnothing 50-60 \times 50$ ($\varnothing 1.97''-2.36 \times 1.97''$)

Item 7: 2 spring pins $\varnothing 10 \times 80$ (0.4"x3.15")

Item 10: 2 bushings $\varnothing 13-18 \times 20$ (0.5"-0.71"x0.79")

Item 11: 2 springs $\varnothing 5-30 \times 45$ (0.20"-1.18"x1.77")

Item 12: 2 washers $\varnothing 12-36 \times 4$ ($\varnothing 0.47''-1.42 \times 0.16''$)

Item 13: 2 nuts M12 (0.47")

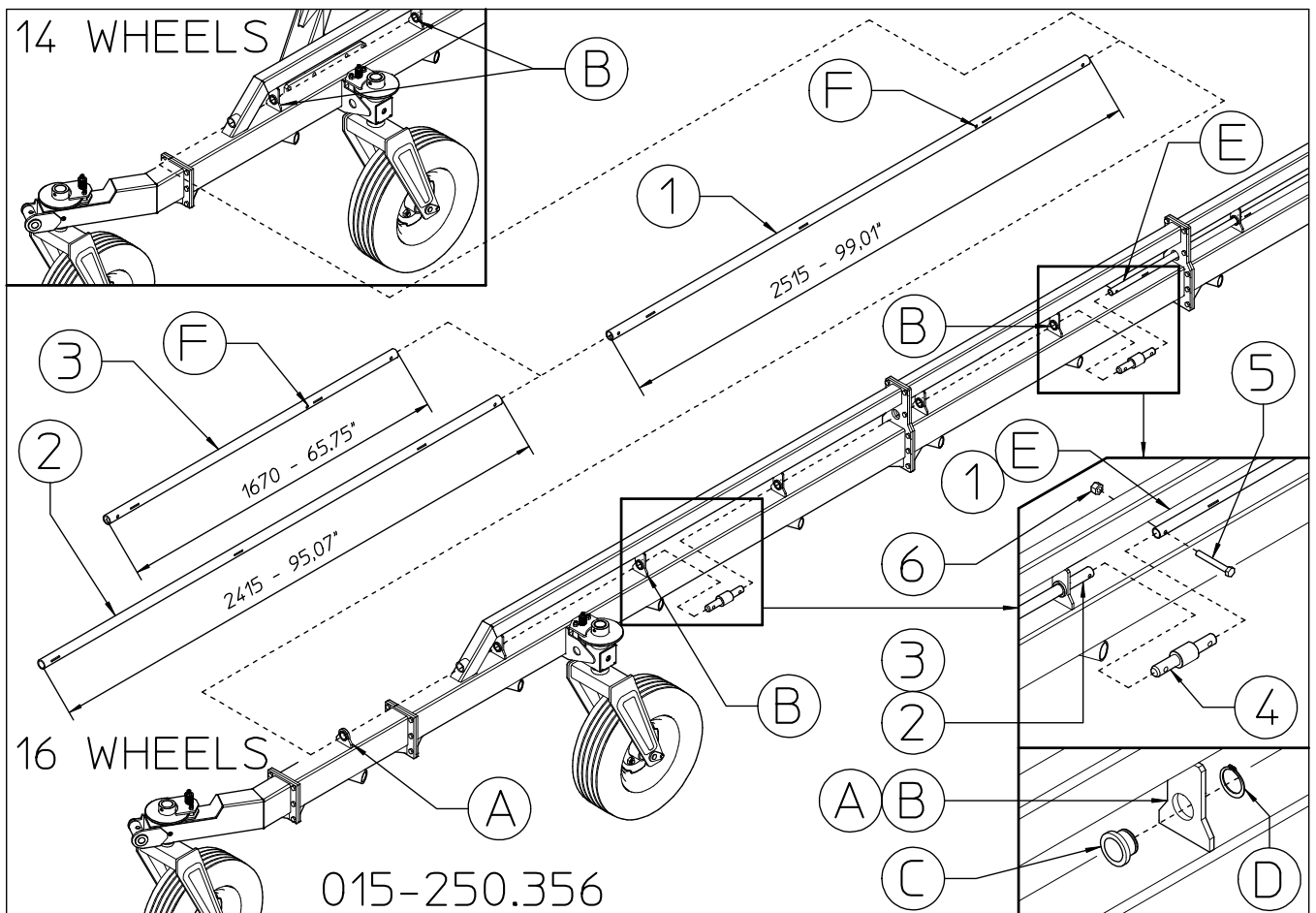

15) DANGER

Check to make sure the manufacturer has correctly secured the bushings C with retaining rings D on all the RH and LH sections.

In this assembly position holes F in pipes 1-3 are not used.

Starting from bracket A for the 16-rake wheel machine and from bracket B for the 14-rake wheel machine, insert pipe 1 (L.2515mm-99.01") into all the brackets B until reaching pipe E already assembled by the manufacturer. Join pipe 1 to pipe E using pin 4, bolts 5 and nuts 6.

Now, starting from bracket A for the 16-rake wheel machine, insert pipe 2 (L.2415mm-95.07") into all the brackets B until reaching pipe 1. Join pipe 2 to pipe 1 using pin 4, bolts 5 and nuts 6.

Now, starting from bracket B for the 14-rake wheel machine, insert pipe 3 (L.1670mm-65.75") into all the brackets B until reaching pipe 1. Join pipe 3 to pipe 1 using pin 4, bolts 5 and nuts 6.

In this step, you will use:

Item 4: 4 pins $\varnothing 25-35 \times 158$ ($\varnothing 1''-1.38'' \times 6.22''$)

Item 5: 8 bolts M8x45 ($0.31'' \times 1.77''$)

Item 6: 8 nuts M8 ($0.31''$)

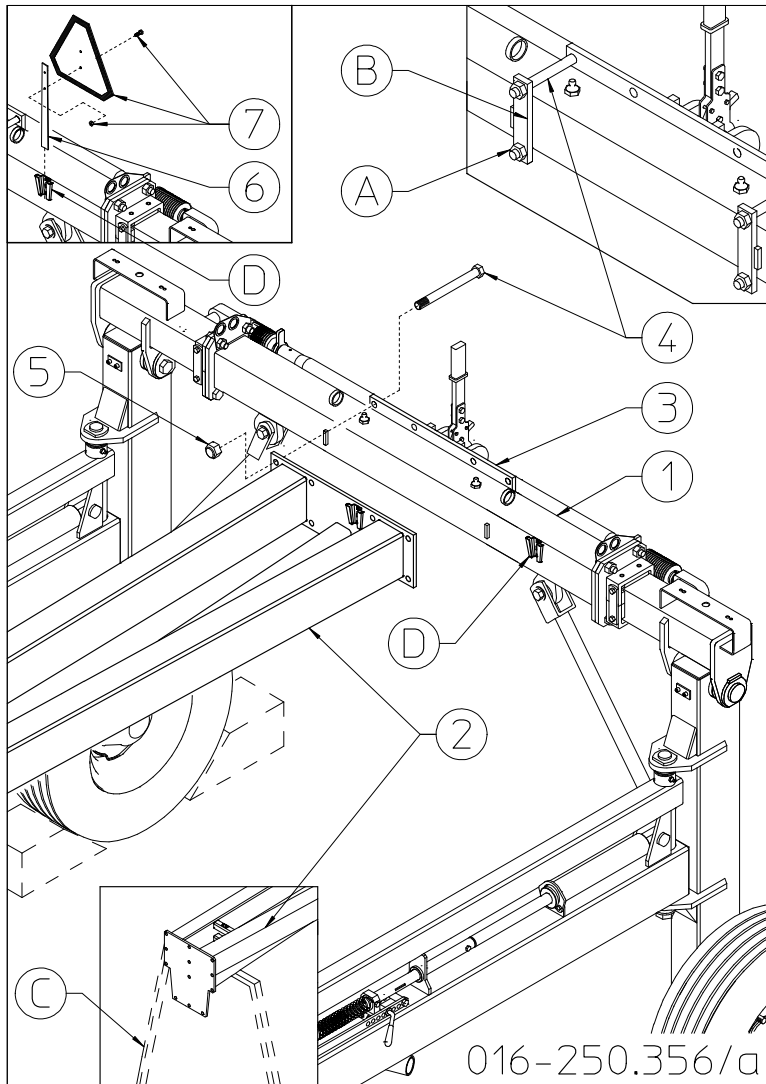

16) DANGER

Carry out this operation very carefully and with suitable lifting equipment because the drawbar 2 is heavy and bulky. Weight 170kg/375lbs. First of all remove the nut A and packing retainer B from the crosspiece assembly 1. The nuts A and packing retainers B will not be reused. To work safely and make the next assembly easier, set the drawbar 27 on a support C.

Attach the drawbar 2 to the counterplate 3 using bolts 4 and nuts 5. Insert support 6 in the seat D. Attach the rear reflector 7 to the support 6.

In this step, you will use:

Item 4: 8 bolts M16x165 (0.63"x6.5")

Item 5: 8 nuts M16 (0.63")

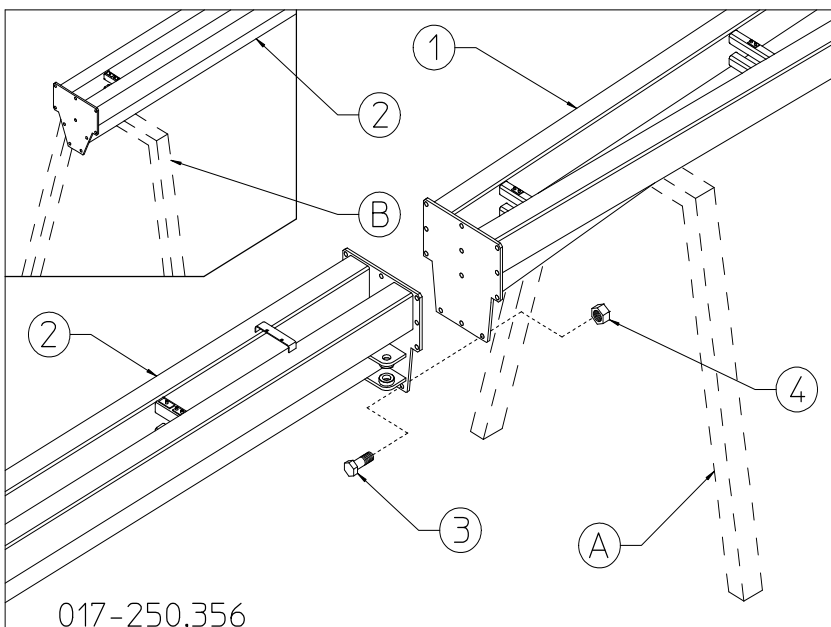

17) DANGER

Carry out this operation very carefully and with suitable lifting equipment because the drawbar 2 is heavy and bulky. Weight 150kg/330lbs plus the preceding drawbar.

To work safely and make the next assembly easier, set the drawbar 2 on a support B.

Attach drawbar 2 to drawbar 1 using bolts 3 and nuts 4.

17) DANGER

In this step, you will use:

Item 3: 12 bolts M16x45 (0.63"x1.77")

Item 4: 12 nuts M16 (0.63")

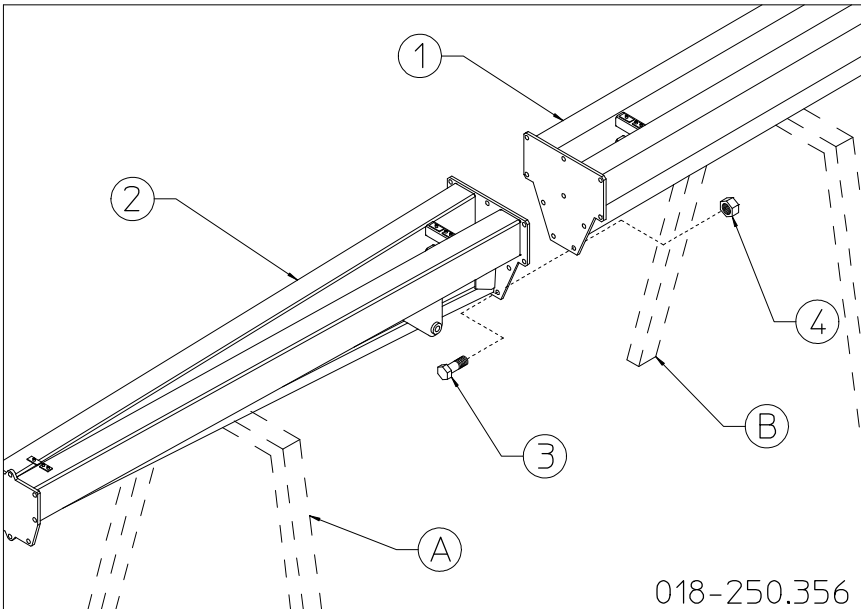

18) DANGER

Carry out this operation very carefully and with suitable lifting equipment because the drawbar 2 is heavy and bulky. Weight 135kg/297lbs plus the preceding drawbar.

To work safely and make the next assembly easier, set the drawbar 2 on a support A.

Attach drawbar 2 to drawbar 1 using bolts 3 and nuts 4.

18) DANGER

In this step, you will use:

Item 3: 10 bolts M16x45 (0.63"x1.77")

Item 4: 10 nuts M16 (0.63")

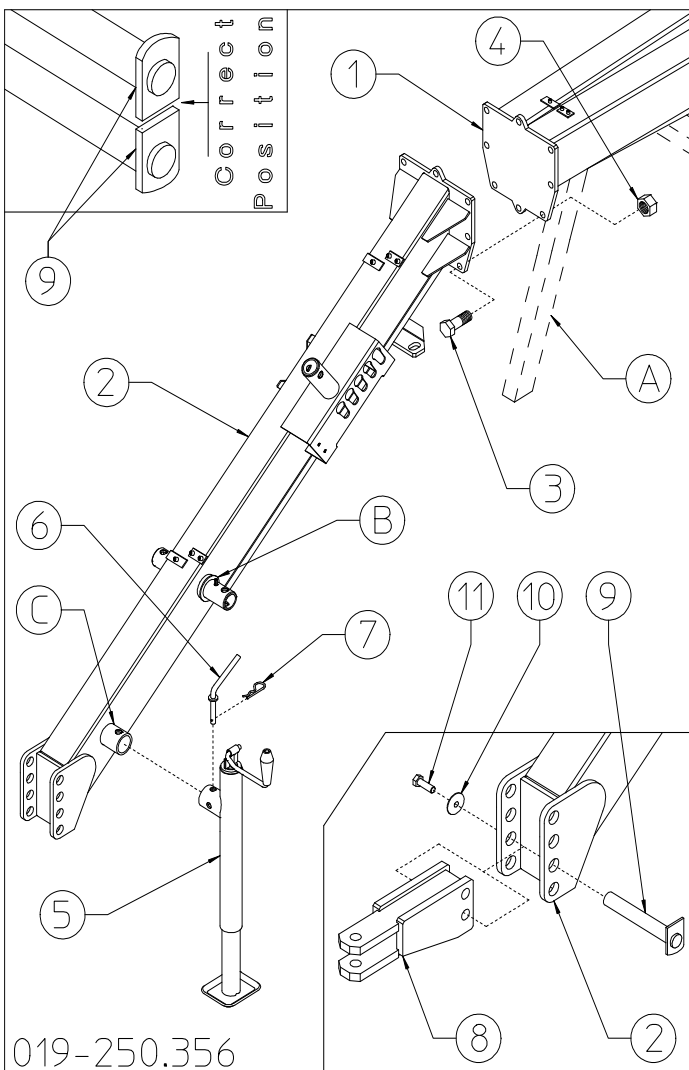

19) DANGER

Carry out this operation very carefully and with suitable lifting equipment because the drawbar 2 is heavy and bulky. Weight 60kg/132lbs plus the preceding drawbars. First of all check to make sure the manufacturer has applied the bushings for the safety arms on seat B.

Now attach drawbar 2 to drawbar 1 using bolts 3 and nuts 4.

Attach the stand 5 to seat C on drawbar 2 using the pin 6 and clip 7.

Note: for the transport position of the stand, see machine use.

Attach the tractor hitch to the two + two central holes of the bracket on drawbar 2 using pins 9, washers 10 and bolts 11.

Note: the correct position of the pins 9 is that shown in the drawing.

In this step, you will use:

Item 3: 8 bolts M16x45 (0.63"x1.77")

Item 4: 8 nuts M16 (0.63")

Item 6: 1 pin $\varnothing 15 \times 78$ ($\varnothing 0.59 \times 3.07$ ")

Item 7: 1 clip $\varnothing 3$ ($\varnothing 0.12$ ")

Item 9: 2 pins $\varnothing 25 \times 124$ (0.98×4.88 ")

Item 10: 2 washers $\varnothing 12 - 36 \times 4$ (0.94 ")

Item 11: 2 bolts M12x20 (0.47×0.79 ")

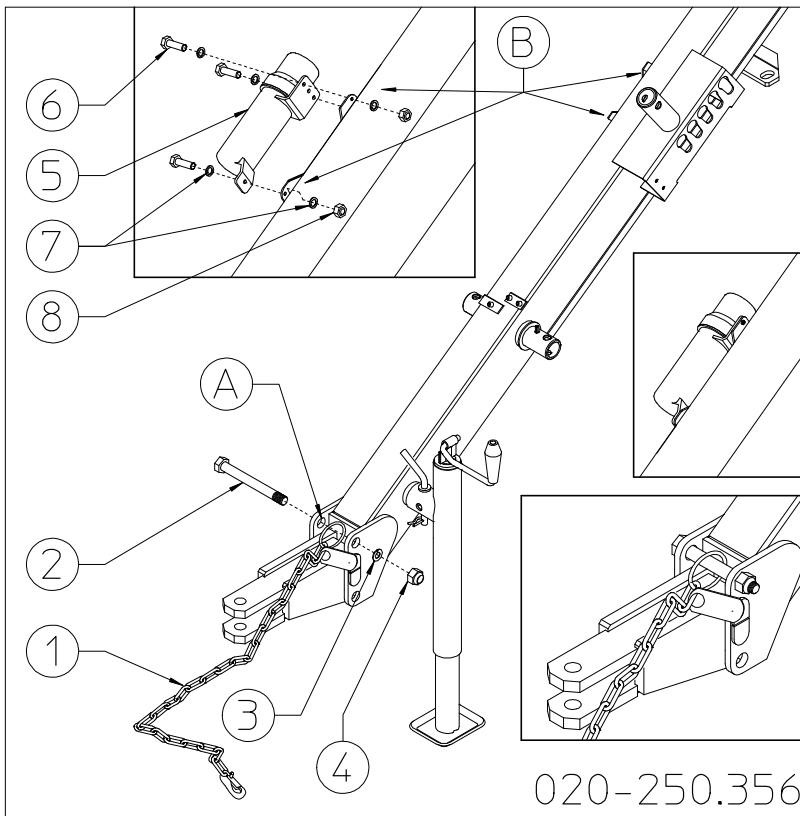

20) DANGER

Attach the safety chain 1 to the holes A in the drawbar using the bolt 2, washer 3 and nut 4.

Attach the canister 5 to seats B on the drawbar using bolts 6, washers 7 and nuts 8.

In this step, you will use:

Item 2: 1 bolt M22x150 (0.87"x5.91")

Item 3: 1 split washer $\varnothing 23$ ($\varnothing 0.91$ "")

Item 4: 1 nut M22 (0.87")

Item 6: 3 bolts M6x20 ($\varnothing 0.24 \times 0.79$ "")

Item 7: 6 washers 6.6-18x2 ($\varnothing 0.26$ "- 0.71 " $\times 0.08$ "")

Item 8: 3 nuts M6 (0.24")

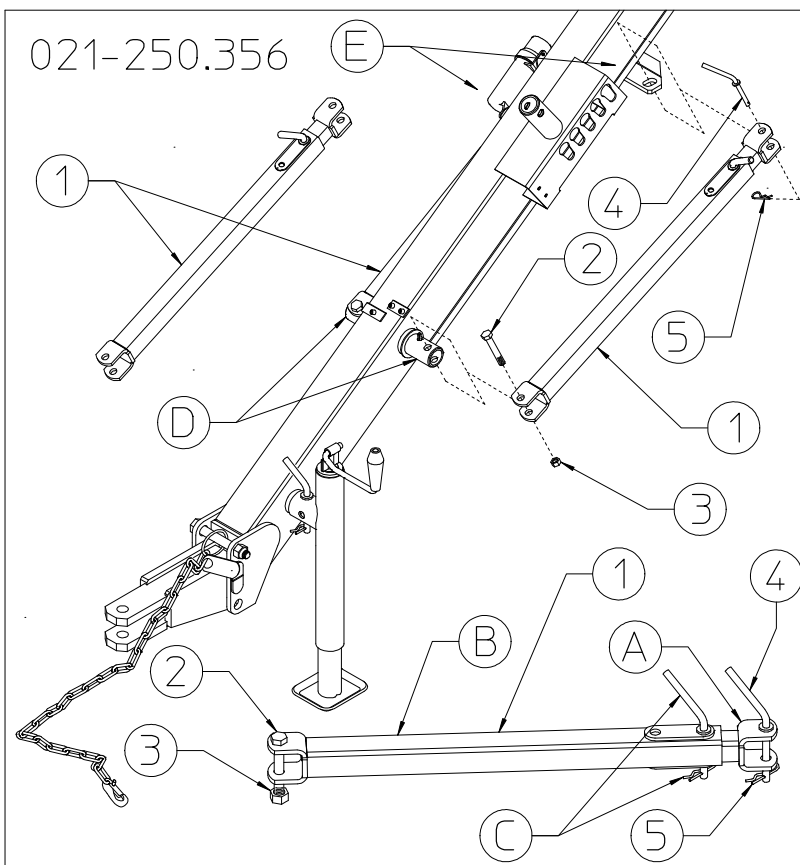

21) DANGER

The safety arms 1 are made up of an inner part A and an outer part B assembled together by the manufacturer using the pin and clip C (same as pins 4 and clips 5). In addition, in the fork of the inner part A you will find preassembled by the manufacturer the pin 4 and clip 5, whereas on the fork of the outer part B you will find preassembled the bolt 2 and nut 3. You will need these to attach the safety arms to seats D-E on the drawbar. Attach safety arm 1 to seat D on the drawbar and fasten in place with bolt 2 and nut 3.

Attach the other end of safety arm 1 to seat E on the drawbar and fasten in place with pin 4 and clip 5.

21) DANGER

In this step, you will use:

Item 2: 2 bolts M16x90 (0.63"x3.54") - Item 3: 2 nuts M16 (0.63")

Item 4: 2 (4) pins $\varnothing 15 \times 78$ ($\varnothing 0.59 \times 3.07$ "") - Item 5: 2 (4) clips $\varnothing 3$ ($\varnothing 0.12$ "")

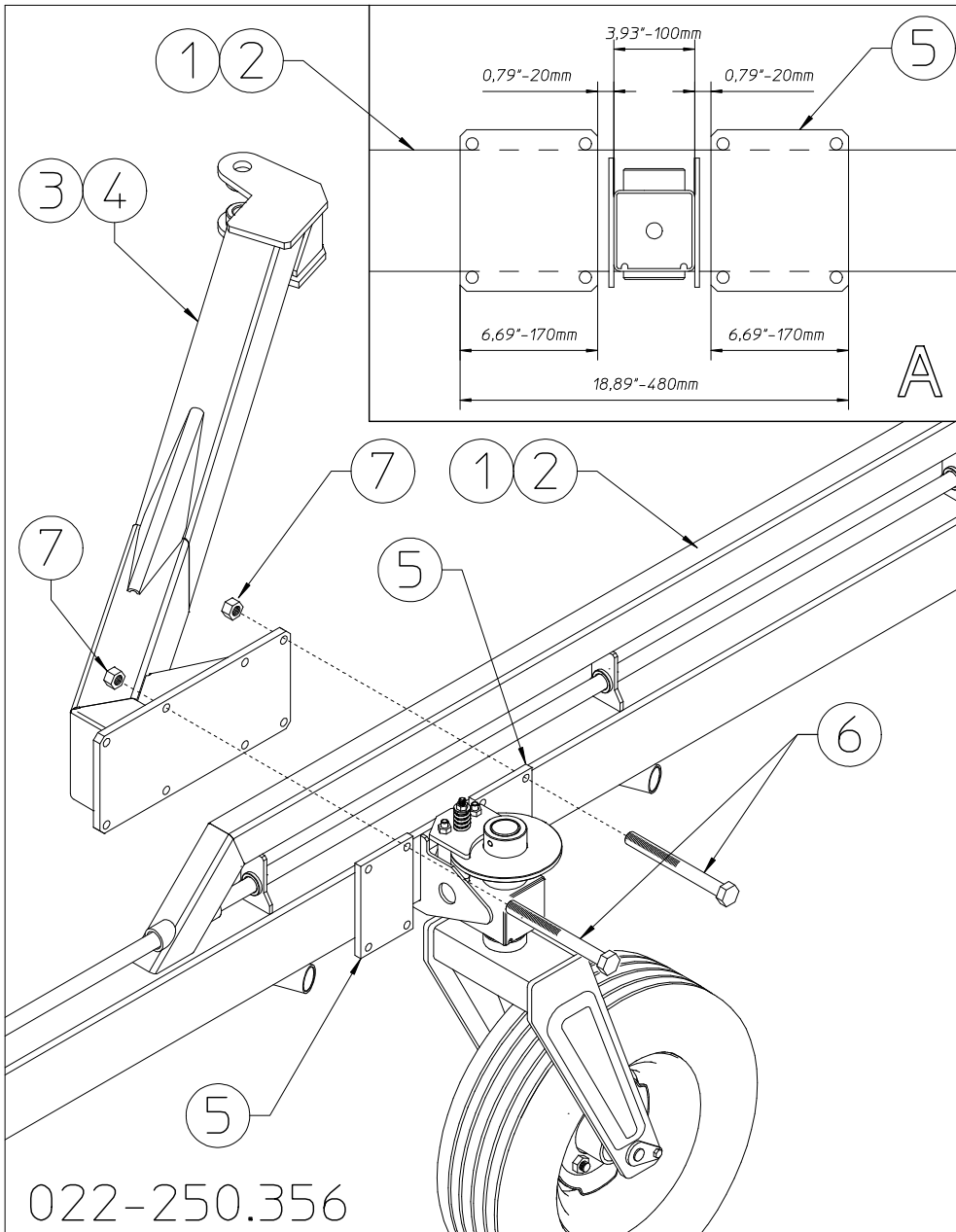

22) DANGER
 Attach the opening arms 3-4 (RH-LH) to sections 1-2 by means of the counterplates 5, bolts 6 and nuts 7. In box A the theoretic measurements are given for the assembly of arms 3-4 and counterplates 5. At this stage do not fully tighten nuts 7, because when the cylinders are attached (see step 27) it may be necessary to move the arms 3-4 and counterplates 5 slightly forward or backward to allow the correct installation of the cylinders.

022-250.356

22) DANGER
 In this step, you will use:
 Item 6: 16 bolts M14x140 (0.55"x5.51") Item 7: 16 nuts M14 (0.55")

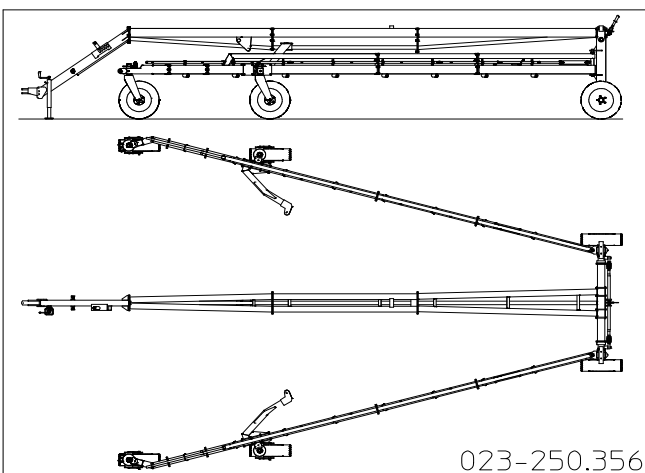

23)
 You have now reached this stage of the assembly. The machine rests on its wheels and the stand and thus has good stability. However, continue the assembly using great caution so as to work safely.

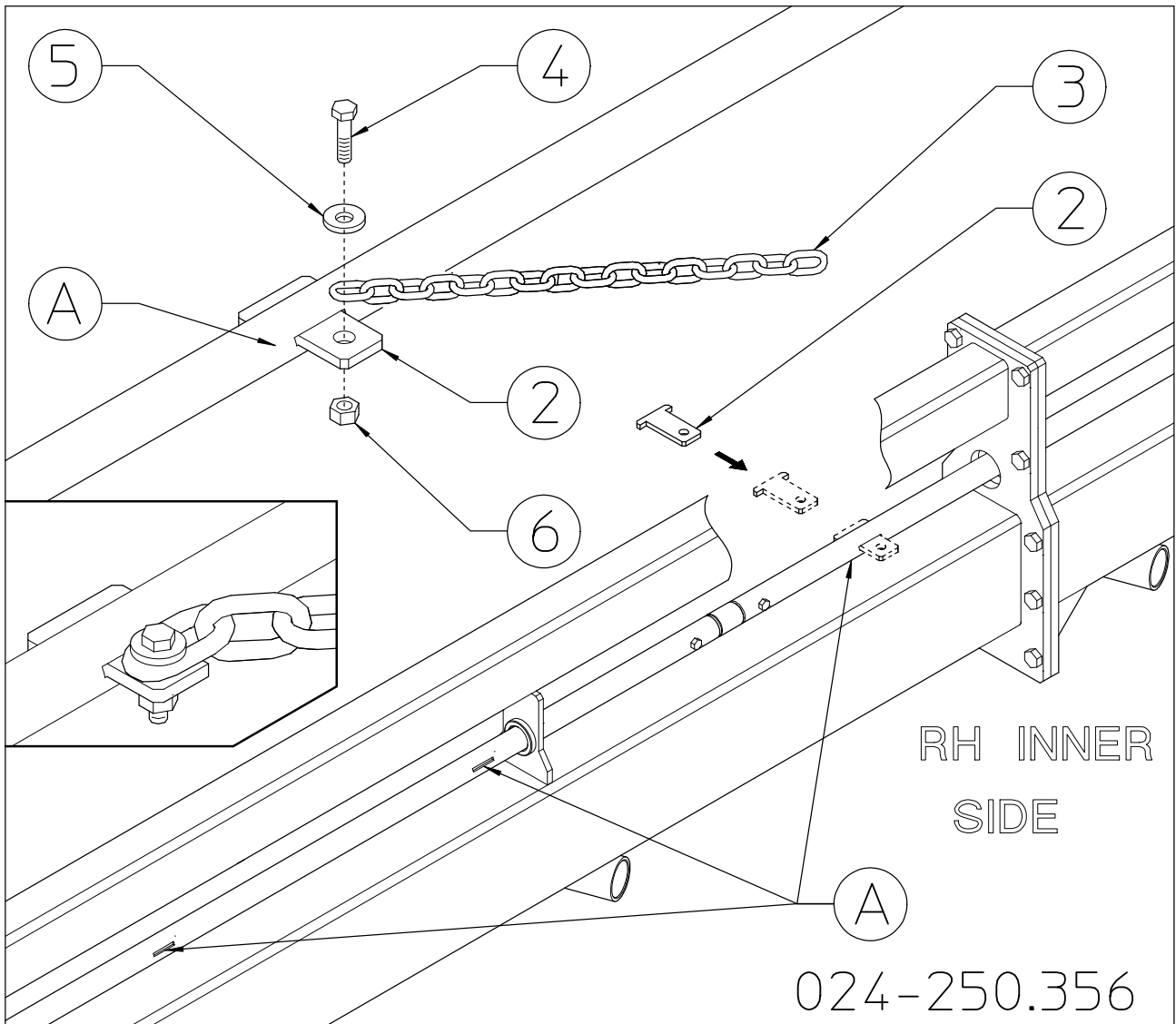

24) DANGER

Insert brackets 2 in the slots A in all the pipes (RH-LH). Attach the chain 3 at all the brackets 2 using the bolt, washer 5 and nut 6.

In this step, you will use:

Item 2: 14-16 chain brackets - Item 3: 14-16 chains, length 820mm (32.3") Item 4: 14-16 bolts M10x25 (0.4"x1") - Item 5: 14-16 washers $\varnothing 11-30 \times 2.5$ ($\varnothing 0.43''-1.18'' \times 0.1''$) - Item 6: 14-16 nuts M10 (0.4")

25) DANGER

(see next page)

Note: for logical sequence purposes we describe the assembly of the rake wheels to the machine frame, but given their bulkiness, if you wish to work with more room available skip ahead to the assembly of the hydraulic system and then come back to the assembly of the rake wheels.

First insert the nylon bushings 1 in the all the seats A in all the sections (RH-LH). Next insert the rake wheel arms 2-3 (RH-LH) in all the seats A in all the sections and secure in place with the washers 4 and spring pins 5. Attach the rake wheels 6-7 (RH-LH) to the arms 2-3 using the bolts 8, washers 9 and nuts 10.

Note: Either 55" or 60" rake wheels can be put on the machine using the same procedures and same components.

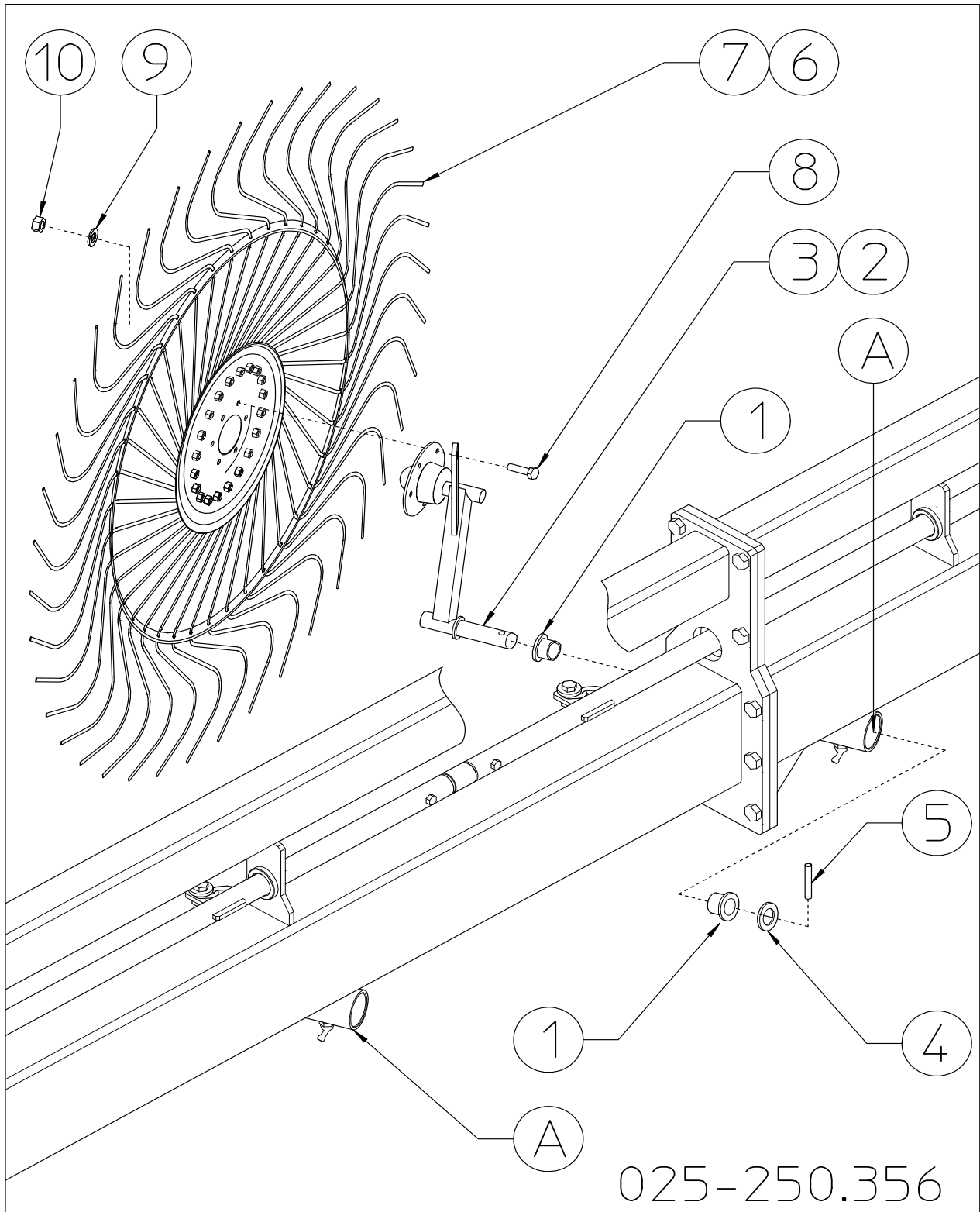

25) DANGER

In this step, you will use:

- Item 1: 28-32 nylon bushings $\text{\textcircled{ø}}35\text{-}42 \times 26$ ($\text{\textcircled{ø}}1.38\text{'-}1.65\text{'}$ x 1')
- Item 4: 14-16 washers $\text{\textcircled{ø}}35\text{-}50 \times 5$ ($\text{\textcircled{ø}}1.38\text{'-}1.97\text{'}$ x 0.19')
- Item 5: 14-16 spring pins $\text{\textcircled{ø}}8 \times 50$ ($\text{\textcircled{ø}}0.31\text{'}$ x 1.97')
- Item 8: 84-96 bolts M10x25 (0.39' x 1')
- Item 9: 84-96 split washers $\text{\textcircled{ø}}10.5\text{-}17 \times 2.5$ ($\text{\textcircled{ø}}0.41\text{'-}0.67\text{'}$ x 0.1')
- Item 10: 84-96 nuts M10 (0.39')

26) DANGER

Hook X on spring 1 is more closed than hook Y. Hook Y (the more open one) should be inserted into hole Z in the lever of arms 2-3 (RH-LH).

First of all pass chain K, which is screwed onto the rake wheel lifting pipes, through the spring 1. Then attach hook Y on spring 1 to hole Z in the lever of arms 2-3. Hook the 9th link of chain K (counting from that screwed onto the rake wheel lifting pipes) to hook X on spring 1. Hook the last link V of chain K onto U-bolt 4, then hook the 24th link of chain K (the 6th from the end), again by means of U-bolt 4, to hole J in the lever of arms 2-3. That described is the standard assembly of chain K to spring 1. For working adjustments, see machine use.

In this step, you will use:

Item 1: 14-16 springs $\emptyset 7-56 \times 276$ ($\emptyset 0.27''-2.2'' \times 10.87''$)

Item 4: 14-16 U-bolts M8 (0.31'')

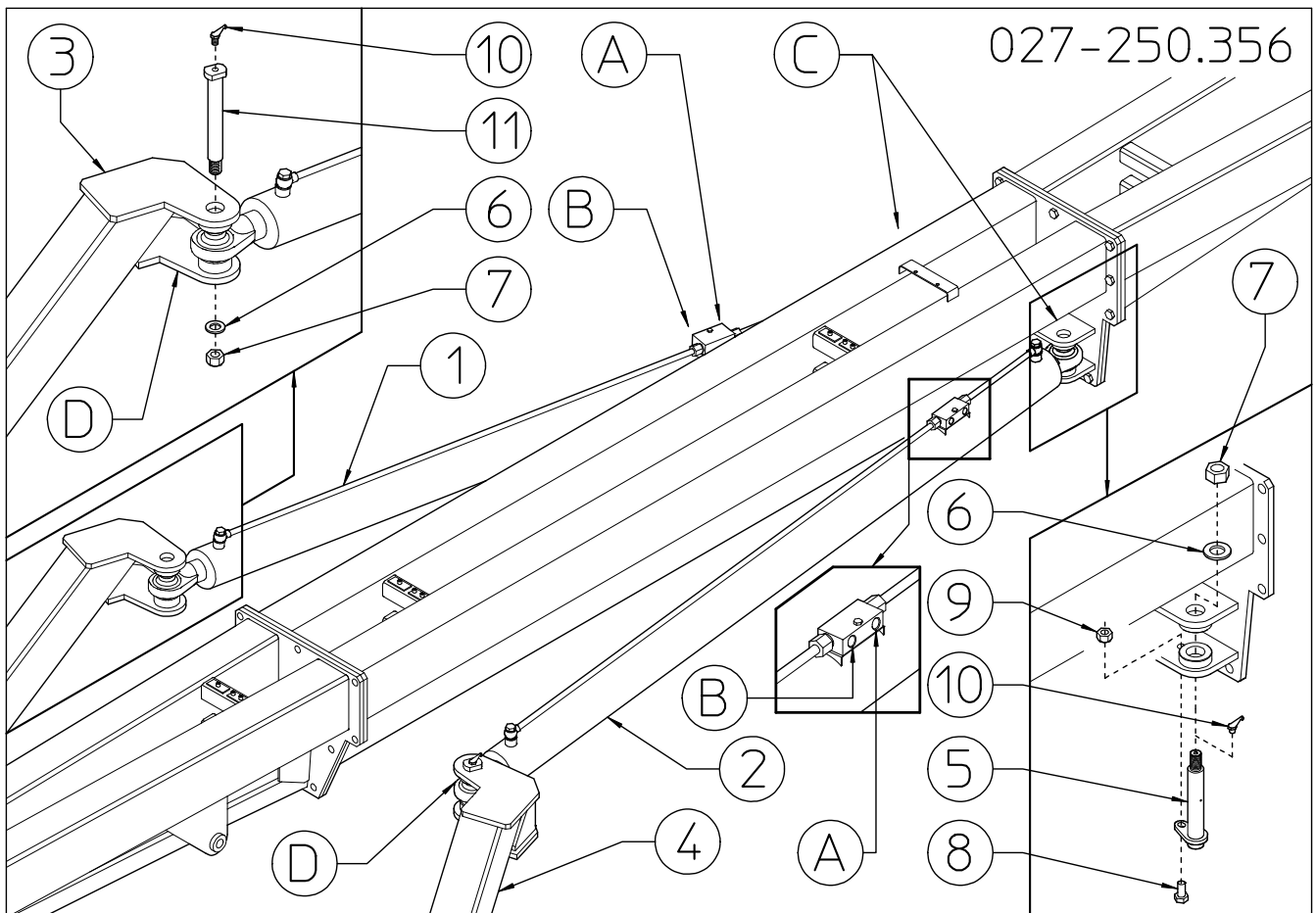

27) DANGER

Note: Spread open the machine in order to have more room to work in.

There are two hydraulic cylinders complete with valves, one set up for the RH side indicated by reference 1 and one for the LH side indicated by reference 2. The assembly is correct when the valve is on the upper part of the cylinder and when holes A-B are facing the outside of the machine. Attach the cylinders 1-2 at brackets C on the drawbar and brackets D on arms 3-4 (RH-LH). Fasten them to brackets C on the drawbar with pins 5, washers 6 and nuts 7. Fasten pins 5 to the drawbar brackets C with bolts 8 and nuts 9. Be very careful while attaching cylinders 1-2 to points C because they are heavy and free on one side, thus potentially hazardous. Now fasten them to brackets D on arms 3-4 with pins 11, washers 6 and nuts 7. Apply grease nipples 10 to pins 5-11. If it is difficult to install cylinders 4 because the arms 3-4 are not in perfect position, see step 22. Once the cylinders are correctly assembled, fully tighten the nuts and bolts from step 22.

In this step, you will use:

- Item 5: 2 pins $\varnothing 30 \times 124$ ($\varnothing 1.18'' \times 4.89''$)
- Item 6: 4 washers $\varnothing 23-50 \times 4$ ($\varnothing 0.91''-1.97'' \times 0.16''$)
- Item 7: 4 nuts M22 (0.87'')
- Item 8: 2 bolts M12x35 (0.47''x1.38'')
- Item 9: 2 nuts M12 (0.47'')
- Item 10: 4 grease nipples M6x45° (0.24'')
- Item 11: 2 pins $\varnothing 30 \times 124$ ($\varnothing 1.18'' \times 4.89''$)

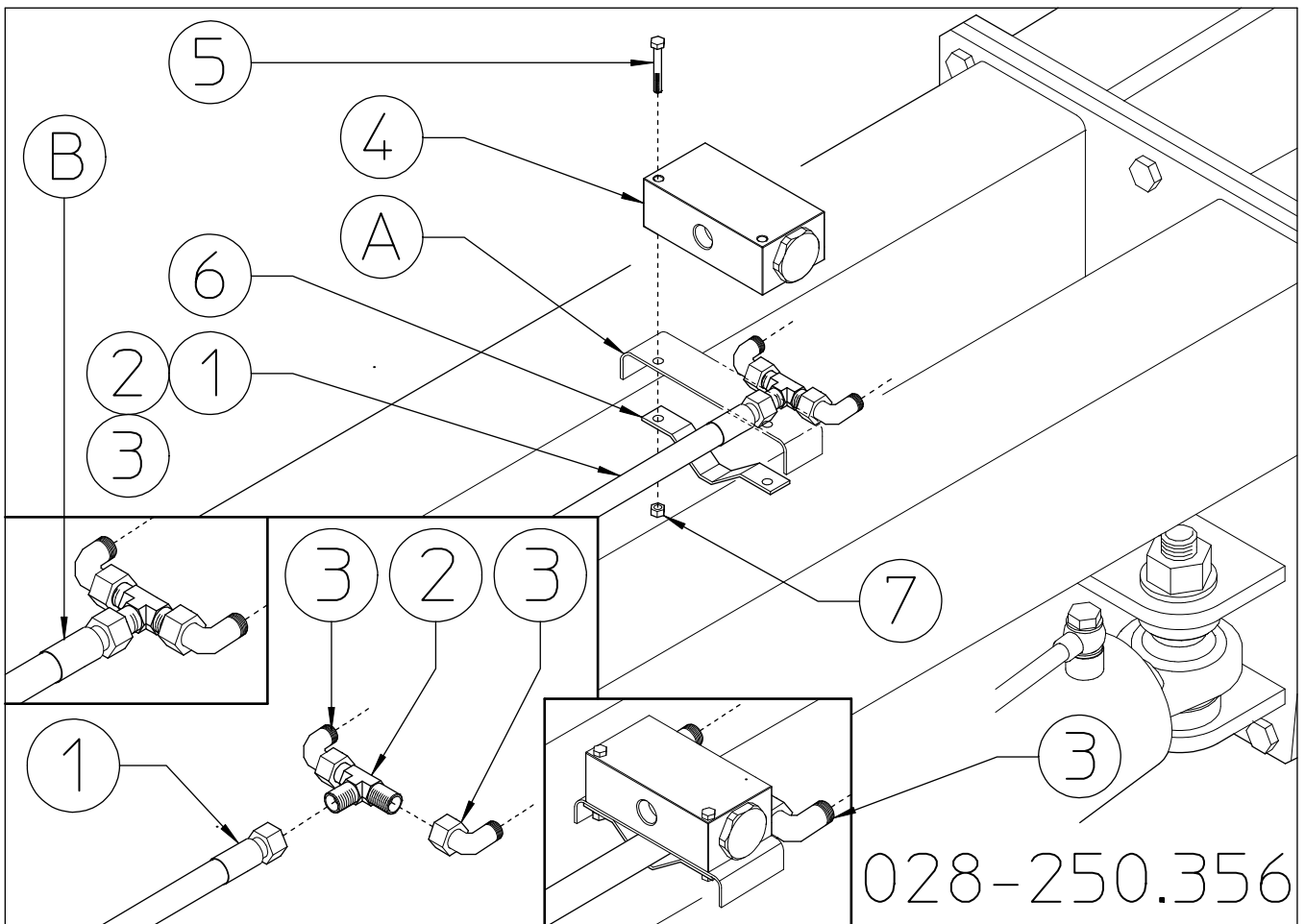

28) DANGER

Extend the hose 1 along the drawbar until the female end is near bracket A. Connect the female end of hose 1 to the T coupling 2. Connect the elbow couplings 3 to the T coupling 2. The assembled hose and couplings unit 1-2-3 are placed underneath bracket A so that the couplings 3 are at the back of it. Now fasten the flow divider 4 and the hose and couplings unit 1-2-3 to bracket A using bolts 5, bracket 6 and nuts 7. Note: bracket 6 must hold hose 1 on the rubber part of the hose just behind the steel bushing B at the end of the hose.

Hose 1 will also be in the following steps.

In this step, you will use:

- Item 1: 1 hose, $\frac{1}{2}$ " , length 7850mm (309.1")
- Item 2: 1 male T coupling, $\frac{3}{4}$ " , JIC 37°
- Item 3: 2 male-female elbow couplings, $\frac{3}{4}$ " , JIC 37°
- Item 4: 1 flow divider
- Item 5: 2 bolts M6x60 (0.47"-2.36")
- Item 6: 1 hose support
- Item 7: 2 nuts M6 (0.24")

029-250.356

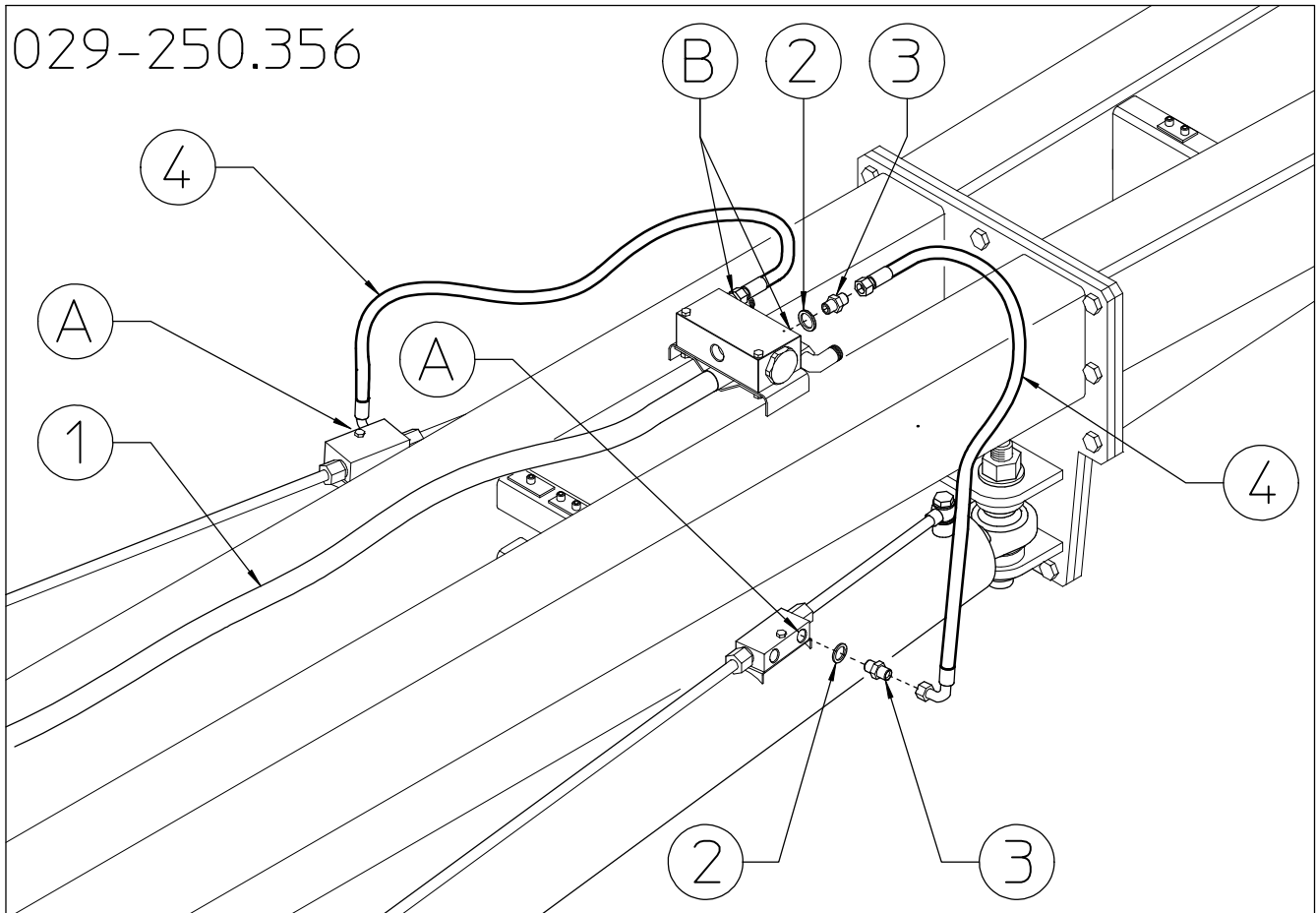

29) DANGER

Apply washers 2 and nipples 3 to holes A on the check valves of the RH and LH cylinders. Apply washers 2 and nipples 3 to holes B on the flow divider. Connect the curved end of hoses 4 to nipples 3 on the cylinder check valves. Connect the other end of hose 4 to nipples 3 on the flow divider without fastening completely. Before fully fastening hoses 4, make sure that the line of each hose from one end to the other is not twisted and/or does not have sharp bends or kinks that cause it to be crushed or to have an unpleasant appearance.

In this step, you will use:

Item 1: see preceding step

Item 2: 4 washers $\varnothing 3/8''$

Item 3: 4 nipples $3/8''-3/4''$ JIC

Item 4: 2 hoses, $3/8''$, length 750mm ($3/8'' \times 29.53''$)

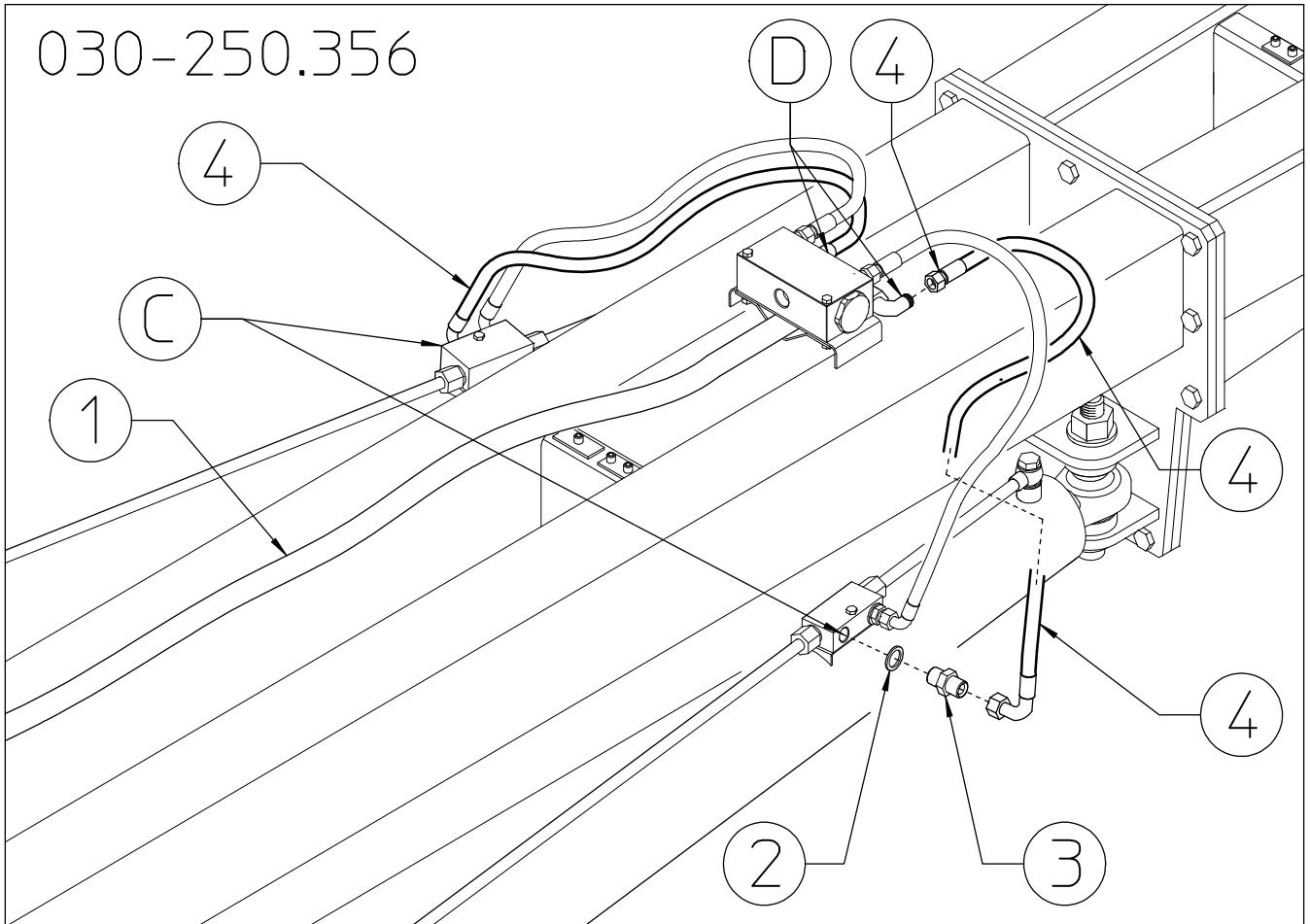

30) DANGER

Apply washers 2 and nipples 3 to holes C on the check valves of the RH and LH cylinders. Connect the curved end of hoses 4 to nipples 3 on the cylinder check valves without tightening completely. Connect the other end of hose 4 to couplings D located underneath the flow divider bracket without fastening completely. Note: Before fully fastening hoses 4, make sure that the line of each hose from one end to the other is not twisted and/or does not have sharp bends or kinks that cause it to be crushed or to have an unpleasant appearance.

In this step, you will use:

Item 1: see preceding step

Item 2: 2 washers $\varnothing 3/8''$

Item 3: 2 nipples $3/8''-3/4''$ JIC

Item 4: 2 hoses, $3/8''$, length 750mm ($3/8'' \times 29.53''$)

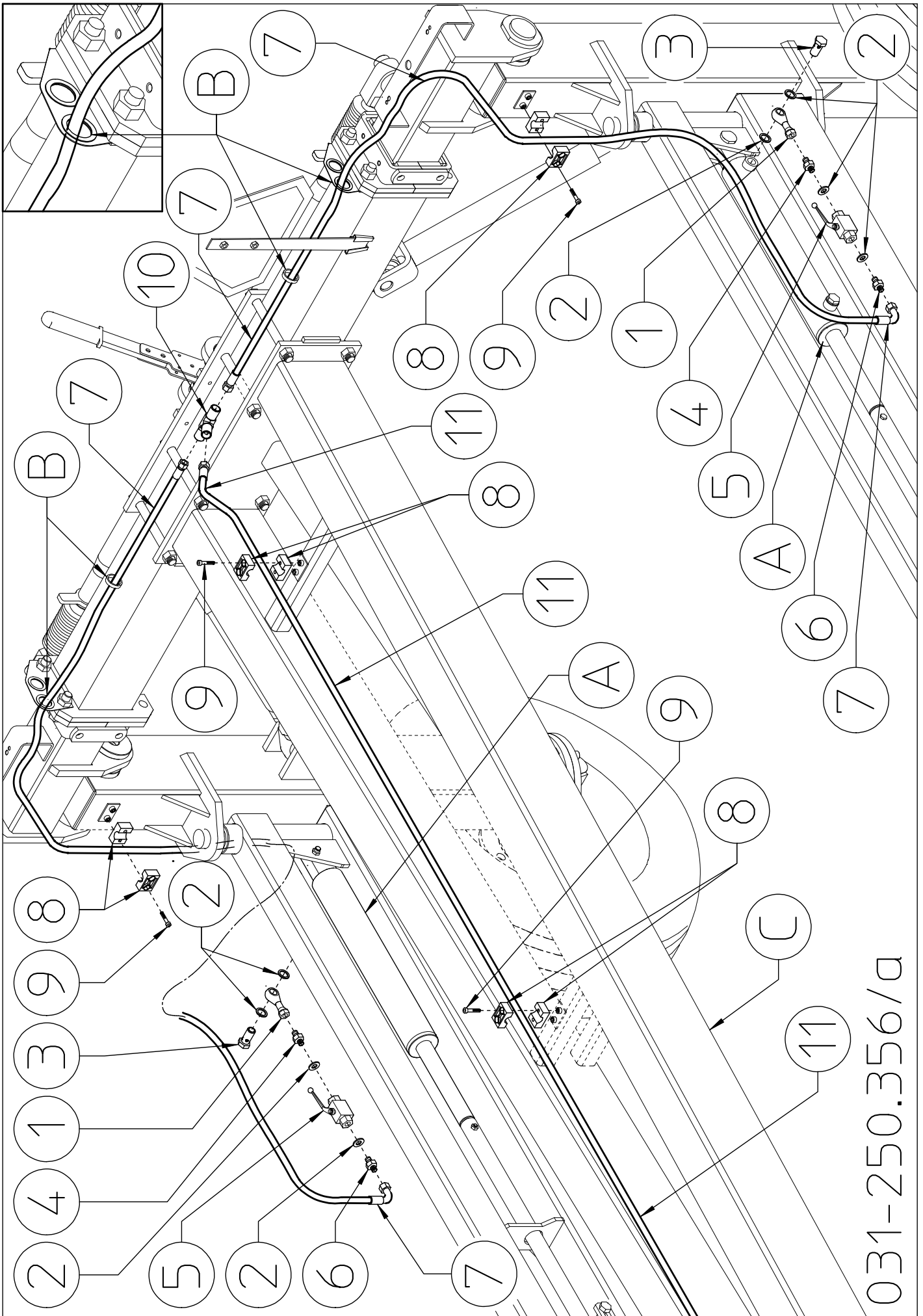

031-250.356/a

31) DANGER (see drawing on preceding page)

Connect coupling 1 to cylinders A using washers 2 and bolts 3. Apply nipple 4 to coupling 1. Apply washer 2 and valve 5 to nipple 4. Apply washer 2 and nipple 6 to valve 5. Insert hoses 7 in the guide rings B so that the one end of the hoses goes to the center of the machine and the other end near the nipples screwed onto valves 5. Now connect hoses 7 to nipples 6 without fastening completely. Secure the hoses 7 using collars 8 and screws 9. Join the ends of the hoses 7 to the T coupling at the center of the machine without fastening completely.

Bring the female end of hose 11 near to the T coupling 10 and extend it along drawbar C. Connect the female end of hose 11 to the T coupling 10 without fastening completely. Note: Before fully fastening all the hoses, make sure that the line of the hose from one end to the other is not twisted and/or does not have sharp bends or kinks that cause it to be crushed or to have an unpleasant appearance.

Now secure hose 11 using collars 8 and screws 9. Hose 11 will also be in the following steps.

In this step, you will use:

Item 1: 2 couplings eye 3/8" female 3/8"

Item 2: 8 washers \varnothing 3/8"

Item 3: 2 screw-type couplings 3/8"

Item 4: 2 nipples 3/8"-3/8"

Item 5: 2 valves 3/8"

Item 6: 2 nipples 3/8"-3/4" JIC 37°

Item 7: 2 hoses, 3/8", length 1840 mm (3/8"x72.44")

Item 8: 8 collars \varnothing 18 (\varnothing 0.71")

Item 9: 8 cheese head screws M6x25 (0.24"x1")

Item 10: 1 male T coupling, 3/8" JIC 37°

Item 11: 1 hose, 3/8", length 6700mm (3/8"x263.78")

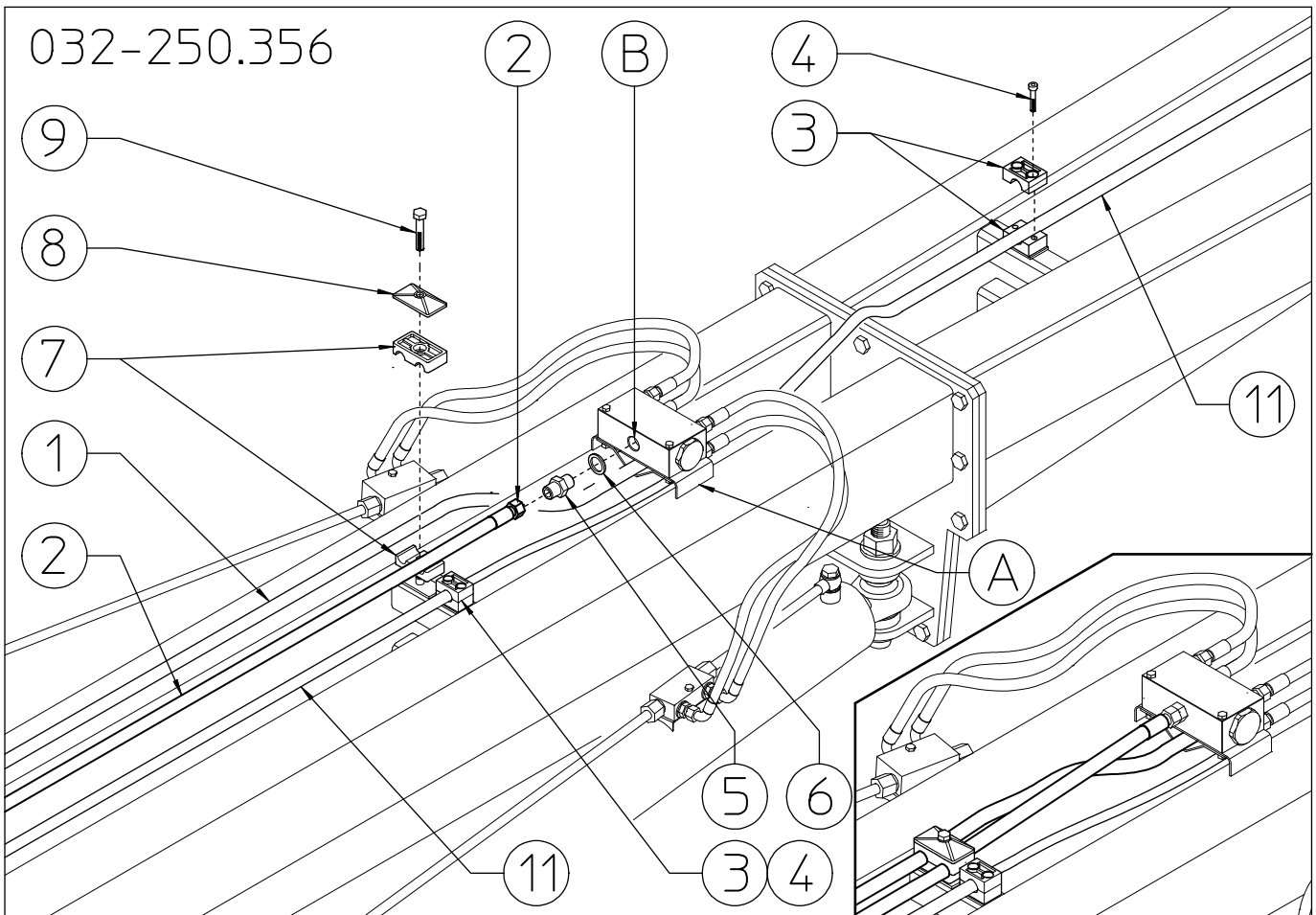

32) DANGER

Send hose 11 under bracket A and continue to secure it with collars 3 and screws 4. Apply washer 6 and nipple 5 to hole B on the flow divider. Bring the female end of hose 2 near the nipple and extend it along drawbar C toward the front of the machine parallel to hose 1 already assembled. Connect the female end of hose 2 to the nipple 5 without fastening completely.

Note: Before fully fastening all the hoses, make sure that the line of the hose from one end to the other is not twisted and/or does not have sharp bends or kinks that cause it to be crushed or to have an unpleasant appearance.

Now secure hoses 1-2 using collars 7, clamp 8 and bolts 9. Hoses 1-2-11 will also be in the following steps.

In this step, you will use:

- Item 1: see preceding step
- Item 2: 1 hose, 1/2", length 7750mm (305.12")
- Item 3: 4 collars $\varnothing 18$ ($\varnothing 0.71$ ")
- Item 4: 4 cheese head screws M6x25 (0.24"x1"
- Item 5: 1 nipple 3/8"-7/8" JIC
- Item 6: 1 washer $\varnothing 3/8$ "
- Item 7: 2 double collars $\varnothing 22$ ($\varnothing 0.87$ ")
- Item 8: 1 clamp $\varnothing 22$ ($\varnothing 0.87$ ")
- Item 9: 1 bolt M8x45 (0.31"x1.77")
- Item 11: see preceding step

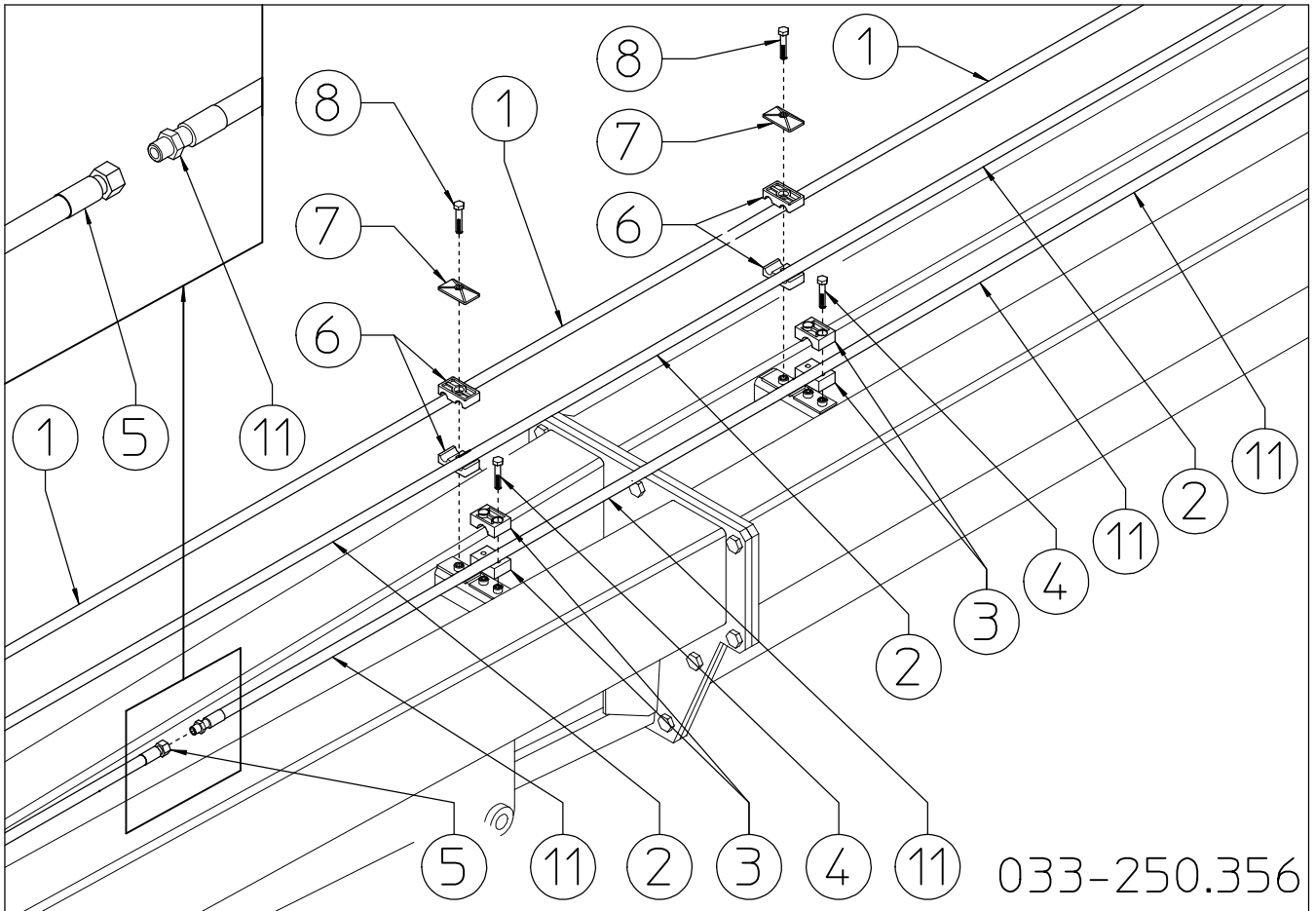

33) DANGER

Continue to secure hose 11 with collars 3 and screws 4. Continue to secure hoses 1-2 with collars 6, clamps 7 and bolts 8.

Bring the female end of hose 5 near the male end of hose 11 and extend it along drawbar C toward the front of the machine parallel to hoses 1-2 already assembled. Connect the female end of hose 5 to hose 11.

Hoses 1-2-5 will also be in the following steps.

In this step, you will use:

- Item 1-2-11: see preceding step
- Item 3: 4 collars $\varnothing 18$ ($\varnothing 0.71''$)
- Item 4: 4 cheese head screws M6x25 ($0.24'' \times 1''$)
- Item 5: 1 hose, $3/8''$, length 4550mm ($3/8'' \times 179.13''$)
- Item 6: 4 double collars $\varnothing 22$ ($\varnothing 0.87''$)
- Item 7: 2 clamps $\varnothing 22$ ($\varnothing 0.87''$)
- Item 8: 2 bolts M8x45 ($0.31'' \times 1.77''$)

034-250.356

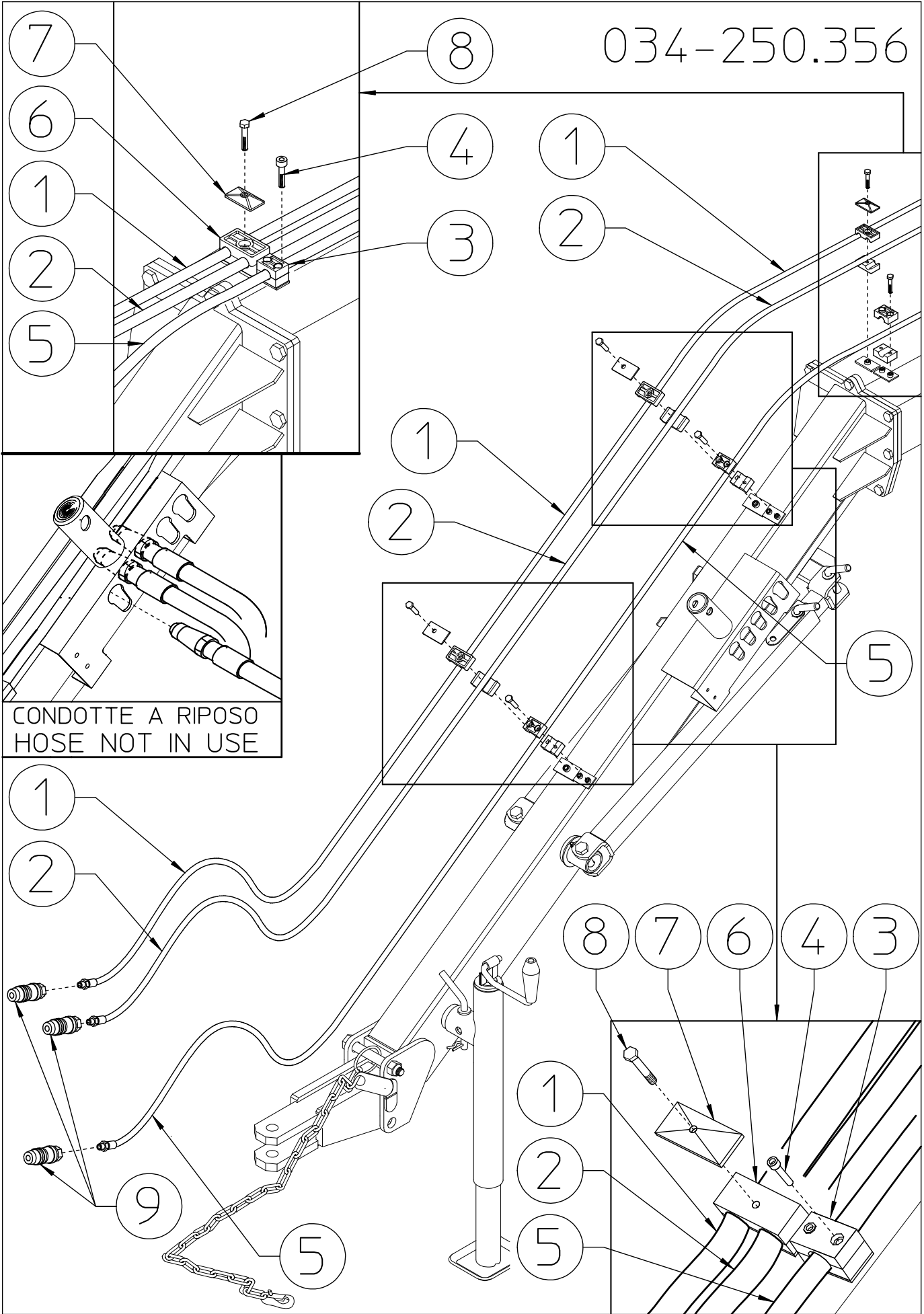

CONDOTTE A RIPOSO
HOSE NOT IN USE

34) DANGER

Continue to secure hose 5 with collars 3 and screws 4. Continue to secure hoses 1-2 with collars 6, clamps 7 and bolts 8.

Connect the quick-release couplings 9 to the male ends of hoses 1-2-5.

Note: to prevent oil leakage is recommended to apply Loctite on the couplings 9 and on the hoses 1-2-5

In this step, you will use:

Item 1,2,5: see preceding step

Item 3: 6 collars $\varnothing 18$ ($\varnothing 0.71''$)

Item 4: 6 cheese head screws M6x25 (0.24"x1")

Item 6: 6 double collars $\varnothing 22$ ($\varnothing 0.87''$)

Item 7: 3 clamps for collars $\varnothing 22$ ($\varnothing 0.87''$)

Item 8: 3 bolts M8x45 (0.31"x1.77")

Item 9: 3 male quick-release couplings 1/2"

Note: If the rake wheels have not been assembled, return to steps 25-26; otherwise, the assembly is completed.

035-250.356

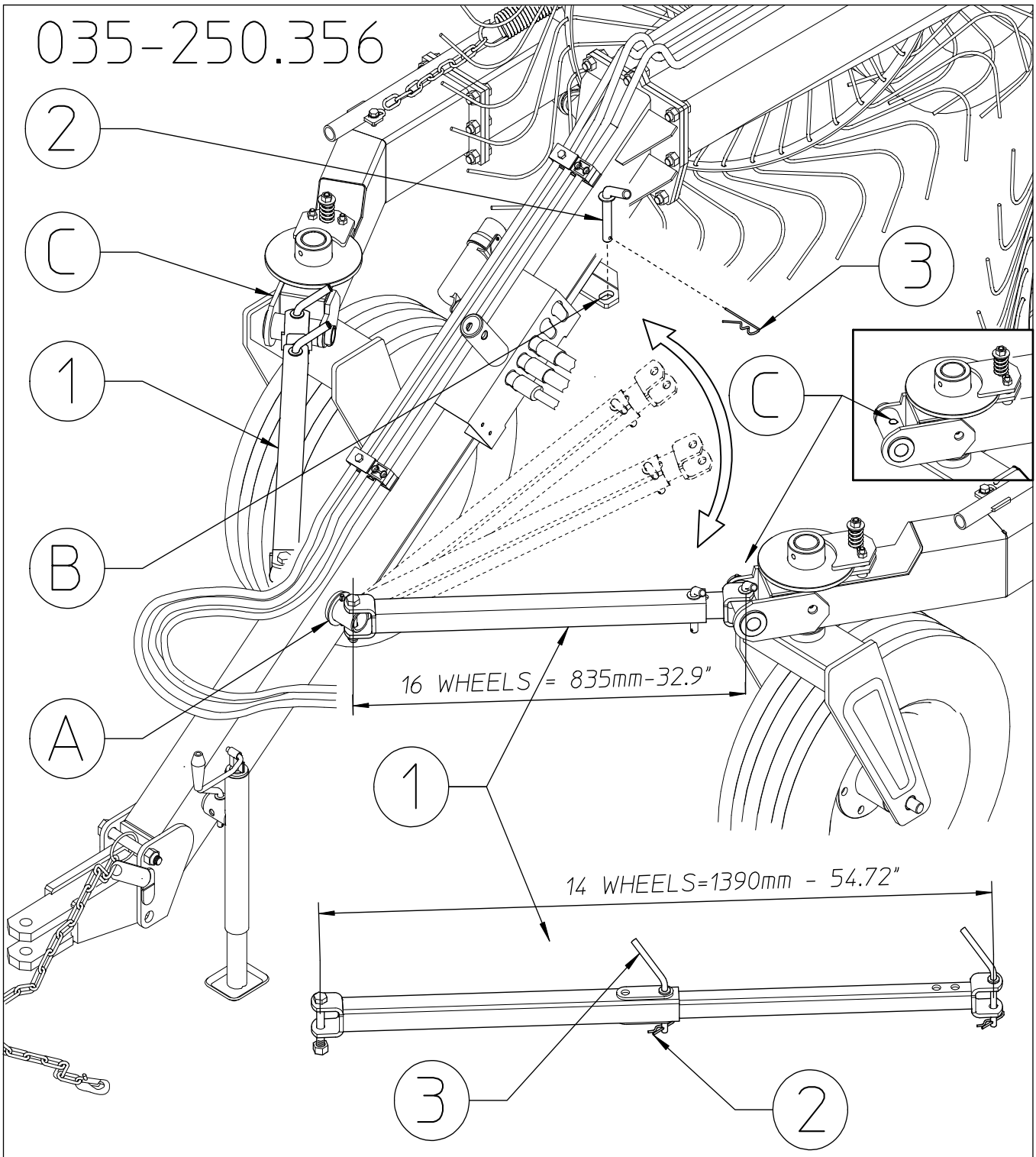

35) DANGER

The assembly is now completed. The machine is ready to be lubricated and then used. If for lubricating or for other reasons the machine must be moved, the safety arms must be rotated from the working position A-B to the transport position A-C. To do this you must remove the pin 2 and clip 3 from position B, rotate the arm until it reaches position C, and then fasten it again with pin 2 and clip 3.

If it is a 14-rake wheel machine, remove the pin 2 and clip 3 that fasten the outer part of the arm to the inner part, then slide the inner part until it reaches the length indicated 1390mm/54.72” and fasten again with pin 2 and clip 3. At this point fasten arm 1 to point C with the pin 2 and clip 3. (If any adjustments in length are necessary, there are two holes available.)

The instructions for maintenance in the following table must be carried out, besides this first time, according to the time schedule given, throughout the entire life of the machine.

See also the sections on preparation and use of the machine.

MAINTENANCE POINTS AND INSTRUCTIONS

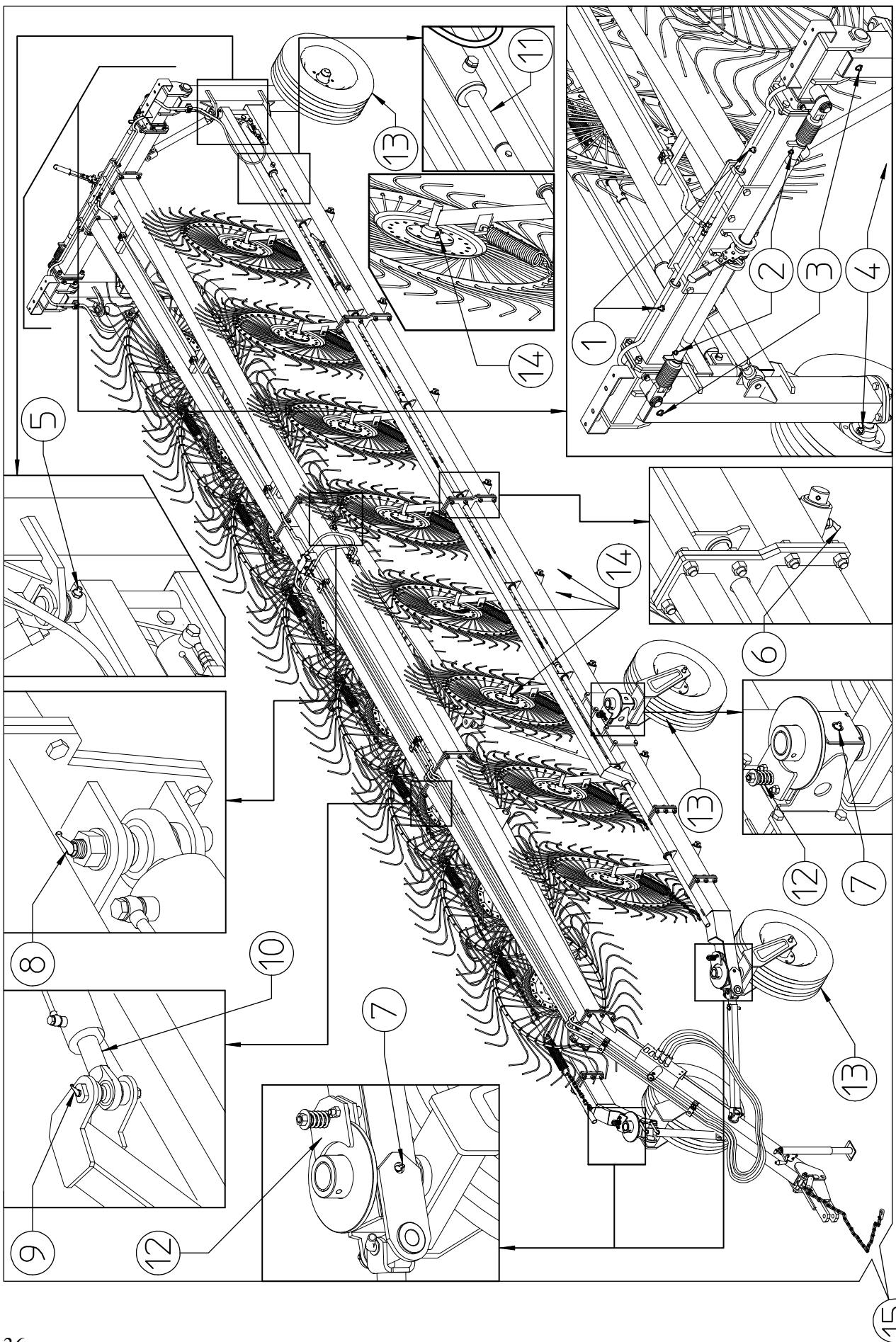

250.362/a

MAINTENANCE POINTS AND INSTRUCTIONS

Pos.	Qty.	Description	Operation	Every x hours
1	2	Rear crosspiece	Lubricate	50 (A)
2	2	Opening tie rod	Lubricate	50 (A)
3	2	Vertical support	Lubricate	25
4	2	Rear wheel hub	Lubricate	16
5	2	Section joint pin	Lubricate	50 (A)
6	14-16	Rake wheel arm joint	Lubricate	25
7	4	Pirouetting wheel support	Lubricate	25
8	2	Rear cylinder pin	Lubricate	25
9	2	Front cylinder pin	Lubricate	25
10	2	Opening cylinder shaft	Clean-brush grease	B
11	2	Rake wheel lifting cylinder shaft	Clean-brush grease	B
12	4	Pirouetting wheel brake	Check effectiveness	C
13	6	Tires	Check pressure	D
14	14-16	Rake wheel hub	Lubricate	25
15	*	Do the first general check after 8 working hours. Check carefully the stability of the coupling of nuts and bolts, pins, clips, tire pressure, etc. After this do a check every 50 working hours.		

Grease type: NLGI 1

A: Normally it is sufficient to lubricate every 50 hours, but to make the machine operate more smoothly it is a good practice to grease the crosspiece, the tie rod and the crank every time the machine is used after a long period of inactivity.

B: Exposure to atmospheric agents subjects these parts to rusting, therefore each time the machine is inactive for long periods (especially during the winter) brush the cylinder shafts with grease. When possible keep the cylinders closed so that a minimum amount of shaft is outside the cylinder barrel.

C: The wheels must pirouette freely, but without becoming uncontrollable. Check the wear of the disks each season. (To adjust the brake, see machine use.)

D: Check the tire pressure each time the machine is used, especially after long periods of inactivity. Bring the tires to the right pressure if necessary, according to the indication on the tires.

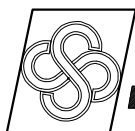

sitrex AGRICULTURAL MACHINERY [®] SpA .

Zona Industriale-Viale Grecia, 8
06018 TRESTINA-(Perugia)-ITALY
Tel. +39.075.8540021-Telefax +39.075.8540523
e-mail: sitrex@sitrex.it www.sitrex.com

