



MidCap Rotary Rake

Illustrated Parts Breakdown

Page 1	Main Frame
Page 2	Transport Wheel Assembly
Page 3	Lift Arm Assembly
Page 4	Main Beam Assembly
Page 5	Rear Beam Assembly
Page 6	Front Beam Extensions
Page 7	Wheel Arm Spring Assembly
Page 8	Wheel Arm Hub Assembly
Page 9	Rake Wheel Assembly
Page 10	12 Wheel Beam Extension,-Right
Page 11	12 Wheel Beam Extension,-Left
Page 12	10 Wheel Beam Extension,-Right
Page 13	10 Wheel Beam Extension,-Left
Page 14	Beam Lift Hydraulics
Page 15	Hydraulic Wheel Beam Assembly
Page 16	Hydraulic Wheel Beam Cylinder
Page 17	Kicker Wheel Assembly
Page 18	Kicker Wheel Hydraulics
Page 19	Manifold Fittings

Main Frame

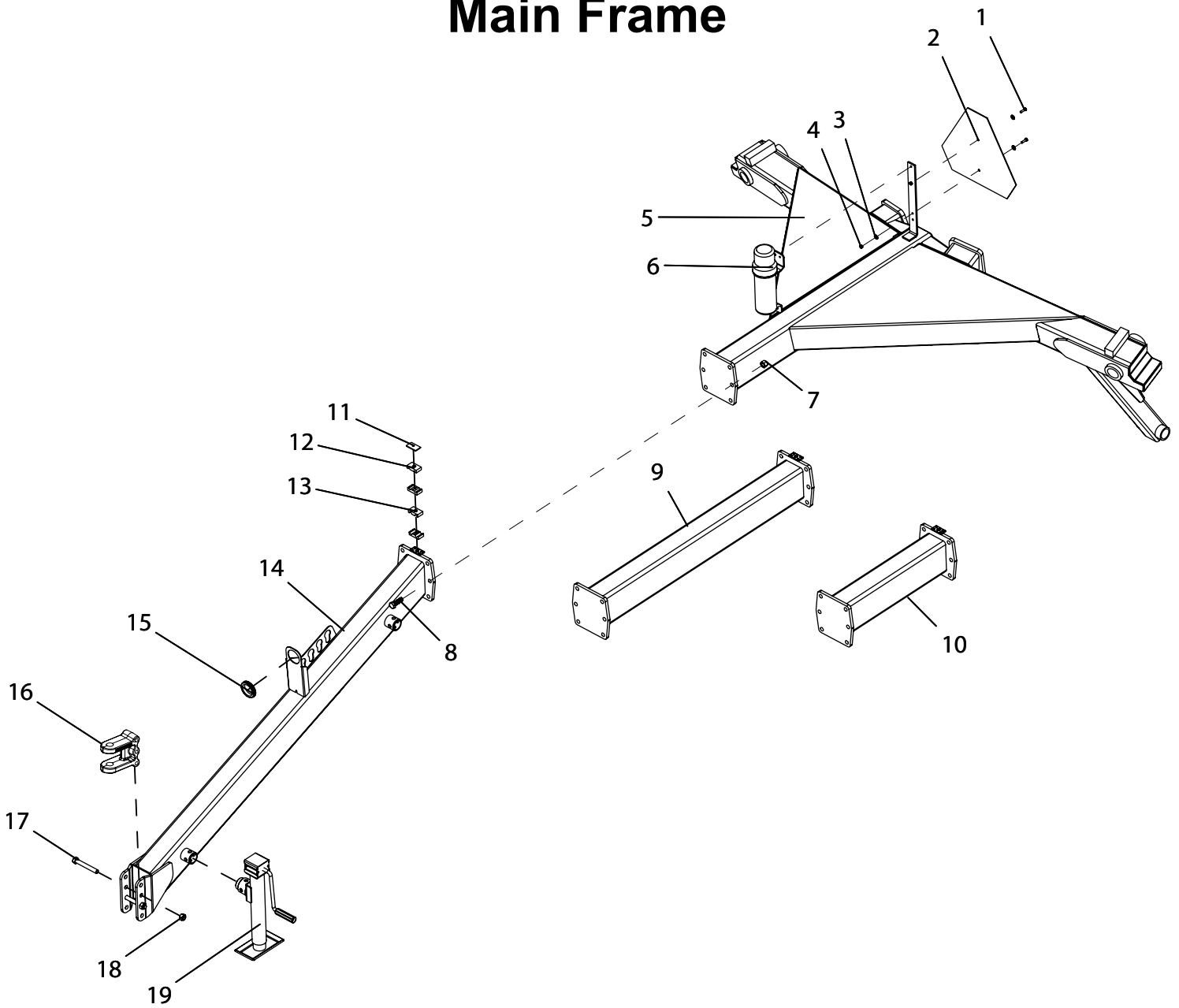

ID	Description	Part #
1	1/4-20 x 1 HH Bolt, Gr5	100148
2	Fanny Flag	507166
3	1/4 USS Flat Washer	001020
4	1/4-20 Hex Nut Zinc	000900
5	TR Main Frame	510505
6	Ops Manual Cylinder	503050
7	5/8-11 Top Lock Nut, Zinc	000973
8	5/8-11 x 2 Hex Head Bolt	000615
9	12 Wheel Ext. Tongue	510572
10	10 Wheel Ext. Tongue	510601

ID	Description	Part #
11	Hose Clamp Top Plate	510630
12	1/4" Clamp Block	510632
13	3/8 Clamp Block	507300
14	Front Tongue Section	510530
15	Grommet	510621
16	2 hole Clevis	507018
17	5/8-11 x 4.5 HH Bolt Zinc	000645
18	5/8-11 Stover Locknut	900145
19	2K Side Wind Jack	903317

Transport Wheel Assembly

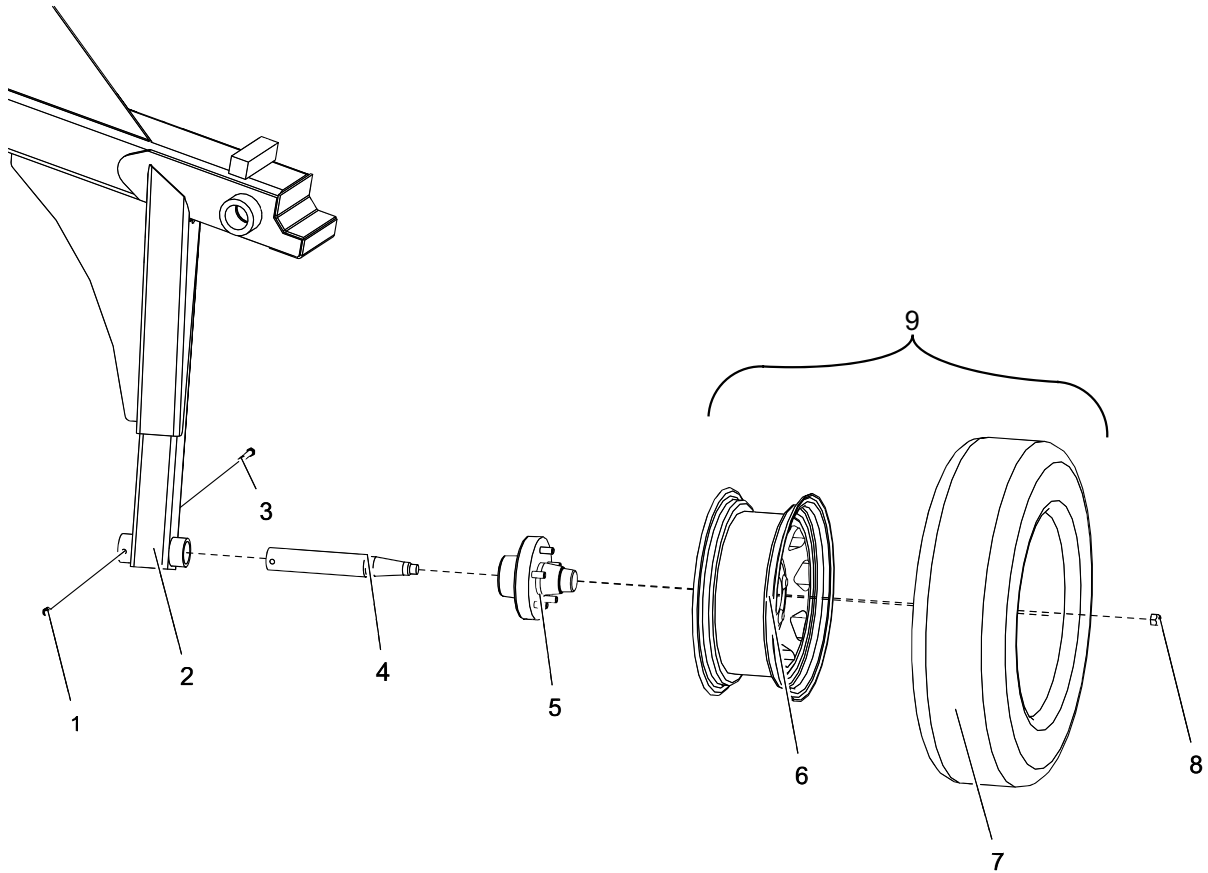

ID	Description	Part #	Qty
1	3/8"-16 Nylon Lock Nut	003000	1
2	TR Main Frame	510505	1
3	3/8"-16 x 3" Hex Head Bolt	000307	1
4	1-3/4" x 12" Spindle	508027	1
5	545 Hub Assembly	508026	1
6	Rim, 15 x 6-6 White Spoke	102186	1
7	Tire, 205/75 D15	100723	1
8	1/2" Cone Wheel Nut	101458	1
9	Tire and Rim, Mounted	100284	1

Lift Arm Assembly

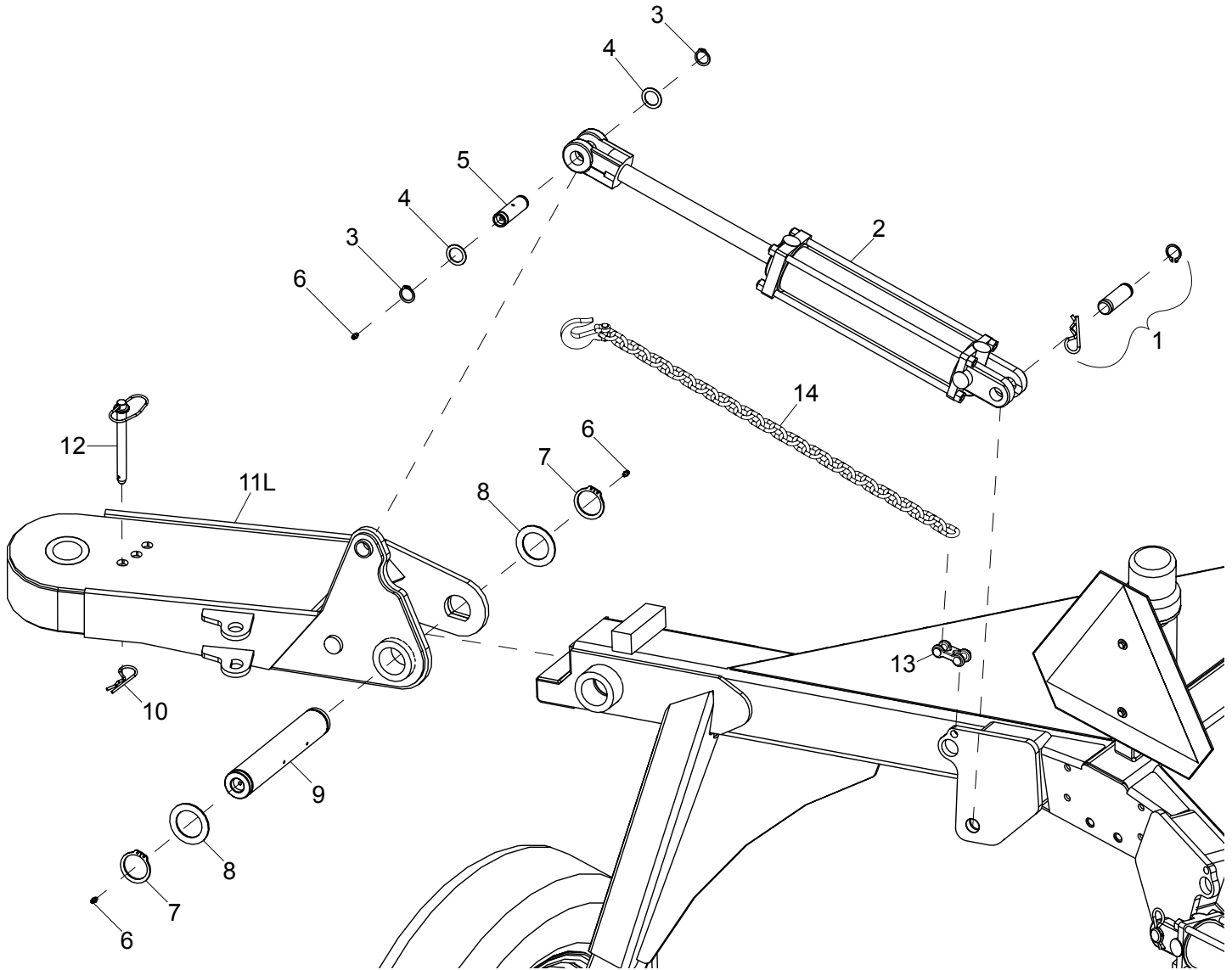

ID	Description	Part #
1	Clevis Pin with Hairpin and Snap Ring	507273
2	3 x 12 Tie Rod Cylinder	510586
3	1" Snap Ring	702883
4	1" Machinery Bushing	001008
5	Outer Cylinder Pin	510574
6	1/2" Grease Fitting	400117
7	2" Snap Ring	510548
8	Pivot Washer	510553
9	Wing Pivot Shaft	510552
10	Hairpin Cotter	100216
11L	Lift Arm Assembly, Left	510515
11R	Lift Arm Assembly, Right (not shown)	510510
12	5/8" x 6-1/2" Pin	510641

Main Beam Assembly

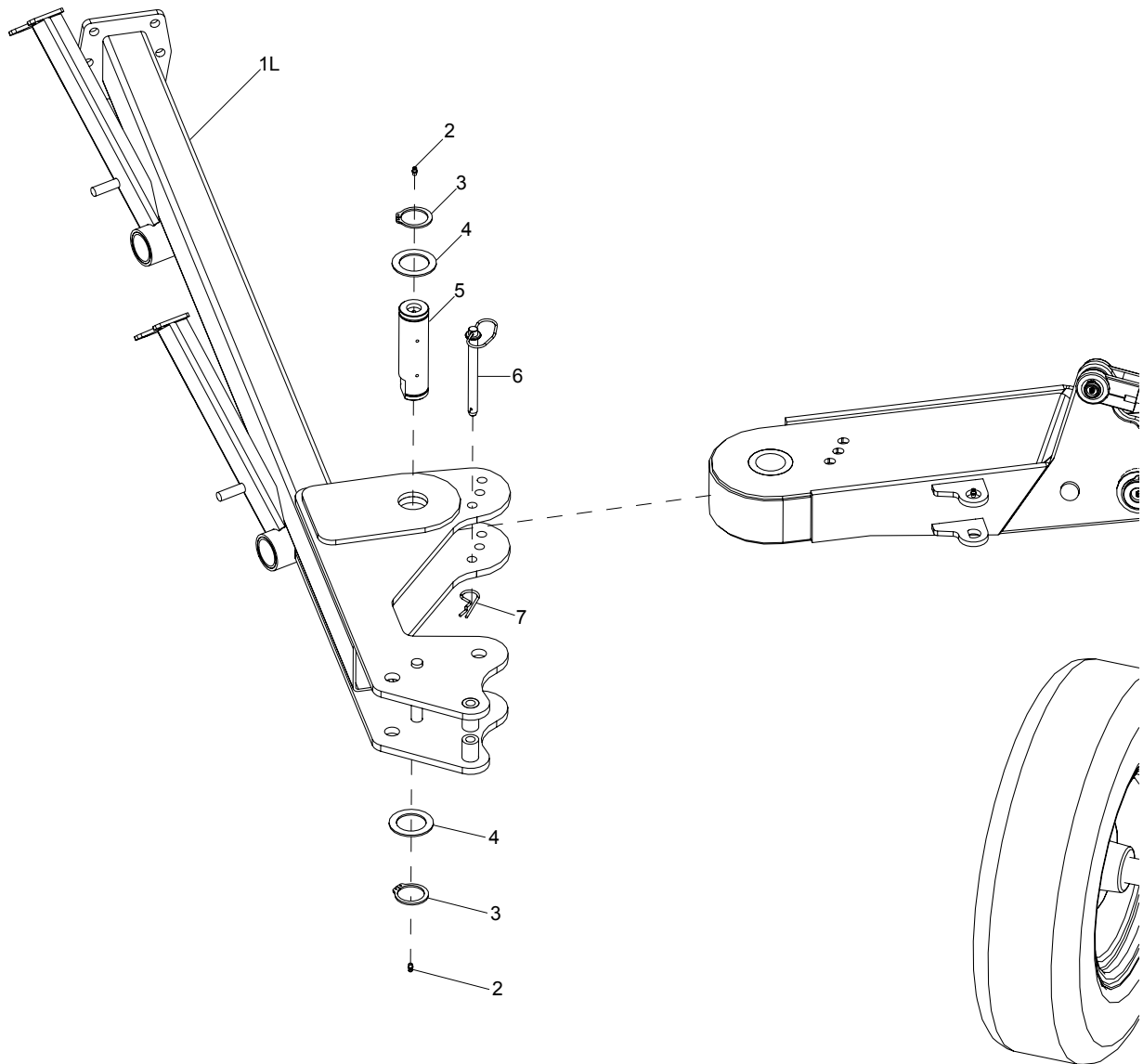

ID	Description	Part #
1L	Left Main Beam	510532
1R	Right Main Beam (not shown)	510512
2	1/4" Drive Grease Zerk	400117
3	2" External Snap Ring (Zinc Plated)	510548
4	Pivot Washer, Plated	510553
5	Arm Pivot Shaft	510557
6	5/8" 6-1/2" Pin	510641
7	Hairpin Cotter	100216

Rear Beam Assembly

Note: Turnbuckle Pivot Location was changed starting at serial number 94641 due to turnbuckle stress fractures. Below is the old style pivot bracket. Turnbuckle is interchangeable.

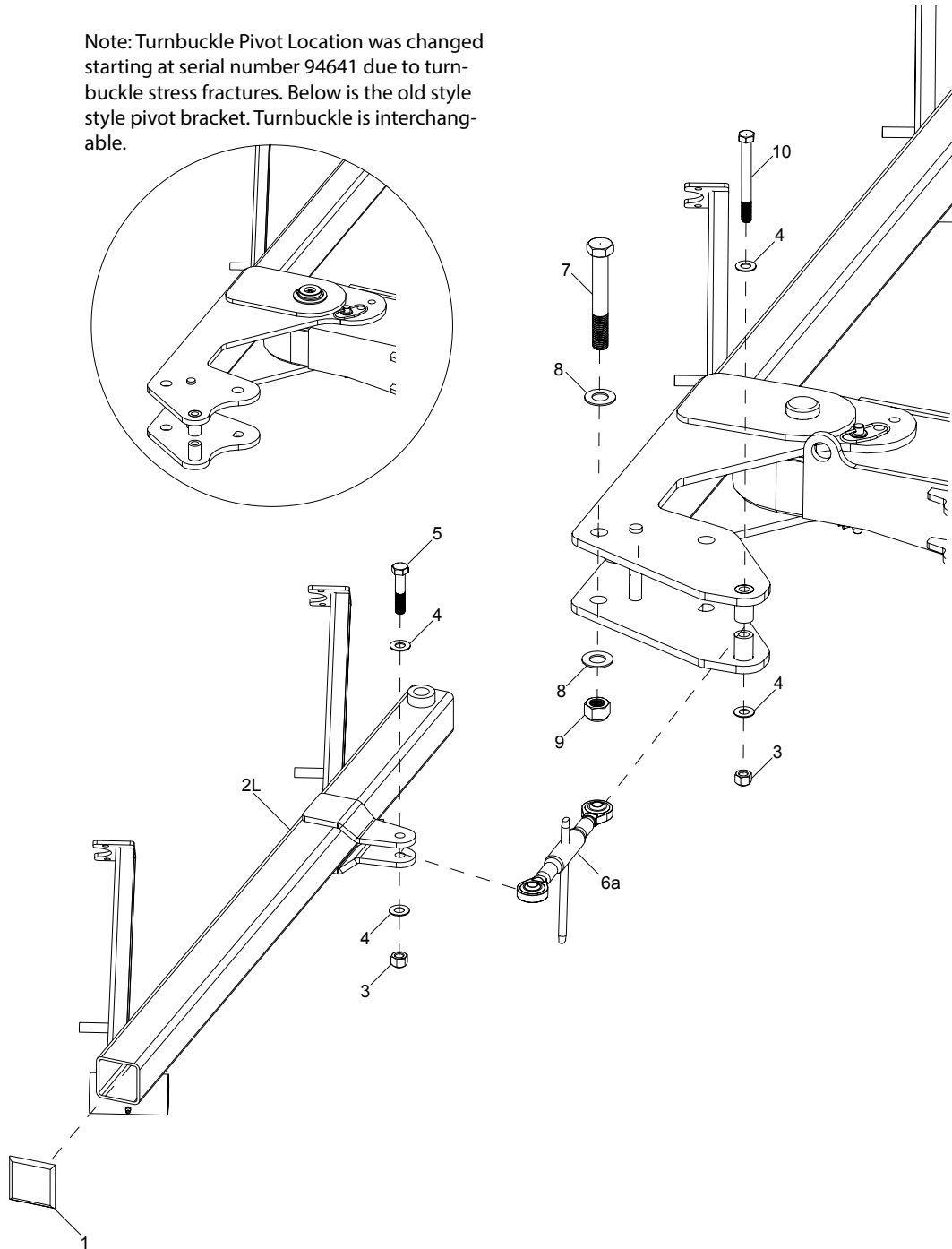

ID	Description	Part #
1	Plastic Caps	508090
2L	Left Rear Wheel Beam	510535
2R	Right Rear Wheel Beam (not shown)	510534
3	5/8" Top Lock Nut	000973
4	5/8" SAE Flat Washer	001076
5	5/8" x 3" Hex Head Bolt	010019

ID	Description	Part #
6a	10" Turnbuckle S/N under 94641	505259
6b	10" Turnbuckle S/N over 94641	510622
7	1" x 7" Hex Head Bolt	000789
8	1" Flat Washer	000879
9	1" Nylon Locknut	001012
10	5/8" x 6" Hex Head Bolt	000665

Front Beam Extensions for 10 & 12 Wheel Rakes

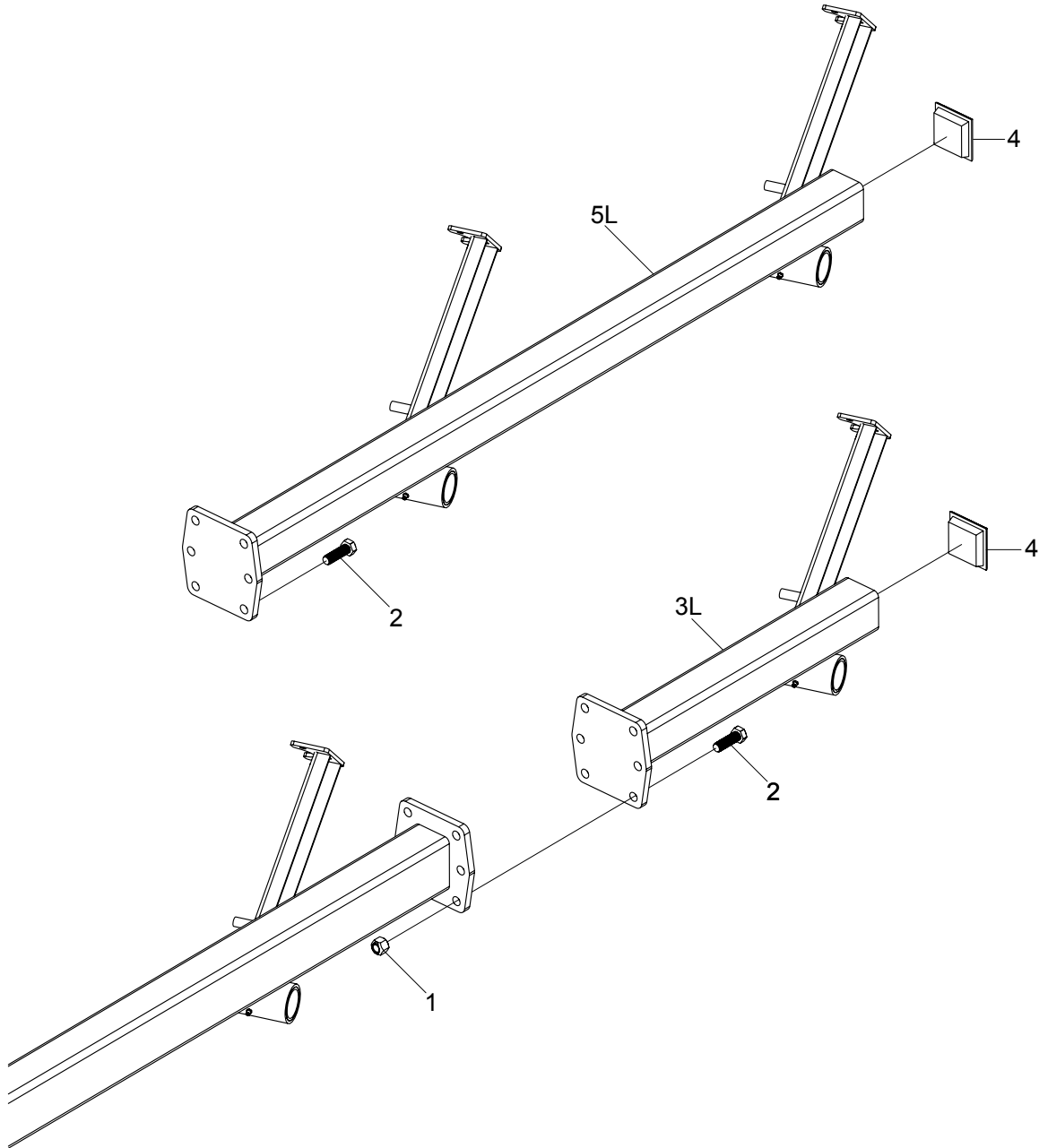

ID	Description	Part #
1	5/8" Top Lock Nut	000973
2	5/8" x 2" Hex Head Bolt	000615
3L	10 Wheel Beam Extension, Left	510605
3R	10 Wheel Beam Extension, Right (not shown)	510603
4	Plastic Cap	508090
5L	12 Wheel Beam Extension, Left	510545
5R	12 Wheel Beam Extension, Right (not shown)	510546

Wheel Arm Spring Assembly

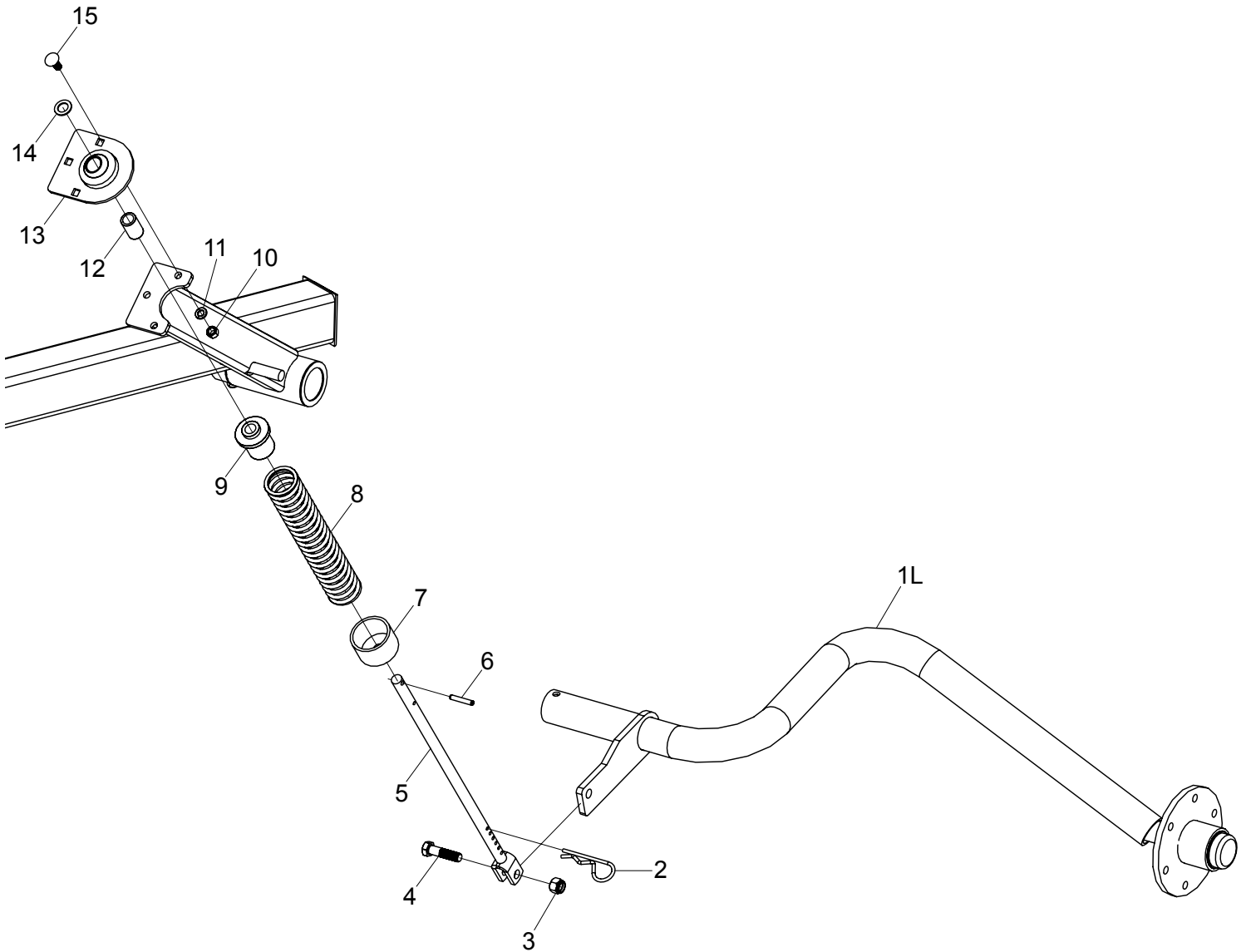

ID	Description	Part #
1L	Left Wheel Arm Weldment	508965
1R	Right Wheel Arm Weldment (not shown)	508967
2	Hairpin Cotter	507340
3	1/2" Nylon Lock Nut	000950
4	1/2" x 2" Hex Head Bolt	000452
5	Spring Assist Rod	510575
6	1/4" x 1-1/2" Roll Pin	000564
7	Spring Cap Weldment	508918

ID	Description	Part #
8	Wheel Lift Spring	508900
9	Plastic Spring Insert	510516
10	3/8" Hex Nut	000915
11	3/8" Lock Washer	000820
12	Ball Bushing	510517
13	Spring Assist Weldment	508964
14	5/8" x 1" Machinery Bushing, 14 Ga.	401442
15	3/8" x 1" Carriage Bolt	000125

Wheel Arm Hub Assembly

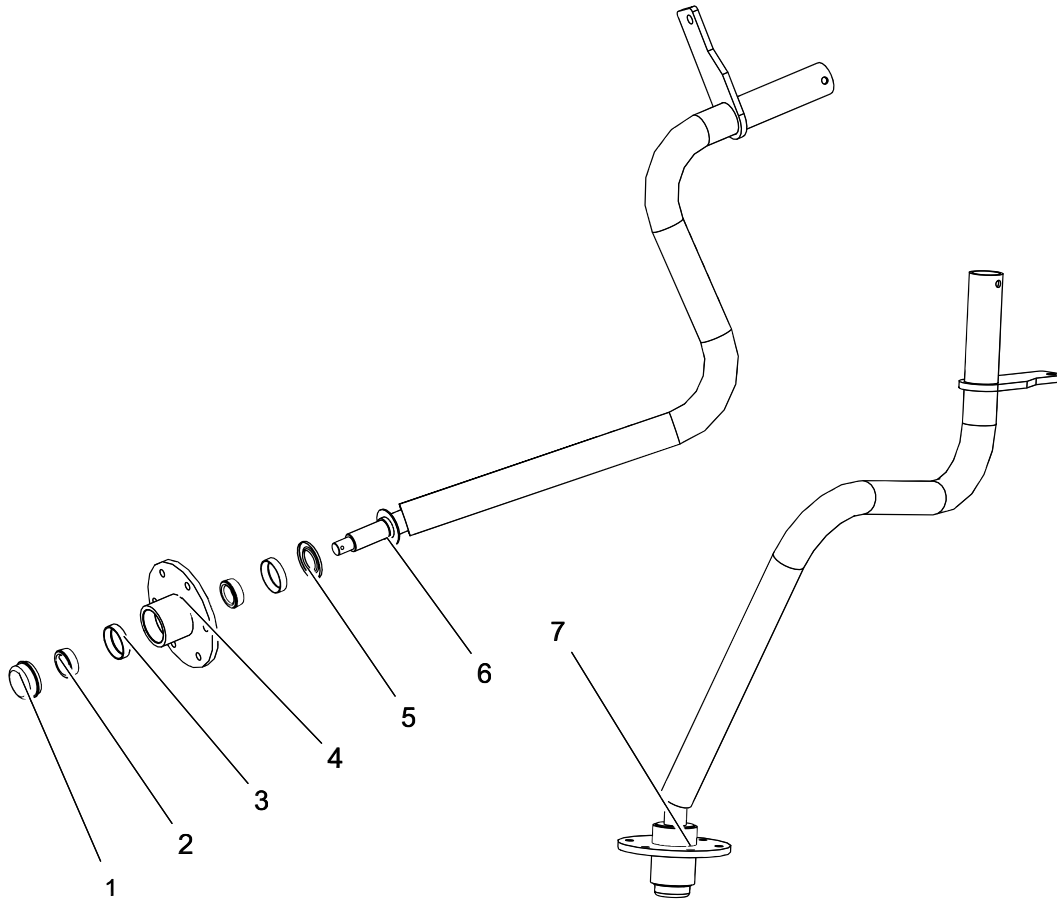

BOM ID	Description	SW Component Name	Qty
1	1.98" OD DUST CAP	508144	1
2	L44649 Tapered Bearing	101469	2
3	L44610 Race	101471	2
4	Rake Wheel Hub	508423	1
5	1.25 ID x 2.25 OD x .25 SEAL	508137	1
6	Left Wheel Arm Weldment	508965	1
7	Right Wheel Arm Weldment	508967	1

Rake Wheel Assembly

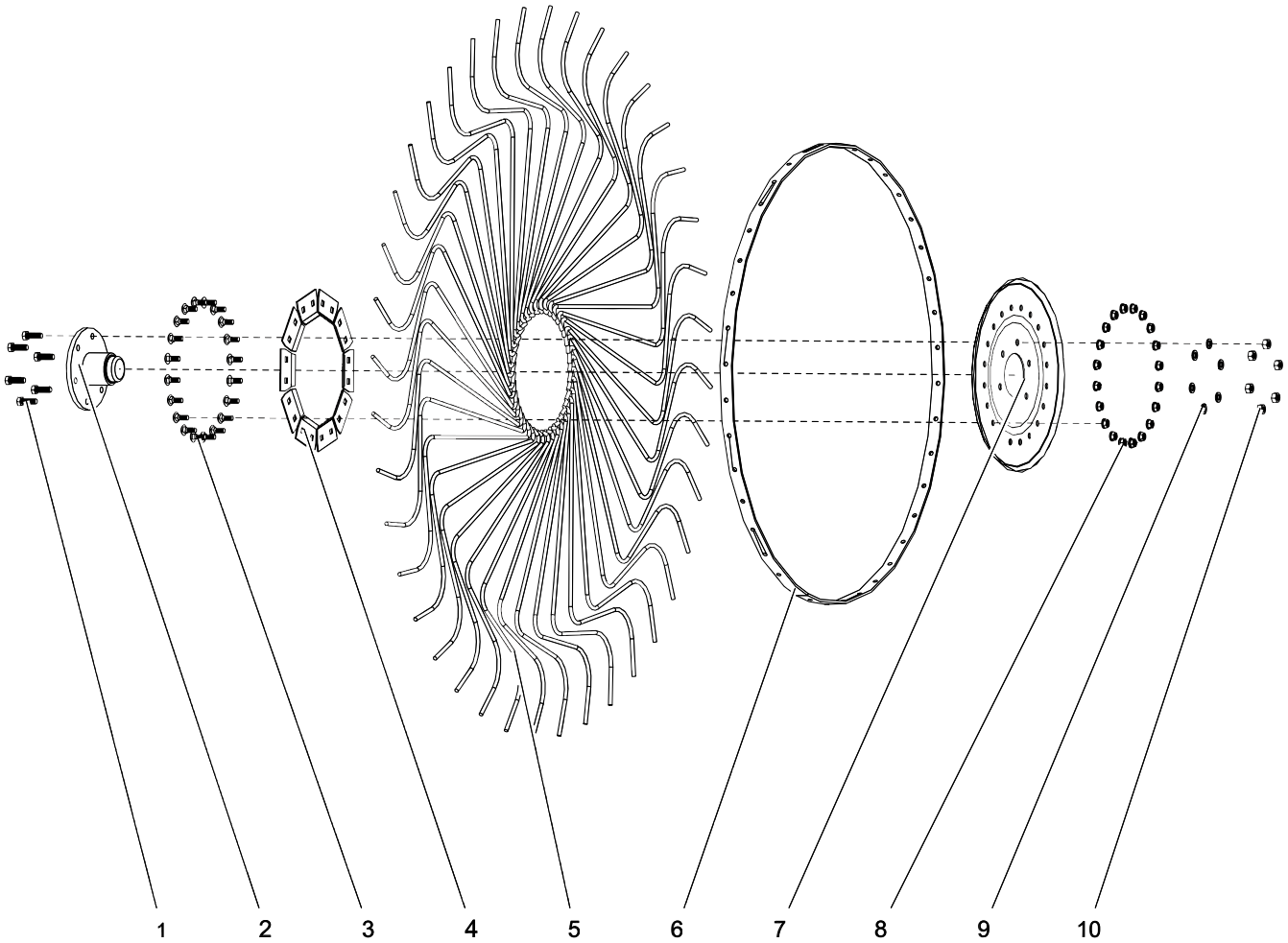

BOM ID	Description	SW Component Name	Qty
1	7/16-14 x 1-1/4 Hex Head Bolt	000355	6
2	RAKE WHEEL HUB ASM	508141	1
3	3/8-16 x 1 Carriage Bolt	000125	20
4	TINE MOUNTING BRACKET	508191	10
5	TURBO RAKE TINE	508086	40
6	Tine Ring	508158	1
7	RAKE WHEEL HUB	508087	1
8	3/8-16 Serrated Flange Nut, Zinc	000916	20
9	7/16 Split Lock Washer	000830	6
10	7/16-14 Hex Nut	000935	6

12 Wheel Beam Extension,-Right

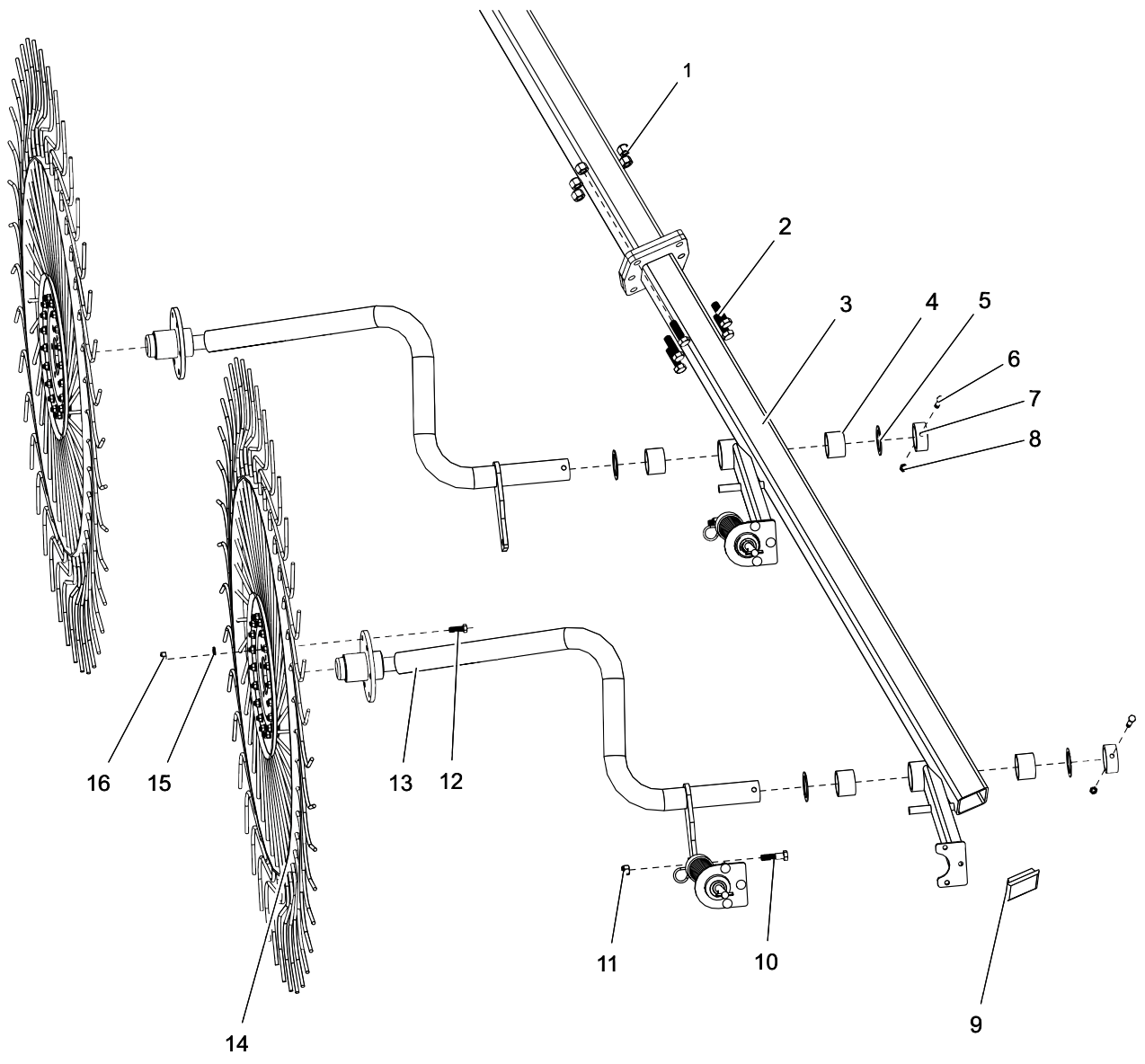

BOM ID	Description	SW Component Name	Qty
1	5/8-11 Top Lock Nut, Zinc	000973	6
2	5/8-11 x 2 Hex Head Bolt	000615	6
3	TR-12 Right Extension	510546	1
4	WHEEL ARM BUSHING	508076	4
5	Wheel Arm Washer	508417	4
6	3/8-16 x 3 Hex Head Bolt	000307	2
7	WHEEL ARM RETAINER	508070	2
8	3/8-16 Nylon Lock Nut	003000	2
9	PLASTIC CAPS	508090	1
10	1/2-13 x 3 Hex Head Bolt	000452	2
11	1/2-13 Nylon Lock Nut	000950	2
12	7/16-14 x 1-1/4 Hex Head Bolt	000355	1
13	Right Wheel Arm Weldment	508967	2
14	55" FINGER WHEEL ASSEMBLY,- RIGHT	508085	2
15	7/16 Split Lock Washer	000830	1
16	7/16-14 Hex Nut	000935	1

12 Wheel Beam Extension,-Left

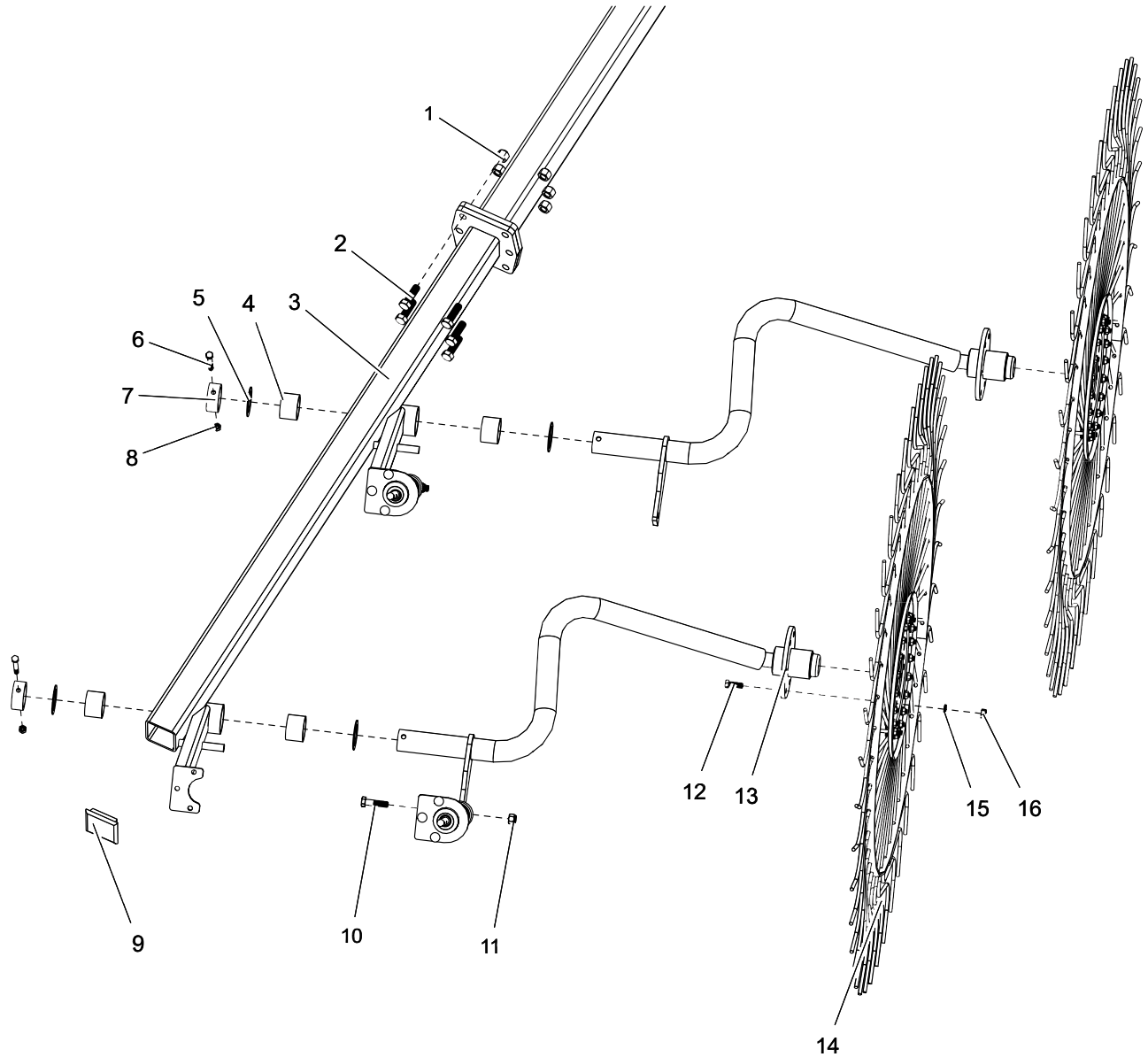

BOM ID	Description	SW Component Name	Qty
1	5/8-11 Top Lock Nut, Zinc	000973	6
2	5/8-11 x 2 Hex Head Bolt	000615	6
3	Left 12 Wheel Ext.	510545	1
4	WHEEL ARM BUSHING	508076	4
5	Wheel Arm Washer	508417	4
6	3/8-16 x 3 Hex Head Bolt	000307	2
7	WHEEL ARM RETAINER	508070	2
8	3/8-16 Nylon Lock Nut	003000	2
9	PLASTIC CAPS	508090	1
10	1/2-13 x 3 Hex Head Bolt	000452	1
11	1/2-13 Nylon Lock Nut	000950	1
12	7/16-14 x 1-1/4 Hex Head Bolt	000355	1
13	Left Wheel Arm Weldment	508965	2
14	55" Finger Wheel Assembly,- Left	508194	2
15	7/16 Split Lock Washer	000830	1
16	7/16-14 Hex Nut	000935	1

10 Wheel Beam Extension,-Right

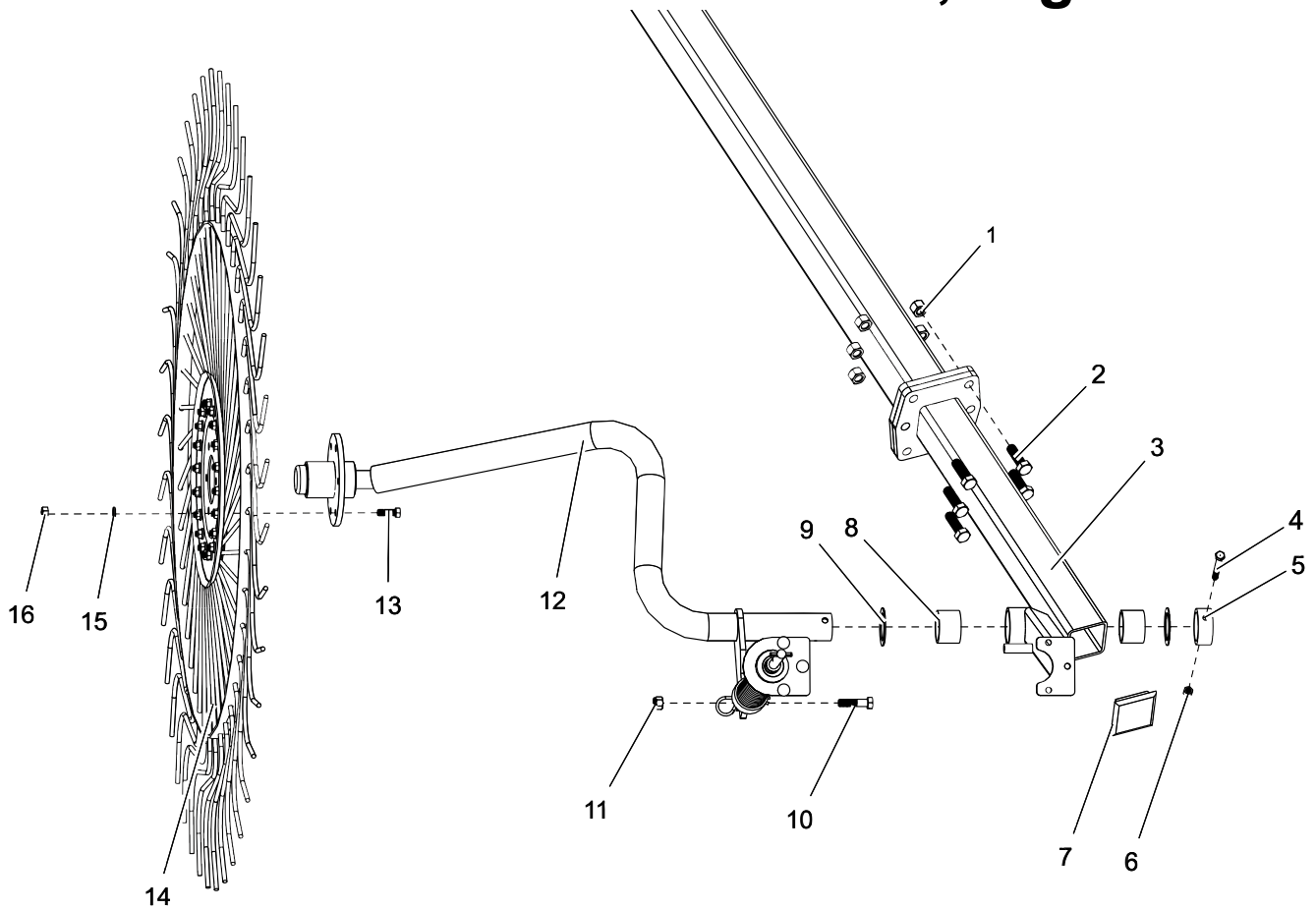

BOM ID	Description	SW Component Name	Qty
1	5/8-11 Top Lock Nut, Zinc	000973	6
2	5/8-11 x 2 Hex Head Bolt	000615	6
3	TR-10 Right Ext	510603	1
4	3/8-16 x 3 Hex Head Bolt	000307	1
5	WHEEL ARM RETAINER	508070	1
6	3/8-16 Nylon Lock Nut	003000	1
7	PLASTIC CAPS	508090	1
8	WHEEL ARM BUSHING	508076	2
9	Wheel Arm Washer	508417	2
10	1/2-13 x 3 Hex Head Bolt	000452	1
11	1/2-13 Nylon Lock Nut	000950	1
12	Right Wheel Arm Weldment	508967	1
13	7/16-14 x 1-1/4 Hex Head Bolt	000355	1
14	55" FINGER WHEEL ASSEMBLY,- RIGHT	508085	1
15	7/16 Split Lock Washer	000830	1
16	7/16-14 Hex Nut	000935	1

10 Wheel Beam Extension,-Left

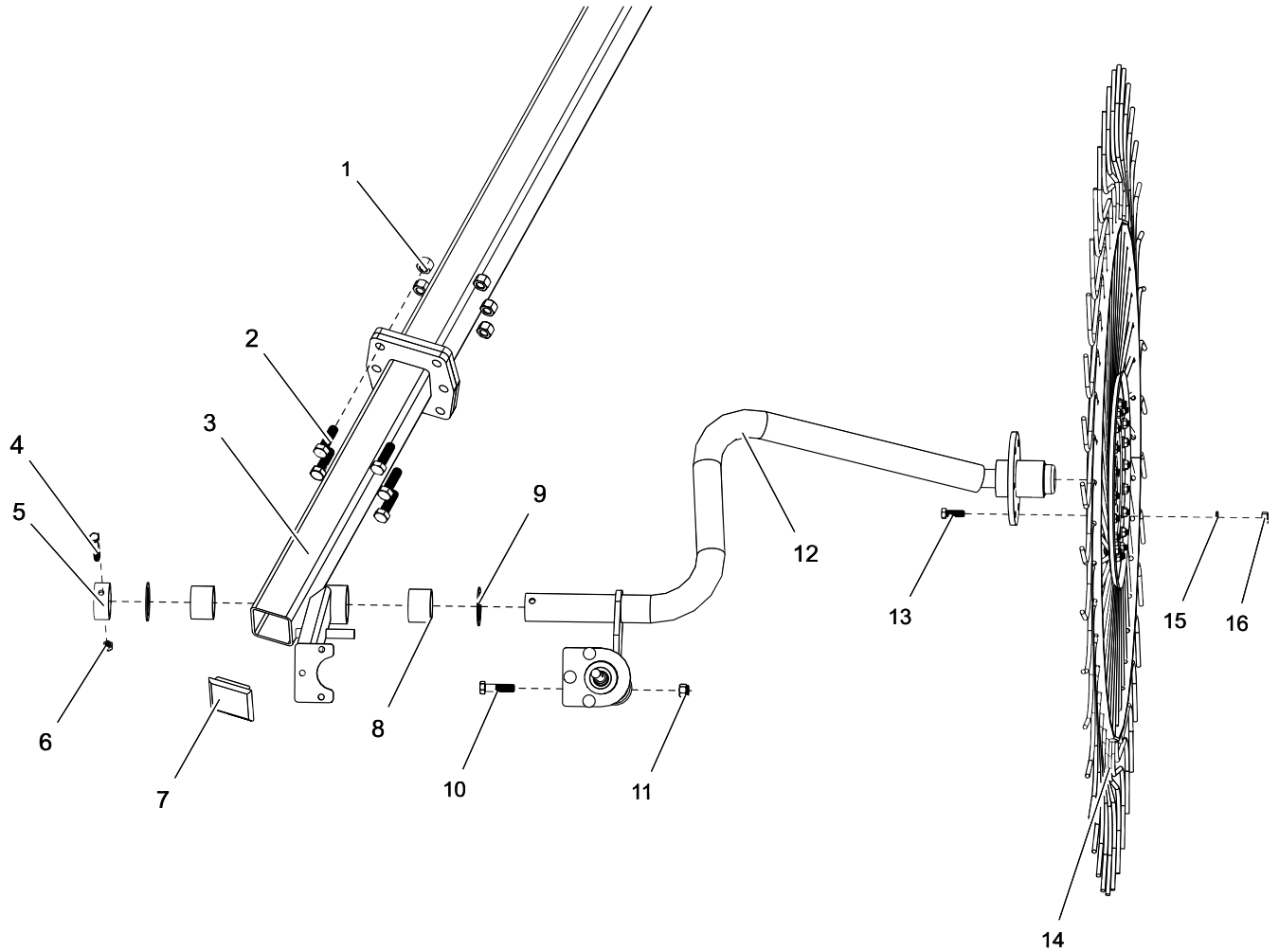

BOM ID	Description	SW Component Name	Qty
1	5/8-11 Top Lock Nut, Zinc	000973	6
2	5/8-11 x 2 Hex Head Bolt	000615	6
3	Left 10 Wheel Ext.	510605	1
4	3/8-16 x 3 Hex Head Bolt	000307	1
5	WHEEL ARM RETAINER	508070	1
6	3/8-16 Nylon Lock Nut	003000	1
7	PLASTIC CAPS	508090	1
8	WHEEL ARM BUSHING	508076	2
9	Wheel Arm Washer	508417	2
10	1/2-13 x 3 Hex Head Bolt	000452	1
11	1/2-13 Nylon Lock Nut	000950	1
12	Left Wheel Arm Weldment	508965	1
13	7/16-14 x 1-1/4 Hex Head Bolt	000355	1
14	55" Finger Wheel Assembly,- Left	508194	1
15	7/16 Split Lock Washer	000830	1
16	7/16-14 Hex Nut	000935	1

Beam Lift Hydraulics

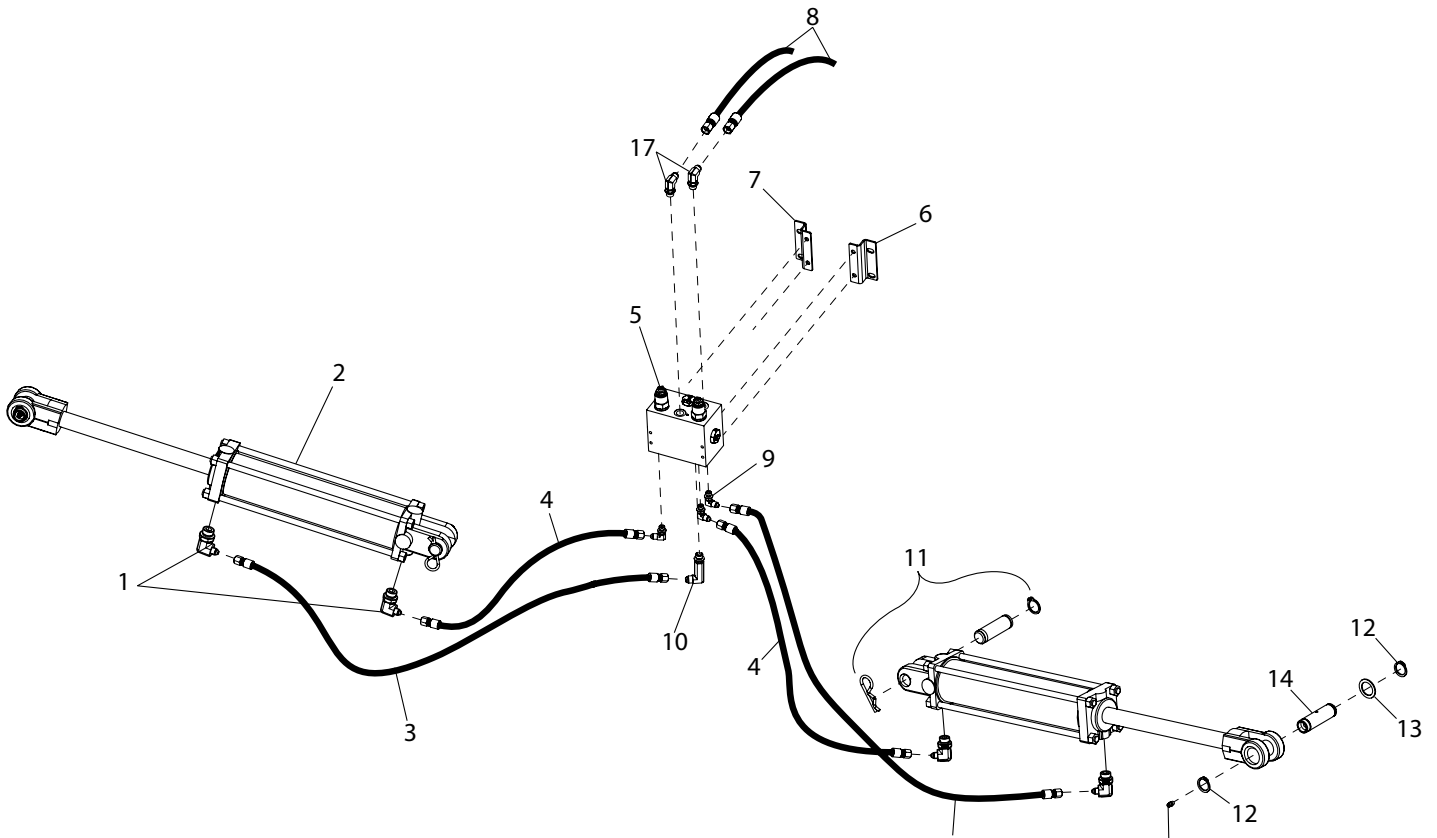

Ref #	Description	Part #	Qty
1	90° Elbow, #4 MJ x #8 MB	290255	4
2	3 x 12 Tie Rod Cylinder	510586	2
3	Lift Cylinder Hose, Base	510615	2
4	Lift Cylinder Hose, Rod End	510614	2
5	Turbo Rake Manifold	510589	1
6	Right Manifold Foot	510640	1
7	Left Manifold Foot	510639	1
8a	8 Wheel Tractor Hose	510651	2
8b	10 Wheel Tractor Hose	510650	2
8c	12 Wheel Tractor Hose	510612	2
9	90° Elbow, #4 MJ x #4 MB	700948	2
10	90° Long Elbow Fitting, #6 MJ x #6 MB	507284	1
11	1" Clevis Pin with Pin and Ring	507273	2
12	1" Snap Ring	702883	2
13	1" Machinery Bushing	001008	2
14	Outer Cylinder Pin	510574	2
15	1/4" Grease Fitting	400117	2

Hydraulic Wheel Beam Assembly

19

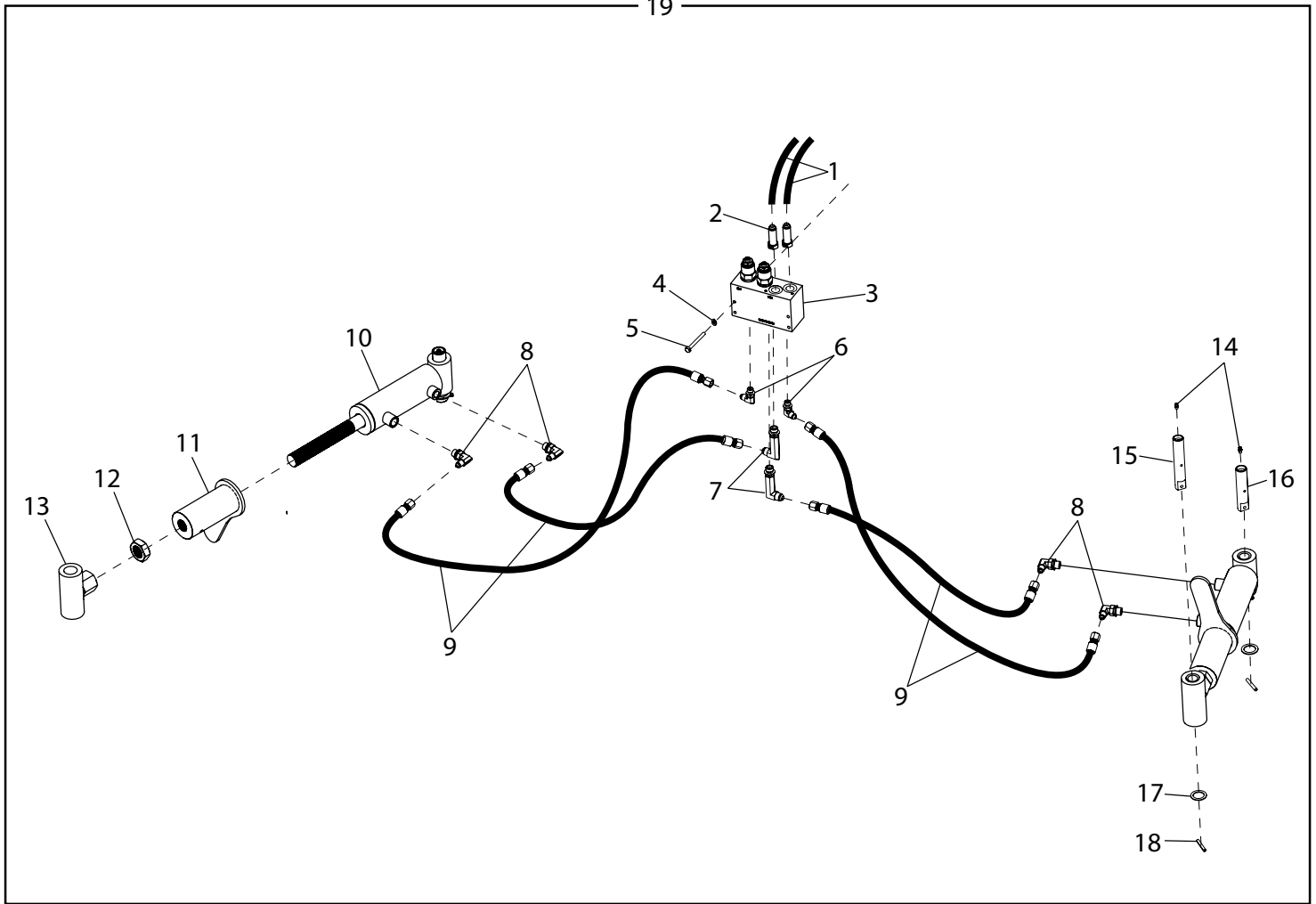

Ref #	Description	Part #	Qty
1a	Tractor Hoses for 8 Wheel Rake	510653	2
1b	Tractor Hoses for 10 Wheel Rake	510654	2
1c	Tractor Hoses for 12 Wheel Rake	510655	2
2	Fitting, 6 - 6L	510638	2
3	Wing Cylinder Manifold	510609	1
4	1/4" Lock Washer	000805	4
5	1/4" x 2-1/2" Hex Head Bolts	000195	4
6	90° Elbow Fitting, #4 MJ x #4 MB	700948	2
7	90° Long Elbow Fitting, #6 MJ x #6 MB	507284	2
8	90 Degree Elbow, #4 MJ x #6 MB	700907	4

Ref #	Description	Part #	Qty
9	Hydraulic Beam Hose 53"	510616	4
10	Rear Wheel Beam Cylinder	510558	2
11	Cylinder Adjustment	510568	2
12	1" Jam Nut	510600	2
13	Beam Cylinder Rod End	510047	2
14	1/4" Spin Drive Fitting	400117	4
15	1" x 5- 7/8" Cylinder Pin	510571	2
16	1" x 4-1/2" Cylinder Pin	700907	4
17	1" Machinery Bushing	001008	4
18	1/4" x 1-3/4" Roll Pin	500187	4
19	Hydraulic Wheel Beam Option	510628	1

Hydraulic Wheel Beam Cylinder

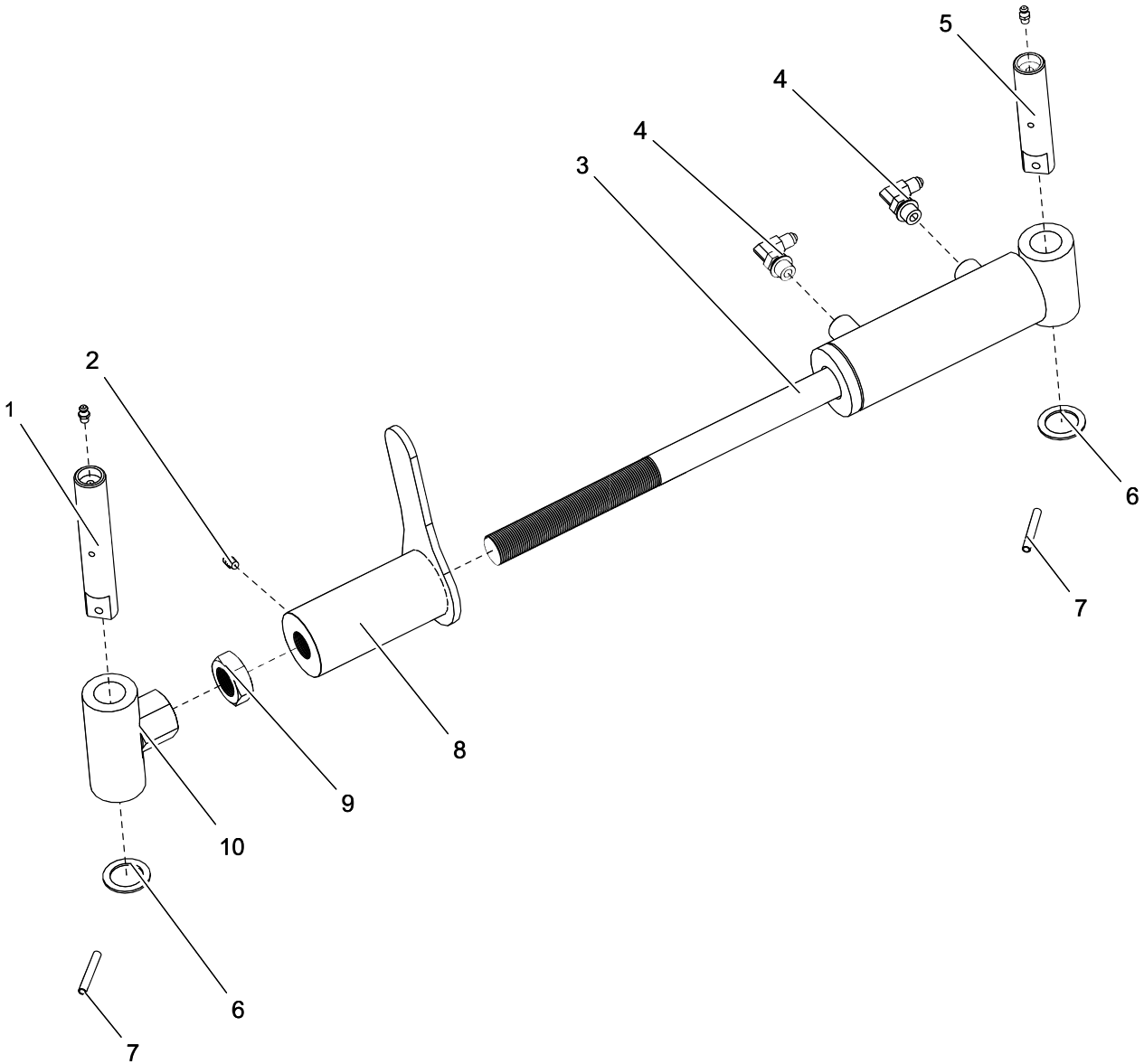

BOM ID	Description	SW Component Name	Qty
1	Cylinder Pin	510571	1
2	1/4-28 SPIN DRIVE FITTING	400117	3
3	Rear Wing cylinder	510558	1
4	#4 JIC x #6 Male Boss Elbow Fitting	700907	2
5	Cylinder Pin	510570	1
6	1" Machinery Bushing 14ga.	001008	2
7	1/4 x 1 3/4 Roll Pin	500187	2
8	Cylinder Adjustment	510568	1
9	1-14 Jam Nut	510600	1
10	Beam Cylinder Rod End	510047	1

Kicker Wheel Kit

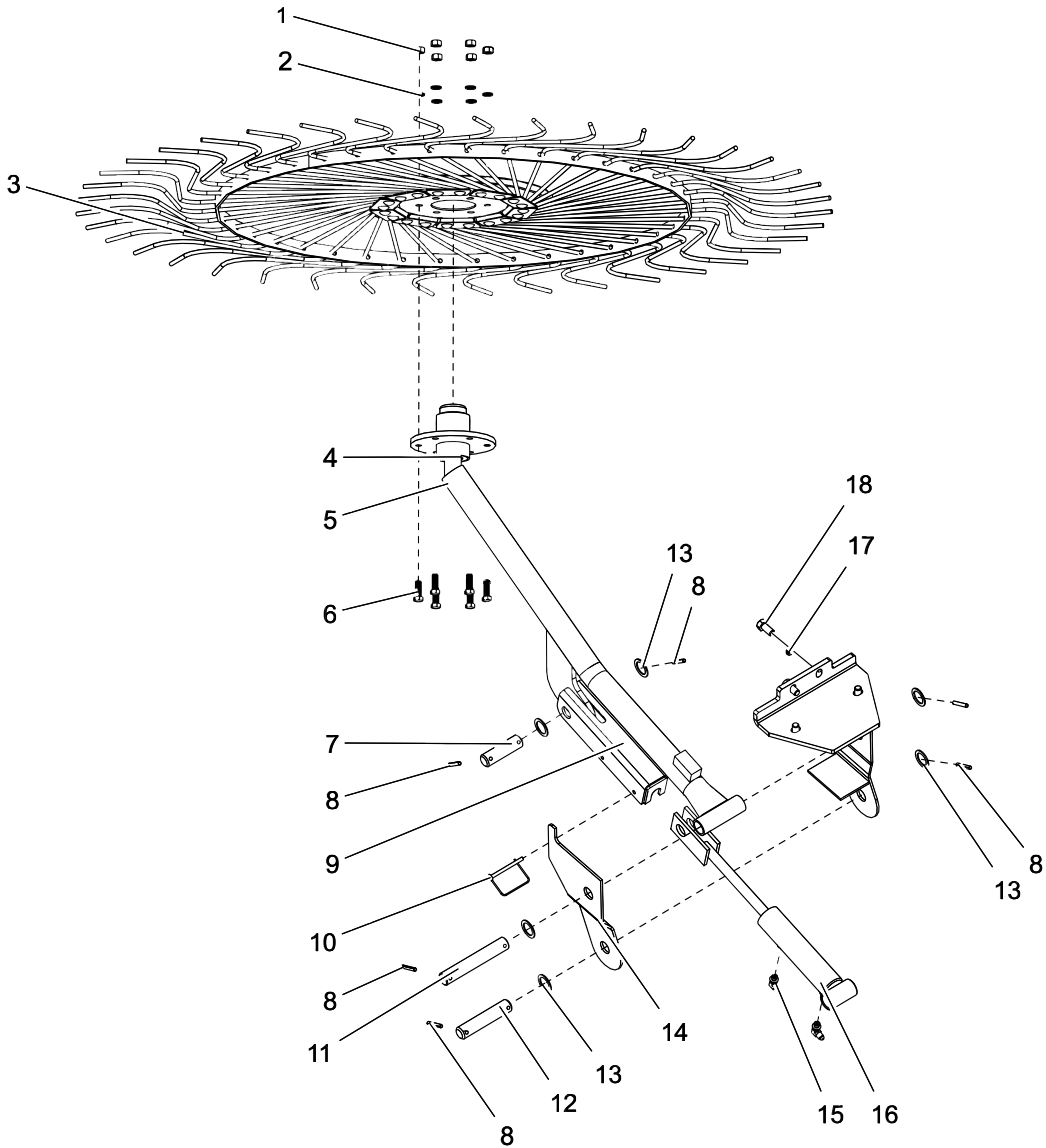

BOM ID	Description	SW Component Name	Qty
1	7/16-14 Hex Nut	000935	6
2	7/16 Split Lock Washer	000830	6
3	55" Finger Wheel Assembly,- Left	508194	1
4	RAKE WHEEL HUB ASM	508423	1
5	KICKER ARM WELDMENT	510591	1
6	7/16-14 x 1-1/4 Hex Head Bolt	000355	6
7	Working Stop Pin	508311	1
8	1/4 x 1 3/4 Roll Pin	500187	6
9	Kicker Cylinder Stop	510561	1
10	1/4 x 2-1/2 Snapper Pin	507186	1
11	TONGUE PIN	507129	1
12	CENTER HYDRAULIC PIN	701021	1
13	1" Machinery Bushing 14ga.	001008	6
14	Kicker Wheel Mounting Weldment	510597	1
15	90 Degree Hydraulic Connection	700948	2
16	Kicker Wheel Cylinder	508404	1
17	1/2 Split Lock Washer	000840	4
18	1/2-13 x 1 HH Bolt	000405	4

Kicker Wheel Hydraulics

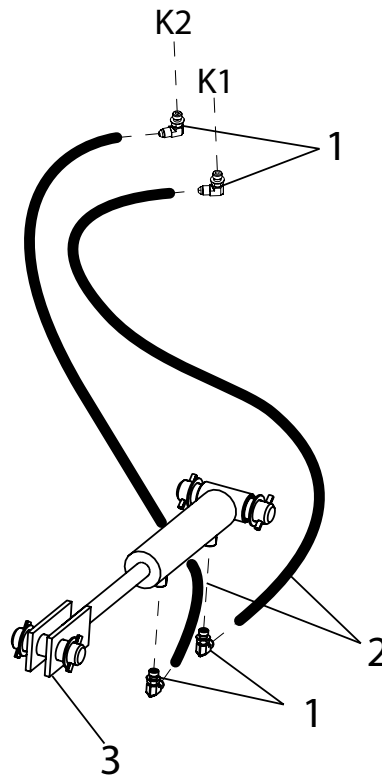

Ref #	Description	Part #	Qty
1	90 Degree Elbow, #4 MJ x #4 MB	700948	4
2	Kicker Wheel Hose	510614	2
3	Kicker Wheel Cylinder	508404	1

Note: See page 1 for additional kicker wheel parts.

Manifold Fittings

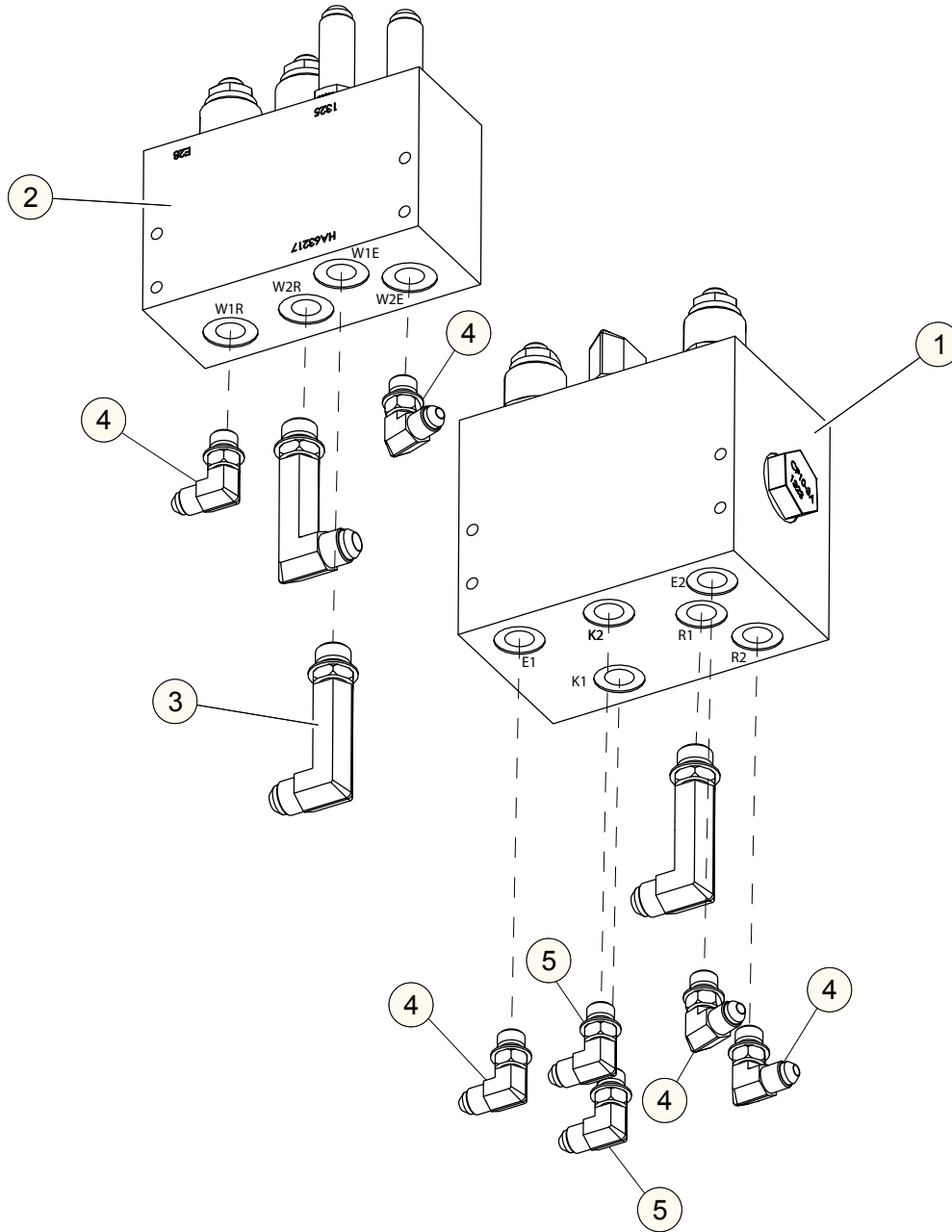

BOM ID	Description	Part #
1	Mid Cap Rake Manifold	510589
2	Wing Cylinder Manifold	510609
3	Adapter- 4MB-4MJ90 Long	510619
4	90 Degree Elbow	700948
5a	90 Degree Elbow, for rakes S/N	700948
5b	90 Degree Elbow with orifice, for rakes S/N	403771