

GRAPPLE KIT

MODEL GK-6078

Part Number 300-040-000

INSTALLATION & PARTS MANUAL

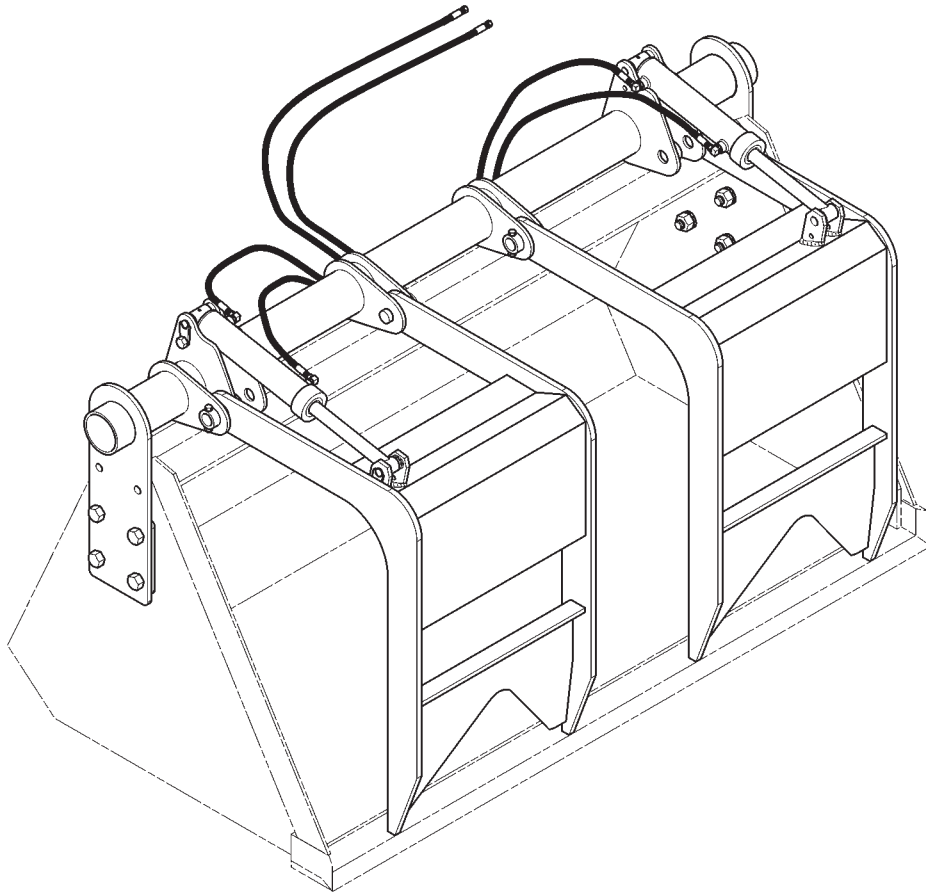

ATI 
CORPORATION

New Holland, PA 17557

Phone (717) 354-8721 • FAX (717) 354-2162

1-800-342-0905

www.preseeder.com

JUNE 2004
CAT.#GK6078IPM-0604

COPYRIGHT 2004 by
ATI Corporation
New Holland, PA 17557 U.S.A.

DISCLAIMER

THE INFORMATION IN THIS MANUAL IS PROVIDED TO PROMOTE THE SAFE USE OF, AND ASSIST THE OPERATOR IN ACHIEVING THE BEST PERFORMANCE FROM, THE GRAPPLE KIT MODEL GK-6078 DESCRIBED HEREIN, FOR THEIR INTENDED APPLICATIONS.

Grapple Kit Model GK-6078



New Holland, PA 17557
Phone (717) 354-8721 • FAX (717) 354-2162
1-800-342-0905
www.preseeder.com

TABLE OF CONTENTS

SUBJECT	PAGE NO.
SERIAL NUMBER INFORMATIONiv
WHERE TO GET PARTS AND SERVICEiv
HOW TO ORDER PARTSv
LIST OF PARTS ILLUSTRATIONSvi
SAFETY, INSTALLATION & MAINTENANCE1



New Holland, PA 17557
 Phone (717) 354-8721 • FAX (717) 354-2162
 1-800-342-0905
 www.preseeder.com

Grapple Kit Model GK-6078

SERIAL NUMBERS, PARTS & SERVICE

SERIAL NUMBER INFORMATION

It is very important that the correct serial number is provided when ordering parts. The serial number plate is located on the grapple hook. Please mark the model and serial number of your attachment in the space provided below in case the plate on your attachment gets lost or damaged.

Model **Serial Number**

Dealer Name **Dealer Phone Number**

WHERE TO GET PARTS AND SERVICE

When replacement parts and service are required for your attachment, ATI Corporation recommends returning to the dealer from which the attachment was purchased. By going to the dealer, you are dealing with people that understand and know your attachment. Our dealers have the experience servicing these machines and stock the most common parts required to keep your attachment in top working condition.

NOTE:

ATI Corporation reserves the right to discontinue models at any time, change specifications, and improve design without notice and without incurring obligation on goods previously purchased and to discontinue supplying any part listed, when the demand does not warrant production.

Grapple Kit Model GK-6078



New Holland, PA 17557
Phone (717) 354-8721 • FAX (717) 354-2162
1-800-342-0905
www.preseeder.com

HOW TO ORDER PARTS

Parts lists contained in this book have been prepared to help you when ordering spare and/or replacement parts. Your order will be filled promptly and accurately when the following information is provided to your dealer:

1. Model and serial number of the unit. (This specifically identifies the equipment you have and permits us to verify the part numbers in your order.)
2. The parts list page number and catalog number. Include catalog revision number, if applicable.
3. The **Item** number for each part. **Item** numbers on the parts list page correspond with the numbers shown on the illustration.
4. **Part Number** as it appears in the parts list. In most cases this will be a nine-digit number; for example: 200-147-000.
5. The **Description** for the part as it appears on the parts list page.

When a complete assembly is needed, use the assembly number given in the parts list. If no assembly number is given, order by main assembly title and list only the item numbers you want. For example: "Cylinder Assembly, 1-3/4" Bore x 6" Stroke per 000-166-097, Items 2 through 15 inclusive".

The part ordered may have a new part number, or the part may have been replaced by a newer design with a different part number. In these cases your acknowledgement, shipping papers and invoices will be written listing the current part number first; the old part number you referred to will follow the part description.

Our purpose in doing this is to tell you that the parts are fully interchangeable. This will avoid any unnecessary correspondence or delay in processing your order. We suggest that you add any new number to your parts lists for future use.



New Holland, PA 17557
 Phone (717) 354-8721 • FAX (717) 354-2162
 1-800-342-0905
 www.preseeder.com

Grapple Kit Model GK-6078

LIST OF PARTS ILLUSTRATIONS

Figure 1. Parts Included	1
Figure 2. Mounting Tube to Grapple Hook.....	2
Figure 3. Hydraulic Cylinder Installation.....	2
Figure 4. Mounting Plates on Tube.....	2
Figure 5. Welding Mounting Plates on Tube.....	3
Figure 6. Cutting Excess off Tube.....	3
Figure 7. Mounting Tube, Plates, Grapple Hooks & Related Parts.....	4
Figure 8. Hydraulics	6
Figure 9. Cylinder Assembly	8

Grapple Kit Model GK-6078



New Holland, PA 17557
Phone (717) 354-8721 • FAX (717) 354-2162
1-800-342-0905
www.preseeder.com

SAFETY, INSTALLATION & MAINTENANCE

SAFETY

SAFETY is our first concern at ATI Corporation. Safety must also be first in the mind of the grapple bucket operator. Proper maintenance is necessary to complete the safety cycle.

Observe all safety rules, including:

- Operate at a safe distance from bystanders.
- Never perform maintenance or service work like lubricating, inspecting, clearing debris, etc., while the tractor engine is running. Shut off the engine and remove the key before performing these functions.

CAUTION DO NOT EXCEED THE LOADER'S SAE OPERATING LOAD. See the operator's manual of the loader for load specifications. Remember to include the weight of the grapple kit in the total weight to be lifted by the loader.

PRESSURIZED OIL LEAKS CAN PENETRATE YOUR SKIN. Before investigating or repairing leaks, shut off the tractor engine and move the hydraulic control valve to open and close positions several times, to relieve pressure in the hydraulic lines.

INSTALLATION

Tools needed to complete job: (2) 7/16" Wrenches, (2) 1/2" Wrenches, (2) 3/4" Wrenches, Electric Welder, 1/2" Electric Drill, 17/32" Drill Bit, Hacksaw and (2) "C" Clamps or equivalent.

CAUTION Weld in a well-ventilated area. Burning paint may create toxic fumes that should not be inhaled. Wear proper protective equipment when welding.

1. Checklist of parts.

If any parts are missing, please contact your dealer immediately.

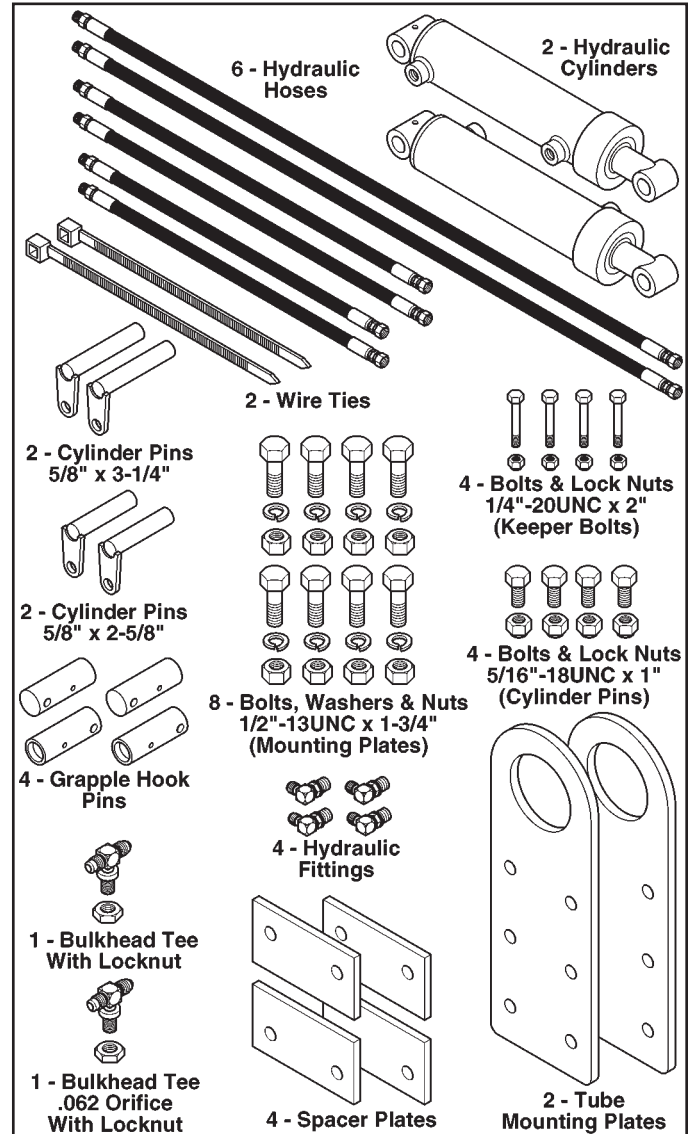

Figure 1. Parts Included

SAFETY, INSTALLATION & MAINTENANCE

2. Pin hook assembly to mounting tube.

Lay mounting tube and hooks on level surface. Slide hook bosses into ears of the mounting tube and fasten with the four hook pins. Insert keeper bolts (1/4"-20UNC x 2") and fasten with lock nuts. See Figure 2.

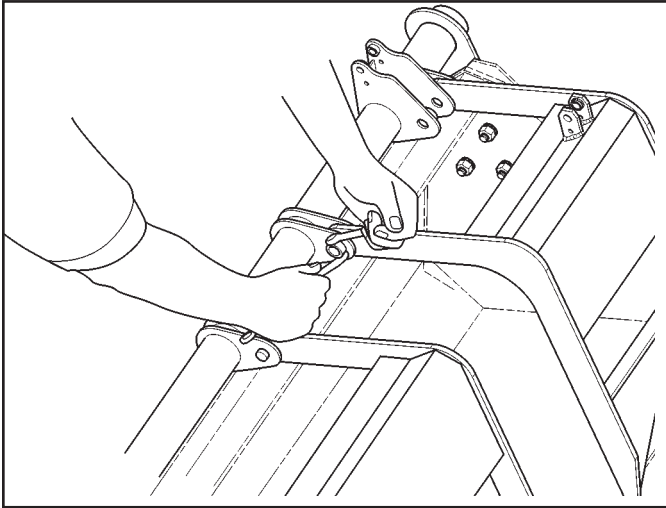

Figure 2. Mounting Tube to Grapple Hooks

3. Install hydraulic cylinders.

Insert the barrel end of the cylinder into the ears of the mounting tube, and secure with 5/8" x 3-1/4" cylinder pin and bolt (5/16"-18UNC x 1") with lock nut. See Figure 3.

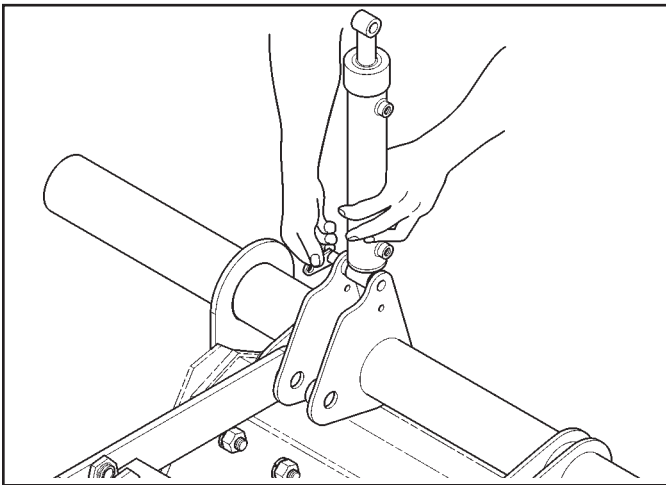

Figure 3. Hydraulic Cylinders Installation

4. Fully extend the hydraulic cylinders.

5. Place the grapple assembly on the loader bucket.

The tips of the grapple tines should rest on the bucket's cutting edge. To provide better clamping ability, the hydraulic cylinders should be retracted 1/4" from full extension. Be sure tips of the tines continue to rest on cutting edge.

6. Install mounting plates on tube.

Raise and support the mounting tube so that the tines are clear of the back of the bucket. Slide the tube mounting plates over the ends of the mounting tube. Remember to keep the grapple tines on the bucket edge. Hold mounting plates in place with "C" clamps or an equivalent clamp. Use the tube mounting plates as a template for drilling. Drill two holes in each end of the bucket. See Figure 4. If the bucket has reinforced end sheets, the 1/2" rectangular spacers may be needed to shim the tube mounting plates for proper installation. If the grapple will be frequently removed and reinstalled, the 1/2" rectangular spacers will make installation and removal easier. Install two of the bolts (1/2"-13UNC x 1-3/4"), lock washers, and nuts in each end of the bucket and tighten. Center the mounting tube in the mounting plates and tack weld in place.

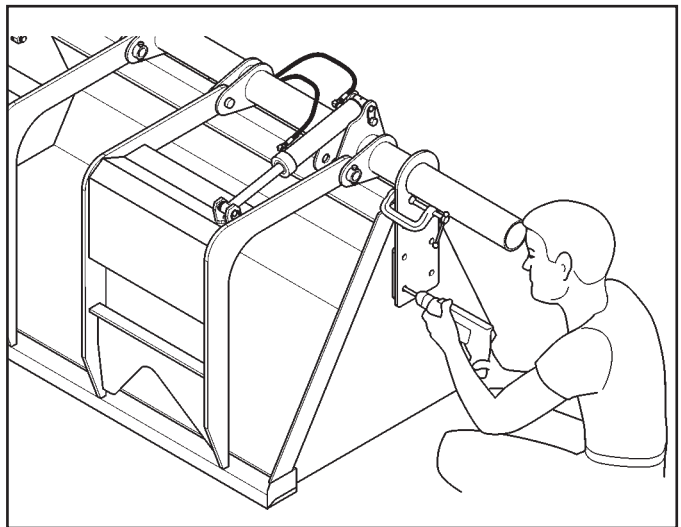

Figure 4. Mounting plates on tube

Grapple Kit Model GK-6078



New Holland, PA 17557
Phone (717) 354-8721 • FAX (717) 354-2162
1-800-342-0905
www.preseeder.com

SAFETY, INSTALLATION & MAINTENANCE

7. Check for any interference.

Operate the loader and grapple through their full range of motion to ensure that the grapple does not interfere with the tractor, loader, cylinders, or hydraulic hoses. If there is any interference, redo steps 6 and 7.

8. Complete mounting.

The complete grapple kit must be fastened to the bucket with at least three, preferably four, bolts on each end. Some buckets will only have room for three bolt holes per side. Drill the additional holes required. Fasten securely with the remaining hardware. Weld mounting tube to the tube mounting plates. See Figure 5.

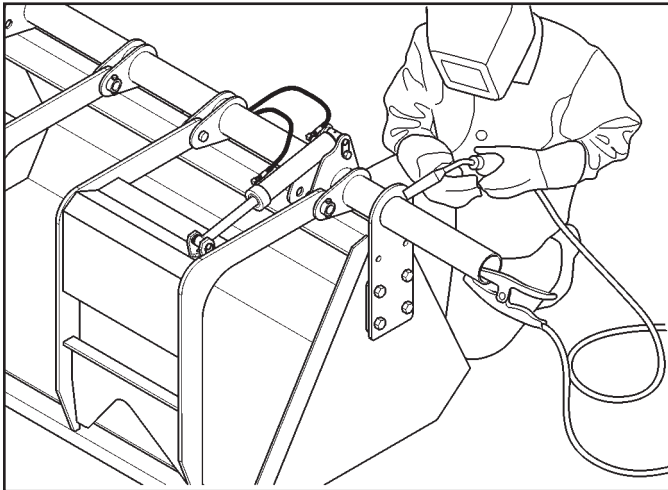

Figure 5. Welding mounting plates on tube

9. Trim tube.

Trim off excess mounting tube with hacksaw. See Figure 6

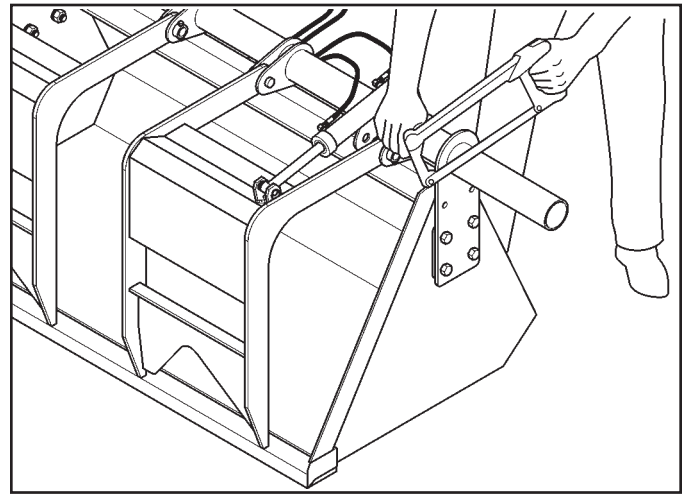

Figure 6. Cutting excess off tube

10. Plumb hydraulic power to grapple assembly.

The grapple kit includes 3/8" hoses with 8MB fittings on the end. See your dealer for quick couplers, additional hose, fittings, and tractor remote hydraulic valve.

MAINTENANCE

- Lubricate all grease fittings every ten(10) hours of operation.
- Check all hydraulic hoses frequently for leaks or damage.
- Replace defective hoses before operating the grapple.
- Check all pivot pins and fasteners; replace them as needed.
- Remember that well-maintained equipment is safer, performs better, and provides longer service life!



New Holland, PA 17557
Phone (717) 354-8721 • FAX (717) 354-2162
1-800-342-0905
www.preseeder.com

Grapple Kit Model GK-6078 PARTS LIST

Figure 7. Mounting Tube, Plates, Grapple Hooks & Related Parts

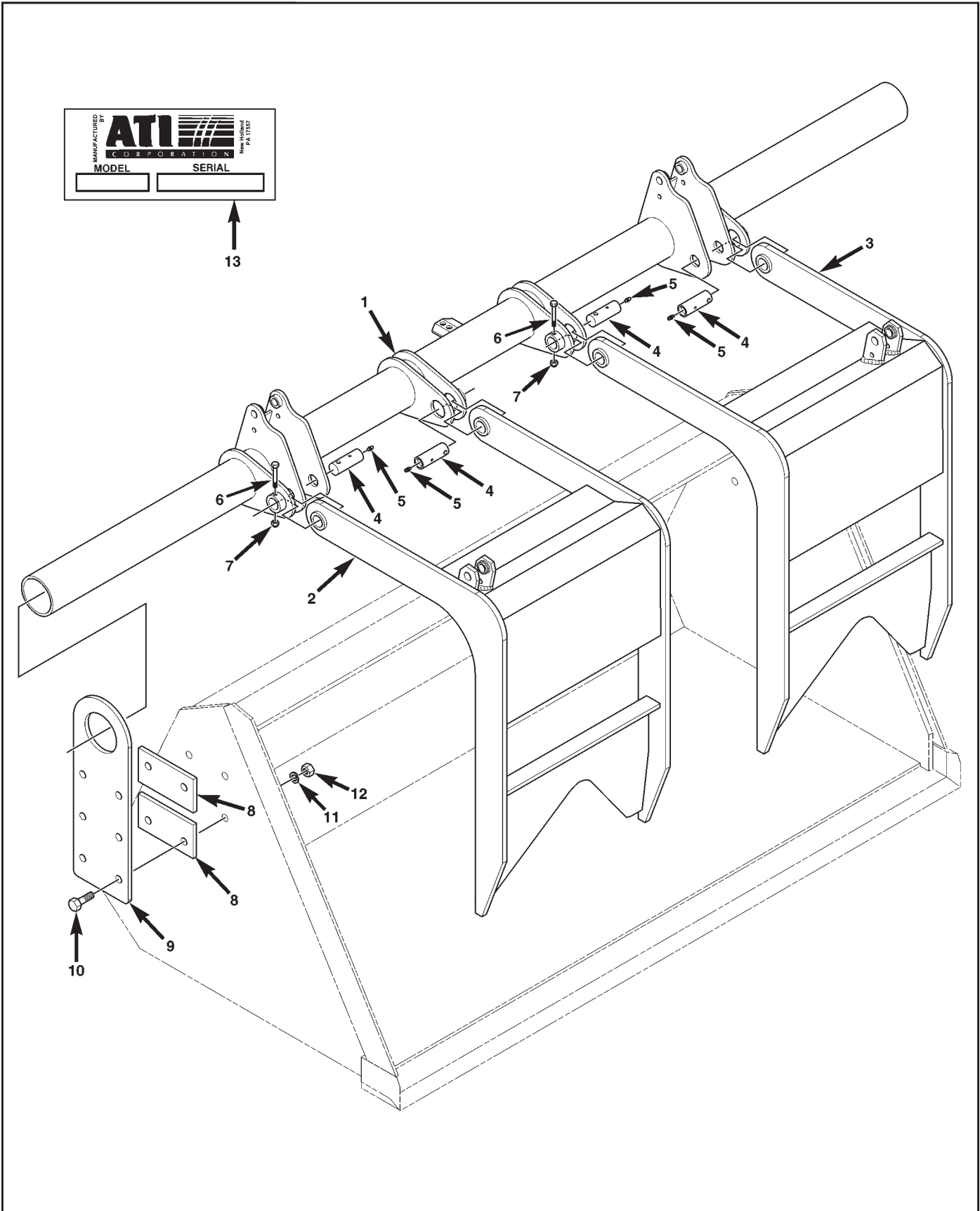

Grapple Kit Model GK-6078

PARTS LIST



New Holland, PA 17557
 Phone (717) 354-8721 • FAX (717) 354-2162
 1-800-342-0905
 www.preseeder.com

Figure 7. Mounting Tube, Plates, Grapple Hooks & Related Parts

Item	Part No.	Qty	Description
1	300-111-000	1	Tube, Mounting
2	300-113-000	1	Hook, Grapple, Right Hand
3	300-112-000	1	Hook, Grapple, Left Hand
4	000-161-035	4	Pin, Grapple Hook, 1" Dia. x 2-3/4" Long
5	LP	4	Fitting, Lube, 1/4"-28UNF
6	LP	4	Bolt, Hex Head, 1/4"-20UNC x 2" Long
7	LP	4	Nut, Hex, Nylon Lock, 1/4"-20UNC
8	300-114-000	4	Plate, Spacer
9	300-115-000	2	Plate, Tube Mounting
10	LP	8	Bolt, Hex Head, 1/2"-13UNC x 1-3/4" Long
11	LP	8	Washer, Lock, 1/2"
12	LP	8	Nut, Hex, 1/2"-13UNC
13	000-186-035	1	Plate, Serial, Adhesive Back

AR - As Required NSS - Not Serviced Separately ASN - After Serial No. BSN - Before Serial No. LP - Local Purchase



New Holland, PA 17557
Phone (717) 354-8721 • FAX (717) 354-2162
1-800-342-0905
www.preseeder.com

Grapple Kit Model GK-6078

PARTS LIST

Figure 8. Hydraulics

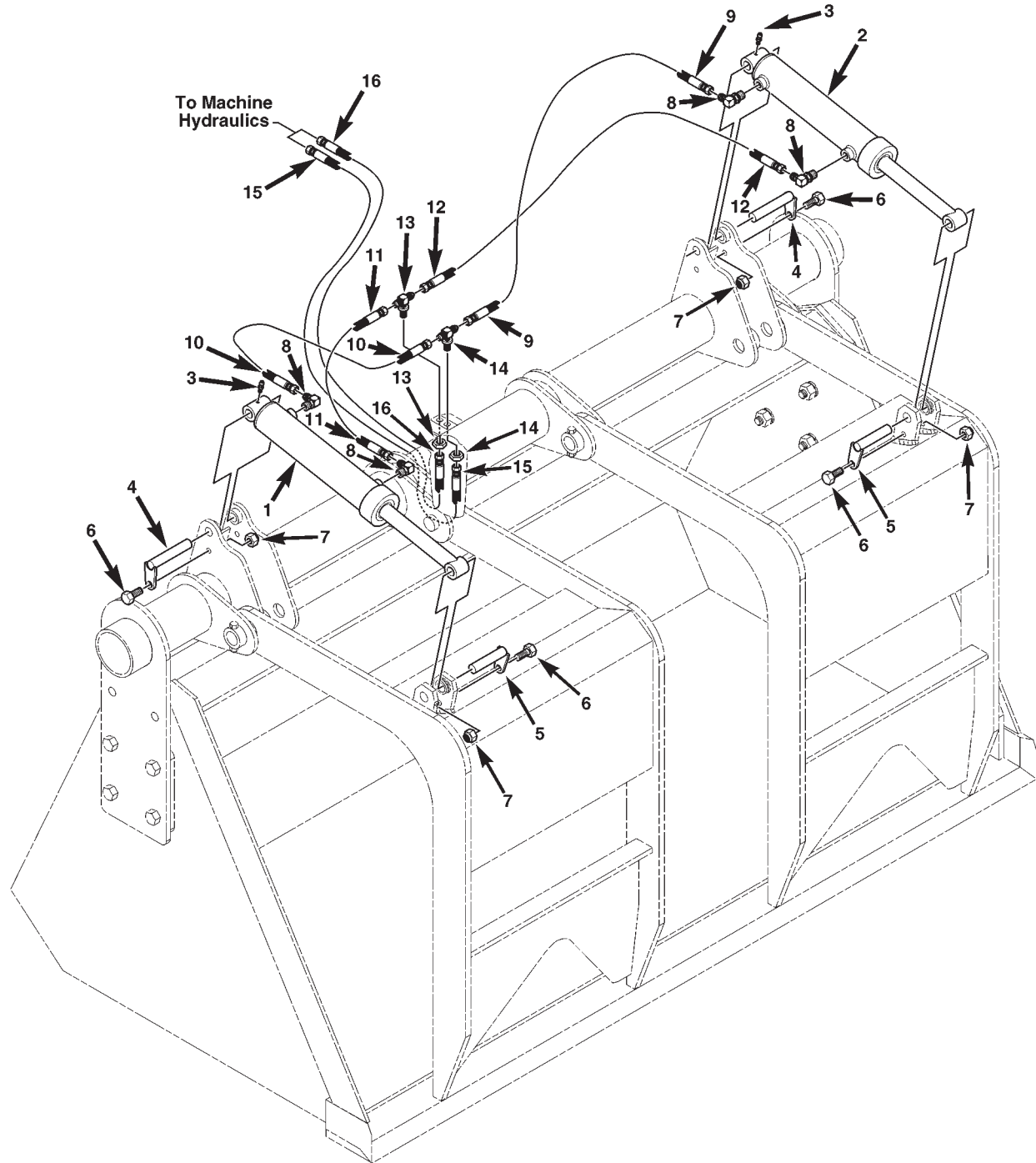

Grapple Kit Model GK-6078

PARTS LIST

Figure 8. Hydraulics



New Holland, PA 17557
 Phone (717) 354-8721 • FAX (717) 354-2162
 1-800-342-0905
 www.preseeder.com

Item	Part No.	Qty	Description
1	000-166-097	1	Cylinder Assembly, Right Hand, 1-3/4" Bore x 6" Stroke (See Breakdown)
2	000-166-080	1	Cylinder Assembly, Left Hand, 1-3/4" Bore x 6" Stroke (See Breakdown)
3	LP	2	Fitting, Lube, 3/16" Drive
4	000-161-041	2	Pin, Cylinder, w/Tab, 5/8" Dia. x 3-1/4" Long
5	000-161-040	2	Pin, Cylinder, w/Tab, 5/8" Dia. x 2-5/8" Long
6	LP	4	Bolt, Hex Head, 5/16"-18UNC x 1" Long
7	LP	4	Nut, Hex, Nylon Lock, 5/16"-18UNC
8	000-166-048	4	Elbow, 4MJ x 4MB, 90°
9	000-166-117	1	Hose, Hydraulic, 1/4" x 4FJX x 6FJX x 26" Long
10	000-166-117	1	Hose, Hydraulic, 1/4" x 4FJX x 6FJX x 26" Long
11	000-166-118	1	Hose, Hydraulic, 1/4" x 4FJX x 6FJX x 33" Long
12	000-166-118	1	Hose, Hydraulic, 1/4" x 4FJX x 6FJX x 33" Long
13	000-166-102	1	Tee, Bulkhead, with Locknut, 6MJ X 6MJ x 6BH
14	000-166-130	1	Tee, Bulkhead, with Locknut, 6MJ X 6MJ x 6BH, With .062 Orifice
15	000-166-116	1	Hose, Hydraulic, 3/8" x 8MB x 6FJX x 65" Long
16	000-166-116	1	Hose, Hydraulic, 3/8" x 8MB x 6FJX x 65" Long
			BH-Bulkhead
			MP-Male Pipe
			FP-Female Pipe
			FPX-Female Pipe Swivel
			MB-Male O-Ring Boss
			FB-Female O-Ring Boss
			MJ-Male JIC
			FJ-Female JIC
			FJX-Female JIC Swivel
<p>AR - As Required NSS - Not Serviced Separately ASN - After Serial No. BSN - Before Serial No. LP - Local Purchase</p>			



New Holland, PA 17557
Phone (717) 354-8721 • FAX (717) 354-2162
1-800-342-0905
www.preseeder.com

Grapple Kit Model GK-6078

PARTS LIST

Figure 9. Cylinder Assembly

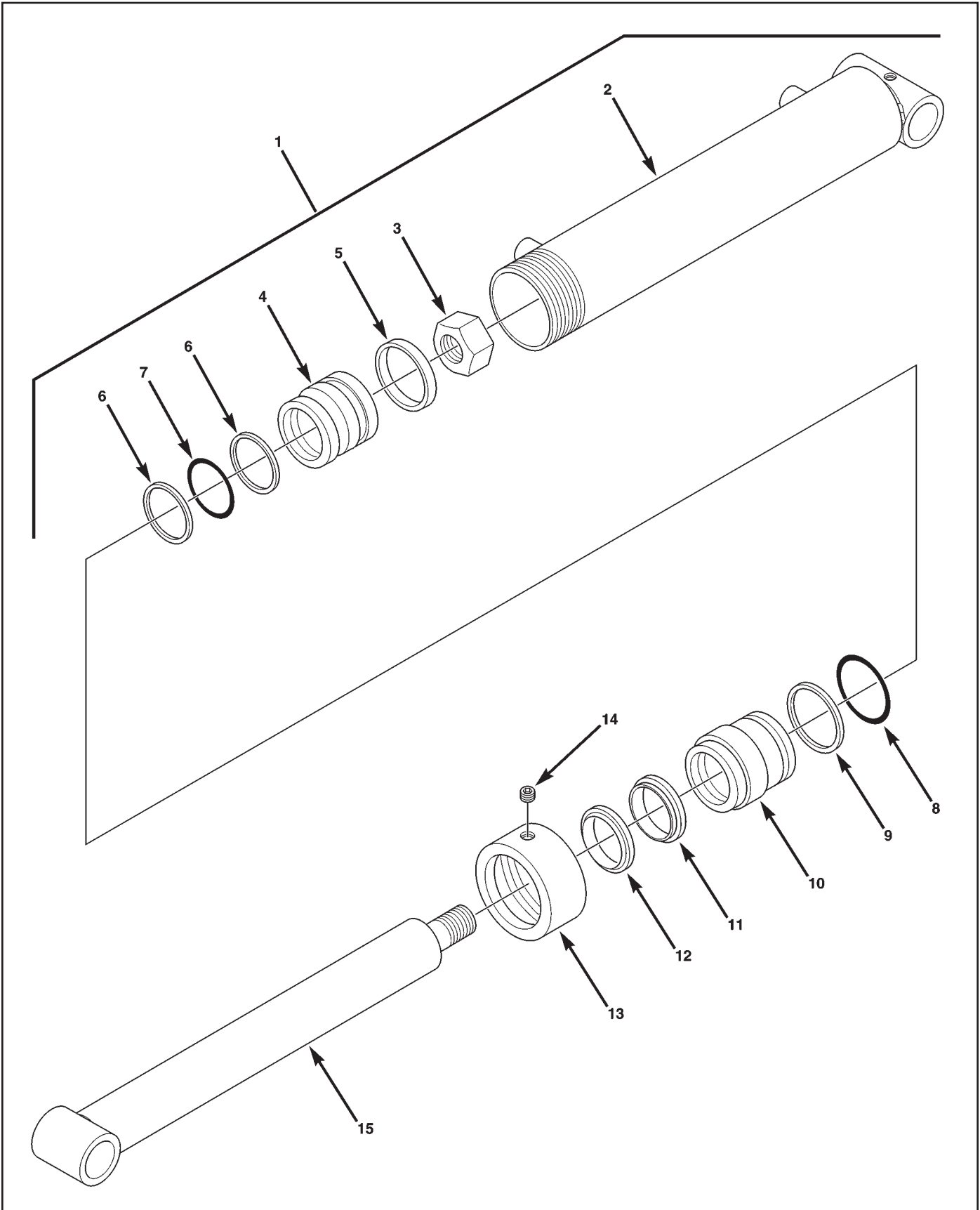

Grapple Kit Model GK-6078

PARTS LIST



New Holland, PA 17557
 Phone (717) 354-8721 • FAX (717) 354-2162
 1-800-342-0905
 www.preseeder.com

Figure 9. Cylinder Assembly

Item	Part No.	Qty	Description
1	000-166-097	1	Cylinder Assembly, Right Hand, 1-3/4" Bore x 6" Stroke (Not Shown)
	000-166-080	1	Cylinder Assembly, Left Hand, 1-3/4" Bore x 6" Stroke (Shown)
			Includes Items 2 thru 15
2	000-166-131	1	Barrel Assembly, Right Hand (Not Shown)
	000-166-086	1	Barrel Assembly, Left Hand (Shown)
3	LP	1	Nut, Lock, 1/2"-20UNF
4	000-166-087	1	Piston
5	NSS	1	Uniring
6	NSS	2	Ring, Back Up
7	NSS	1	O-Ring
8	NSS	1	O-Ring
9	NSS	1	Ring, Back Up
10	000-166-088	1	Head, Threaded Cap
11	NSS	1	U-Cup, Loaded
12	NSS	1	Wiper, Rod
13	000-166-089	1	Cap, Threaded
14	LP	1	Screw, Set, 1/4"-20UNC x 1/4" Long
15	000-166-090	1	Rod Assembly
	000-166-085	AR	Kit, Cylinder Repair Includes: Items 5 thru 9, 11 & 12

AR - As Required NSS - Not Serviced Separately ASN - After Serial No. BSN - Before Serial No. LP - Local Purchase