



OPERATOR'S AND PARTS MANUAL



PALADIN
LIGHT CONSTRUCTION GROUP



The Power of Combined Excellence

BALE HUGGER

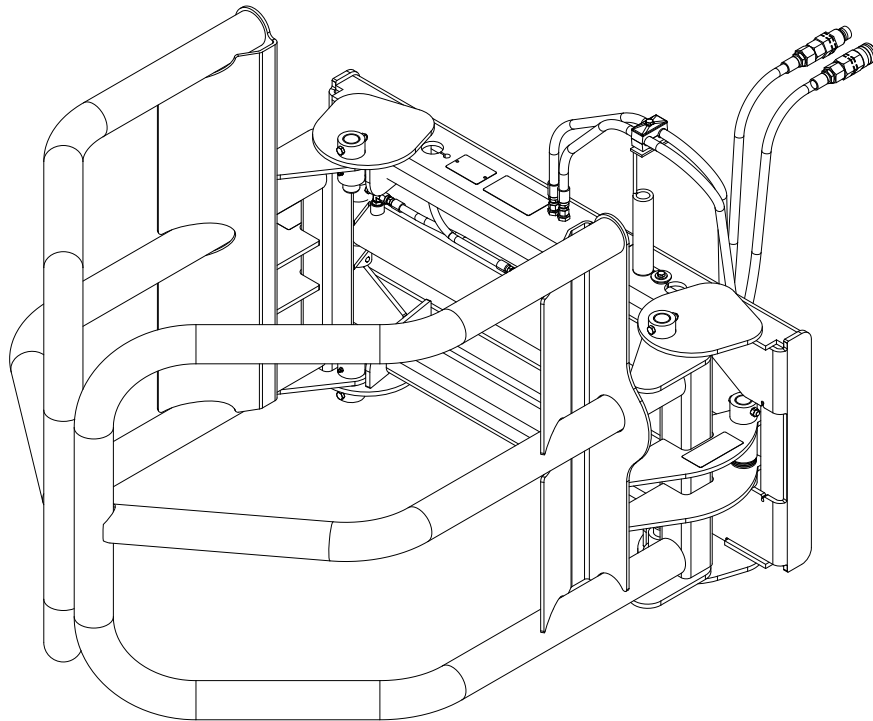

SERIAL NUMBER: _____

MODEL NUMBER: _____

Manual Number: MR25616
Part Number: LAF1960
Rev. 2

TABLE OF CONTENTS

INTRODUCTION	3
GENERAL INFORMATION	3
SERIAL NUMBER	3
OWNER AND OPERATOR SAFETY INFORMATION	
SAFETY STATEMENTS	4
SAFETY PRECAUTIONS	4-7
SAFETY SIGNS	8-9
SPECIFICATIONS	10-11
MOUNTING	12
HYDRAULIC CONNECTION	13
OPERATION	14
MAINTENANCE	15
PARTS ILLUSTRATION	16
PARTS LIST	17
HYDRAULIC CYLINDER PARTS ILLUSTRATION & LIST	18
WARRANTY	i

INTRODUCTION

Congratulations on your purchase of a new FFC Bale Squeeze. This product has been designed and built to lift, transport, and stack round or rectilinear bales of organic materials. You or any other person who will be assembling, operating, maintaining, or working with this product are required to read and completely understand the information and instructions contained in this manual. If anyone does not fully understand every part of this manual, please obtain further assistance by contacting the dealer from which this product was purchased or by contacting FFC at the telephone number or address listed on the cover of this manual. Keep this manual available for reference whenever this product is being handled or used. Provide this manual to any new owners and/or operators. This manual covers model: **LAF1960**.

GENERAL INFORMATION

The purpose of this manual is to assist in assembling, mounting, operating, and maintaining your attachment. Read this manual carefully to obtain valuable information and instructions that will help you achieve years of safe and dependable service.

The illustrations and data used in this manual were current at the time of printing, but due to possible engineering and/or production changes, this product may vary slightly in detail. FFC reserves the right to redesign and/or change components as may be necessary without notification to anyone.

Throughout this manual, references may be made to:

Prime Mover	The engine-driven machine to which this product must be attached.
Right, Left, Front, Rear	Directions that are determined in relation to the operator of the equipment when seated in the normal operation position.
IMPORTANT	Precautions that must be followed to prevent substandard performance.

SERIAL NUMBER LOCATION

Always refer to the model and serial number when ordering parts or requesting information from your dealer. See Safety Signs section for the location of the serial number plate for this product.

Reference Information	
Model Number	Prime Mover Make & Model
Serial Number	Loader Model
Date Purchased	Loader Serial Number

SAFETY STATEMENTS



THIS SYMBOL BY ITSELF OR WITH A WARNING WORD THROUGHOUT THIS MANUAL IS USED TO CALL YOUR ATTENTION TO INSTRUCTIONS INVOLVING YOUR PERSONAL SAFETY OR THE SAFETY OF OTHERS. FAILURE TO FOLLOW THESE INSTRUCTIONS CAN RESULT IN INJURY OR DEATH.



DANGER

THIS SIGNAL WORD IS USED WHERE SERIOUS INJURY OR DEATH WILL RESULT IF THE INSTRUCTIONS ARE NOT FOLLOWED PROPERLY.



WARNING

THIS SIGNAL WORD IS USED WHERE SERIOUS INJURY OR DEATH COULD RESULT IF THE INSTRUCTIONS ARE NOT FOLLOWED PROPERLY.



CAUTION

THIS SIGNAL WORD IS USED WHERE MINOR INJURY COULD RESULT IF THE INSTRUCTIONS ARE NOT FOLLOWED PROPERLY.

NOTICE

NOTICE INDICATES A PROPERTY DAMAGE MESSAGE.

GENERAL SAFETY PRECAUTIONS

WARNING! READ MANUAL PRIOR TO INSTALLATION



Improper installation, operation, or maintenance of this equipment could result in serious injury or death. Operators and maintenance personnel should read this manual, as well as all manuals related to this equipment and the prime mover thoroughly before beginning installation, operation, or maintenance. **FOLLOW ALL SAFETY INSTRUCTIONS IN THIS MANUAL AND THE PRIME MOVER'S MANUAL(S).**



READ AND UNDERSTAND ALL SAFETY STATEMENTS

Read all safety decals and safety statements in all manuals prior to operating or working on this equipment. Know and obey all OSHA regulations, local laws, and other professional guidelines for your operation. Know and follow good work practices when assembling, maintaining, repairing, mounting, removing, or operating this equipment.



KNOW YOUR EQUIPMENT

Know your equipment's capabilities, dimensions and operations before operating. Visually inspect your equipment before you start, and never operate equipment that is not in proper working order with all safety devices intact. Check all hardware to ensure it is tight. Make certain that all locking pins, latches, and connection devices are properly installed and secured. Remove and replace any damaged, fatigued, or excessively worn parts. Make certain all safety decals are in place and are legible. Keep decals clean, and replace them if they become worn and hard to read.

GENERAL SAFETY PRECAUTIONS

WARNING! PROTECT AGAINST FLYING DEBRIS



Always wear proper safety glasses, goggles or a face shield when driving pins in or out, or when any operation causes dust, flying debris, or any other hazardous material.

WARNING! LOWER OR SUPPORT RAISED EQUIPMENT



Do not work under raised booms without supporting them. Do not use support material made of concrete blocks, logs, buckets, barrels or any other material that could suddenly collapse or shift positions. Make sure support material is solid, not decayed, warped, twisted, or tapered. Lower booms to ground level or onto blocks. Lower booms and attachments to the ground before leaving the cab or operator's station.

WARNING! USE CARE WITH HYDRAULIC FLUID PRESSURE



Hydraulic fluid under pressure can penetrate the skin and cause serious injury or death. Hydraulic leaks under pressure may not be visible. Before connecting or disconnecting hydraulic hoses, read your prime movers operator's manual for detailed instructions on connecting and disconnecting hydraulic hoses or fittings.

- Keep unprotected body parts, such as face, eyes, and arms as far away as possible from a suspected leak. Flesh injected with hydraulic fluid may develop gangrene or other permanent disabilities.
- If injured by injected fluid, see a doctor at once. If your doctor is not familiar with this type of injury, ask him to research immediately to determine proper treatment.
- Wear safety glasses, protective clothing, and use a sound piece of cardboard or wood when searching for hydraulic leaks. **DO NOT USE YOUR HANDS!** **SEE ILLUSTRATION.**

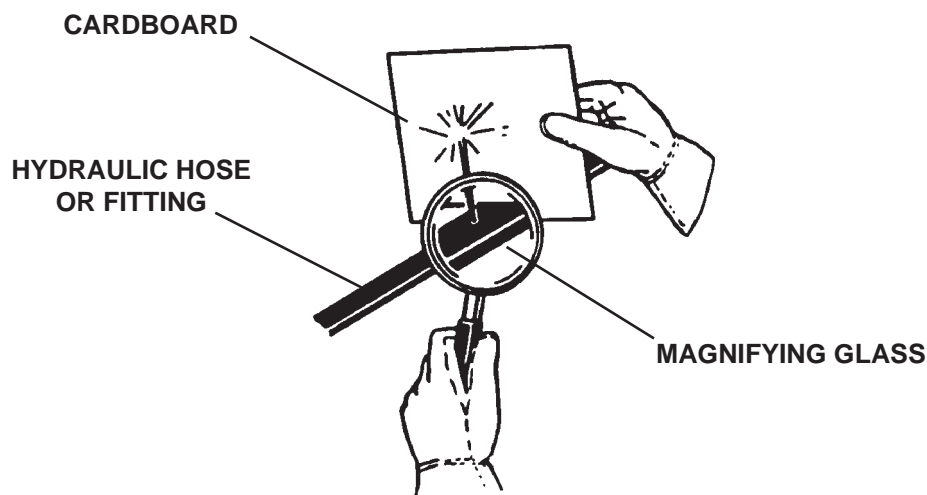

GENERAL SAFETY PRECAUTIONS

WARNING! DO NOT MODIFY MACHINE OR ATTACHMENTS



Modifications may weaken the integrity of the attachment and may impair the function, safety, life, and performance of the attachment. When making repairs, use only the manufacturer's genuine parts, following authorized instructions. Other parts may be substandard in fit and quality. Never modify any ROPS (Roll Over Protection Structure) or FOPS (Falling Object Protective Structure) equipment or device. Any modifications must be authorized in writing by the manufacturer.

WARNING! SAFELY MAINTAIN AND REPAIR EQUIPMENT



- Do not wear loose clothing, or any accessories that can catch in moving parts. If you have long hair, cover or secure it so that it does not become entangled in the equipment.
- Work on a level surface in a well-lit area.
- Use properly grounded electrical outlets and tools.
- Use the correct tool for the job at hand. Make sure they are in good condition for the task required.
- Wear the protective equipment specified by the tool manufacturer.

WARNING! SAFELY OPERATE EQUIPMENT



Do not operate equipment until you are completely trained by a qualified operator in how to use the controls, know its capabilities, dimensions, and all safety requirements. See your machine's manual for these instructions.

- Keep all step plates, grab bars, pedals, and controls free of dirt, grease, debris, and oil.
- Never allow anyone to be around the equipment when it is operating.
- Do not allow riders on the attachment or the prime mover.
- Do not operate the equipment from anywhere other than the correct operators position.
- Never leave equipment unattended with the engine running or with this attachment in a raised position.
- Do not alter or remove any safety feature from the prime mover or this attachment.
- Know your work site safety rules as well as traffic rules and flow. When in doubt on any safety issue, contact your supervisor or safety coordinator for an explanation.

WARNING! KNOW WHERE UTILITIES ARE



Observe overhead electrical and other utility lines. Be sure equipment will clear them. When digging, call your local utilities for location of buried utility lines, gas, water, and sewer, as well as any other hazard you may encounter.

EQUIPMENT SAFETY PRECAUTIONS

WARNING!  Obey all the safety instructions listed in this section and throughout this manual. Failure to obey instructions in this section may result in death or serious injury.

- NEVER HANDLE MORE THAN ONE BALE AT A TIME.
- Do not fully raise the loader and roll back this product. The bale could slip out of the grasp of the squeeze arms and fall on the operator or a bystander.
- When the prime mover is moving forward, do not hydraulically change the squeeze arms. The bale could fall in the path of the prime mover and could cause loss of control or tipping of the prime mover.

SAFETY SIGN LOCATIONS

The diagram on this page shows the location of the decals used of the FFC Bale Squeeze. The decals are identified by their part numbers, with reductions of the actual decals located on the following page. Use this information to order replacements for lost or damaged decals. Be sure to read all decals before operating the attachment. They contain information you need to know for both safety and product longevity.

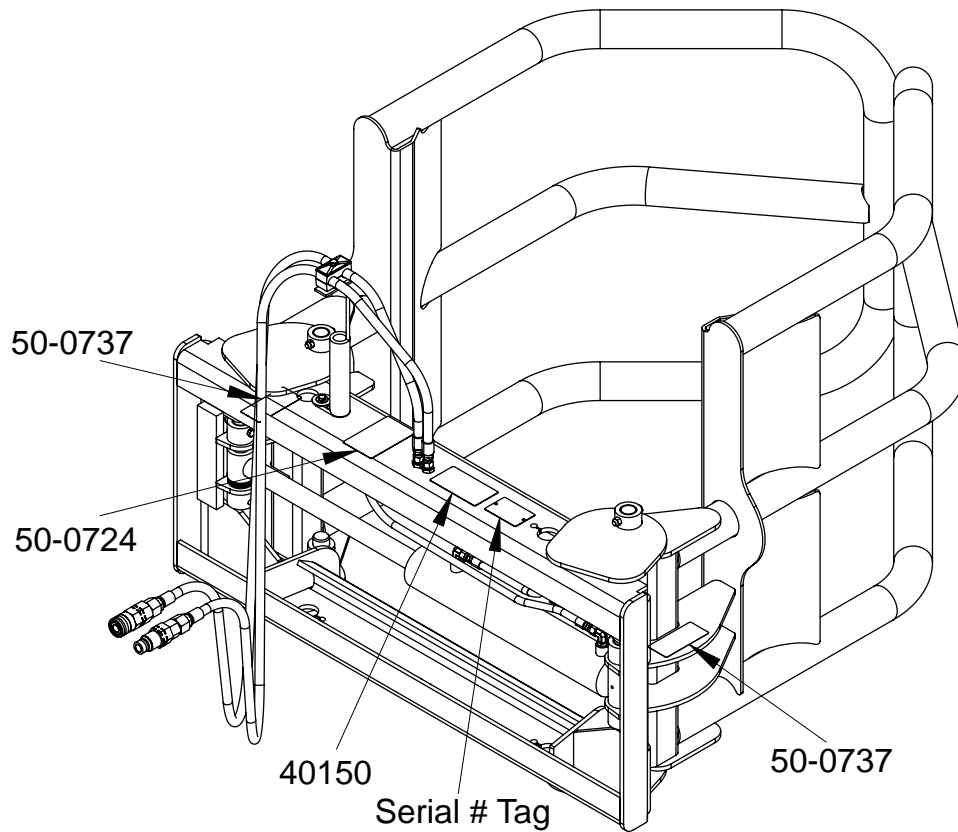

INSTRUCTIONS

- Keep all safety signs clean and legible.
- Replace all missing, illegible, or damaged safety signs.
- Replacement parts for parts with safety signs attached must also have safety signs attached.
- Safety signs are available, free of charge, from your dealer or from FFC.

PLACEMENT OR REPLACEMENT OF SAFETY SIGNS

1. Clean the area of application with non-flammable solvent, and then wash the same area with soap and water.
2. Allow the surface to fully dry.
3. Remove the backing from the safety sign, exposing the adhesive surface.
4. Apply the safety sign to the position shown in the diagram above and smooth out any bubbles.

SAFETY SIGNS

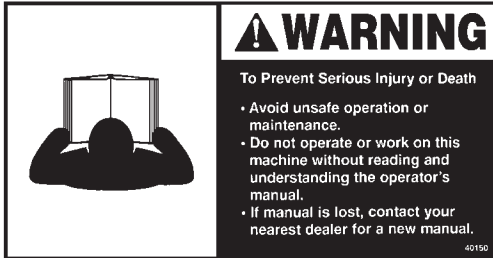

PART # 40150
WARNING! READ MANUAL



PART # 50-0724
WARNING! HIGH PRESSURE FLUID



PART # 50-0737
WARNING! PINCH POINT

PRIME MOVER/LOADER SPECIFICATIONS

IMPORTANT Exceeding any of the maximum recommended prime mover/loader specifications **CAN** result in damage to this product and **WILL** void all FFC warranties.

DESCRIPTION	SPECIFICATIONS
Operating Capacity of Prime Mover's loader	5,000 lbs. maximum
Lift Capacity of Prime Mover's loader	10,000 lbs. maximum
Hydraulic Pressure Output	3,000 psi. maximum
Rear Ballast	As required to maintain full prime mover stability. (Note the shipping weight of your model, then see the operator's manual(s) for your prime mover and loader, and quick attach for ballasting needs.)

ATTACHMENT SPECIFICATIONS

Model Number	Overall Width	Overall Height	Overall Depth	Shipping Weight
LAF1960	47.5"	37.5"	54"	480 lbs.

All replacement hydraulic hoses and fittings must have a minimum rated working pressure of 3,000 psi.

BOLT TORQUE

BOLT TORQUE SPECIFICATIONS

GENERAL TORQUE SPECIFICATION TABLES

Use the following charts when determining bolt torque specifications when special torques are not given. Always use grade 5 or better when replacing bolts.

SAE BOLT TORQUE SPECIFICATIONS

NOTE: The following torque values are for use with extreme pressure lubricants, plating or hard washer applications Increase torque 15% when using hardware that is unplated and either dry or lubricated with engine oil.

Bolt Size		SAE GRADE 5 TORQUE				SAE GRADE 8 TORQUE				Bolt head identification marks as per grade. NOTE: Manufacturing Marks Will Vary
		Pounds Feet		Newton-Meters		Pounds Feet		Newton-Meters		
Inches	Millimeters	UNC	UNF	UNC	UNF	UNC	UNF	UNC	UNF	
1/4	6.35	8	9	11	12	10	13	14	18	
5/16	7.94	14	19	19	23	20	25	27	34	
3/8	9.53	30	36	41	49	38	46	52	62	
7/16	11.11	46	54	62	73	60	71	81	96	
1/2	12.70	68	82	92	111	94	112	127	152	
9/16	14.29	94	112	127	152	136	163	184	221	
5/8	15.88	128	153	174	207	187	224	254	304	
3/4	19.05	230	275	312	373	323	395	438	536	
7/8	22.23	340	408	461	553	510	612	691	830	
1	25.40	493	592	668	803	765	918	1037	1245	
1-1/8	25.58	680	748	922	1014	1088	1224	1475	1660	
1-1/4	31.75	952	1054	1291	1429	1547	1700	2097	2305	
1-3/8	34.93	1241	1428	1683	1936	2023	2312	2743	3135	
1-1/2	38.10	1649	1870	2236	2535	2686	3026	3642	4103	

METRIC BOLT TORQUE SPECIFICATIONS

NOTE: The following torque values are for use with metric hardware that is unplated and either dry or lubricated with engine oil. Reduce torque 15% when using hardware that has extreme pressure lubricants, plating or hard washer applications.

Bolt head identification marks as per grade.		

Size of Bolt	Grade No.	Pitch (mm)	Pounds Feet	Newton-Meters	Pitch (mm)	Pounds Feet	Newton-Meters
M6	5.6	1.0	3.6-5.8	4.9-7.9	-	-	-
	8.8		5.8-4	7.9-12.7		-	-
	10.9		7.2-10	9.8-13.6		-	-
M8	5.6	1.25	7.2-14	9.8-19	1.0	12-17	16.3-23
	8.8		17-22	23-29.8		19-27	25.7-36.6
	10.9		20-26	27.1-35.2		22-31	29.8-42
M10	5.6	1.5	20-25	27.1-33.9	1.25	20-29	27.1-39.3
	8.8		34-40	46.1-54.2		35-47	47.4-63.7
	10.9		38-46	51.5-62.3		40-52	54.2-70.5
M12	5.6	1.75	28-34	37.9-46.1	1.25	31-41	42-55.6
	8.8		51-59	69.1-79.9		56-68	75.9-92.1
	10.9		57-66	77.2-89.4		62-75	84-101.6
M14	5.6	2.0	49-56	66.4-75.9	1.5	52-64	70.5-86.7
	8.8		81-93	109.8-126		90-106	122-143.6
	10.9		96-109	130.1-147.7		107-124	145-168
M16	5.6	2.0	67-77	90.8-104.3	1.5	69-83	93.5-112.5
	8.8		116-130	157.2-176.2		120-138	162.6-187
	10.9		129-145	174.8-196.5		140-158	189.7-214.1
M18	5.6	2.0	88-100	119.2-136	1.5	100-117	136-158.5
	8.8		150-168	203.3-227.6		177-199	239.8-269.6
	10.9		175-194	237.1-262.9		202-231	273.7-313
M20	5.6	2.5	108-130	146.3-176.2	1.5	132-150	178.9-203.3
	8.8		186-205	252-277.8		206-242	279.1-327.9
	10.9		213-249	288.6-337.4		246-289	333.3-391.6

BALE SQUEEZE MOUNTING

WARNING! READ MANUAL PRIOR TO INSTALLATION



Improper installation, operation, or maintenance of this equipment could result in serious injury or death. Operators and maintenance personnel should read this manual, as well as all manuals related to this equipment and the prime mover/loader thoroughly before beginning installation, operation, or maintenance. **FOLLOW ALL SAFETY INSTRUCTIONS IN THIS MANUAL AND THE PRIME MOVER'S MANUAL(S).**

1. Place this product on a firm, level surface that is large enough to safely accommodate this product, your prime mover, and all workers involved in the mounting process.
2. Refer to the operator's manual(s) for your prime mover, loader, and quick-attach and follow the mounting instructions contained therein.
3. Carefully raise the loader and cycle the tilt cylinders to check clearances and to verify that all mounting procedures have been successfully completed.

IMPORTANT

Lubricate all grease fittings before connecting this product to your prime mover's hydraulic system.
Refer to BALE SQUEEZE MAINTENANCE and follow the instructions.

HYDRAULIC CONNECTION



READ AND UNDERSTAND ALL SAFETY STATEMENTS

Read all safety decals and safety statements in all manuals before beginning any Bale Squeeze hydraulic connection. Know and obey all OSHA regulations, local laws, and other professional guidelines for your operation. Know and follow good work practices when assembling, maintaining, repairing, mounting, removing, or operating this equipment.

1. You must purchase and install two hydraulic hoses that have fittings permanently attached to each end. These hoses and fittings must meet the following specifications: (NOTE: If your Bale Squeeze was supplied with hoses, skip to step 4.)
 - Inside Diameter:..... 0.38"
 - Minimum Operating Pressure:..... 3,500 psi.
 - Hose End Fittings:..... One hose end must be a #6 female JIC fitting. The fitting for the other end can be whatever you determine to be the most beneficial to making the connection to your prime mover.
 - Length:..... You must make this determination based upon recommendations provided in your prime mover's operator's manual. The hoses must be long enough to avoid applying any tension to them (i.e. stretching) in all operating positions of this product. The hoses must not be excessively long either, because this could cause the hoses to drag on the ground, be pinched in the equipment, become entangled in moving parts, etc., any of which will shorten the life of the hose and could cause injury to the operator or others near the equipment.
2. Remove all the protective plastic caps from the hose ends and this product's connection fittings.
3. Make certain that the male and female threads, as well as the inside of the hoses, are clean, then place the #6 hose ends on/in to the fittings on this product and tighten to 27 ft. lbs., + or - 2.0 ft. lbs. (#6 is .56" dia. with 18 tpi.)
4. Make the connection to your prime mover using the appropriate method below for your prime mover:
 - If your prime mover has male or female threads for connecting the hydraulic hoses to the auxiliary hydraulic lines, make certain that threads, as well as the inside of the fittings and hoses are clean, then secure the hoses to the fittings using the torque specified in your prime mover's operator's manual.
 - If your prime mover uses quick-couplers for connecting the hydraulic hoses to the auxiliary hydraulic lines, you may need to purchase the proper quick-coupler fittings that you must install on the free ends of the two hoses. In most cases, the owner's manual for your prime mover will describe the exact type of fitting that is needed for your hydraulic coupling system, but in no case should any fitting have an allowable operating pressure of less than 3,500 psi. Once all the quick-coupler fittings are properly installed, then the hoses can be coupled to the prime mover's hydraulic valve body or auxiliary hydraulic lines as per the instructions found in your prime mover's operator's manual.
5. Carefully raise the loader and cycle the tilt cylinders to check hose clearances and to check for any interference. Operate the hydraulic cylinder(s) on this product to make the same checks.
6. Cycle the hydraulic cylinder(s) on this product several times from fully retracted to fully extended until all air has been completely removed from the cylinder(s).

NOTICE: When shipped, the hydraulic cylinder(s) on this product contained air or an air-fluid mixture. Also, there are orifices beneath the port(s) in the hydraulic cylinder barrel(s) that will restrict the exit of that air. Failure to remove all the air from the hydraulic cylinder(s) can cause uneven, jerky cylinder movement when the hydraulic controls are being operated and unwanted cylinder movement when those controls are not being operated.

BALE SQUEEZE OPERATION



SAFETY FIRST!! READ AND UNDERSTAND THE SAFETY INSTRUCTIONS BEFORE BEGINNING ANY BALE SQUEEZE OPERATION

WARNING! Failure to obey the following procedures could result in death or serious injury.



- Never handle more than one [1] bale at a time.
- Do not fully raise the loader and roll back this product.
- When the prime mover is moving forward, do not hydraulically change the pivoting arms. The bale could fall in the path of the prime mover and cause loss of control or tipping of the prime mover.

IMPORTANT Using this product to lift any inorganic objects **CAN** result in damage to this product and **WILL** void all FFC warranties.

IMPORTANT Lifting more than 2,400 pounds of bales **CAN** result in damage to this product and **WILL** void all FFC warranties.

POSITIONING THE LOAD

1. Approach the bale so that the pivoting arms will contact the bale slightly below center and the mainframe just touches the bale.
2. Hydraulically bring the pivoting arms in using the full hydraulic capacity of your prime mover.
3. Roll back and lift the bale slightly and make sure that the bale is secure. If the bale appears to be unstable, lower the bale, and reposition the squeeze arms to achieve full stability. Repeat steps 2 and 3 until full stability is achieved.

TRANSPORTING THE LOAD

1. Raise the load to the **minimum** height required for the terrain that must be crossed with the bale.
2. Operate your prime mover so that:
 - the bale always remains close to the ground,
 - accelerating, turning, and braking are done very gradually,
 - and any obstacles, bumps, or holes in your intended path are avoided.
3. Maintain visual contact with the bale to make sure that the bale remains stable.

MAINTENANCE



KNOW YOUR EQUIPMENT

Know your equipment's capabilities, dimensions and operations before operating. Visually inspect your equipment before you start, and never operate equipment that is not in proper working order with all safety devices intact. Check all hardware to ensure it is tight. Make certain that all locking pins, latches, and connection devices are properly installed and secured. Remove and replace any damaged, fatigued, or excessively worn parts. Make certain all safety decals are in place and are legible. Keep decals clean, and replace them if they become worn and hard to read.

BEFORE EACH USE

- Make sure that all nuts and bolts are in place and properly tightened.
- Make sure that all other fasteners are in place and are performing their specified function.
- Make sure that all hydraulic fittings are tightened and that there are no leaks in any fittings or hoses.
- Make sure that all safety signs are in place, are clean, and are legible.
- Replace any damaged parts and excessively worn parts.

AFTER EVERY 10 HOURS OF USE

- Grease 6 fittings: two [2] on each pivoting arm weldment and one [1] on each cylinder.

IMPORTANT When replacing parts, use only factory approved replacement parts. Manufacturer will not claim responsibility for use of unapproved parts or accessories and/or other damages as a result of their use.

BALE SQUEEZE PARTS ILLUSTRATION

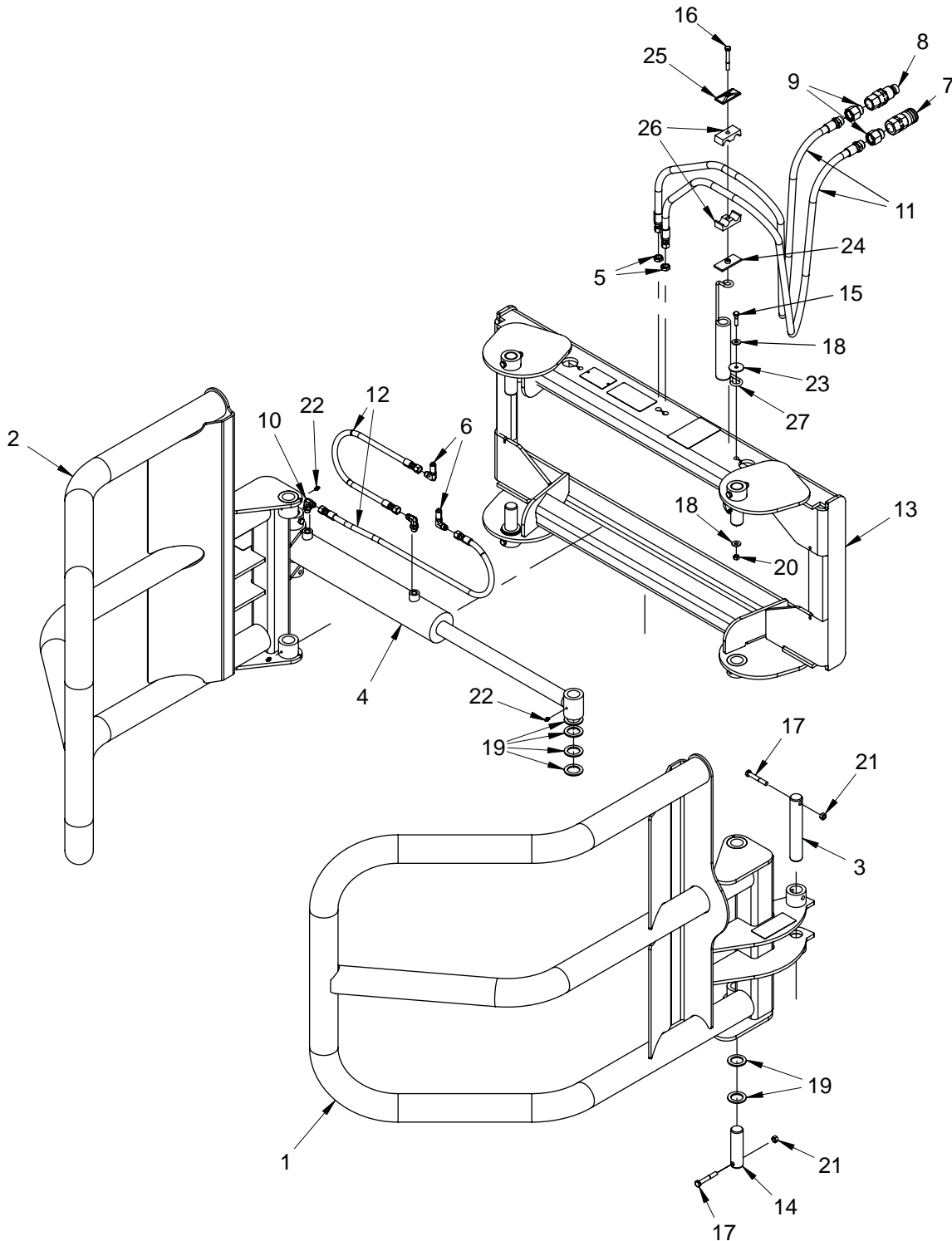

BALE SQUEEZE PARTS LIST

ITEM	QTY.	LAF1960	DESCRIPTION
1	1	13-51990	Left Arm Weldment
2	1	13-51991	Right Arm Weldment
3	2	LAF3098	Cylinder Pin 1.25" x 7.63"
4	1	LAF4044	Hydraulic Cylinder 3" x 1.5" x 16" (Cylinder Seal Kit = LAF4005)
5	2	3217	Jam Nut #6 Hydraulic Fitting (.56" Dia x 18 TPI)
6	2	3282	Bulkhead Fitting 90° #6MJ-#6MJ without nut
*7	1	22518	Hydraulic Hose Quick Coupler Female Connection
*8	1	19632	Hydraulic Hose Quick Coupler Male Connection
*9	2	30198	Adapter (not required on all models)
10	2	3434	Hydraulic Elbow 90° #6MJ-#6MB
*11	2	LAF4366	Hydraulic Hose .38" x 73" #6FJ-#10MB Sheathed
12	2	37421	Hydraulic Hose .25" x 25" #6FJ-#6FJ
13	1	LAF9438	Loader Attachment Weldment [Mainframe]
14	4	LAF9614	Pivot Pin 1.25" x 4.5"
15	1	1023	Hex Capscrew .31" x 1.25" Grade 5 (not required on all models)
16	1	1030	Hex Capscrew .31" x 3" Grade 5 (not required on all models)
17	6	1049	Hex Capscrew .38" x 2.5" Grade 5
18	2	1513	Flat Washer .31" Grade 5 (not required on all models)
19	8	RHW5972	Machine Bushing 1.25" ID - 1.88" OD
20	1	1753	Center Dent Lock Nut .31" Grade 5 (not required on all models)
21	6	1837	Center Dent Lock Nut .38" Grade 5
22	4	6616	Grease Zerk .25"
23	1	105840	Fender Washer .31" x 1.5" Grade 2 (not required on all models)
24	1	103184	Hose Clamp Plate (not required on all models)
25	1	103184	Hose Clamp Plate (not required on all models)
26	1	103181	Hose Cradle Set (not required on all models)
27	1	RHW8618	Hose Spring (not required on all models)

* Item may vary per Prime Mover -- Contact FFC for correct item.

HYDRAULIC CYLINDERS PARTS ILLUSTRATION & LIST

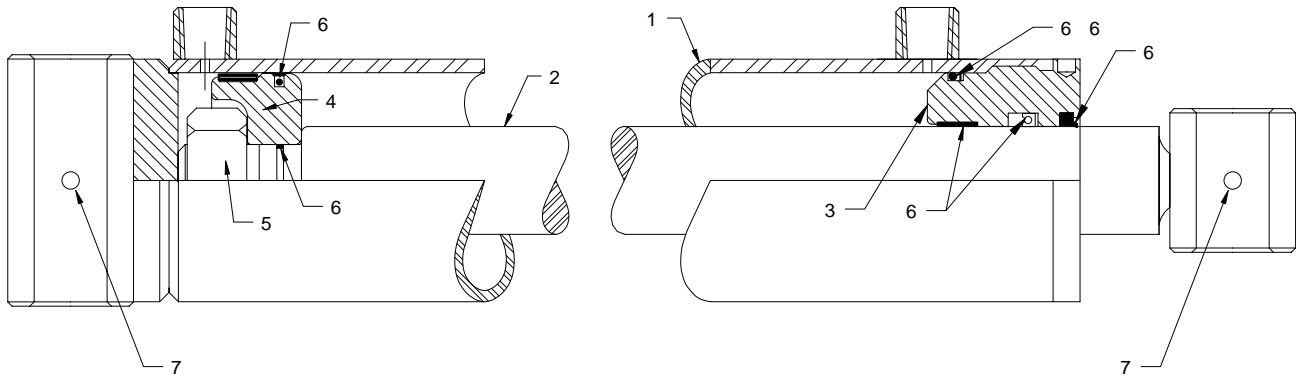

ITEM #	QTY.	LAF4044	DESCRIPTION
1	1	LAF4162	Barrel 3" ID x 16" Stroke with Cross Tube End
2	1	LAF4163	Shaft 1.5" Dia. with Cross Tube End
3	1	LAF4102	Head 1.5" ID Nominal
4	1	LAF4103	Piston 3" OD x 1.5" ID Nominal
5	1	LAF4104	Nut 1" Dia. 14-tpi Grade 8
6	1	LAF4005	Seal Kit (Includes all Seals, O-rings, etc.)
7	2	6616	Grease Zerk 1/4" 28 tpi Self-Tapping

Limited Warranty

Except for the Excluded Products as described below, all new products are warranted to be free from defects in material and/or workmanship during the Warranty Period, in accordance with and subject to the terms and conditions of this Limited Warranty.

1. Excluded Products. The following products are excluded from this Limited Warranty:

(a) Any cable, part that engages with the ground (i.e. sprockets), digging chain, bearing, teeth, tamping and/or demolition head, blade cutting edge, pilot bit, auger teeth and broom brush that either constitutes or is part of a product.

(b) Any product, merchandise or component that, in the opinion of Paladin Light Construction¹, has been (i) misused; (ii) modified in any unauthorized manner; (iii) altered; (iv) damaged; (v) involved in an accident; or (vi) repaired using parts not obtained through Paladin Light Construction.

2. Warranty Period. The Limited Warranty is provided only to those defects that occur during the Warranty Period, which is the period that begins on the first to occur of: (i) the date of initial purchase by an end-user, (ii) the date the product is first leased or rented, or (iii) the date that is six (6) months after the date of shipment by Paladin Light Construction as evidenced by the invoiced shipment date (the "Commencement Date") and ends on the date that is twelve (12) months after the Commencement Date.

3. Terms and Conditions of Limited Warranty. The following terms and conditions apply to the Limited Warranty hereby provided:

(a) Option to Repair or Replace. Paladin Light Construction shall have the option to repair or replace the product.

(b) Timely Repair and Notice. In order to obtain the Limited Warranty, (i) the product must be repaired within thirty (30) days from the date of failure, and (ii) a claim under the warranty must be submitted to Paladin Light Construction in writing within thirty (30) days from the date of repair.

(c) Return of Defective Part or Product. If requested by Paladin Light Construction, the alleged defective part or product shall be shipped to Paladin Light Construction at its manufacturing facility or other location specified by Paladin Light Construction, with freight PRE-PAID by the claimant, to allow Paladin Light Construction to inspect the part or product.

Claims that fail to comply with any of the above terms and conditions shall be denied.

LIMITATIONS AND EXCLUSIONS.

THIS LIMITED WARRANTY IS IN LIEU OF ALL OTHER WARRANTIES, EXPRESS OR IMPLIED, INCLUDING WITHOUT LIMITATION THE WARRANTIES OF MERCHANTABILITY, FITNESS FOR A PARTICULAR PURPOSE AND ANY WARRANTY BASED ON A COURSE OF DEALING OR USAGE OF TRADE.

IN NO EVENT SHALL PALADIN LIGHT CONSTRUCTION BE LIABLE FOR CONSEQUENTIAL OR SPECIAL DAMAGES.

IN NO EVENT SHALL PALADIN LIGHT CONSTRUCTION BE LIABLE FOR ANY LOSS OR CLAIM IN AN AMOUNT IN EXCESS OF THE PURCHASE PRICE, OR, AT THE OPTION OF PALADIN LIGHT CONSTRUCTION, THE REPAIR OR REPLACEMENT, OF THE PARTICULAR PRODUCT ON WHICH ANY CLAIM OF LOSS OR DAMAGE IS BASED. THIS LIMITATION OF LIABILITY APPLIES IRRESPECTIVE OF WHETHER THE CLAIM IS BASED ON BREACH OF CONTRACT, BREACH OF WARRANTY, NEGLIGENCE OR OTHER CAUSE AND WHETHER THE ALLEGED DEFECT IS DISCOVERABLE OR LATENT.

¹Attachment Technologies Inc., a subsidiary of Paladin Brands Holding, Inc. (PBHI) is referred to herein as Paladin Light Construction.

