

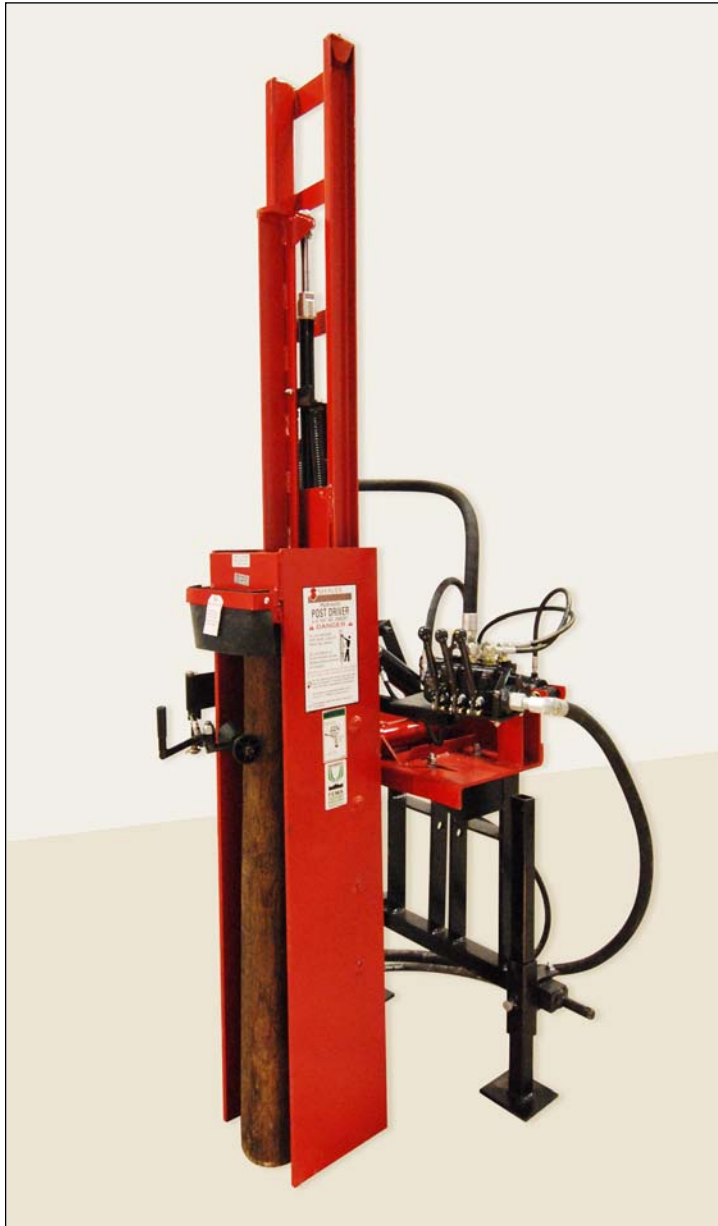

Operator's Manual



Hydraulic Post Driver

Model HD-12-H

Safety

Operation

Maintenance

Repair

Troubleshooting

Parts

Contents

Safety	2
Safety Alert Symbols	3
Safety Icon Nomenclature	3
Safety Warnings	4
General Safety	4
Hazard Avoidance	4
Hydraulic Hoses	5
Introduction	6
Product Information	6
Specifications	6
Assembly Procedure	7
Recommended Tools	7
Unpacking	8
Assembly	8
Main Carriage Channel	9
Stabilizer Legs	10
Base Plate	10
Hydraulic Valve	13
Safety Stop Adjustment	16
Rubber Debris Guard	17
Safety Arm	18
Document Storage Tube	21
Post Driver Operation	21
Operational Safety Tips	21
Operating Instructions	22
Mounting	22
Preparing to Drive a Post	23
Driving a Post	24
Dismounting Post Driver	28
Troubleshooting	29
Storage	29
Service Procedures	30
Three-Point Hitch/Post Driver Assembly	30
Main Carriage Channel Disassembly	31
Drive Cylinder Seal Replacement	34
Main Carriage Channel Assembly	36
Forward and Side Tilt Cylinder Maintenance	40
Cylinder Disassembly	40
Cylinder Assembly	41
Three-Point Hitch/Post Driver Assembly	43

Service Parts	44
Driver Assembly	44
Hydraulic Base Plate Assembly	46
Three-Point Hitch Assembly	48
Hydraulic Hoses	48
Safety Arm Assembly	48
Replacement Decals	49
Document Storage Tube	49
Hydraulic Control Valve	50
Drive Cylinder Assembly	51
Expanded View of Safety Lever Assembly	51
Tilt Cylinder Assembly	52
Limited Warranty	53
Warranty Card	54

Safety

Most work related accidents are caused by failure to observe basic safety rules or precautions. An accident can often be avoided by recognizing potentially hazardous situations before an accident occurs. As you assemble and operate the Shaver Post Driver, you must be alert to potential hazards. You should also have the necessary training, skills, and tools to perform this assembly procedure.

Improper operation and maintenance of this implement could result in a dangerous situation that could cause injury or death.

Do not assemble, operate, or maintain the Shaver Post Driver until you read and understand the information contained in this manual.



Safety precautions and warnings are provided in this manual and on the product. If these hazard warnings are not heeded, bodily injury or death could occur to you or to other persons.

Shaver Manufacturing Company cannot anticipate every possible circumstance that might involve a potential hazard. The warnings in this supplement and on the product are, therefore, not all-inclusive. If a method of operation, not specifically recommended by Shaver Manufacturing Company is used, you must satisfy yourself that it is safe for you and for others. You should also ensure that the implement will not be damaged or be made unsafe by the methods that you choose.

The information, specifications, and illustrations in this supplement are based on the information that was available at the time this material was written and can change at any time.

Safety Alert Symbols

 The safety alert symbol means **Attention! Become Alert! Your Safety is Involved.**

Hazards are identified by the “Safety Alert Symbol” and are followed by the signal word “WARNING”.

WARNING























WARNING: Indicates a potentially hazardous situation which, if not avoided, could result in death or serious injury.

Potential damage situations are identified by the signal words “*IMPORTANT NOTICE*”.

IMPORTANT NOTICE

Indicates that equipment or property damage can result if instructions are not followed.

Safety Icon Nomenclature

-  Read the manual
-  Eye protection
-  Foot protection
-  Hand protection
-  Hearing protection
-  Inspect equipment
-  Two person operation
-  Warning decal alert
-  Bending hazard (hydraulic hose)
-  Crushing hazard
-  Crushing hazard (hand)
-  Do not weld
-  Electrocution hazard
-  Explosion hazard
-  High-pressure fluid hazard
-  Impact hazard (hydraulic hose)
-  Pressurized fluid
-  Projectile hazard (body)
-  Protective guards
-  Safety alert symbol
-  Slipping hazard
-  Tripping hazard

Safety Warnings

General Safety

WARNING



To avoid personal injury or death, carefully read and understand all instructions before attempting to assemble and/or operate the Post Driver. Do not operate or work on equipment unless you read and understand the instructions and warnings in this and all other applicable manuals. Contact Shaver Manufacturing Company, if any of the instructions provided are unclear or not understood. Proper care is your responsibility. Always follow all State and Federal health and safety laws and/or local regulations.



To help prevent personal injury, protective equipment must be worn during Post Driver assembly, operation, and maintenance. Personal protective equipment should include, but not be limited to, safety glasses, hearing protection, protective gloves, and steel toe footwear.



Personal injury can result from slips or falls. **DO NOT** leave tools or parts laying around the work area, and clean up all spilled fluids immediately.

Hazard Avoidance

WARNING



Inspect this equipment before each use. Make sure all hardware is tight. Always replace worn or damaged parts before use.



To avoid personal injury or death, do not operate the Post Driver by yourself. Always have another person to control the machine or power source.

WARNING



Make sure all decals are securely attached to the Post Driver and are legible at all times. Always read and understand all decals before working on or operating the Post Driver.



Make sure all lock-pins and transport supports are secured in place before transporting or storing the Post Driver. While transporting, never ride on or permit others to ride on the Post Driver.



Improper operating procedures can create risk for the operator and bystanders. **DO NOT** use the Post Driver before making sure no one will be endangered.



To prevent personal injury or death, be aware of overhead electrical lines when operating the Post Driver. Electrocutation can occur even without direct contact with overhead power lines. Proceed cautiously around electrical lines and utility poles.



To prevent personal injury or death, always check for underground utilities, such as electrical wires, gas lines, and water pipes, before driving posts. Contact local utility companies for information on locating underground utilities.



To avoid serious injury or death, do not operate the Post Driver on steep slopes, as this can cause a roll over.



To avoid personal injury, always stand 45 degrees to the right of the post being driven while operating the Post Driver.

! WARNING



Potential pinch points. Keep hands clear of Post Driver while operating. Never place hand(s) on top of a post when inserting it into the Post Driver. Always close the safety arm before driving the post.



To avoid personal injury do not attempt to clean, adjust, or lubricate the Post Driver while it is in motion.



The rubber debris guard helps shield the operator from flying debris that may be generated during post driving. To avoid personal injury, make sure the rubber debris guard is securely attached to the Post Driver before driving posts.



To avoid personal injury or death, do not modify the Post Driver by welding, drilling, or grinding. Do not expose to extreme heat, such as from a torch.



The main carriage channel assembly is tall and heavy. To avoid tip over, resulting in serious injury or death, leave the overhead lifting device attached to the main carriage channel while assembling components.



The safety arm is spring loaded. To avoid serious injury or death, the safety arm must be installed after the Post Driver has been mounted on a machine, or the freestanding Post Driver has been secured to prevent tipping.

Hydraulic Hoses

! WARNING



Avoid damaging hydraulic hoses. Avoid sharp bends and kinks when routing hydraulic hoses. Sharp bends and kinks can internally damage the hose, leading to premature hose failure, resulting in personal injury.

! WARNING



Do not drop heavy objects on hoses. A sharp impact may cause internal damage to the hose. Applying pressure to a damaged hose may cause it to rupture, resulting in personal injury.

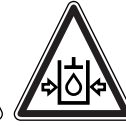

Mismatched couplings and hoses can cause the coupling to violently disconnect from the hose when placed under pressure; separating with sudden, extreme force which can result in property damage, personal injury, or death.

Replace a hose if any of the following conditions are present:

- End fittings that are damaged or leaking
- Outer coverings that are chafed or cut
- Wire shields that are exposed
- Outer coverings that are ballooning
- Flexible part of the hoses that are kinked
- End fittings that are displaced



Pressure can be trapped in a hydraulic system. Trapped pressure can cause sudden movement of an attachment. Use caution when disconnecting hydraulic lines or fittings. High-pressure oil that is released can cause a hose to move violently while spraying oil.



Escaping high-pressure fluid can penetrate the skin, causing serious injury. Relieve pressure before unhooking hoses. Check/tighten all connections before activating hydraulics. Never use your hand to check for leaks.

Introduction

The Shaver Manufacturing Company would like to congratulate you on your purchase of the Shaver Hydraulic Post Driver. You have selected the best Post Driver in its class. The clean design and uncomplicated working principle have made Shaver the largest selling Post Driver in the country.

The Shaver HD-12-H (hydraulic tilt adjustment) Hydraulic Post Driver is a durable piece of equipment that, with regular maintenance, will provide many years of service.

This manual provides information regarding assembly, operation, and maintenance. It is important to read and become familiar with this manual before assembling or operating the Shaver Hydraulic Post Driver.

NOTE: For other valuable information on farm equipment operation and safety, refer to the following resources.

- **Farm Equipment Manufacturers Association (FEMA)**
<http://www.farmequip.org/home>
- **National Ag Safety Database**
<http://www.cdc.gov/nasd>

Product Information

Record Shaver product information here. The model number and serial number are found on the metal tag attached to the drive ram.



Model Number _____

Serial Number _____

Date Purchased _____

Dealer Name _____

Specifications

HD-12-H Post Driver	
Approximate Length ¹	100 in (254 cm) collapsed 148 in (376 cm) extended
Approximate Width ²	44 in (111.8 cm)
Approximate Depth ²	38 in (96.5 cm)
Shipping Weight	975 lbs (442 kg)
Effective Weight of Spring Powered Driving Ram	1,100 lbs (499 kg)
Impact (at full stroke)	100,000 lbs (45,359 kg)
Main Carriage Channel	
Tilt Front/Back	20°/20°
Tilt Side/Side	25°/25°
Guide Blocks	8 (4 per side)
Mounting options	Tractor (rear) and skid steer
Three-Point Hitch	Category II and III
Hydraulic Requirements	15 GPM at 2000 PSI (45 LPM at 13,790 kPa)
Post Size	
Maximum Width	10.875 in (27.6 cm)
Maximum Length	10 ft (3.0 m)

¹ Driving ram and main carriage channel. Overall length will vary, depending on mounting position and tractor.

² With stabilizer legs attached to three point hitch weldment.

Assembly Procedure

Recommended Tools

The basic tools needed to assemble and maintain the HD-12-H Post Driver are shown below. Additional specialized tools may be required.

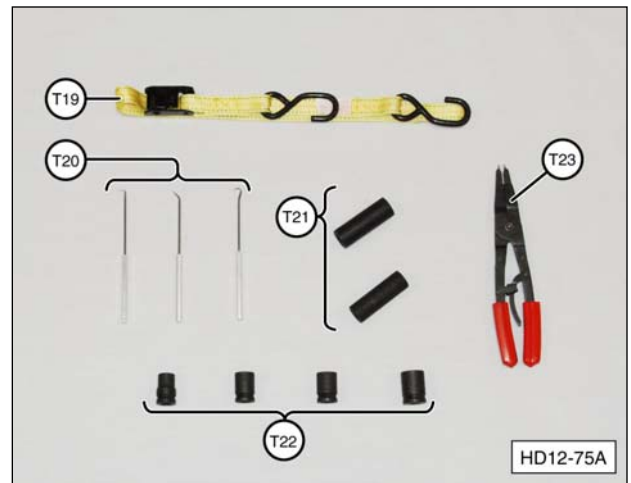
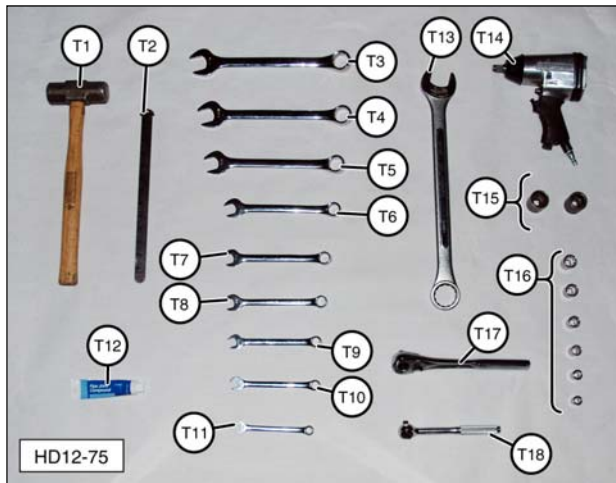

HD-12-H Recommended Tools		
No.	Description	Qty
T1	Mallet or Hammer	1
T2	Straight Edge	1
T3	1-1/8 Inch Combination Wrench	1
T4	1-1/16 Inch Combination Wrench	1
T5	15/16 Inch Combination Wrench	1
T6	3/4 Inch Combination Wrench	1
T7	11/16 Inch Combination Wrench	1
T8	5/8 Inch Combination Wrench	1
T9	9/16 Inch Combination Wrench	1
T10	1/2 Inch Combination Wrench	1
T11	7/16 Inch Combination Wrench	1
T12	Paste-Type Thread Sealant	AR
T13	1-1/2 Inch Combination Wrench	1
T14	1/2 Inch Drive Impact Gun	1
T15	1-1/2 Inch Impact Socket	1
	1-1/16 Inch Impact Socket	1
T16	3/8 and/or 1/2 Inch Drive Socket Set (9/16, 5/8, 11/16, 3/4, 15/16, 1 Inch)	AR
T17	1/2 Inch Drive Ratchet	1
T18	3/8 Inch Drive Ratchet	1

HD-12-H Recommended Tools (continued)		
No.	Description	Qty
T19	Heavy-Duty Retaining Strap	1
T20	Heavy-Duty Seal Picks ¹	AR
T21	9/16 Inch Deepwell Impact Socket	1
	1/2 Inch Deepwell Impact Socket	1
T22	9/16 Inch Impact Socket	1
	5/8 Inch Impact Socket	1
	11/16 Inch Impact Socket	1
	3/4 Inch Impact Socket	1
T23	Heavy-Duty Snap Ring Pliers ¹	1
—	Soft Brass or Wood Drift ¹ (not shown)	1

¹ Required for cylinder seal replacement.

AR - As Required

Unpacking

! WARNING



Due to the size and weight of the Post Driver, two people are required for the assembly procedures.

The Post Driver is shipped in several sections: the drive ram assembly, base plate assembly, short channel bracket, hose and valve carton, safety arm carton, and the tilt cylinder carton.

! WARNING



Before starting the unpacking procedure, make sure the overhead lifting device or material handling device (forklift) has adequate lifting capacity. Follow all safety recommendations when unpacking the Post Driver. Some components are heavy and can cause serious injury or death if not adequately supported during removal and assembly.

For ease of assembly, unload the Post Driver components in the area where they will be assembled. Choose a large, hard surface area that can safely support the weight of the assembled Post Driver and is accessible by the machine it will be mounted on.



Assembly

NOTE: Refer to the Service Parts section of this manual for a photograph and description of all the Post Driver parts.

The HD-12-H Post driver main carriage channel has provisions for mounting the short channel bracket in various positions. The HD-12-H is shipped with the short channel bracket bolts installed in the middle (most common) mounting position. If an optional mounting position is used, the three point hitch weldment and stabilizer leg height will have to be adjusted accordingly.

The Post Driver assembly procedure consists of the following subsections:

1. Main Carriage Channel
2. Stabilizer Legs (optional)
3. Base Plate
4. Hydraulic Valve
5. Safety Stop Adjustment
6. Rubber Debris Guard
7. Safety Arm
8. Document Storage Tube

Main Carriage Channel

1. With road lock pin (B8) installed in lower hole of drive ram (A1), use a suitable overhead lifting device to raise (stand up) main carriage channel (B1).

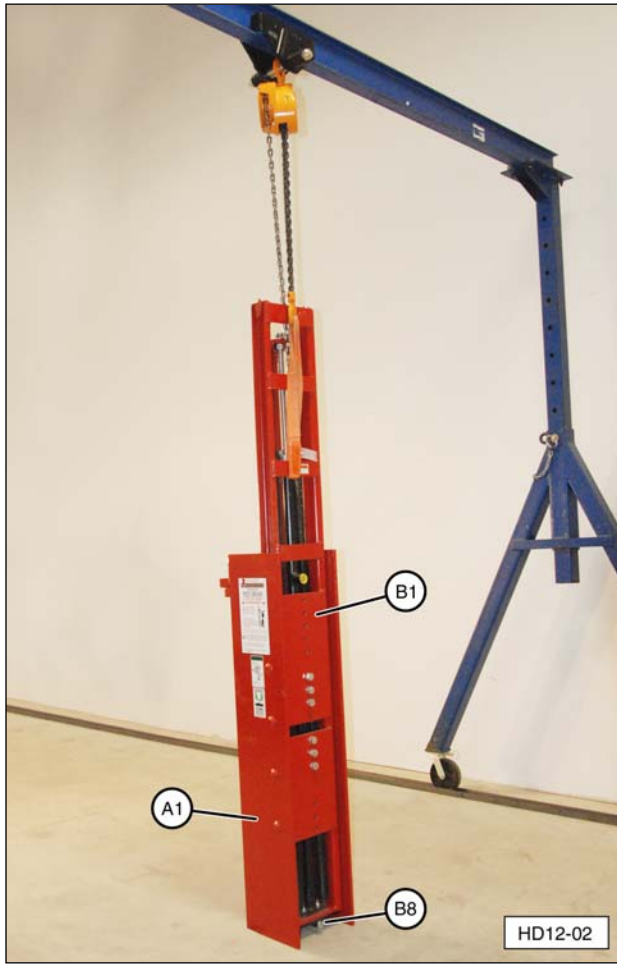

(A1) Drive Ram. (B1) Main Carriage Channel.
(B8) Road Lock Pin.

⚠ WARNING



The main carriage channel assembly is tall and heavy. To avoid tip over, resulting in serious injury or death, leave the overhead lifting device attached to the main carriage channel while assembling components.

2. Remove 6 factory installed bolts (D3) and 6 lock washers (D4). Install short channel bracket (D2) using the bolts and lock washers. Tighten bolts completely.

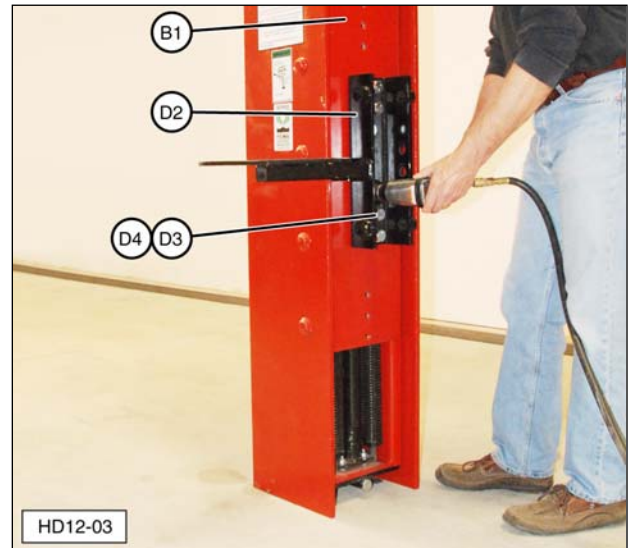

(A1) Drive Ram. (D2) Short Channel Bracket. (D3) Bolt.
(D4) Lock Washer.

3. Remove road lock pin (B8) from lower hole in drive ram (A1). Use the overhead lifting device to help raise main carriage channel (B1) and insert road lock pin (B8) in upper hole (tool storage position) in drive ram (A1). Install Lynch pin (B9), not shown, to secure the road lock pin.

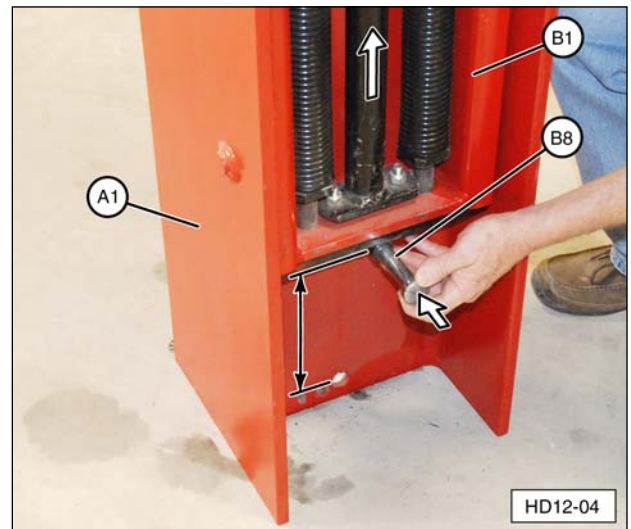

(A1) Drive Ram. (B1) Main Carriage Channel.
(B8) Road Lock Pin.

Stabilizer Legs (optional)

1. Place three-point hitch weldment (K1) upside down on the floor. Install stabilizer leg brackets (K2), with stabilizer legs (K7) installed, over the cross tube, as shown. Tighten two leg bracket bolts (K3) to secure the brackets to the cross tube.

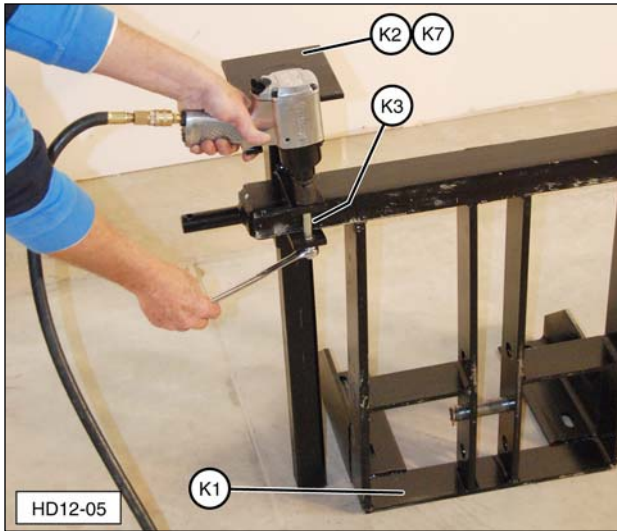

(K1) Three-Point Hitch Weldment. (K2) Leg Bracket.
(K3) Leg Bracket Bolt. (K7) Stabilizer Leg.

2. If the short channel bracket was mounted at the most common center position in Step 2, set stabilizer leg (K7) height at 8" (20.3 cm) measured from three-point hitch weldment (K1) cross tube to the stabilizer leg base plate, as shown. Tighten the stabilizer leg lock bolts.



(K1) Three-Point Hitch Weldment. (K2) Leg Bracket.
(K7) Stabilizer Leg.

NOTE: If a set of six threaded holes other than the center set, were used to mount short channel bracket (D2), the height of the legs will need to be adjusted accordingly.

3. Turn over three-point hitch weldment (K1) and set it on stabilizer leg (K7) base plates, as shown.

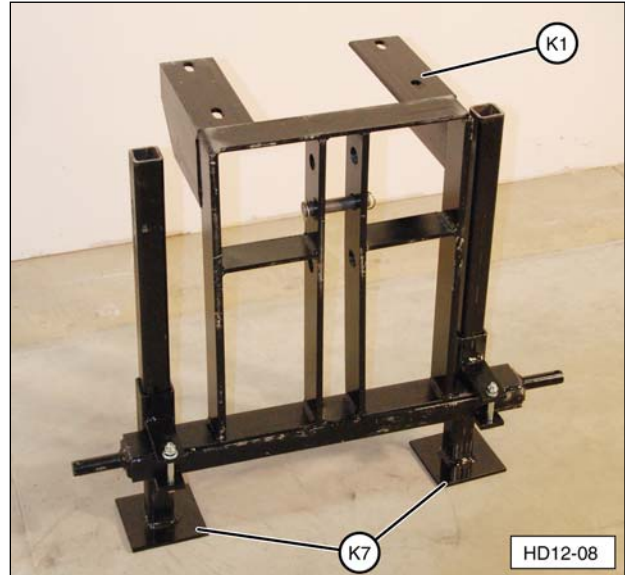

(K1) Three-Point Hitch Weldment. (K7) Stabilizer Legs.

Base Plate

1. Remove the four carriage bolts, washers, and nuts from base plate (F2). Save hardware for reuse.

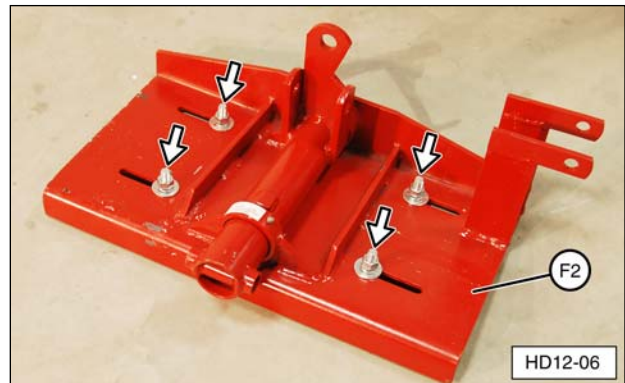

(F2) Base Plate.

⚠ WARNING



The main carriage channel assembly is tall and heavy. To avoid tip over, resulting in serious injury or death, leave the overhead lifting device attached to the main carriage channel while assembling components.

2. With three point hitch weldment (K1) positioned in front of short channel bracket (D2), install base plate (F2) as shown. Install the bolts, washers, lockwashers, and nuts removed in Step 1. Center the base plate on the three-point hitch weldment and tighten the hardware securely.

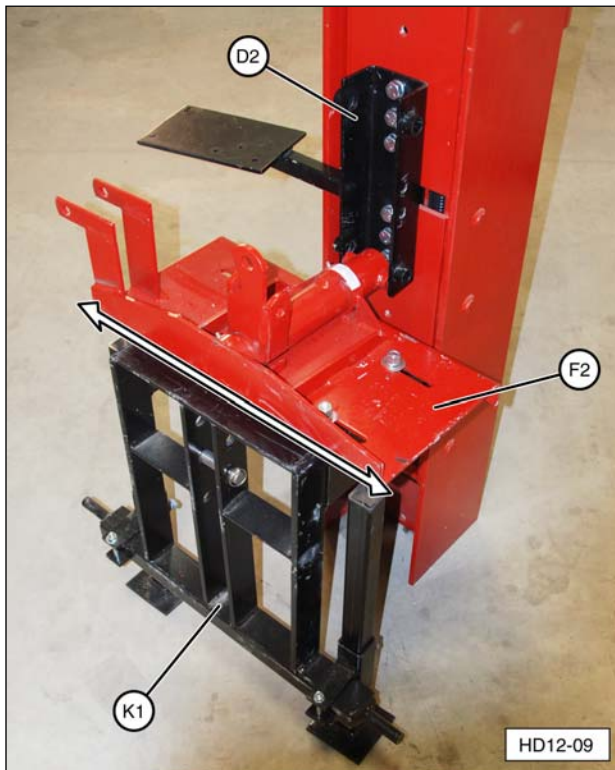

(D2) Short Channel Bracket. (F2) Base Plate.
(K1) Three-Point Hitch Weldment.

3. Install four hose assemblies (H5) on tilt cylinders (F3, F4) using paste-type thread sealant (T12) on fittings. Tighten the hose fittings securely.

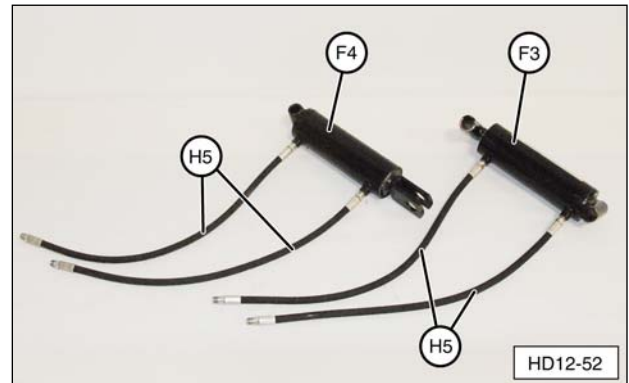

(F3) Forward Tilt Cylinder. (F4) Side Tilt Cylinder.
(H5) Hydraulic Hose Assembly.

4. Install forward tilt cylinder (F3) on base plate (F2), along with safety lever (F9, F10), as shown. Attach with long cylinder mounting pin (F7) and channel mounting pin (D6).

NOTE: Secure long cylinder mounting pin (F7) and channel mounting pin (D6) with Lynch pins (D7) (included).

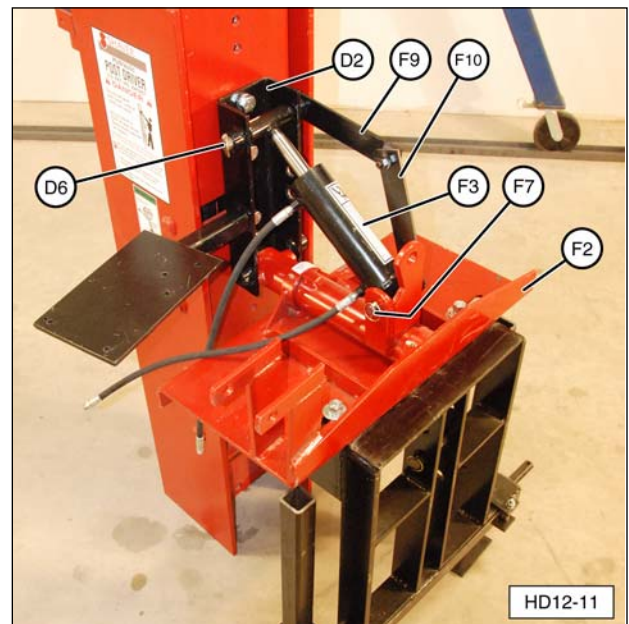

(D2) Short Channel Bracket. (D6) Channel Mounting Pin.
(F2) Base Plate. (F3) Forward Tilt Cylinder.
(F7) Long Cylinder Mounting Pin. (F9, F10) Safety Lever.

5. Install side tilt cylinder (F4) on base plate (F2), as shown. Attach with long cylinder mounting pin (F7) and short cylinder mounting pin (F8).

NOTE: Secure long cylinder mounting pin (F7) and short cylinder mounting pin (F8) with Lynch pins (D7) (included).

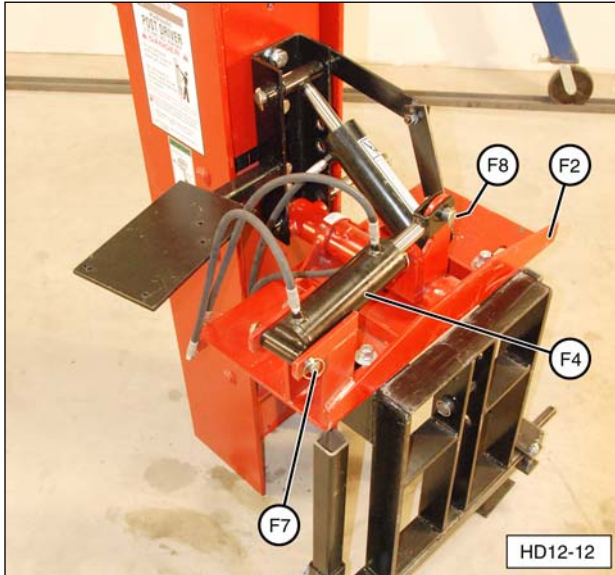

(F2) Base Plate. (F4) Side Tilt Cylinder. (F7) Long Cylinder Mounting Pin. (F8) Short Cylinder Mounting Pin.

6. Attach base plate (F2) to short channel bracket (D2).
 - a. With the main carriage channel still attached to an overhead lifting device, use a suitable floor jack to support three-point hitch weldment (K1).

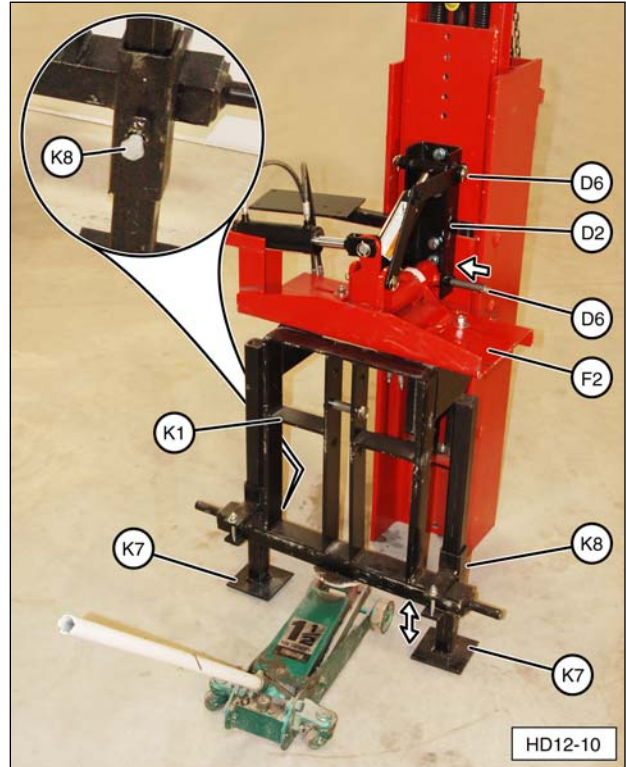

(D2) Short Channel Bracket. (D6) Mounting Pin.
 (F2) Base Plate. (K1) Three-Point Hitch Weldment.
 (K7) Stabilizer Leg. (K8) Stabilizer Leg Lock Bolt.

- b. Loosen stabilizer leg lock bolts (K8), and adjust floor jack up or down to align base plate (F2) pivot pin hole with short channel bracket (D2) lower mounting hole.
- c. Install lower channel mounting pin (D6) and secure with Lynch pins. Tighten two stabilizer leg lock bolts (K8) and remove the floor jack.

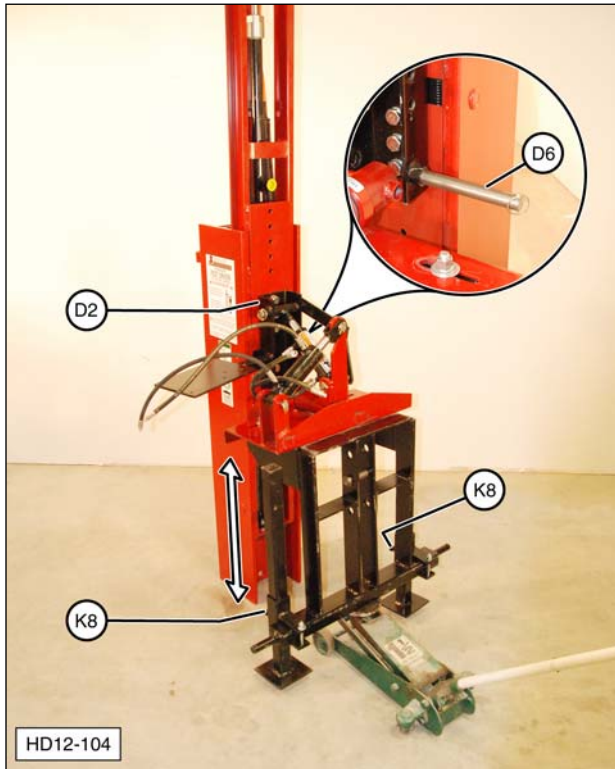

(D2) Hydraulic Short Channel Bracket.
 (D6) Mounting Pin. (K8) Stabilizer Leg Lock Bolts.

Hydraulic Valve

IMPORTANT NOTICE

Hydraulic system fittings that require a thread sealant, must be installed with a paste-type sealer only. Do not use a tape-type sealer such as Teflon Tape, as this can contaminate the system and voids the valve warranty.

1. Assemble the hydraulic control valve.
 - a. Remove the plastic plugs from hydraulic control valve (H1). Apply paste-type thread sealant (T12) to pipe threads. Install hydraulic fittings (G16, G18, G19, G21), and four tilt cylinder hose fittings (H3). Refer to the photographs for correct fitting placement and orientation.

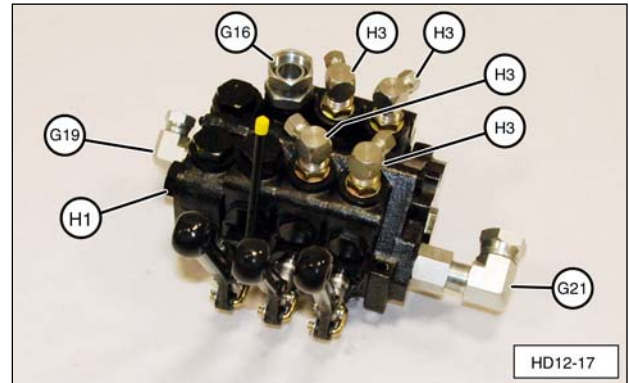

(H1) Hydraulic Control Valve.

(G16) Swivel Fitting:
 3/4" O-Ring Male to 1" Female NPT.

(G19) 90° Swivel Fitting:
 1-1/16" O-Ring Male to 1/2" Female.

(G21) 90° Swivel Fitting:
 3/4" Male to 1" NPT Female with
 Adapter Fitting:
 1-1/16" O-Ring Male to 3/4" NPT Female.

(H3) 90° O-Ring Swivel Fitting (with restricter):
 7/8" Male to 1/4" Female.

- b. Assemble the control valve linkage. Install levers (G5), control valve safety lever (G7), return spring (G10), and lever linkage (G11, G12, G23), as shown. Secure with cotter pins (G13). Refer to photographs for correct linkage placement and orientation.

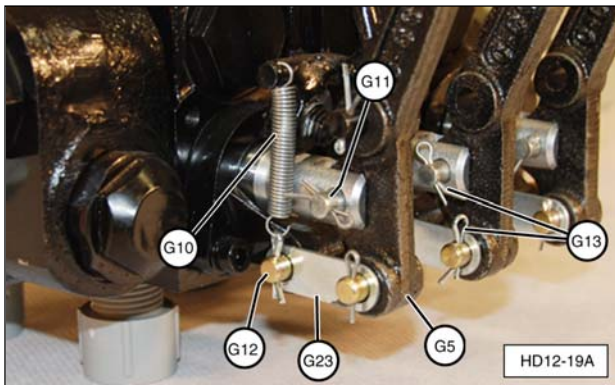
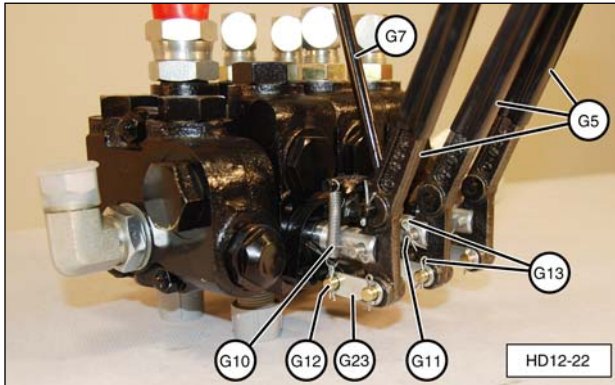

(H1) Hydraulic Control Valve Linkage.

(G5) Control Valve Levers. (G7) Control Valve Safety Lever. (G10) Safety Lever Return Spring. (G11) Clevis Pin. (G12) U-Link. (G13) Cotter Pin(s). (G23) Flat Link.

2. Install hydraulic valve (H1) on short channel bracket (D2) using three 5/16-18 x 3" valve mounting bolts (G2), washers (G3), and nuts (G4). Do not over-tighten the hardware, which can warp the valve body.

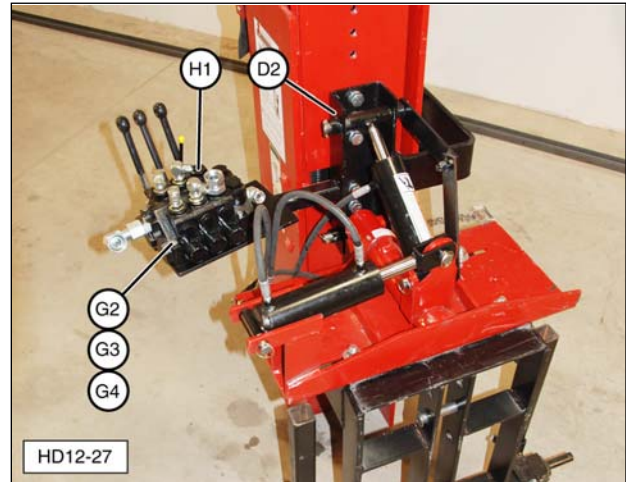

(D2) Short Channel Bracket. (G2) 5/16-18 x 3" Bolt. (G3) 5/16" Washer. (G4) 5/16-18 Nut. (H1) Hydraulic Control Valve.

IMPORTANT NOTICE

The hydraulic valve and cylinder(s) can be damaged by contamination (dirt and debris) from the oil in the tractor or power source. Ensure the oil is clean and properly filtered before connecting the Post Driver to a hydraulic power source. Failure to follow oil cleanliness standards voids the Shaver Post Driver warranty.

3. Attach the three main hydraulic hoses.

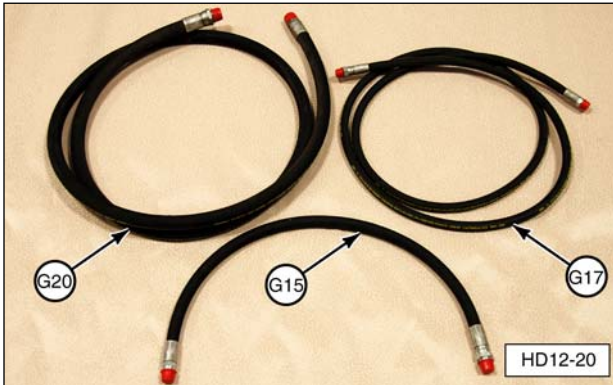

(G15) Valve to Drive Ram Hose. (G17) Pressure Supply Hose. (G20) Return Hose.

- a. Apply paste-type thread sealant (T12) to the pipe thread hose fittings and install drive cylinder hose (G15) (1" I.D. x 35") between hydraulic control valve (H1) and drive cylinder assembly (C1). Tighten the hose fittings securely.

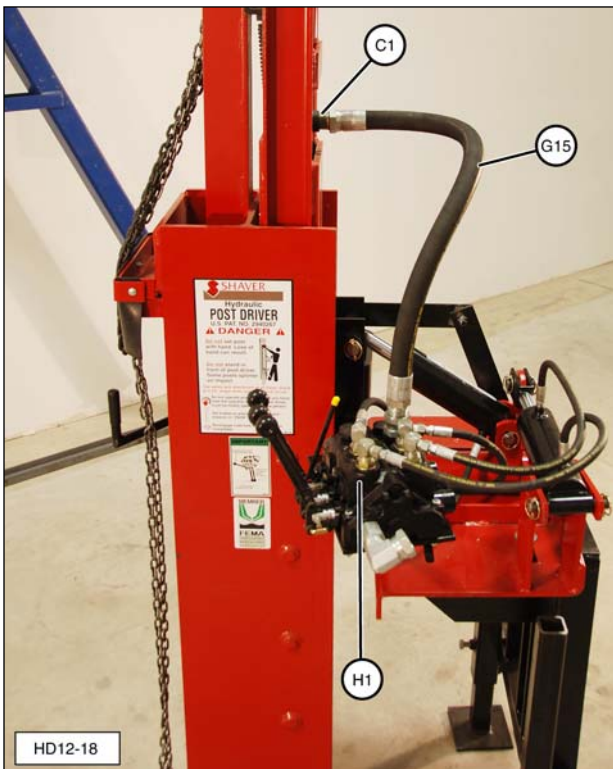

(C1) Drive Cylinder Assembly. (G15) Valve to Drive Ram Hose. (H1) Hydraulic Control Valve.

- b. Connect the threaded fitting on pressure hose (G17) (1/2" x 120") to hydraulic control valve (H1) swivel fitting.
- c. Connect the threaded fitting on return hose (G20) (1" x 120") to hydraulic control valve (H1) swivel fitting.

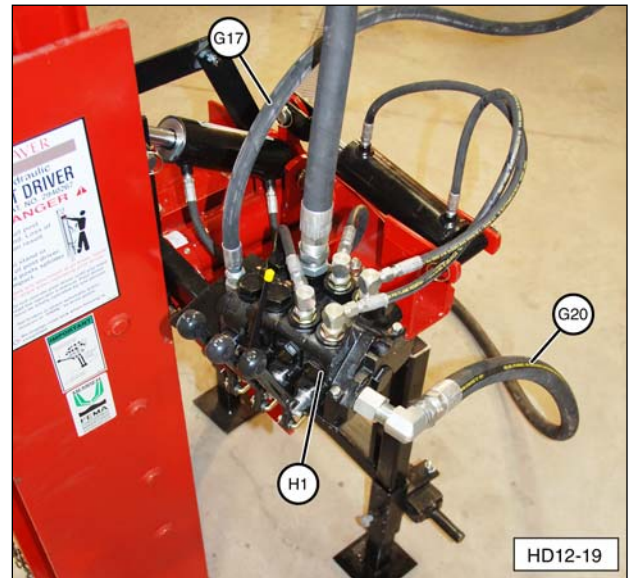

(G17) Pressure Hose. (G20) Return Hose. (H1) Hydraulic Control Valve.

NOTE: The owner/operator must supply suitable hydraulic quick disconnect fittings for connecting pressure supply hose (G17) and return hose (G20) to the tractor or power supply hydraulic system.

IMPORTANT NOTICE

If the tilt cylinder hoses are attached differently than shown, the control of the drive ram will not be as described in this manual.

- d. Attach two forward tilt cylinder hoses (H5) between forward tilt cylinder (F3) and hydraulic control valve (H1), as shown.

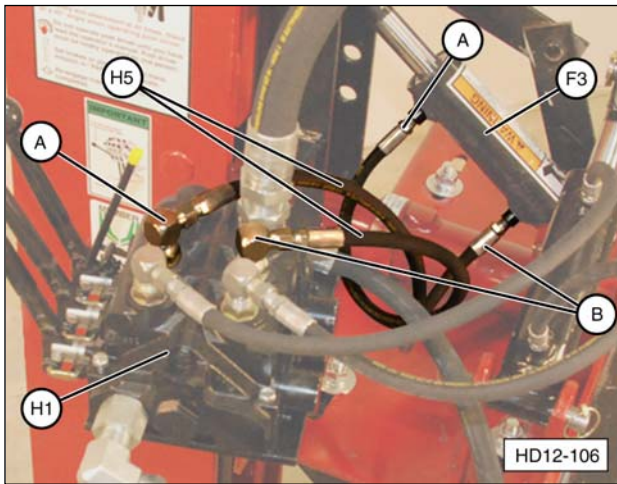

(A) Back Tilt Hose Connections. (B) Forward Tilt Hose Connections. (F3) Forward Tilt Cylinder. (H1) Hydraulic Control Valve. (H5) Tilt Cylinder Hoses.

- e. Attach two side tilt cylinder hoses (H5) between side tilt cylinder (F4) and hydraulic control valve (H1), as shown.

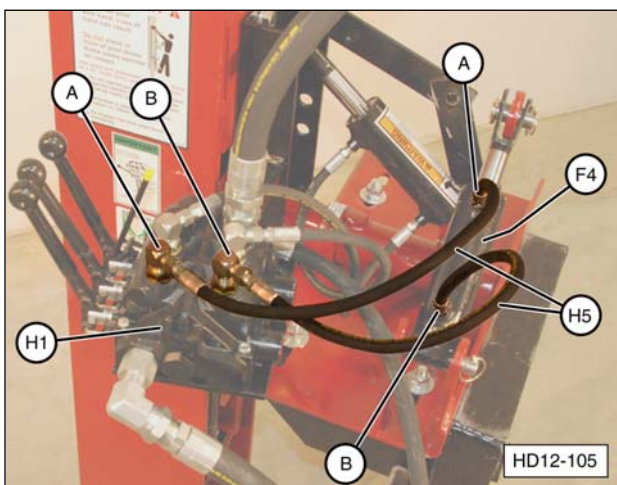

(A) Right Tilt Hose Connections. (B) Left Tilt Hose Connections. (F4) Side Tilt Cylinder. (H1) Hydraulic Control Valve. (H5) Tilt Cylinder Hose.

Safety Stop Adjustment

⚠ WARNING



To avoid serious injury, inspect the control valve safety stop before using the Post Driver the first time and before each daily use. Adjust the safety stop as needed, per the following procedure. Make sure all control valve hardware is tight. Always replace worn or damaged parts before use.

The control valve safety stop prevents unintentional activation of the Post Driver control valve and must be functional at all times.

NOTE: If the Post Driver is operational, before adjusting the safety stop, make sure the machine/power source is OFF, parking brake is set, road lock pin is installed, and all hydraulic pressure is released (zero pressure).

1. Attempt to push main hydraulic control valve lever (G5) forward (away from operator) **without** squeezing (pulling) yellow tipped control valve safety lever (G7).

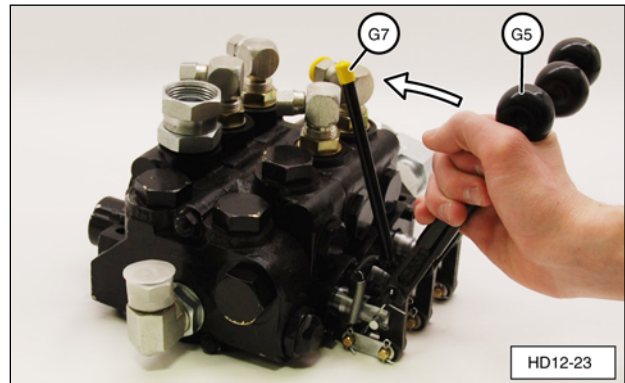

(G5) Main Hydraulic Control Valve Lever. (G7) Control Valve Safety Lever.

2. If main hydraulic control valve lever (G5) **CAN** move forward more than 1/4", the safety stop must be adjusted.

3. To adjust the safety stop, do the following:
 - a. Squeeze the control valve lever and the control valve safety lever together to expose the safety lever stop setscrew.
 - b. Insert a 1/8" Allen wrench and adjust the setscrew outward (counterclockwise) slightly. Remove the Allen wrench and repeat Step 1.

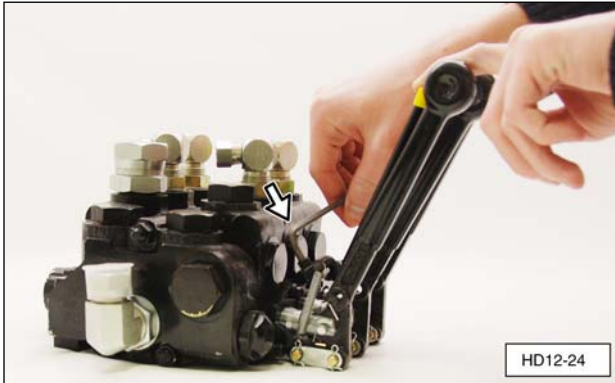

Adjust the Safety Stop Setscrew.

- c. If necessary, repeat Step 3a and Step 3b until the setscrew prevents more than 1/4" of forward movement of the control valve lever.

NOTE: Do not "over adjust" the setscrew. Make sure the setscrew easily falls into place behind the lip on the control valve when it is released quickly (1/8" gap at the setscrew).

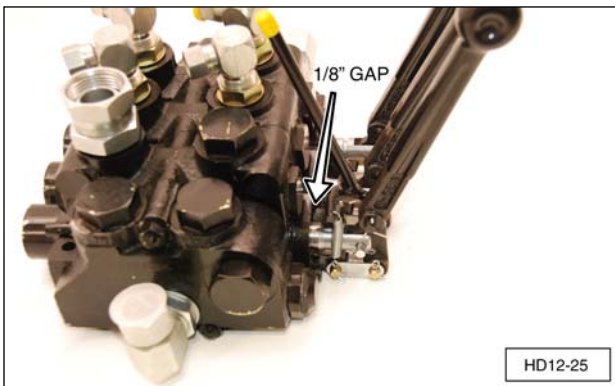

1/8" Gap Between Setscrew and Valve Body.

Rubber Debris Guard

1. Locate rubber debris guard (A4), guard mounting strap bracket (A5), and bag containing hardware and caution tag (A6, A7, A8, and A9).

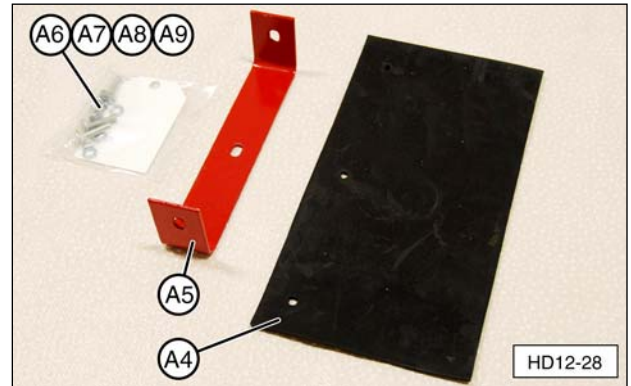

(A4) Rubber Debris Guard. (A5) Guard Mounting Strap Bracket. (A6) Caution Tag. (A7) Bolt. (A8) Lock Washer. (A9) Nut.

2. Attach the rubber debris guard, mounting strap, and caution tag on drive ram (A1) with guard mounting bolts, lock washers and nuts, as shown.

NOTE: To avoid damage to the rubber debris guard, do not over-tighten the mounting hardware.



(A1) Drive Ram.

Safety Arm

! WARNING



The safety arm is spring loaded. To avoid serious injury or death, the safety arm must be installed after the Post Driver has been mounted on a machine, or the freestanding Post Driver has been secured to prevent tipping.

1. Locate the safety arm assembly parts and hardware.

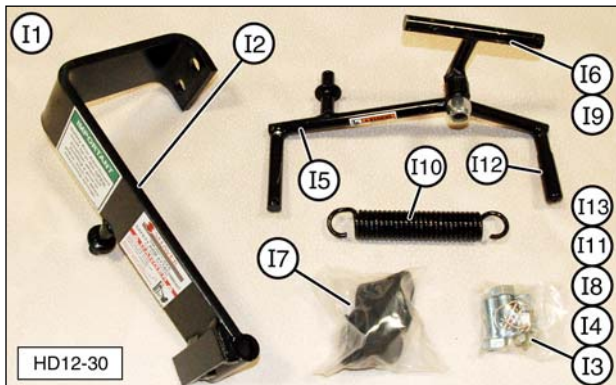

(I2) Safety Arm Frame. (I3) Frame Mounting Bolt.
 (I4) Self Locking Nut. (I5) Swing Arm Handle.
 (I6) Roller Bracket. (I7) Rollers. (I8) Roller Retainer Roll Pin.
 (I9) Roller Bracket Nut. (I10) Latch Spring.
 (I11) Spring Retainer Flat Washer. (I12) Swing Arm Handle Cover. (I13) Lynch Pin.

2. Attach safety arm frame (I2) to outside of short channel bracket (D2) with two 3/4-10 x 2" frame mounting bolts (I3) and self locking nuts (I4), as shown. Tighten the nuts securely.

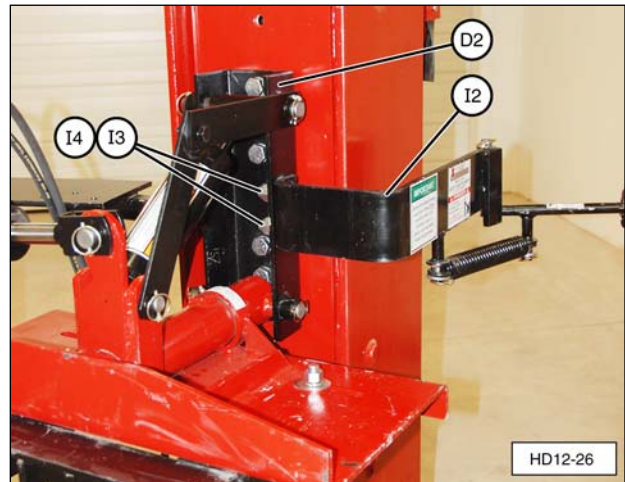

(D2) Hydraulic Short Channel Bracket.
 (I2) Safety Arm Frame. (I3) Frame Mounting Bolt.
 (I4) Self Locking Nut.

3. Assemble rollers (I7) onto roller bracket (I6) and use hammer (T1) to install two roller retainer roll pins (I8), as shown.

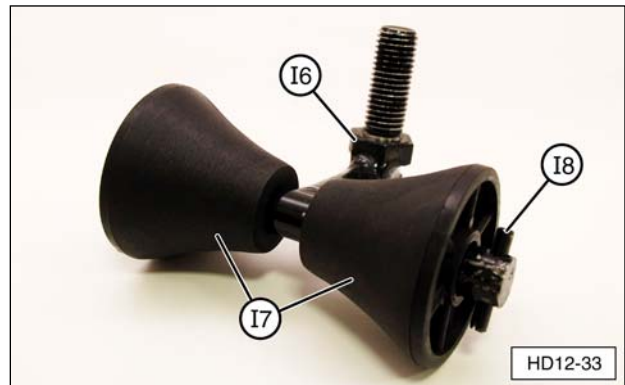

(I6) Roller Bracket. (I7) Roller.
 (I8) Roller Retainer Roll Pin.

4. Apply a light film of a good quality grease to the pivot shaft and attach roller bracket (I6) to swing arm handle (I5) with roller bracket nut (I9). Tighten the nut until seated and then loosen 1/4 to 1/2 turn.

NOTE: Roller bracket (I6) must swivel freely on swing arm handle (I5).

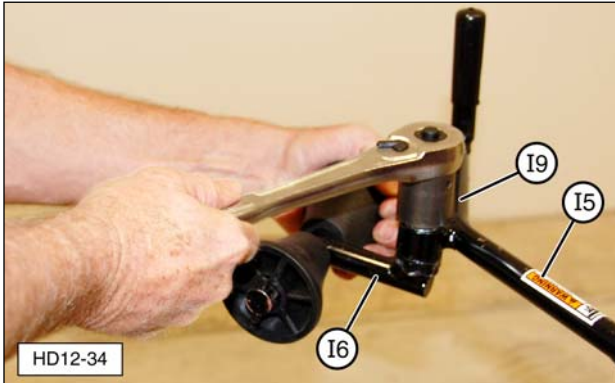

(I5) Swing Arm Handle. (I6) Roller Bracket.
(I9) Roller Bracket Nut.

5. Attach one end of latch spring (I10) to swing arm handle (I5), as shown. Secure with spring retainer flat washer (I11) and Lynch pin (I13).

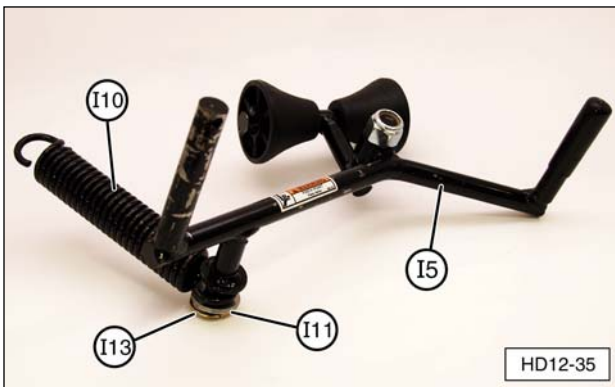

(I5) Swing Arm Handle. (I10) Latch Spring.
(I11) Spring Retainer Flat Washer. (I13) Lynch Pin.

6. Install the swing arm assembly.
 - a. Apply a light film of a good quality grease to the pivot shaft on swing arm handle (I5).
 - b. Start the pivot shaft into the main bracket tube, as shown. Slide the open spring eye over the main bracket anchor rod.



NOTE: Swing arm handle (I5) will be below safety arm frame (I2) bracket stop at this point.

- c. Secure the spring with flat washer (I11) and Lynch pin (I13).

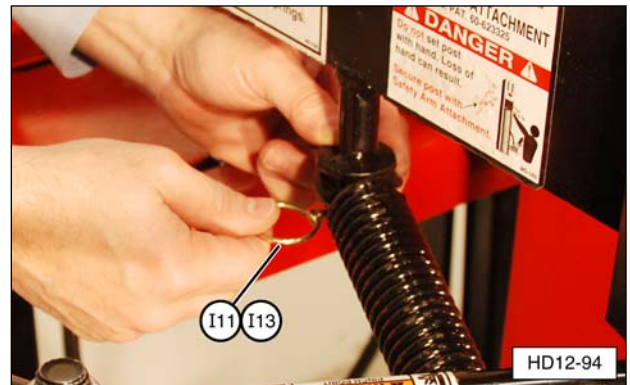

(I11) Flat Washer. (I13) Lynch Pin.

! WARNING



The safety arm is spring loaded. To avoid serious injury or death, the safety arm must be installed after the Post Driver has been mounted on a machine, or the freestanding Post Driver has been secured to prevent tipping.

7. Pull the swing arm handle around toward the Post Driver I-beam until the swing arm clears (swings past) safety arm frame (I2) bracket stop.

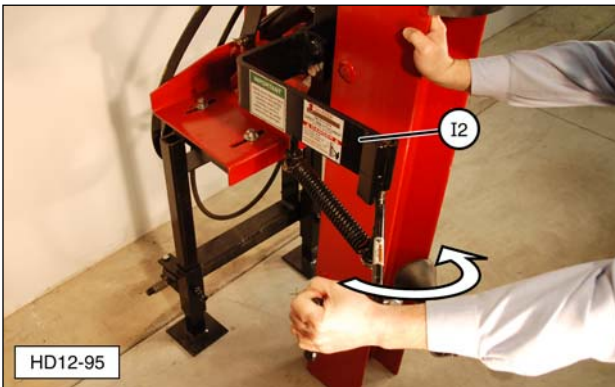

(I2) Safety Arm Frame.

8. Tap the swing arm shaft up through the safety arm frame tube.

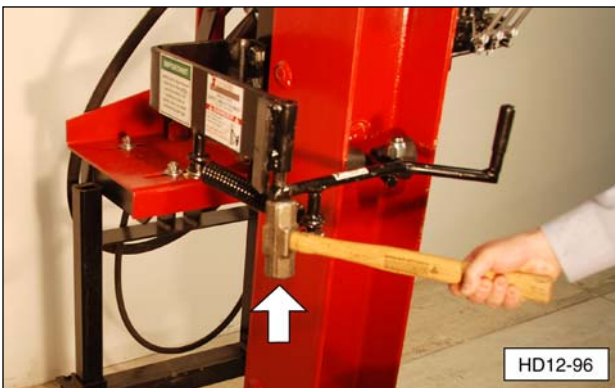

9. Install Lynch pin (I13) to secure the swing arm to the safety arm frame.



(I13) Lynch Pin.

10. Verify the swing arm handle opens against safety arm frame (I2) stop bracket and closes against back wall of drive ram (A1) I-beam.

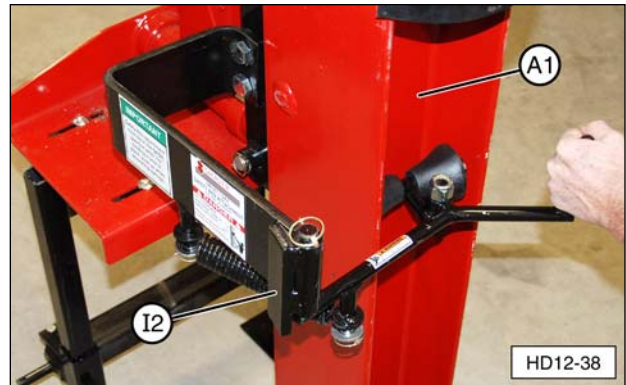

(A1) Drive Ram. (I2) Safety Arm Frame.

NOTE: When driving a fence post, the swing arm rollers must contact and hold the fence post in position, as shown.



Document Storage Tube



1. If desired, locate the document storage tube in a convenient location on the Post Driver. The photo below shows the tube mounted on the drive ram yoke, but other locations are acceptable.



2. Mark the location of the two mounting holes using the storage tube as a guide.
3. Drill two 3/16" holes.
4. Attach the storage tube with the two pop rivets (supplied inside the tube).

Post Driver Operation

Operational Safety Tips

1. Follow all safety information contained in this manual and refer to the safety decals located on the Post Driver.
2. Personal safety equipment must be worn at all times during operation, i.e. safety glasses, steel toe shoes, hearing protection, etc.
3. Always stand 45 degrees to the right of the post while the Post Driver is in operation.
4. **Do not** remove any of the Post Driver safety equipment or safety labels.
5. All Post Driver safety equipment must be inspected, maintained, kept in working order, and used during Post Driver operation.
6. **Do Not** place your hand(s) on top of the post when placing the post in the Post Driver or while the Post Driver is operating.
7. Leave the safety arm attachment open when not holding a post, except when transporting the Post Driver.
8. **Do not** remove the hydraulic control valve safety lever stop.
9. Never use the maximum force of the Post Driver until the post being driven is started into the ground and is straight.
10. Use caution when driving small diameter wood or steel posts. Maximum driving impact is not necessary.
11. Always be aware of the environment in which you are operating the Post Driver.
12. **Do not** operate the Post Driver on steep slopes, as this could cause a roll over.
13. Always check for underground utilities, i.e. wires, gas lines, waterlines, etc. Call your local utility companies for underground utility locations.
14. Use caution where large rocks or other objects could be hidden underground and not visible to the operator. The post could splinter and cause injury to the operator. If the post fails to drive into the ground after two or three strikes, move to another location.

15. **Do not** operate the Post Driver with the machine or power source unattended. The Post Driver requires two people for proper operation - one operating the Post Driver and one on the tractor.
16. Always engage the road lock pin in the drive ram lower hole before transporting the Post Driver. Engage the road lock pin in the drive ram upper hole for storage.

Operating Instructions

Mounting

1. With the Post Driver positioned on a hard level surface, move the tractor or other power supply toward the Post Driver until the three-point hitch lines up.
2. Attach the two lower, three-point hitch lift arms to Post Driver three-point hitch weldment (K1) hitch pins. Secure with lock pins (operator supplied).
3. Attach the three-point top link to removable pin (B8). Secure the upper pin with Lynch pin (B9).

NOTE: Adjust the length of the machine's top link, as required, to correctly attach the Post Driver.

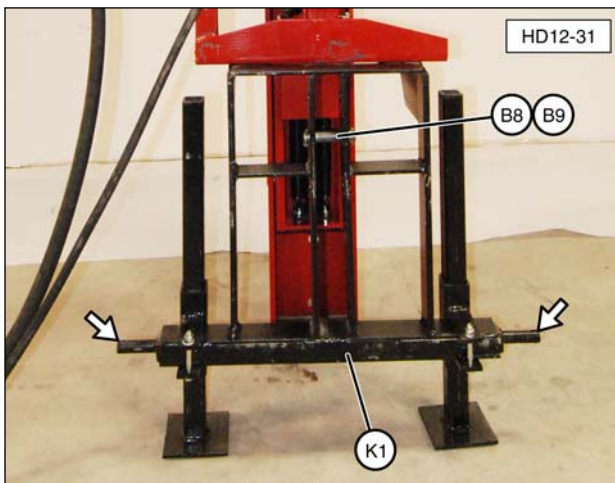

(B8) Top Link Pin. (B9) Lynch Pin.
(K1) Three-Point Hitch Weldment.

NOTE: The HD-12-H Post Driver will fit tractors with Category II or Category III three-point hitches. Use bushings (owner/operator supplied) on the hitch pins, if required, to correctly install the lift arms.

4. Attach hydraulic pressure supply hose (small diameter, G17) to the tractor pressure supply port. Attach hydraulic return hose (larger diameter, G20) to the tractor return port.

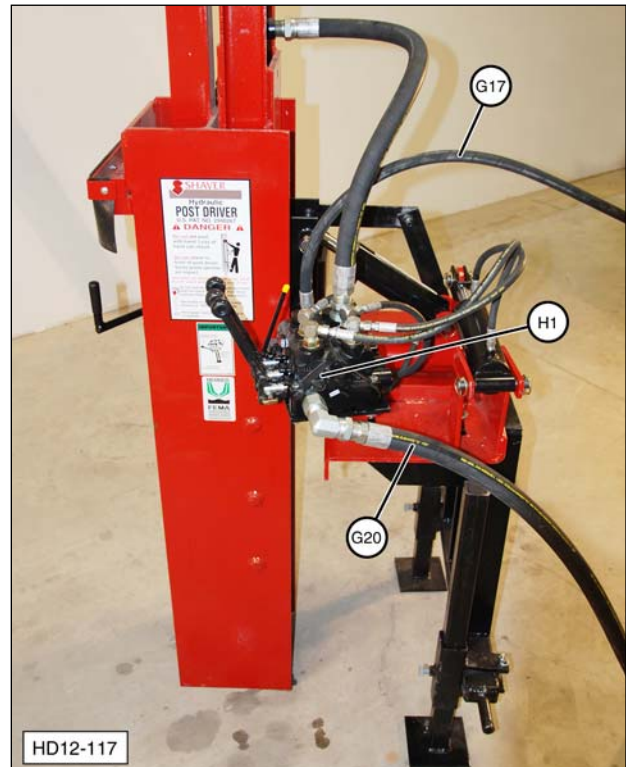

(H1) Hydraulic Control Valve. (G17) Hydraulic Pressure Supply Hose. (G20) Hydraulic Return Hose.

NOTE: The owner/operator is responsible for installing quick-disconnect fittings (or other suitable fittings) on the Post Driver hoses. Make sure the fittings are compatible with the tractor hydraulic fittings.

5. Make sure the safety arm frame is closed against the drive ram before transporting the Post Driver.

- If traveling more than 100 feet to the work site, remove road lock pin (B8). Raise drive ram (A1) and install the road lock pin in the lower "transport" position. The Post Driver can now be moved to the work site.

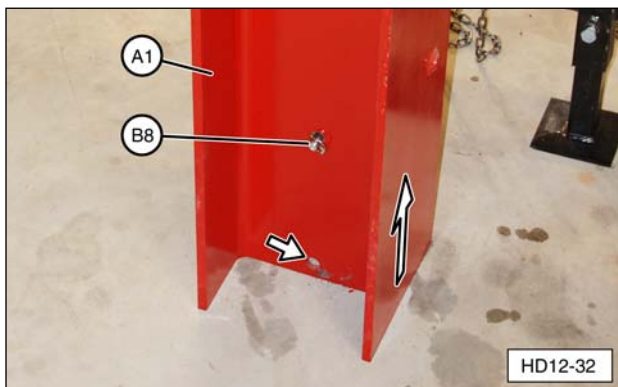

(A1) Drive Ram. (B8) Road Lock Pin (transport position).

Preparing to Drive a Post

- With the tractor three point hitch supporting the weight of the post driver, loosen stabilizer leg lock bolts (K8) and raise up each stabilizer leg (K7). Tighten the lock bolts to support the stabilizer legs.

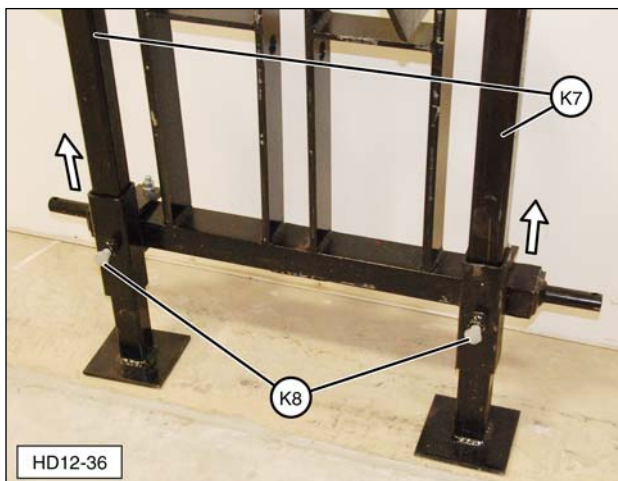

(K7) Stabilizer Leg. (K8) Lock Bolts.

- Position the tractor or power source in place to drive the first fence post.
- Set the brakes on the tractor or power supply. If the machine is equipped with an automatic transmission, the transmission must be in PARK.

- Remove road lock pin (B8) and lower drive ram (A1) until it rests on the road lock pin bracket rubber bumpers (not visible) inside main carriage channel (B1).

NOTE: Store the road lock pin in a secure location during Post driver operation.

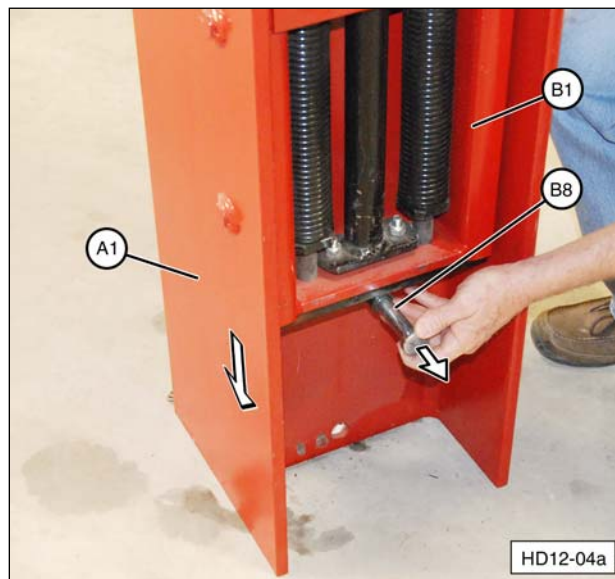

(A1) Drive Ram. (B1) Main Carriage Channel.
(B8) Road Lock Pin.

- Use the tractor three point hitch to lower the Post Driver until drive ram (A1) firmly contacts the ground.
- Continue to lower Post Driver main carriage channel (B1) an additional 1" (2.5 cm). This important step helps protect the lower rubber bumpers (B3) from premature wear and/or damage.

IMPORTANT NOTICE

If operating on uneven ground, make sure the stabilizer legs firmly contact the ground at each new fence post location. If necessary, loosen the stabilizer leg lock bolts to readjust the stabilizer legs, as needed. Failure to do so can cause damage to the Post Driver components.

- Loosen two stabilizer leg lock bolts (K8) and lower the stabilizer legs until both feet firmly contact the ground. Tighten the stabilizer leg lock bolts.

Driving a Post

! WARNING



To avoid personal injury or death, do not operate the Post Driver by yourself. Always have another person to control the machine or power source.

1. Lubricate eight guide blocks (A2) with clean oil before each daily use and, if necessary, between post installations.

NOTE: For clarity, in this photograph the lubrication points are shown on the partially assembled post driver.

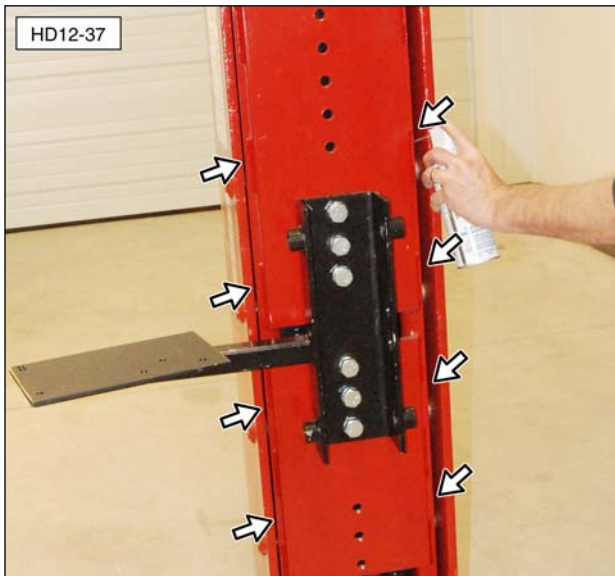

IMPORTANT NOTICE

Do not use grease on the guide blocks or in the main carriage channel. Grease will retain abrasive material, which will result in premature wear.

2. Have the tractor or power source operator raise and maintain the engine RPM to supply the hydraulic pressure and flow necessary to properly operate the Post Driver.

NOTE: The tractor or other power source must be capable of maintaining adequate hydraulic pressure (engine RPM) to smoothly operate (cycle) the Post driver.

3. To raise drive ram (A1), squeeze safety lever (G7) and pull back main hydraulic control valve lever (G5).

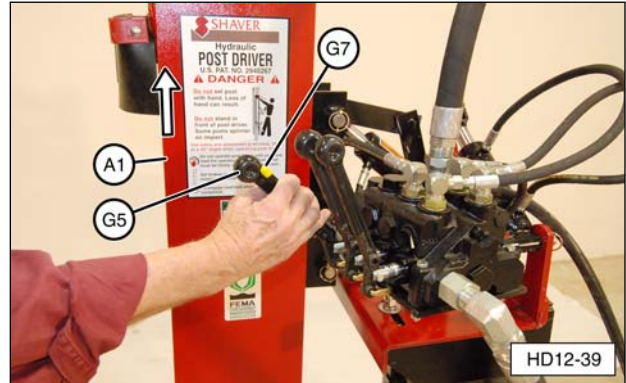

(A1) Drive Ram. (G5) Hydraulic Control Valve Lever. (G7) Safety Lever.

IMPORTANT NOTICE

At the beginning of each day, use the main hydraulic control lever to cycle the drive ram up and down 10 to 15 times, without impact with a post or the ground, to “season” the drive ram return springs. Failure to follow this recommendation can cause damage to the springs.

NOTE: The first time the Post Driver is used, it may be necessary to operate the hydraulic control valve levers a few times, to remove air from the hydraulic system.

- To drive the fence post straight, adjust the main carriage channel side-to-side and fore-and-aft tilt using the second and third hydraulic control valve levers.

IMPORTANT NOTICE

If the tilt cylinder hoses are attached differently than shown, the control of the drive ram will not be as described in this manual.

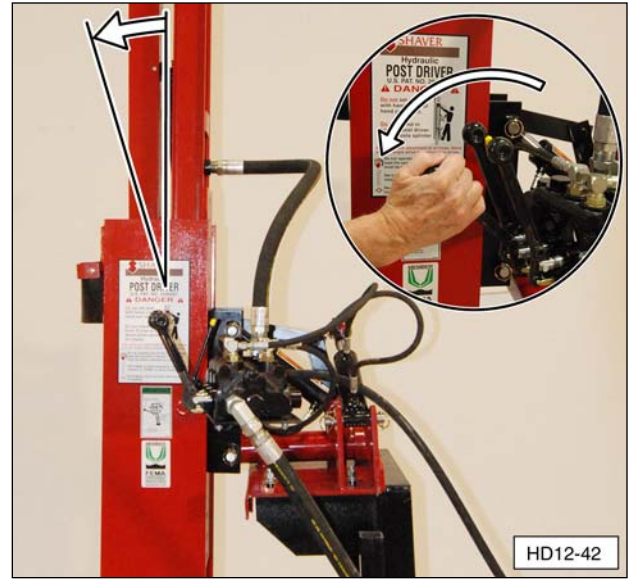

Tilt Top of Drive Ram Away From Tractor.

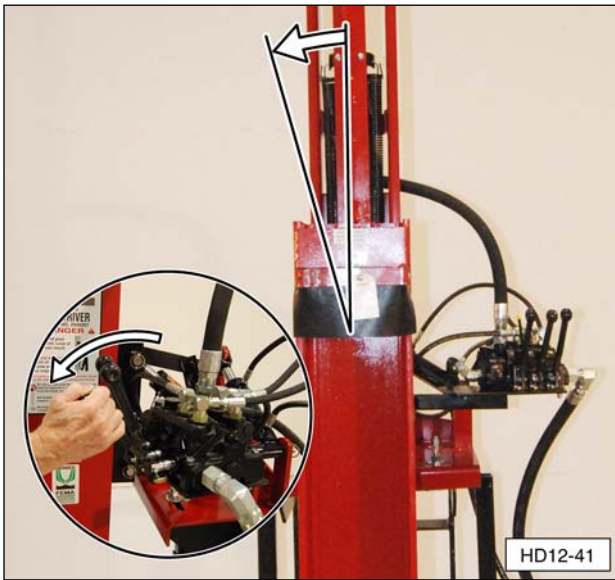

Tilt Top of Drive Ram Away From Operator.

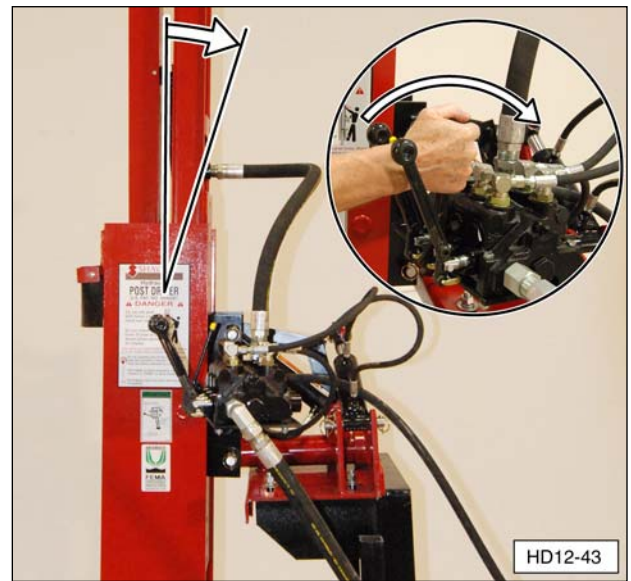

Tilt Top of Drive Ram Toward Tractor.

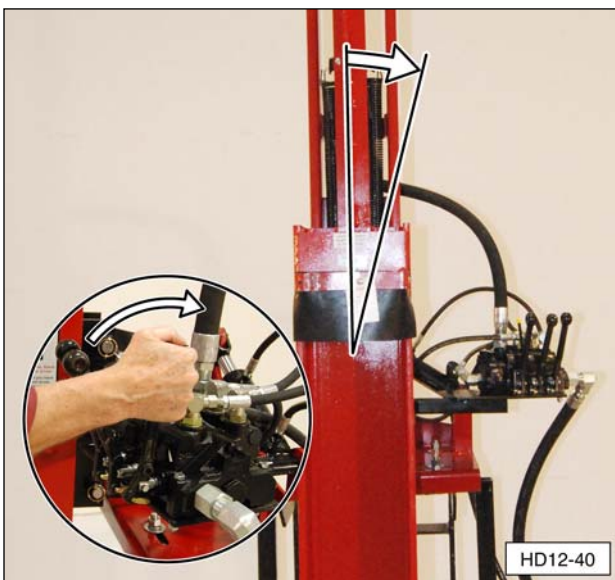

Tilt Top of Drive Ram Toward Operator.

! WARNING



Potential pinch points. Keep hands clear of Post Driver while operating. Never place hand(s) on top of a post when inserting it into the Post Driver. Always close the safety arm before driving the post.

5. With drive ram (A1) in the raised position, open safety arm frame (I2) and place a fence post in the drive ram I-beam, under the drive ram plate. There should be a 1" to 2" gap between the top of the fence post and the bottom of the drive ram plate.

NOTE: For clarity, the photo below shows the rubber debris guard raised up. Never drive a fence post without the guard in place over the drive ram plate.



6. Close safety arm frame (I2) to secure the post (the adjustable roller assembly keeps tension on the post while it is being driven).

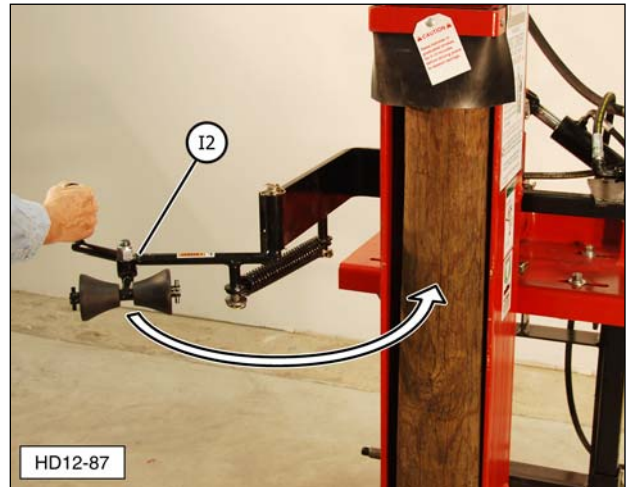

(I2) Safety Arm Frame.

7. **Do not** stand in front of the drive ram while operating the Post Driver. Stand at a 45 degree angle to the side of the Post Driver, in front of the hydraulic control valve.



IMPORTANT NOTICE

Posts will drive into the ground much straighter using shorter strokes. Use caution when driving small diameter wood and steel posts. Maximum impact is not necessary with these smaller diameter posts and can cause damage (splintering or breakage) of posts.

8. Squeeze control valve safety lever (G7) and push control valve lever (G5) forward to release the drive ram and create impact.

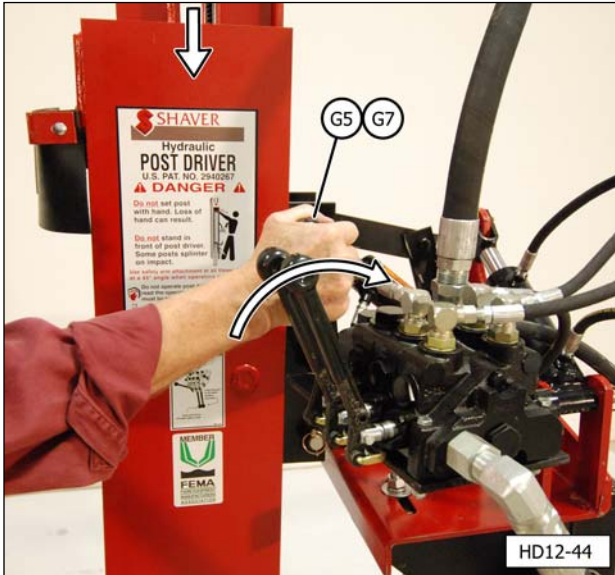

(G5) Control Valve Lever. (G7) Control Valve Safety Lever.

9. Pull back the control valve safety lever and handle to raise the drive ram again. Continue this process, as needed, to drive the post to the desired depth.

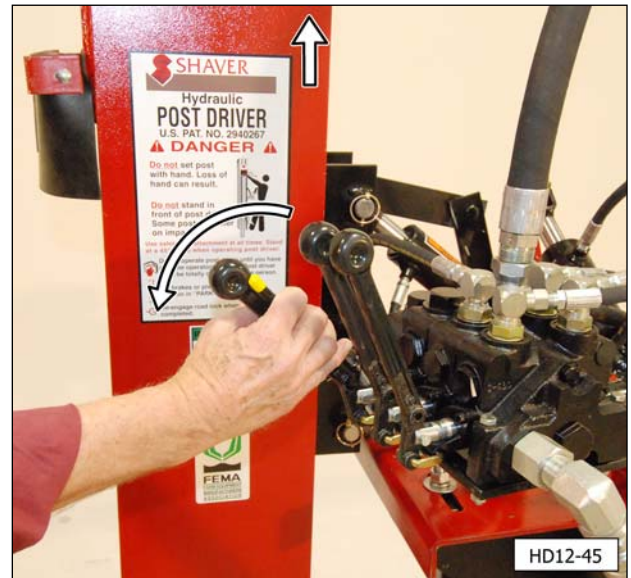

NOTE: If the post stops moving down or is crooked after a few impacts, stop and move the post to a different location. Conditions such as thick sod, rocks, or tree roots can cause splintered or broken posts.

10. Once a post is driven to the desired depth or the bottom of the drive ram contacts the ground, release the hydraulic control lever.
11. Open safety arm frame (I2).
12. Use the three point hitch to raise the Post Driver and move to the next location to begin driving a new post.
13. If traveling more than 100 feet, close the safety arm frame and install the road lock pin in the lower "transport" position. The Post Driver can now be moved to the next work site position or the storage location.

Dismounting Post Driver

1. Install road lock pin (B8) in the upper "storage" position.
2. The Post Driver should be stored on a hard level surface. Lower the drive ram until it is on the ground.

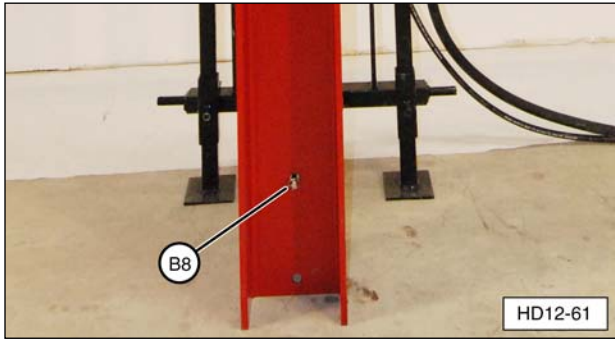

3. Adjust (raise or lower) the stabilizer legs to allow the drive ram I-beam to make full contact with the ground. Make sure the Post Driver is stable.

! WARNING



Securely tighten the bolt/nut on the cylinder stop bracket when storing the post driver. Failure to tighten the stop bracket could cause an unstable condition, resulting in serious injury or death.

4. Completely tighten bolt (F11) and nut (F13) on the cylinder stop bracket to prevent the tilt cylinder from drifting, causing an unstable condition with the Post Driver.

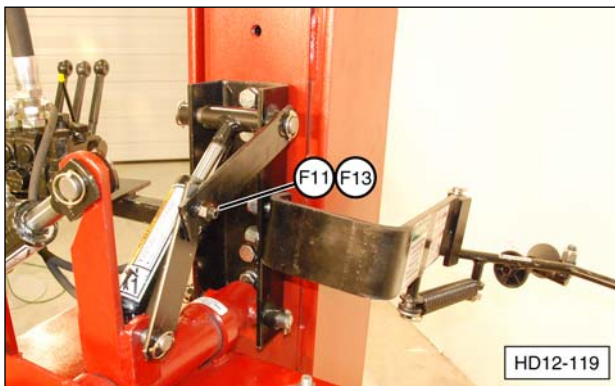

(F11) Cylinder Stop Bolt. (F13) Cylinder Stop Nut.

NOTE: On units without stabilizer legs, store the unit next to a post driven into the ground. Position the unit with the driving ram against the post and secure with a chain wrapped securely around the post and Post Driver.

5. Make sure all pressure is released (zero pressure) from the Post Driver hydraulic system. Disconnect hydraulic pressure supply hose (G17) from the tractor. Disconnect hydraulic return hose (G20) from the tractor.

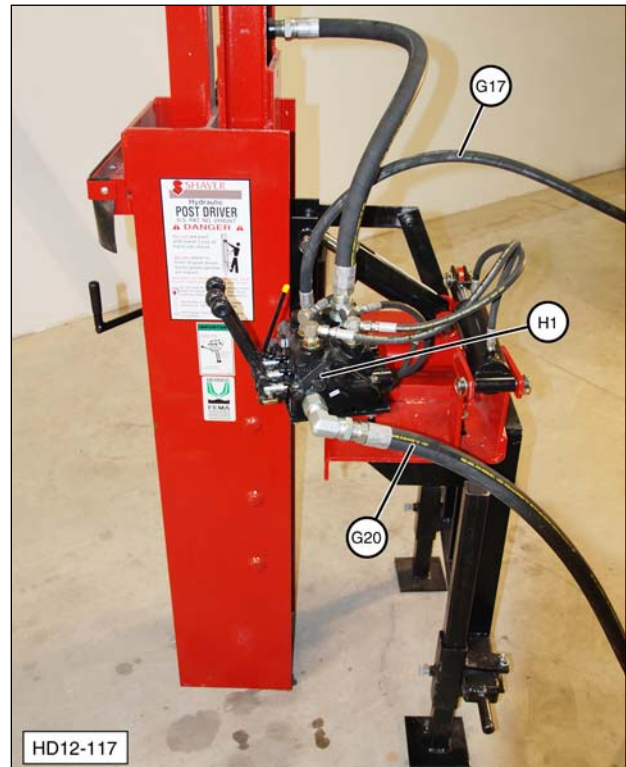

(G17) Hydraulic Pressure Supply Hose. (G20) Hydraulic Return Hose. (H1) Hydraulic Control Valve.

6. Remove top link pin (B8) from three point hitch weldment (K1) to disconnect the three-point hitch top link. Disconnect the two lower lift arms from the three-point hitch weldment to separate the tractor three-point hitch from the Post Driver.
7. Carefully move the tractor or power source away from the Post Driver.

Troubleshooting

NOTE: Refer to the Service Parts section of this manual for a photo and description of all the parts.

Problem: Drive ram (A1) will not move or slide freely on main carriage channel (B1).

Possible Cause/Solution(s):

1. Guide blocks (A2) lack lubricant. Lubricate with clean engine oil.
2. Guide blocks (A2) are installed incorrectly. Refer to Service Information section assembly procedures for correct orientation.
3. Incorrect clearance between main carriage channel (B1) and drive ram (A1) I-beam. Refer to Service Information section for clearance specifications.
4. Hydraulic drive cylinder assembly (C1) is not parallel to main carriage channel (B1). Refer to Service Information section, hydraulic drive cylinder installation, and parallelism adjustment.
5. Main carriage channel (B1) or drive ram (A1) is bent or damaged. Discontinue use and order replacement parts.

Problem: Poor performance, low or no impact, hydraulic drive cylinder will not extend.

Possible Cause/Solution(s):

1. Weak or broken drive ram springs (C14).
2. Broken upper spring bracket (A11).
3. Bent or damaged hydraulic drive cylinder assembly (C1).
4. Main carriage channel (B1) is binding.
5. Restricted or plugged hydraulic hose(s) (G15, G17, G20).
6. Low or no hydraulic pressure or flow from the machine or power source.

Problem: Rubber bumpers (B3) have premature or excessive damage.

Possible Cause/Solution(s):

1. Post Driver is not properly adjusted prior to operation and drive ram guide blocks (A2) are contacting rubber bumpers (B3).

Storage

For the best results, always store equipment in a dry, protected location. Leaving equipment unprotected will shorten the service life of the Post Driver.

1. Before storing, remove debris and clean the entire unit using compressed air or a pressure washer.
2. Inspect the Shaver Post Driver. Replace any worn or damaged parts before using the Post Driver again.
 - Check all bolted connections. Ensure that fasteners are tight, and all pins are secured in place.
 - Inspect the frame for structural fractures.
 - Make sure all warning decals are in place and legible.
 - Make sure the rubber debris guard is in place and in good condition.
 - Check the hydraulic cylinder(s) for signs of seal damage or excessive wear.
 - Inspect all hydraulic hoses and fittings for leaks or signs of wear.
3. After cleaning, lightly lubricate the guide blocks with clean engine oil. Do not apply grease, as this will retain grit and cause excessive wear.
4. Clean and lubricate the hydraulic control valve safety stop linkage. Make sure the return spring and cotter pins are in good condition.
5. Apply a light coating of clean grease to all exposed hydraulic cylinder shafts to help prevent rust.

Service Procedures

WARNING



To avoid personal injury or death, carefully read and understand all instructions before attempting to assemble and/or operate the Post Driver. Do not operate or work on equipment unless you read and understand the instructions and warnings in this and all other applicable manuals. Contact Shaver Manufacturing Company if any of the instructions provided are unclear or not understood. Proper care is your responsibility. Always follow all State and Federal health and safety laws and/or local regulations.



To help prevent personal injury, protective equipment must be worn during Post Driver assembly, operation, and maintenance. Personal protective equipment should include, but not be limited to, safety glasses, hearing protection, protective gloves, and steel toe footwear.



Personal injury can result from slips or falls. **DO NOT** leave tools or parts laying around the work area, and clean up all spilled fluids immediately.



Due to the size and weight of the Post Driver, two people are required for the disassembly and assembly procedures.

NOTE: Disassembly, assembly, and/or associated repairs must be performed with the main carriage channel and drive ram in a horizontal position, such as on a suitable pallet, or heavy-duty support stands.

Refer to Dismounting Post Driver from Machine/Power Source section for steps to remove Post Driver from a tractor or other power source.

Three-Point Hitch/Post Driver Disassembly

1. Secure the Post Driver upright [main carriage channel (B1) and drive ram (A1) assembly] to an appropriate overhead lifting device to prevent tipping.
2. Disconnect drive cylinder to valve hose (G15) and drain fluid into a suitable container.
3. Completely tighten cylinder stop arm bolt/nut (F11, F13). Disconnect four tilt cylinder hoses (H5) from hydraulic control valve (H1), and drain the fluid into a suitable container.
4. Remove Lynch pins (D7) and two channel mounting pins (D6) that connect the base plate to the Post Driver upright.
5. With assistance, carefully move the three-point hitch weldment/base plate assembly away from the Post Driver upright. Store the weldment/base plate assembly in a safe location.
6. The upright assembly is heavy. Use an appropriate lifting device to position the Post Driver assembly horizontally, on suitable stands, pallet, or blocks on the ground.

NOTE: Be prepared to collect any hydraulic fluid that drains from the cylinder into a suitable container.



Main Carriage Channel Disassembly

1. Remove road lock pin (B8). Slide the main carriage channel up as far as possible to relieve the extra tension on the springs.

NOTE: If necessary, use retaining strap (T19), as shown, to pull main carriage channel (B1) and release tension on road lock pin (B8) allowing easy removal.

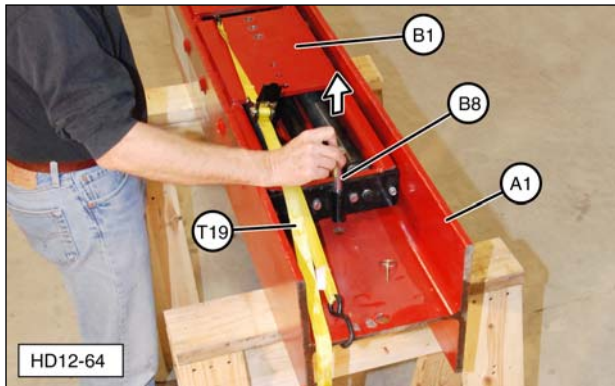

(A1) Drive Ram. (B1) Main Carriage Channel.
(B8) Road Lock Pin. (T19) Retaining Strap.

2. Remove the retaining strap and slide main carriage channel (B1) up. Loosen, but **do not remove** two lower bolts (B11) that attach each return spring (C14) to the main carriage channel.

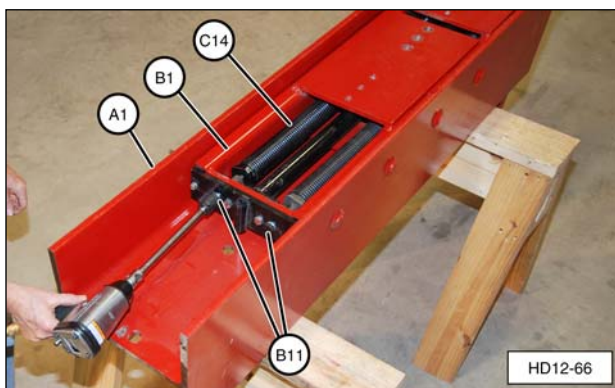

(A1) Drive Ram. (B1) Main Carriage Channel.
(C14) Return Spring.

3. To release tension on the springs, loosen lower spring bolts (B11) only enough so that threads are still fully engaged in lower spring mount, as shown.

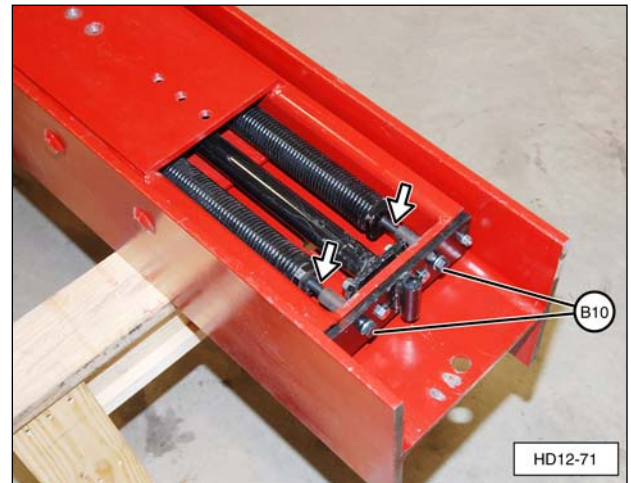

(B11) Lower Return Spring Bolts

4. Remove upper cylinder rod self-locking nut (C4) and lock washer (C16) from drive cylinder piston (C3).

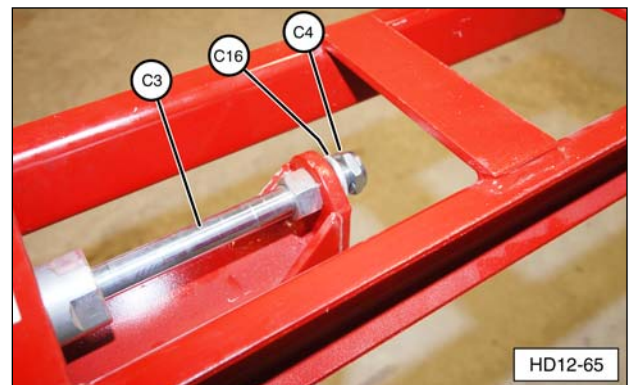

(C3) Drive Cylinder Piston. (C4) Self-Locking Nut.
(C16) Lock Washer.

! WARNING



Potential pinch points. The spring can suddenly retract (compress) when upper spring bracket bolt is removed. Keep hands clear of return springs during bolt removal.

5. Carefully loosen and remove two upper return spring retaining bolts (C16).

NOTE: There can be tension remaining on spring (C14). As the bolt is removed, the spring will quickly retract (compress) away from upper spring bracket (A11).

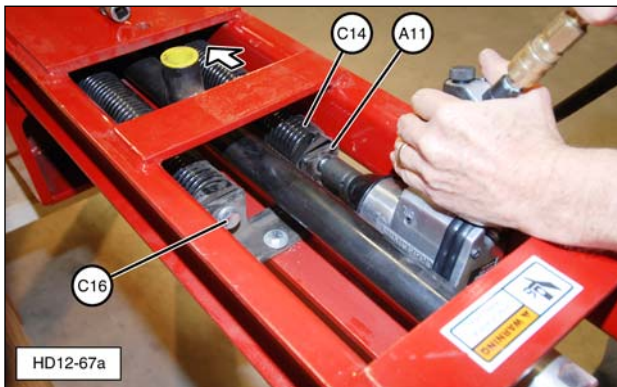

(A11) Upper Spring Bracket. (C14) Return Spring.
(C16) Upper Spring Bolt

6. Once the two upper spring mounting bolts are removed, completely remove two lower spring bracket bolts (B11), that were loosened in Step 2. Save all bolts, lock washers and sleeves for reuse.

7. Remove upper spring bracket bolts, washers, and nuts (C8) (not shown), lift up on drive cylinder (C1) and remove upper spring bracket (A11) from inside main carriage channel (B1).

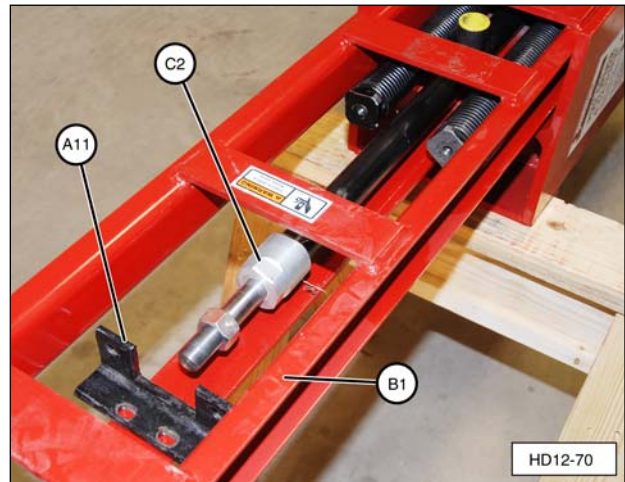

(A11) Upper Spring Bracket. (B1) Main Carriage Channel. (C2) Drive Cylinder.

8. Slide each return spring (C14) out from the top of drive ram (A1) and main carriage channel (B1), as shown.

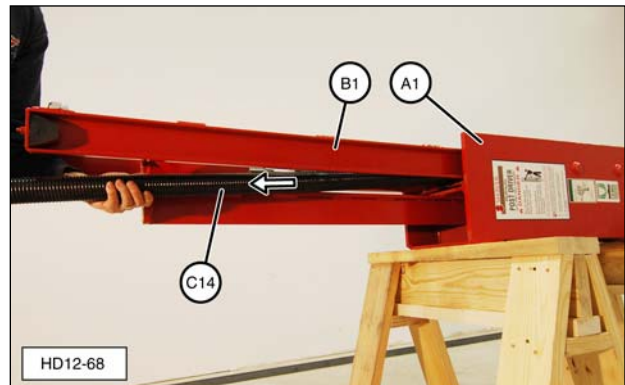

- Remove drive cylinder (C1) two lower lock nuts (C12) and two road lock bracket nuts (B7). Remove road lock bracket (B2).

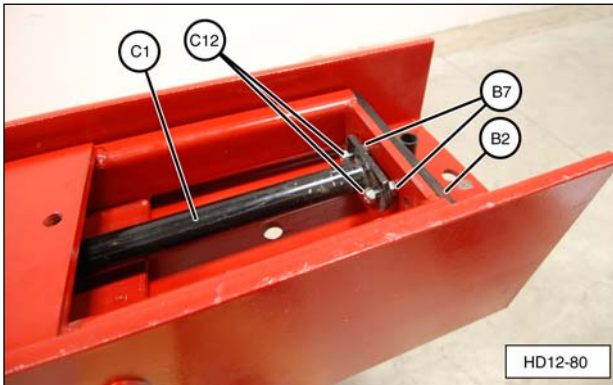

(B2) Road Lock Bracket. (B7) Road Lock Bracket Nuts. (C1) Drive Cylinder. (C12) Lock Nuts.

- Slide the main carriage channel down and remove drive cylinder (C1) by sliding it out the top of drive ram assembly (A1).

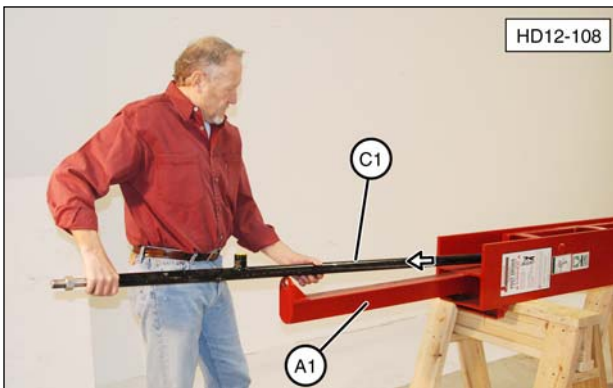

(A1) Drive Ram Assembly. (C1) Drive Cylinder.

NOTE: Refer to Drive Cylinder Seal Replacement section for cylinder service procedures.

- Use an overhead lifting device to support main carriage channel (B1). Remove the main carriage channel by sliding it out the top of drive ram (A1).

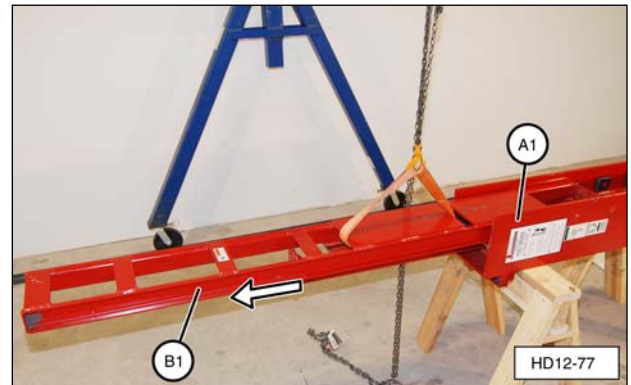

(A1) Drive Ram. (B1) Main Carriage Channel.

IMPORTANT NOTICE

Note the number and thickness of shims, and location of each shim pack removed. This information is needed for correct drive ram reassembly.

- Remove guide blocks (A2) and shims (A3) from the pins inside the drive ram I-beam.

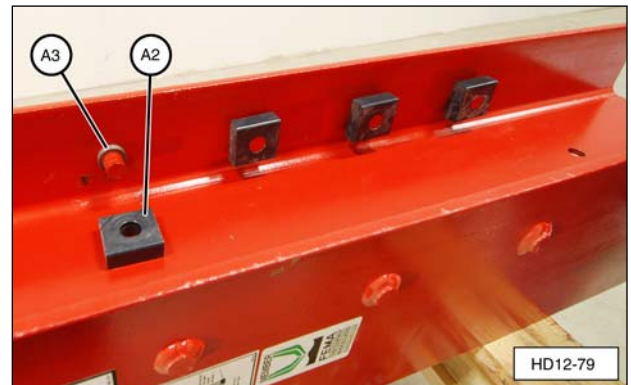

(A2) Guide Blocks. (A3) Shims (behind guide blocks).

- Inspect contact points on guide blocks (A2) for excessive wear and the replace guide blocks, as necessary.
- Inspect the drive ram, main carriage channel, springs, rubber bumpers, and all other components. Replace any worn or damaged parts before assembling the Post Driver.

Drive Cylinder Seal Replacement

1. Remove drive ram cylinder assembly (C1) from the Post Driver, as outlined in the disassembly instructions.

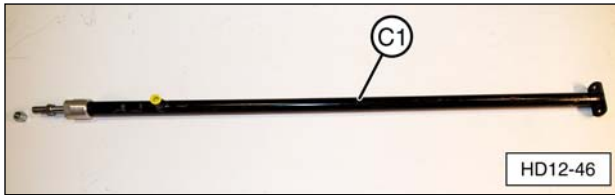

(C1) Drive Ram Cylinder Assembly.

2. Be prepared to collect any hydraulic fluid that drains from the cylinder into a suitable container. Unscrew cylinder cap (C7) and remove cylinder piston rod (C3) from the cylinder housing.

NOTE: Care must be taken during removal to prevent scoring of cylinder piston rod (C3) or the inside of cylinder tube (C2).

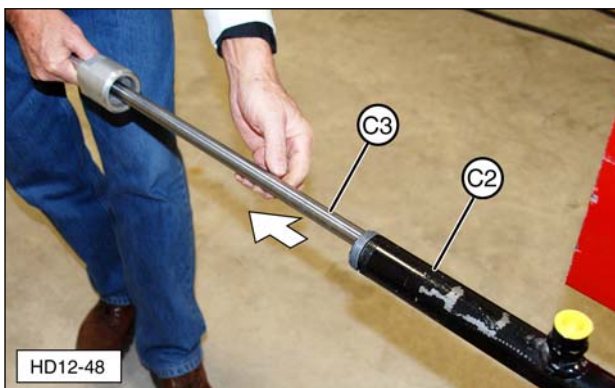
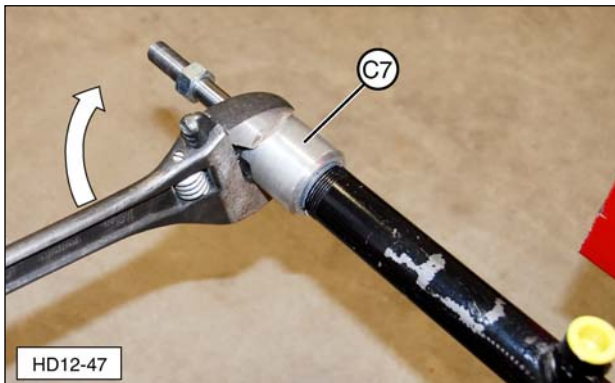

(C2) Cylinder Tube. (C3) Cylinder Piston Rod.
(C7) Cylinder Cap.

3. Inspect the threads on the outside of drive cylinder (C2) tube and inside of cylinder cap (C7). Repair or replace components with damaged threads.
4. Remove self-locking piston guide nut (C11) and piston rod guide (C10), using a 1-1/4" wrench to hold the piston rod guide while removing the piston guide nut. Discard the self-locking nut and replace with new.

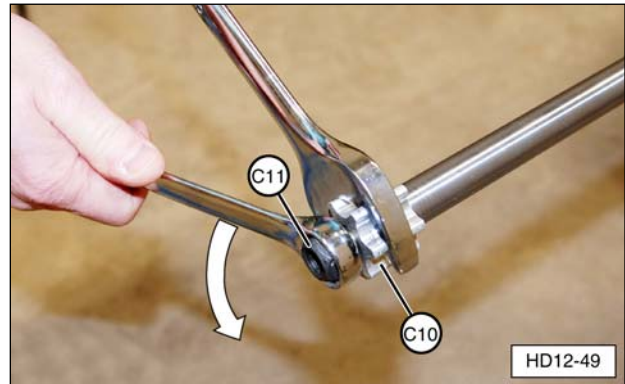

(C10) Piston Rod Guide. (C11) Self-Locking Piston Guide Nut.

5. Place cylinder cap (C7) and cylinder cap seal (C9) in hot (120°F) water for ten minutes. Soaking the cap and seal will make the seal more pliable and easier to remove.

! WARNING



The cylinder cap and seal will be hot. To avoid personal injury, wear protective gloves and take precautions to avoid direct contact with hot surfaces.

6. Wear gloves, and use a sturdy seal pick to remove cylinder cap seal (C9) from cylinder cap (C7).

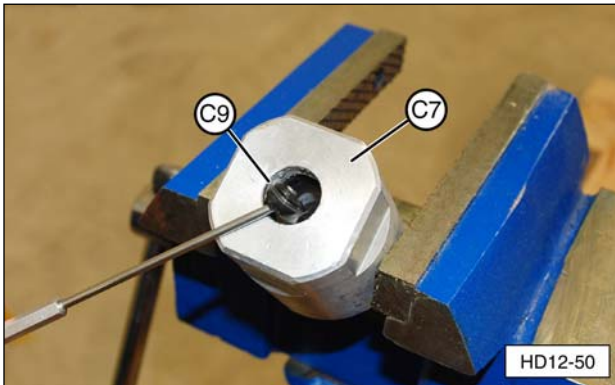

(C7) Cylinder Cap. (C9) Cylinder Cap Seal.

7. Clean the seal groove in the cylinder cap and place the new seal in hot (120°F) water for ten minutes.
8. Once the seal is pliable, squeeze the new seal together making a banana shape. Place one end of the seal into the cylinder cap seal groove. Continue to push the seal into the seal groove, holding the seal in the groove from the bottom with one finger, while continuing to push the seal down from the top until the seal snaps in place.

IMPORTANT NOTICE

Care must be taken not to damage the new seal while installing it. Do not use a sharp tool, such as a screwdriver, to push the seal into place. A suitable diameter impact socket with rounded edges can be useful in pushing the seal into the cap groove.

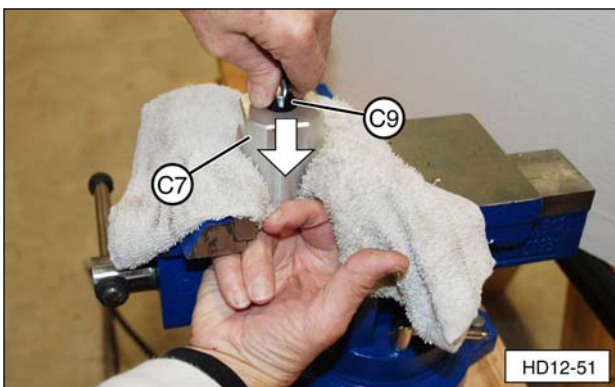

(C7) Cylinder Cap. (C9) Cylinder Cap Seal.

9. Once cylinder cap seal (C9) is in the groove, double check for correct orientation. The sharp edge of the seal must be down (towards the threads inside the cap).
10. Lubricate the seal with clean hydraulic fluid and slide the cap onto cylinder piston rod (C3) from the **bottom**.

IMPORTANT NOTICE

Do not slide the cylinder rod cap over the top of the drive cylinder rod. The threads will damage the new cylinder rod cap seal.

11. Install piston guide (C10) and new self-locking piston guide nut (C11), using a 1-1/4" wrench to hold the piston guide while installing the piston guide nut. Do not over-tighten the self-locking nut. Piston guide (C10) must be able to rotate on cylinder piston rod (C3).
12. Install cylinder piston rod (C3) assembly into drive cylinder tube (C2).

NOTE: Care must be taken during installation to prevent scoring of cylinder piston rod (C3) or the inside of drive ram cylinder tube (C2).

13. Apply paste-type thread sealant (T12) on drive cylinder tube (C2) external threads and install cylinder cap assembly (C7). Tighten the cap securely.

IMPORTANT NOTICE

Hydraulic system fittings that require a thread sealant must be installed with a paste-type sealer only. Do not use a tape-type sealer such as Teflon Tape, as this can contaminate the system and voids the valve warranty.

14. To install drive cylinder assembly (C1) in the Post Driver, follow the instructions in the Main Carriage Channel Assembly section.

Main Carriage Channel Assembly

1. Install guide block shims (A3) and guide blocks (A2) on the pins inside drive ram I-beam. Make sure the shims are installed in their original locations.

NOTE: The square (sharp edges) on guide blocks must be positioned horizontally to correctly fit the width of main carriage channel frame.

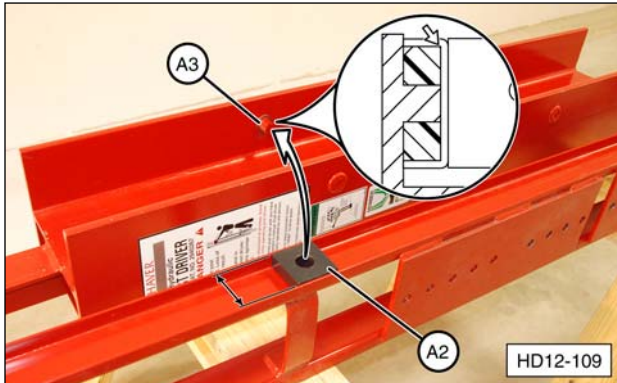

(A2) Guide Blocks. (A3) Guide Block Shims.

2. Lubricate the guide blocks with clean oil to reduce friction. Use an overhead lifting device to lift and support the main carriage channel (B1). Get assistance to slide the main carriage channel over the guide blocks, from the top of drive ram (A1).

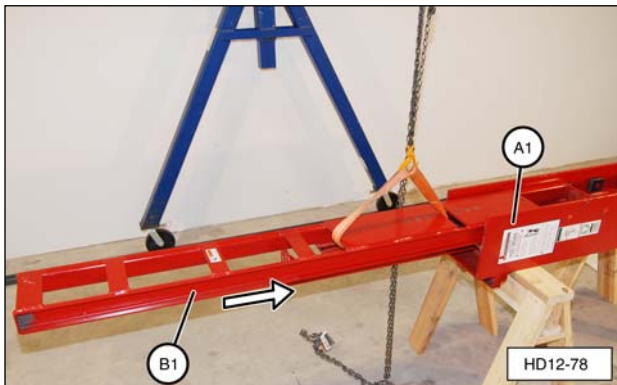

(A1) Drive Ram. (B1) Main Carriage Channel.

3. Make sure the main carriage channel will slide back and forth freely, without contacting or rubbing the drive ram.

4. With the drive ram assembly horizontal, check up and down movement of the main carriage channel in the drive ram I-beam. Up and down movement should not be less than 1/4" or more than 1/2".
5. Install drive cylinder (C1) in drive ram assembly (A1) from the top (upper end).

NOTE: Hydraulic drive ram cylinder (C1) must be installed in main carriage channel (B1) before springs (C14) are installed. Position the cylinder laying loose inside the main carriage channel.

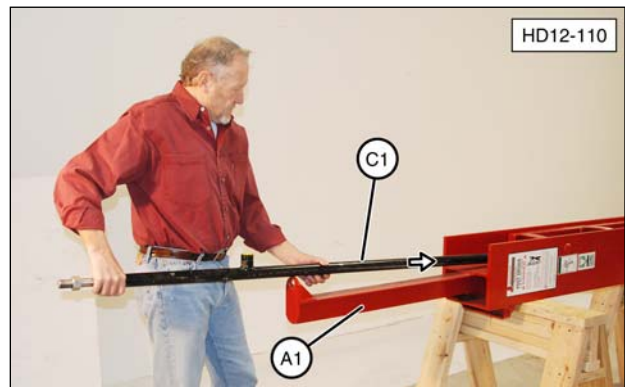

(A1) Drive Ram. (C1) Drive Cylinder.

7. If removed, install two rubber bumpers (B3) on road lock bracket (B2)

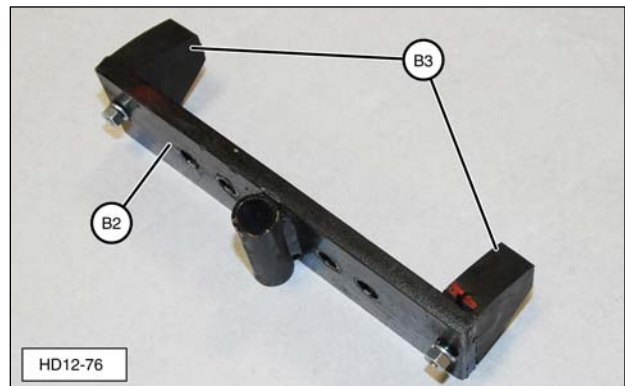

(B2) Road Lock Bracket. (B3) Rubber Bumper.

8. Install road lock bracket (B2) on the main carriage channel. Install road lock bracket bolts (B6) and road lock bracket nuts (B7). For easy drive cylinder alignment, leave the nuts slightly loose and install drive cylinder (C1) lower bracket over bolts, as shown.

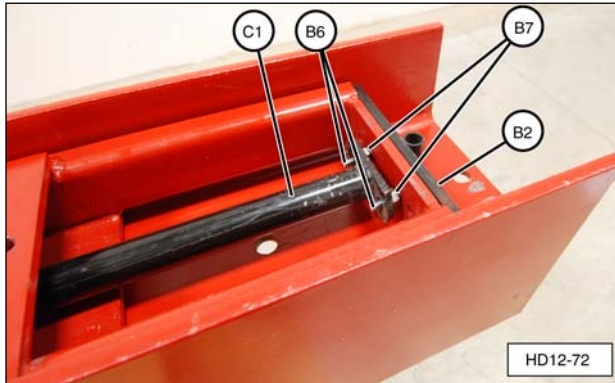

(B2) Road Lock Bracket. (B6) Road Lock bracket Bolts. (B7) Road Lock Bracket Nuts. (C1) Drive Cylinder.

9. Install but **do not tighten** lock nuts (C12) on road lock bracket bolts (B6). Once the lock nuts are started, completely tighten road bracket nuts (B7) on bolts (B6).

NOTE: To allow for drive cylinder alignment, self-locking nuts (C12) must still be loose at this point.

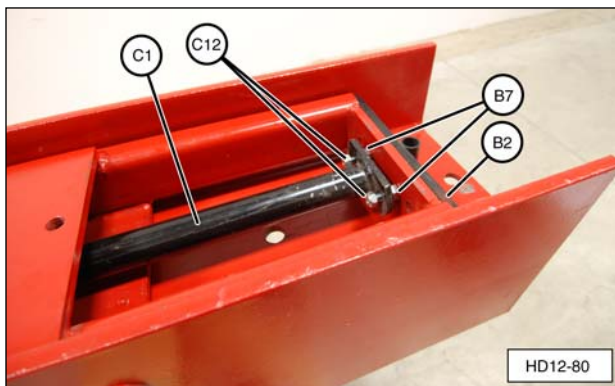

(C1) Drive Cylinder. (C12) Self-locking Nuts. (B7) Road Lock Bracket Nuts.

10. With main carriage channel (B1) slid up as far as possible, install each spring (C14) from the bottom of the Post Driver between drive ram (A1) I-beam and the main carriage channel. Slide each spring into position.

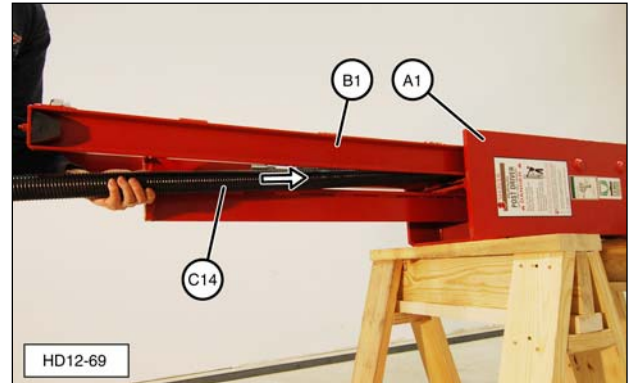

(A1) Drive Ram. (B1) Main Carriage Channel (C14) Return Spring.

11. Attach the springs to the lower and upper spring brackets.

- a. Install lower bolts (B10) lockwashers and sleeves as shown. Thread the bolts into lower spring mount just enough to fully engage the bolt threads.

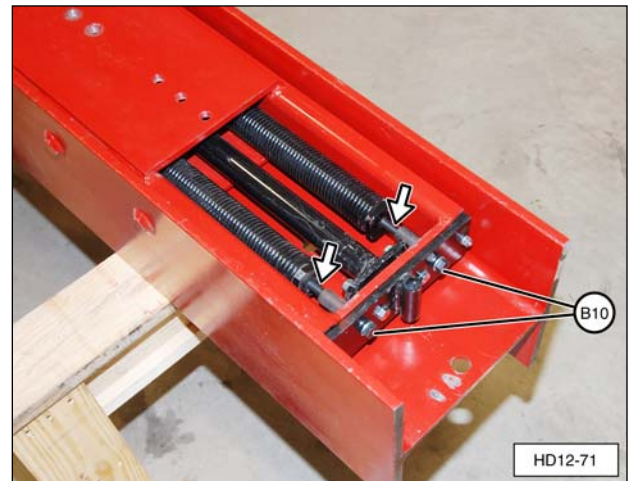

(B10) Lower Spring Bolts.

- b.** Position upper spring bracket (A11) inside the main carriage channel and slide it, under drive cylinder (C1), up to the upper spring mounts.

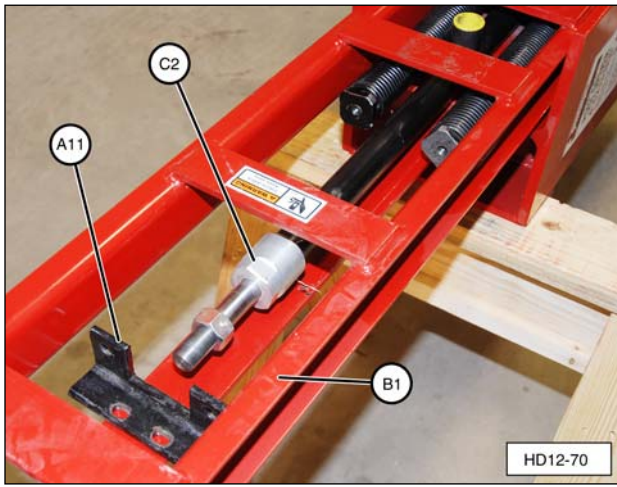

(A11) Upper Spring Bracket. (B1) Main Carriage Channel. (C2) Drive Cylinder.

- c.** Install upper spring bracket bolts and lockwashers (C16, C17) through upper spring bracket (A11). Do not tighten the bolts. Thread the bolts into return spring (C14) upper mounts just enough to fully engage the threads.

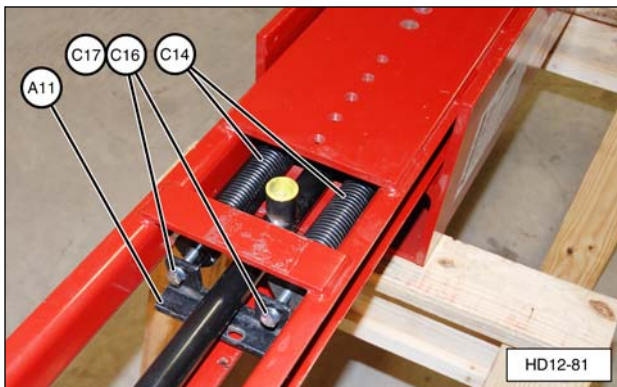

(A11) Upper Spring Bracket. (C14) Return Spring. (C16) Upper Spring Bolt. (C17) Lockwasher.

- 12.** Attach drive cylinder piston rod (C3) to the top of the drive ram I-beam using new lock washer (C16) and self-locking nut (C4). Install the nut by hand just enough to fully engage the threads.

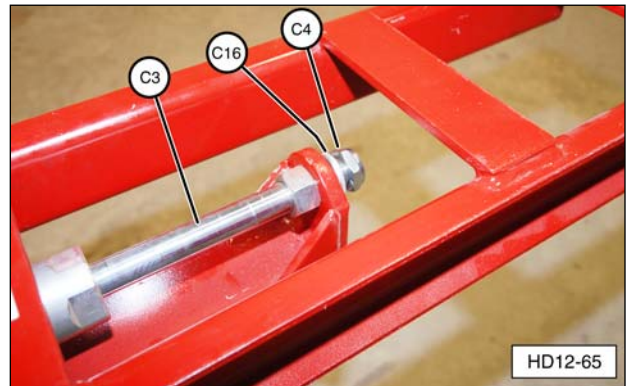

(C3) Drive Cylinder Piston Rod. (C4) Self-Locking Nut. (C16) Lock Washer.

- 13.** Attach the upper spring bracket to the drive ram yoke. The distance between the mounting holes in the upper spring bracket and drive ram yoke will be approximately two inches.

- a.** Get assistance and use a suitable round pry bar to engage one set of holes in both the bracket and drive ram yoke. Pry the bracket forward until the second set of holes are aligned.
- b.** While holding the bracket in this position, secure the bracket using hardware (C8) (bolt, washer, lockwasher, and nut) in the other hole, as shown.

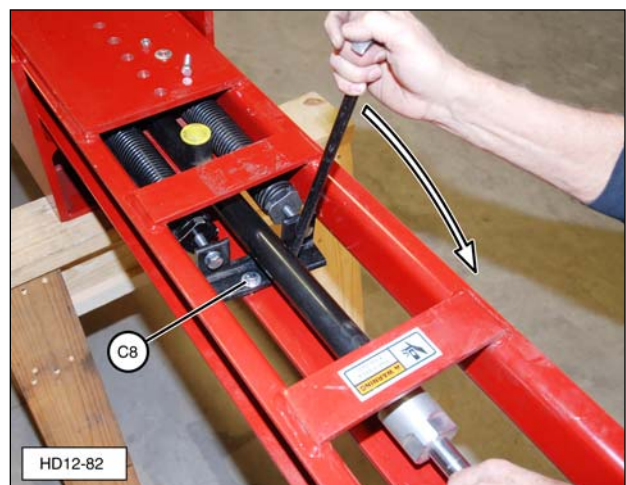

(C8) Upper Spring Bracket Hardware.

- c. Remove the pry bar and install remaining upper bracket hardware (C8) (bolt, washer, lockwasher, and nut). Tighten both the nuts securely.
- d. Completely tighten two upper spring mount bolts (C16).

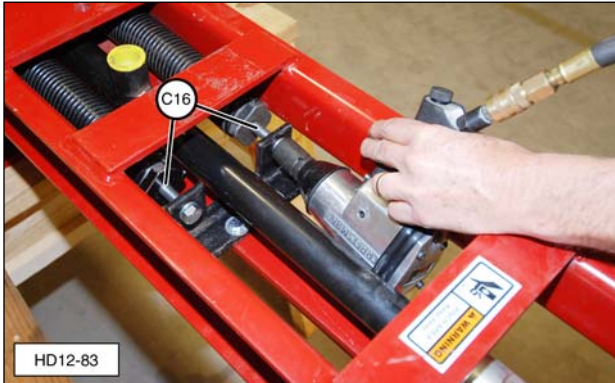

(C16) Upper Spring Mounting Bolts.

- e. Completely tighten lower spring mount bolts (B10) that were left loose in Step 11a.
- f. Tighten drive cylinder self-locking nuts (C12) that were left loose in Step 8. Tighten each nut slightly, in turn, to align the drive cylinder inside the main carriage channel.

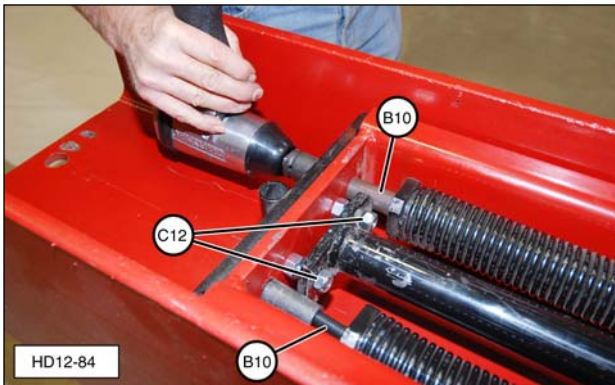

(B10) Lower Spring Mount Bolts. (C12) Self-locking Nuts.

- 14. Tighten the drive cylinder upper self-locking nut (C4) by holding the lower nut with a 1-1/8" wrench and tightening the self-locking nut using a 1-1/16" wrench. Then loosen the self-locking nut 1/2 turn (180 degrees).

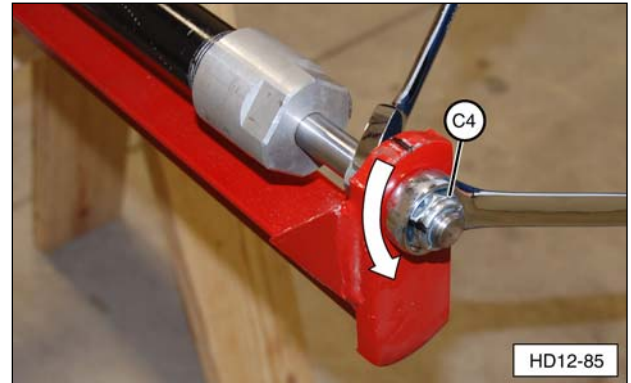

(C4) Self-locking Nut.

- 15. Pull main carriage channel (B1) down and install road lock pin (B8) and Lynch pin (B9) in lower hole in drive ram (A1).

NOTE: If necessary, use retaining strap (T19) to overcome the spring tension and pull the main carriage channel down, so road lock pin (B8) can be easily installed.

- 16. To avoid binding, the drive cylinder and rod must be parallel to the sides of the main carriage channel. If necessary, make the following adjustments:
 - a. Make sure the top drive ram cylinder self-locking nut is loosened 1/2 turn.
 - b. Loosen lower drive ram cylinder self-locking nuts (C12).
 - c. Tighten or loosen each nut slightly, in turn, to align the drive cylinder inside the main carriage channel.

NOTE: Self-locking nuts (C12) do not have to be completely tightened against the lower spring bracket.

Forward and Side Tilt Cylinder Maintenance

Cylinder Disassembly

WARNING



Removing tilt cylinder(s) from the assembled Post Driver can cause an unstable condition. To avoid personal injury or death, make sure the drive ram is fully supported by other means before removing the tilt cylinders for service.

1. When removing the cylinder(s) from the assembled Post Driver, make sure the drive ram is fully supported by other means, such as a suitable overhead lifting device.
2. Clean the outside of tilt cylinders (F3, F4).
3. Disconnect tilt cylinder hydraulic hoses (H5) from the hydraulic control valve. Plug the fittings to prevent dirt from entering the hydraulic system.

NOTE: Be prepared to collect any hydraulic fluid that drains from the cylinder and hoses, into a suitable container.

4. Remove tilt cylinders (F3, F4) from the base plate by removing the mounting pins.
5. Inspect the tilt cylinder mounting points. Replace any worn or damaged components.

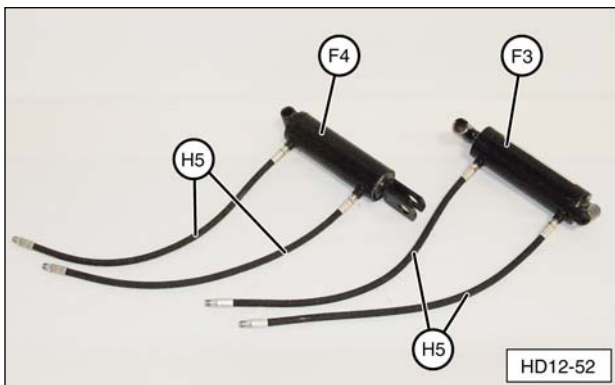

(F3) Forward Tilt cylinder. (F4) Side Tilt Cylinder.
(H5) Tilt Cylinder Hydraulic Hose.

6. Carefully clamp tilt cylinder (F3 or F4) mounting tube in a vise. Completely compress internal cylinder cap snap ring (F14) and pull cylinder rod assembly (F16 or F17) out of tilt cylinder tube (F21 or F27).

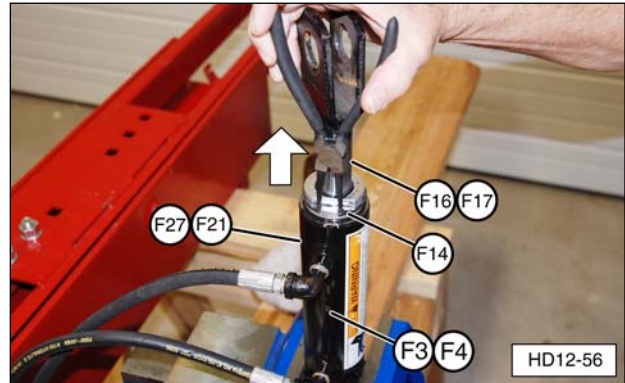

(F3, F4) Cylinder Assembly (forward or side tilt).
(F14) Cylinder Cap Snap Ring. (F16, F17) Cylinder Rod Assembly (forward or side tilt). (F21, F27) Cylinder Tube

7. Disassemble cylinder rod (F16, F17) by removing cylinder rod nut (F20), piston (F19), piston to cylinder rod seal (F18), and cylinder cap (F15) from the cylinder rod.

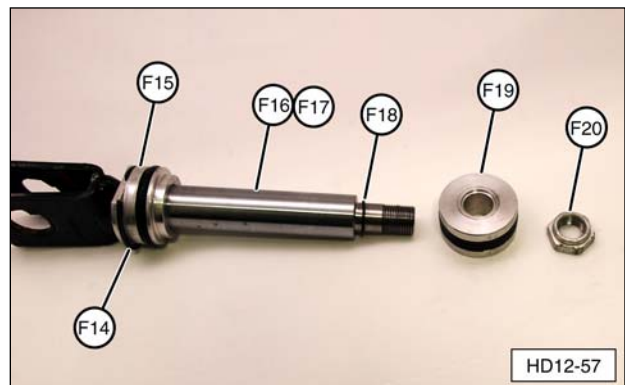

(F14) Snap Ring. (F15) Cylinder Cap. (F16 or F17) Cylinder Rod. (F18) Cylinder Rod Seal. (F19) Piston. (F20) Cylinder Rod Nut.

8. Inspect the cylinder rod sealing surface for any dents, bends, nicks, pitting, scratches, scoring, or rust. Replace any worn or damaged components.

9. Use a sturdy seal pick to remove the seals from the cylinder piston. Discard the seals. Clean and inspect the piston and replace if worn or damaged.
10. Clean the inside of the tilt cylinder tube and inspect for scratches with raised (above the surface level) edges, wear, rust, cracks, and pitting. Replace any worn or damaged tube.
11. Use a sturdy seal pick to remove the seals from the cylinder cap. Discard the seals. Clean and inspect the cap and replace if worn or damaged.

Cylinder Assembly

1. Make sure all tilt cylinder components are clean and free of rust.
2. Lubricate the new seals with clean hydraulic fluid.
3. Install new internal O-ring seal (F23) and lip seal (F24) (raised lip up) inside the cylinder cap. Install new O-ring seal (F22) in the O.D. groove. Install a new snap ring (F14), not shown, in the top "cut-a-way" groove.

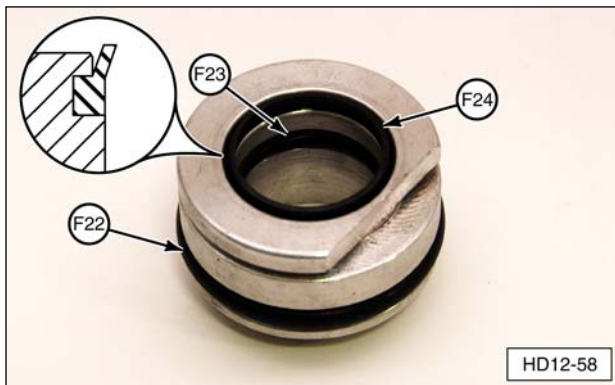

(F22) External O-ring Seal. (F23) Internal O-ring Seal.
(F24) Internal Lip Seal.

4. Install new scraper seal (F25) in the cylinder piston groove, followed by O-ring seal (F26), and second scraper seal (F25). The rounded (concave) surface of each scraper seal (F25) must face (contact) larger O-ring seal (F26).

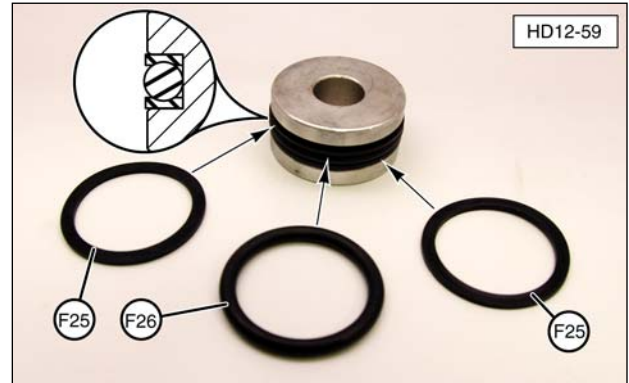

(F25) Scraper Seal. (F26) O-ring Seal.

5. Install new O-ring seal (F18) on the threaded end of cylinder rod (F16 or F17).
6. Lubricate the ID of cylinder cap (F15) with clean hydraulic oil and install the cap onto cylinder rod (F16 or F17) with the snap ring groove facing up (toward the cylinder rod mounting eye).
7. Lubricate the ID of cylinder piston (F19) with clean hydraulic oil. Install the cylinder piston on cylinder rod (F16 or F17) with the O-ring relief (groove) (A) toward O-ring seal (F18). Install new self locking nut (F20) and tighten securely.

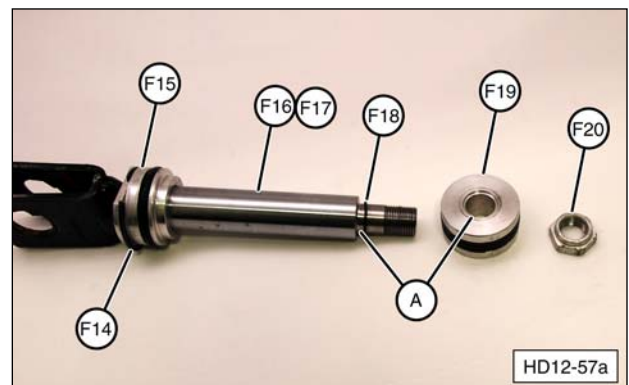

(F14) Snap Ring. (F15) Cylinder Cap.
(F16 or F17) Cylinder Rod. (F18) O-ring Seal.
(F19) Cylinder Piston (with seal). (F20) Self Locking Nut.

8. Lubricate cylinder tube (F21, F27) bore, piston (F19) seals, and cylinder cap (F15) seals. Install cylinder rod (F16, F17) assembly into the cylinder tube, being careful not to damage any seals.

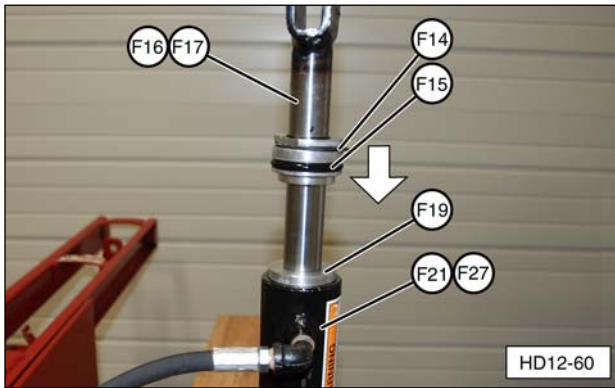

(F14) Snap Ring. (F15) Cylinder Cap.
 (F16, F17) Cylinder Rod. (F19) Cylinder Piston
 (with seal). (F21, F27) Cylinder Tube.

9. Push cylinder rod into cylinder tube until snap ring (F14) in cylinder cap (F15) contacts the top of the cylinder tube.
10. Use heavy-duty snap ring pliers to completely compress snap ring (F14). Push cylinder cap (F15) into cylinder tube (F21) until the snap ring is completely seated in the internal snap ring groove.

NOTE: It may be necessary to use a soft (brass or wood) drift to tap the cylinder cap and snap ring into place. Use caution not to damage the aluminum cylinder cap.

! WARNING



Make sure the snap ring is completely seated in the cylinder tube groove. Failure to seat the snap ring in the groove can cause the cylinder cap to be explosively ejected from the tilt cylinder tube when hydraulic pressure is applied, resulting in serious injury or even death.

11. Install tilt cylinder(s) (F3, F4) with appropriate mounting pins (F7, F8, and/or D6) and secure with Lynch pins (D7). Reconnect the hydraulic hoses.

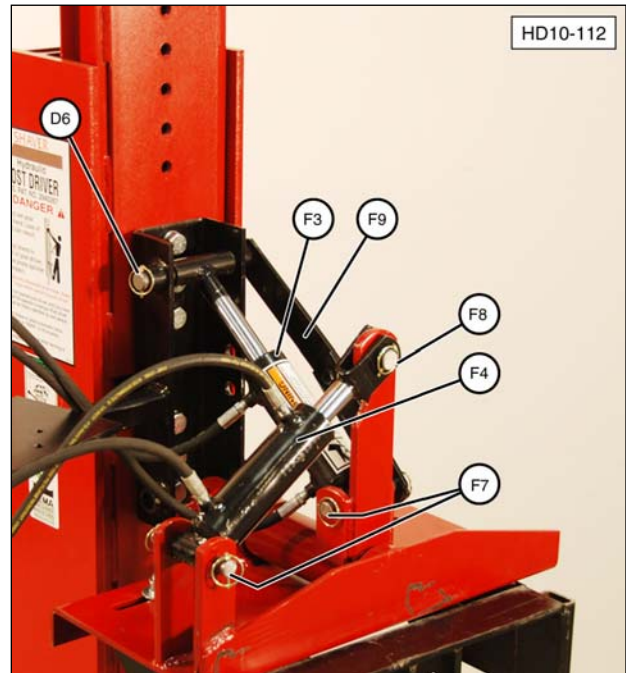

(D6) Short Channel Mounting Pin. (F3) Forward Tilt Cylinder. (F4) Side Tilt Cylinder. (F7) Mounting Pin. (F8) Short Mounting Pin.

Three-Point Hitch/Post Driver Assembly

1. With road lock pin (B8) installed in the lower hole of drive ram (A1), use a suitable overhead lifting device to raise (stand up) main carriage channel assembly (B1).

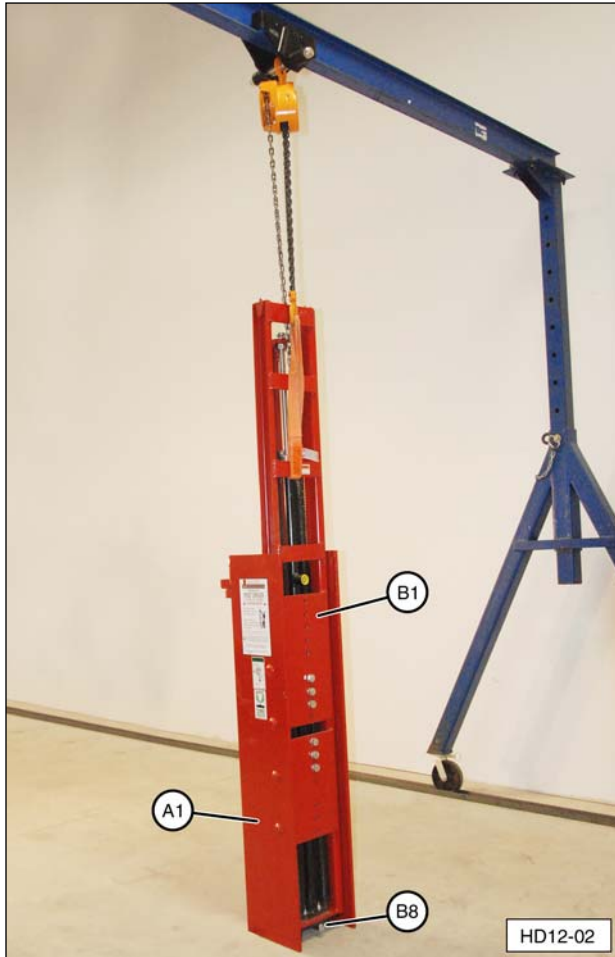

(A1) Drive Ram. (B1) Main Carriage Channel Assembly. (B8) Road Lock Pin.

! WARNING



The main carriage channel assembly is tall and heavy. To avoid tip over, resulting in serious injury or death, leave the overhead lifting device attached to the main carriage channel while assembling components.

2. For instructions on connecting the three-point hitch weldment and Post Driver assembly after service, refer to Step 6 in the Assembly Procedure, Base Plate section of this manual.
3. Apply paste-type thread sealant to the pipe thread hose fitting. Connect drive cylinder hose (G15) to drive cylinder assembly (C1). Tighten the hose fitting securely.

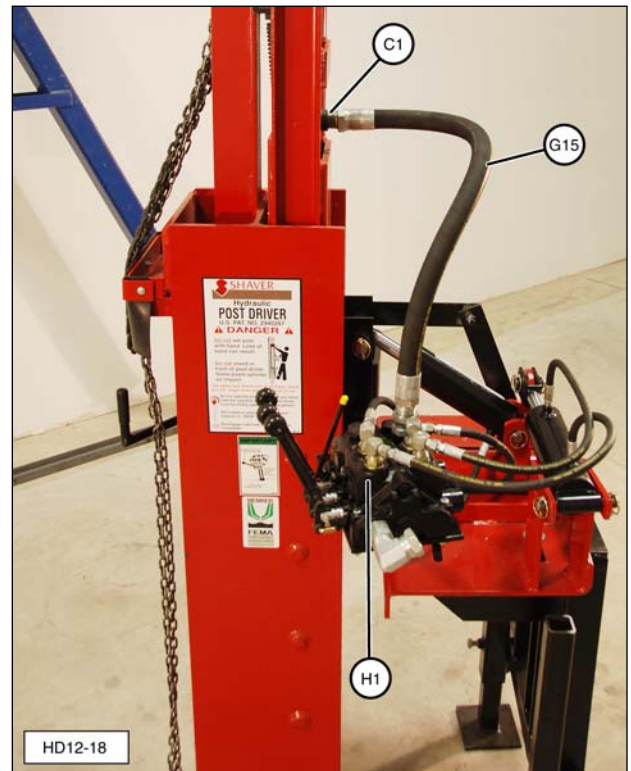

(C1) Drive Cylinder Assembly. (G15) Valve to Drive Ram Hose. (H1) Hydraulic Control Valve.

NOTE: Before using the Post Driver after service, it may be necessary to operate the hydraulic control valve levers a few times, to remove air from the hydraulic system.

Service Parts

Driver Assembly

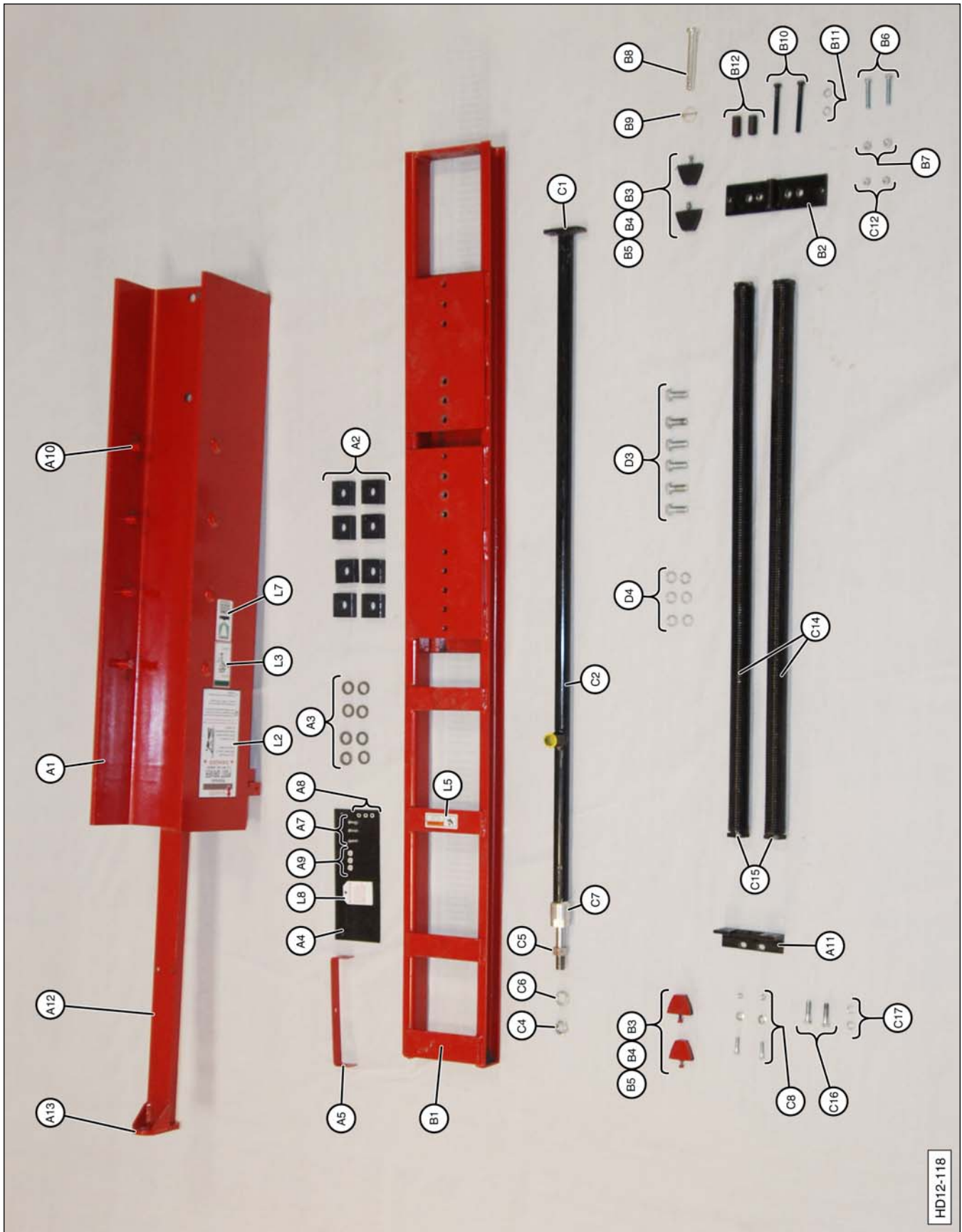

HD12-118

Driver Assembly

HD-12-H Service Parts - Driver Assembly			
Item No.	Part No.	Description	Qty.
A1	SM-1211-DRC	Driving Ram Complete	1
	SM-1211-DRO	Driving Ram Only	1
A2	SM-00512	Guide Block (Pkg. of 4)	2
A3	SM-0933-(18 ga)	Shim	4
	SM-0934-(14 ga)		
	SM-0935-(10 ga)		
A4	SM-1211-G	Rubber Debris Guard ¹	1
A5		Guard Mounting Strap	1
L8		Caution Tag	1
A7		Guard Mounting Bolt	3
A8		Guard Mounting Washer	3
A9		Guard Mounting Nut	3
A11	SM-1211-SBU	Upper Spring Bracket	1
B1	SM-12412	Main Carriage Channel	1
B2	SM-1241-RLB	Road Lock Bracket (no pin)	1
B3	SM-0041-B	Rubber Bumper ²	4
B4		Bumper Lock Washer, 5/16	4
B5		Bumper Nut, 5/16-18	4
B6	SM-093	Road Lock Bracket Bolt	2
B7	SM-0932	Road Lock Bracket Nut	2
B8	SM-1041-RLP	Road Lock Pin	1
B9	SM-1041-RLC	Road Lock Pin Clip	1
C1	SM-1026	Cylinder Assembly	1
C2	SM-10261	Cylinder Tube	1
C3	SM-10266	Cylinder Piston/Rod	1
C4	SM-10267	Piston Self-Locking Nut	1
C5	SM-018	Cylinder Nut (with setscrew)	1
C6	SM-10268	Lock Washer	1
C7	SM-10262-D	Cylinder Cap (with seal)	1

HD-12-H Service Parts - Driver Assembly (continued)			
Item No.	Part No.	Description	Qty.
C8	—	Bolts, Lock Washers, Nuts (upper spring bracket)	2
C12	SM-0931	Lower Bracket Lock Nut	2
C13	SM-1211-SCL	Spring Mount Lower	2
C14	SM-1211-DRS	Spring Complete (with spring mounts installed)	2
C15	SM-1211-SCU	Spring Mount Upper	2
C16	—	Upper Spring Mt. Bolt	2
C17	—	Upper Spring Mt. Washer	2
D3	S-012	Short Bracket Bolts 5/8-11 x 1-1/4	4
D4	S-013	Short Bracket Lock Washer 5/8	4
L2	MS-161	Large "SHAVER" Decal	1
L3	MS-169	Control Valve Decal	1
L5	MS-181	Pinch Area Warning Decal	1
L7	MS-280	FEMA Member Decal	1
L9	MS-180	Cylinder Shaft Loose Decal (not visible)	1

¹ SM-1211-G Includes Items A4, A5, L8, A7, A8, and A9.

² SM-0041-B Includes Items B3, B4, and B5.

Drive Ram Weldment Parts

HD-12-H Service Parts - Drive Ram Weldment			
Item No.	Part No.	Description	Qty.
A10	SM-1011-BS	Block Stud ¹	8
A12	SM-1211-LYB	Lift Yoke Bar ¹	1
A13	SM-1211-LYT	Lift Yoke Top ¹	1

¹ Replacement of these parts requires removal of old parts with a cutting torch and/or grinding wheel. New (replacement) parts must be welded to drive ram. This type of repair voids any warranties.

Hydraulic Base Plate Assembly

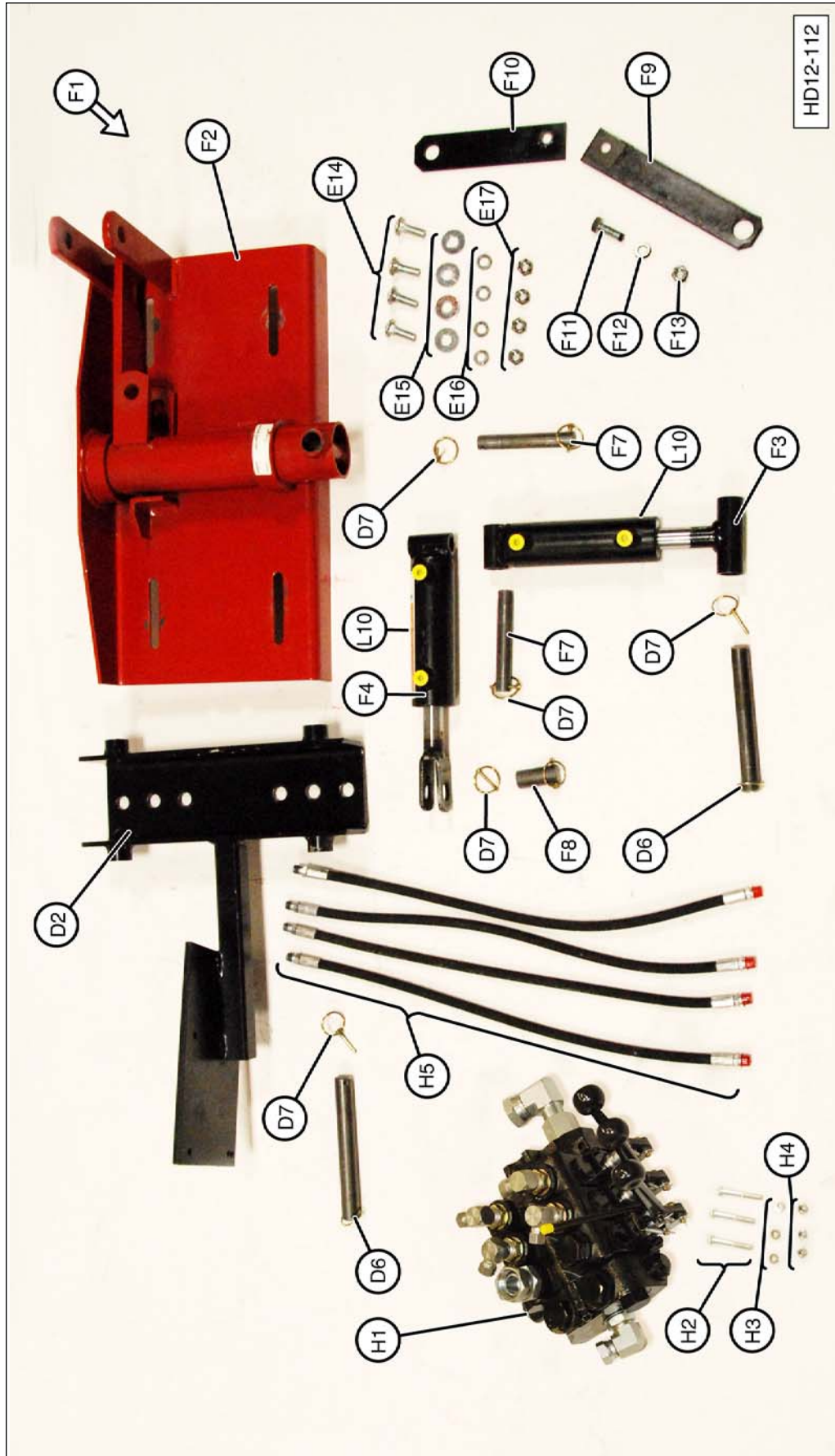

Hydraulic Base Plate Assembly

HD-12-H Service Parts - Hydraulic Base Plate Assembly			
Item No.	Part No.	Description	Qty.
D2	HBP-9129	Short Channel	1
D6	SM-014	Channel Mounting Pin	2
D7	SM-2025-LP	Lynch Pin	10
E14	—	Base Plate Mounting Bolt, 5/8-11 x 1-1/2 ⁴	4
E15	—	Base Plate Flat Washer, 5/8 ⁴	4
E16	—	Base Plate Lock Washer, 5/8 ⁴	4
E17	—	Base Plate Mounting Nut, 5/8-11 ⁴	4
F1	HBP-912111	Hydraulic Base Plate 2.5" diameter cylinders	1
F2	HBP-91211	Hydraulic Base Plate 2" diameter cylinders	1
F3/F4	HBP-912120	Cylinder Kit Carton ¹	1
F3	HBP-91217	2.5" Forward Tilt Cylinder ²	1
F4	HBP-91218	2.5" Side Tilt Cylinder ³	1
F5	HBP-912177	Cylinder Seal Kit, not shown	1
F7	HBP-908133	Cylinder Mounting Pin	2
F8	HBP-908134	Side Tilt Mounting Pin	1

HD-12-H Service Parts - Hydraulic Base Plate Assembly (continued)			
Item No.	Part No.	Description	Qty.
F9	—	Cylinder Stop Plate, 8.5 ^{1, 5}	1
F10	—	Cylinder Stop Plate, 10.5 ^{1, 5}	1
F11	—	Cylinder Stop Bolt, 1/2-13 x 1-3/4 ^{1, 5}	1
F12	—	Cylinder Stop Lock Washer, 1/2 ^{1, 5}	1
F13	—	Cylinder Stop Nut, 1/2-13 ⁴	1
H1	P-23	Hydraulic Control Valve	1
—	P-2012	Seal Kit for P-23 Valve Section not shown	3
H2	—	Valve Mounting Bolt, 5/16-18 x 3	3
H3	—	Valve Mounting Washer, 5/16	3
H4	—	Valve Mounting Nut, 5/16-18,	3
H5	SM-02111-P	Tilt Cylinder Hose	4
L10	MS-171	High-Pressure Warning Decal	2

¹ HBP-908120 Kit Includes Items F3, F4, and F9 Through F13.

² Replaces Obsolete 2" Forward Tilt Cylinder HBP-91209.

³ Replaces Obsolete 2" Side Tilt Cylinder HBP-91210.

⁴ S-1092 Kit Includes Items E14, E15, E16, and E17.

⁵ HBP-912-CS Kit Contains Items F9, F10, F11, F12, and F13.

NOTE: All hardware is Grade 5.

Three-Point Hitch Assembly

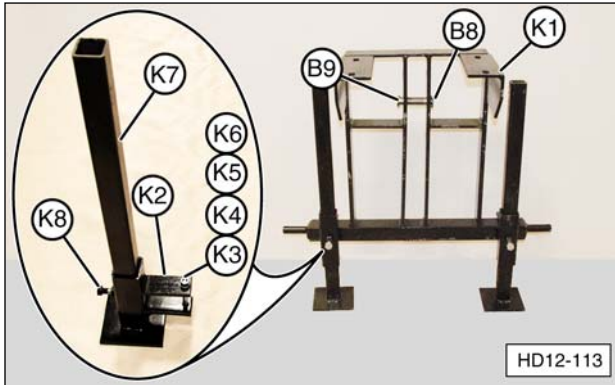

HD-12-H Service Parts - Three-Point Hitch Assembly

Item No.	Part No.	Description	Qty.
B8	MB-1201A-12	Upper Link Hitch Pin	1
B9	SM-2025-LP	Lynch Pin	1
K1	MB-1201-A	Three-Point Hitch Weldment	1
K2	OS-4-22-SFB	Leg Bracket Weldment ¹	2
K3	—	Leg Bracket Bolt, 1/2-13 x 4 ¹	2
K4	—	Leg Bracket Flat Washer, 1/2 ¹	2
K5	—	Leg Bracket Lock Washer 1/2 ¹	2
K6	—	Leg Bracket Nut, 1/2-13 ¹	2
K7	OS-4-22-SSA	Stabilizer Leg Only ¹	2
K8	—	Stabilizer Leg Lock Bolt, 5/8-11 x 1-1/2 ¹	2

¹ OS-4-22 Stabilizer Leg Kit Includes Items K2 Through K8.

Hydraulic Hoses

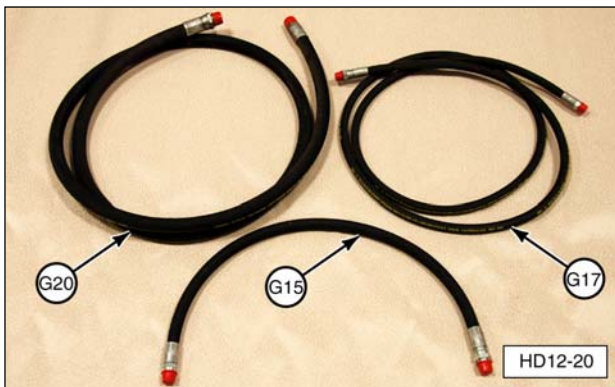

HD-12-H Service Parts - Hydraulic Hoses

Item No.	Part No.	Description	Qty.
G15	SM-1023-P	Valve to Drive Ram Hose ¹	1
G17	SM-0234-P	Power Supply to Valve Hose ²	1
G20	SM-1025-R	Valve to Tank Return Hose ³	1

¹ 1" ID x 35" long. ² 1/2" ID x 120" long. ³ 1" ID x 120" long.

Safety Arm Assembly

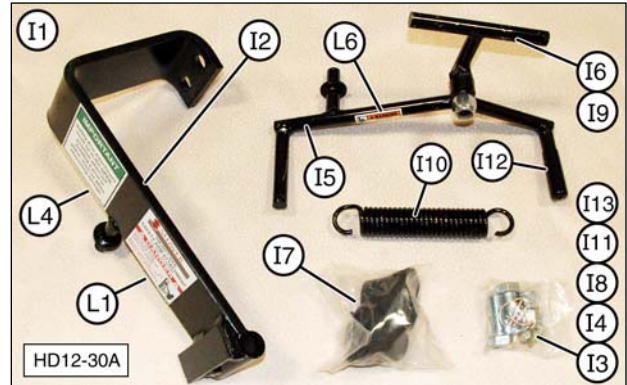

HD-12-H Service Parts - Safety Arm Assembly

Item No.	Part No.	Description	Qty.
I1	SM-0011-SAA	Safety Arm Attachment ¹	1
I2	SM-0011-SAAC	Safety Arm Frame	1
I3	—	Frame Mounting Bolt, 3/4-13 x 2	2
I4	—	Self-Locking Nut, 3/4-13	2
I5	SM-0011-SAAD	Swing Arm Handle	1
I6	SM-0011-SAA15	Roller Holder Swivel ²	1
I7	SM-0011-SAA16	Roller ²	2
I8	—	Roller Retainer Roll Pin ²	2
I9	—	Roller Bracket Nut, 3/4-13	1
I10	SM-0011-SAA2	Latch Spring	1
I11	SM-0011-SAA7	Flat Washer, 3/4	2
I12	SM-015-CC	Swing Arm Handle Cover	1
I13	SM-2025-LP	Lynch Pin, 3/16 x 1-7/8	3
L1	MS-165	Small "SHAVER" Decal	1
L4	MS-166	Safety Arm Decal	1
L6	MS-181	Pinch Area Warning Decal	1

¹ Complete Safety Arm Kit (Items I2 through L6).

² SM-0011-SAA13C Includes Items I6, I7, and I8.

Replacement Decals



HD-12-H Service Parts - Replacement Decals			
Item No.	Part No.	Description	Qty.
L1	MS-165	Small SHAVER Decal	1
L2	MS-161	Large SHAVER Decal	1
L3	MS-169	Control Valve Decal	1
L4	MS-166	Safety Arm Decal	1
L5	MS-163	Pinch Area Warning Decal	1
L6	MS-181	Pinch Point Warning Decal	1
L7	MS-280	FEMA Member Decal	1
L8	SM-0011-ST	Caution Tag	1
L9	MS-180	Cylinder Shaft Decal	1
L10	MS-171	High-Pressure Warning Decal	1

Document Storage Tube



HD-12-H Service Parts - Document Storage Tube			
Item No.	Part No.	Description	Qty.
J1	OPMAN	Document Storage Tube (with two rivets)	1

Hydraulic Control Valve

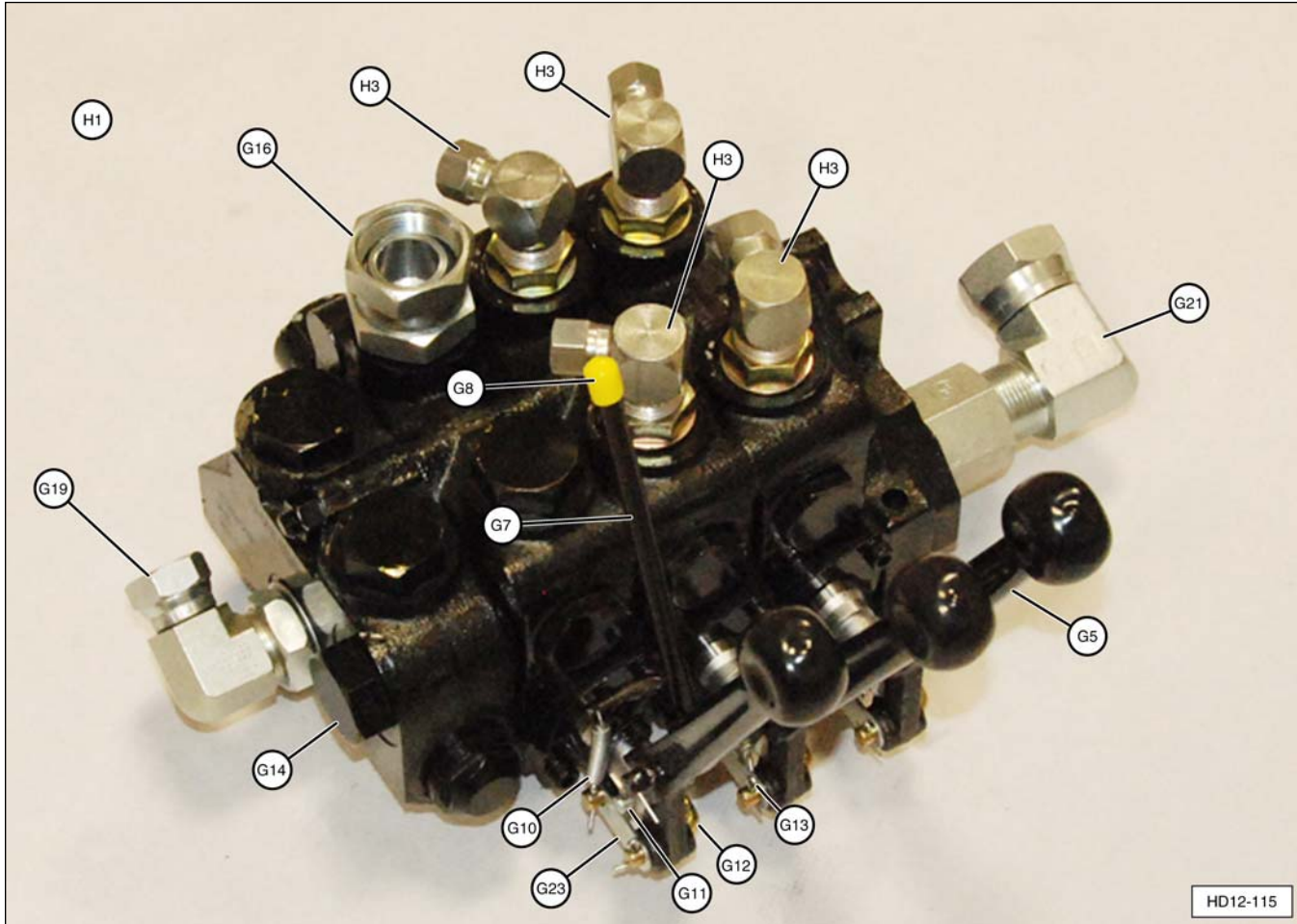

HD-12-H Service Parts - Hydraulic Control Valve

Item No.	Part No.	Description	Qty.
H1	P-23	Control Valve (Complete)	1
H3	P-910181	90° O-Ring Swivel Fitting (With Restrictor) 7/8-14 Male to 1/4 Female	4
G5	P-202	Control Valve Lever Only ^{1, 2}	3
G7	GS-001	Control Valve Safety Lever	1
G8	GS-001-2	Safety Lever Plastic Cap	1
G10	GS-001-3	Safety Lever Return Spring	1
G11	P-206	Lever Clevis Pin	3
G12	P-209	U-Link	3
G13	P-205	Cotter Pin	8
G14	P-207A	Open Center Plug Kit ³	1
G16	P-910182	O-Ring Swivel Fitting 3/4" Male x 1" Female	1
G19	P-910183	O-Ring Swivel 90° Fitting 1-1/16-12 Male to 1/2" Female	1

HD-12-H Service Parts - Hydraulic Control Valve (continued)

Item No.	Part No.	Description	Qty.
G21	P-910184	Pipe Thread Adapter Fitting 1-1/16"-12 O-Ring Male to 3/4" Pipe Thread Female	1
		90° Pipe Thread Swivel Fitting 3/4" Male to 1" NPT Female	1
G23	P-208	Flat Link	1
—	P-2012	Seal Kit for P-23 Valve ⁴	3

¹ P-201 Kit Includes Item G5, G11, G12, G13, and G23.

² P-202A Kit Includes Item G5, G7, G8, and G10.

³ Standard. Optional P207 Plug Kit required for "Closed Center" valve operation.

⁴ One P-2012 Seal Kit required for each section of P23 Valve.

Drive Cylinder Assembly

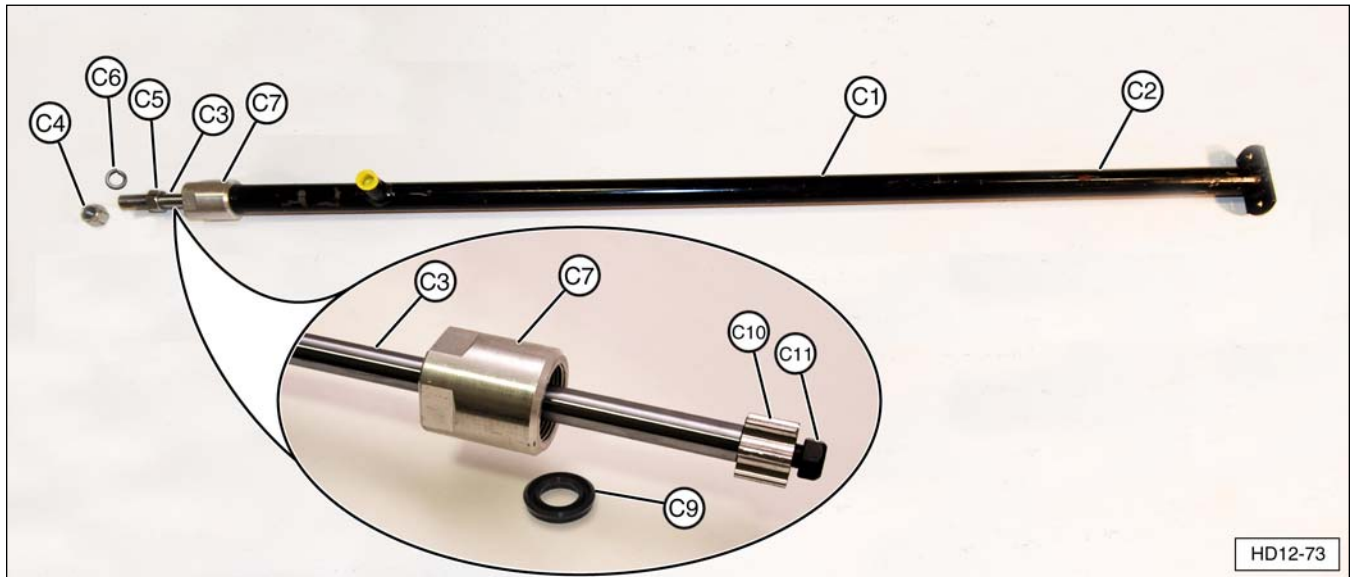

Expanded View Of Safety Lever Assembly

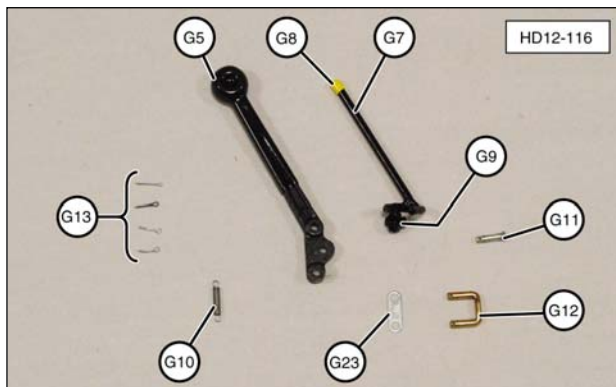

HD-12-H Service Parts - Drive Ram Cylinder Assembly

Item No.	Part No.	Description	Qty.
C1	SM-1026	Drive Ram Cylinder (complete)	1
C2	SM-10261	Drive Ram Cylinder Tube	1
C3	SM-10266	Drive Ram Cylinder Piston Rod	1
C4	SM-10267	Self-Locking Nut	1
C5	SM-018	Nut With Setscrew	1
C6	SM-10268	Spring Lock Washer	1
C7	SM-10262	Cylinder Cap With Seal	1
C9	SM-10265-D	Cylinder Cap Seal Only	1
C10	SM-02610	Piston Rod Guide	1
C11	SM-0269	Self-Locking Piston Guide Nut	1

HD-12-H Service Parts - Safety Lever Assembly Detail

Item No.	Part No.	Description	Qty.
G5	P-202	Control Valve Lever Only	1
G7	GS-001	Control Valve Safety Lever	1
G8	GS-001-2	Safety Lever Plastic Cap	1
G9	—	Safety Lever Stop Setscrew	1
G10	GS-001-3	Safety Lever Return Spring	1
G11	P-206	Lever Clevis Pin	3
G12	P-209	U-Link	3
G13	P-205	Cotter Pin	4
G23	P-208	Flat Link	1

Tilt Cylinder Assembly

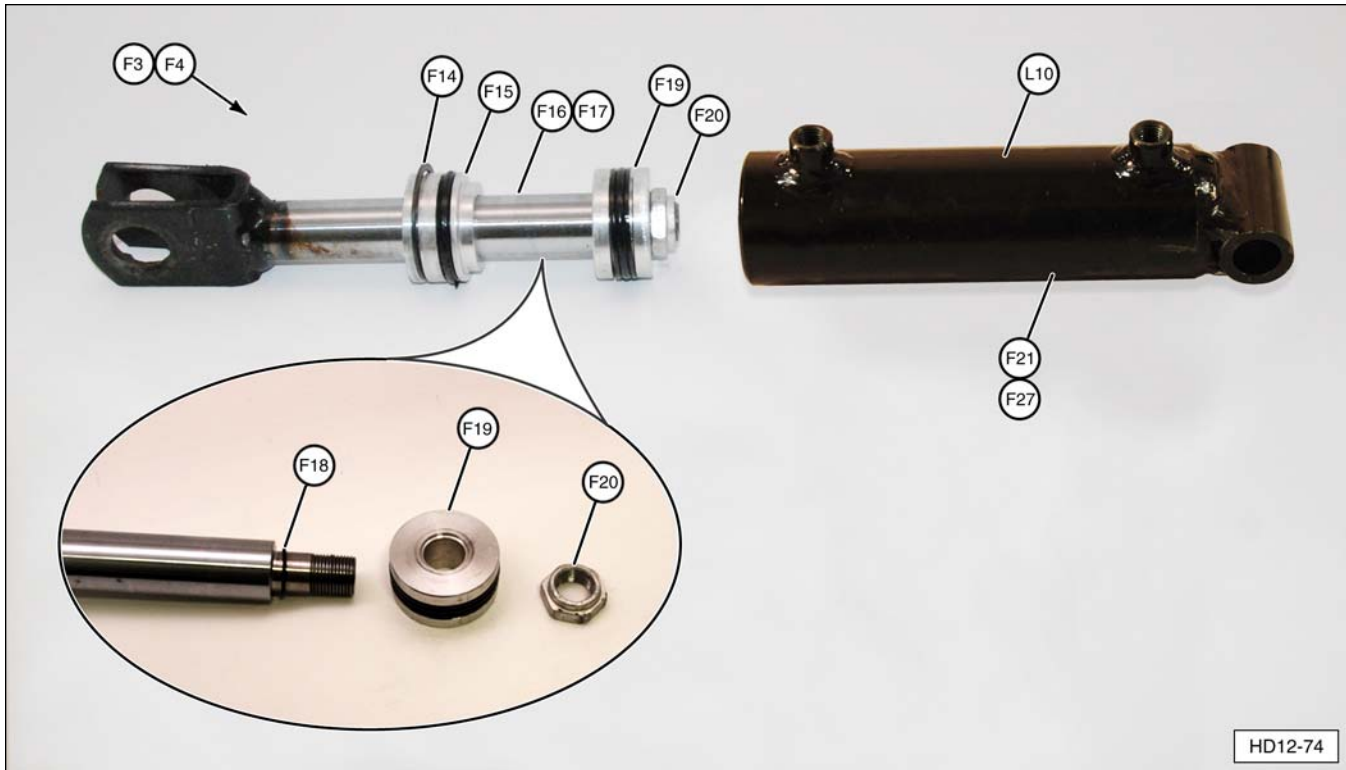

HD12-74

HD-12-H Service Parts - Fwd & Side Tilt Cylinder Assembly

Item No.	Part No.	Description	Qty.
F3	HBP-91217	2.5" Forward Tilt Cylinder ¹	1
F4	HBP-91218	2.5" Side Tilt Cylinder ¹	1
F5	HBP-912177	Cylinder Seal Kit not shown ²	1
F14	—	Snap Ring	1
F15	—	Tilt Cylinder Cap/Gland	1
F16	—	Side Tilt Cylinder Rod	1
F17	—	Forward Tilt Cylinder Rod	1
F18	—	O-Ring Seal	1
F19	—	Cylinder Piston	1
F20	—	Piston Rod Self-Locking Nut	1
F21	—	Fwd. Tilt Cylinder Tube Only	1
F22	—	External O-Ring Seal	1
F23	—	Internal O-Ring Seal	1
F24	—	Internal Lip Seal	1
F25	—	Scraper Seal	2
F26	—	O-Ring Seal	1
F27	—	Side Tilt Cylinder Tube Only	1
L10	MS-171	High-Pressure Warning Decal	1

¹ 2.5" Diameter Cylinders Replace Obsolete 2" Diameter HBP-91209 Fwd Tilt Cylinder and HBP-91220 Side Tilt Cylinder.

² Includes Item F18, F22, F23, F24, F25, and F26. (one seal kit required per cylinder.)

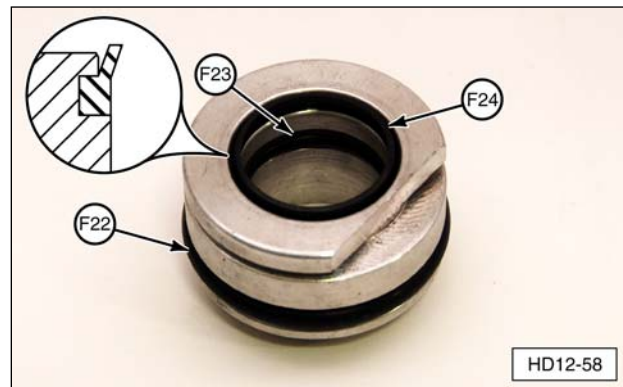

HD12-58

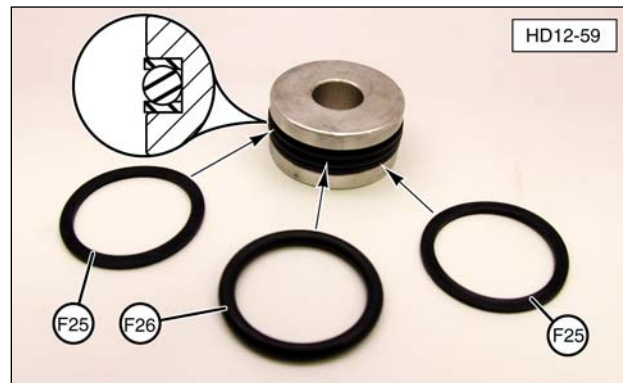

HD12-59



Shaver Manufacturing Co., LLC.
103 South Washington Avenue
P.O. Box 358
Graettinger, IA 51342
Phone: (712) 859-3293
Fax: (712) 859-3294
sales@shavermfg.com

Limited Warranty

Shaver Manufacturing Company, LLC warrants each new Shaver product to be free from defects in material and workmanship. This warranty is applicable only for the normal service life expectancy of the product or components, not to exceed 12 consecutive months from the date of delivery of the new Shaver product to the original purchaser.

Genuine Shaver replacement parts and components will be warranted for 90 days from the date of purchase, or the remainder of the original equipment warranty period, whichever is longer.

Rubber Bumpers, Carbide Teeth, Auger Teeth and Auger Points are usable parts and not covered by warranty. Part No. SD-101-GB and SD-0301-GB Gearbox are warranted for 3 years from the date of purchase. Part No. SD-0607-GB and SD-0907-GB Gearbox are warranted for 5 years from the date of purchase. Part No. SL-2030-1 5" Cylinder for the Logsplitter is warranted for 4 years from the date of purchase. Driving Ram Springs are warranted for 60 days from the date of purchase for residential customers and 30 days from the date of purchase with a limit of 2 claims per serial numbered unit for commercial users. Tires are warranted for 90 days from the date of purchase.

Under no circumstances will it cover any merchandise or components thereof, which, in the opinion of the company, have been subjected to misuse, unauthorized modification, alteration, an accident, or if a repair has been made with parts other than those obtainable through Shaver.

Our obligation under this warranty shall be limited to repairing or replacing any part that, in our judgment, shall show evidence of such defect, provided further that such part shall be returned within thirty (30) days from the date of failure to Shaver, routed through the dealer and distributor from whom the purchase was made, transportation charges prepaid. All returned items must have an RGA number. Contact Shaver at 712-859-3293 to get authorization to return, file your warranty claim and, if needed, an RGA will be provided.

This warranty shall not be interpreted to render Shaver liable for injury or damages of any kind or nature to person or property. This warranty does not extend to the loss of crops, loss because of delay in harvesting, or any expense or loss incurred for labor, substitute machinery, rental, or for any other reason.

Except as set forth above, **Shaver shall have no obligation or liability of any kind on account of any of its equipment and shall not be liable for special or consequential damages. Shaver makes no other warranty, expressed or implied, and specifically, Shaver disclaims any implied warranty of merchantability or fitness for a particular purpose. Some states or provinces do not permit limitations or exclusions of implied warranties or incidental or consequential damages, so the limitations or exclusion in this warranty may not apply.**

This warranty is subject to any existing conditions of supply which may directly affect our ability to obtain materials or manufacture replacement parts.

Shaver reserves the right to make improvements in design or changes in specifications at any time, without incurring any obligation to owners of units previously sold.

No one is authorized to alter, modify, or enlarge this warranty, nor the exclusion, limitations, and reservations.

Effective January 1, 2009

Warranty Card

The Post Driver is shipped from the factory with a warranty card. If the card is lost or misplaced, please copy this page, fill in the information, and send it to Shaver Manufacturing Company.

Warranty Card

Please complete the warranty card and return to:

Shaver Manufacturing Company
103 South Washington Avenue
P.O. Box 358
Graettinger, Iowa 51342

Name _____

Address _____

City _____ State _____ Zip Code _____

Purchase / Deliver Date _____

Shaver Model Number _____

Serial Number _____

Notes

