

AGRICULTURAL MACHINERY
sitrex®
Spa

SPARE PARTS LIST

MK/18 - MK/20

TABLE NO. 920.149 REAR PART

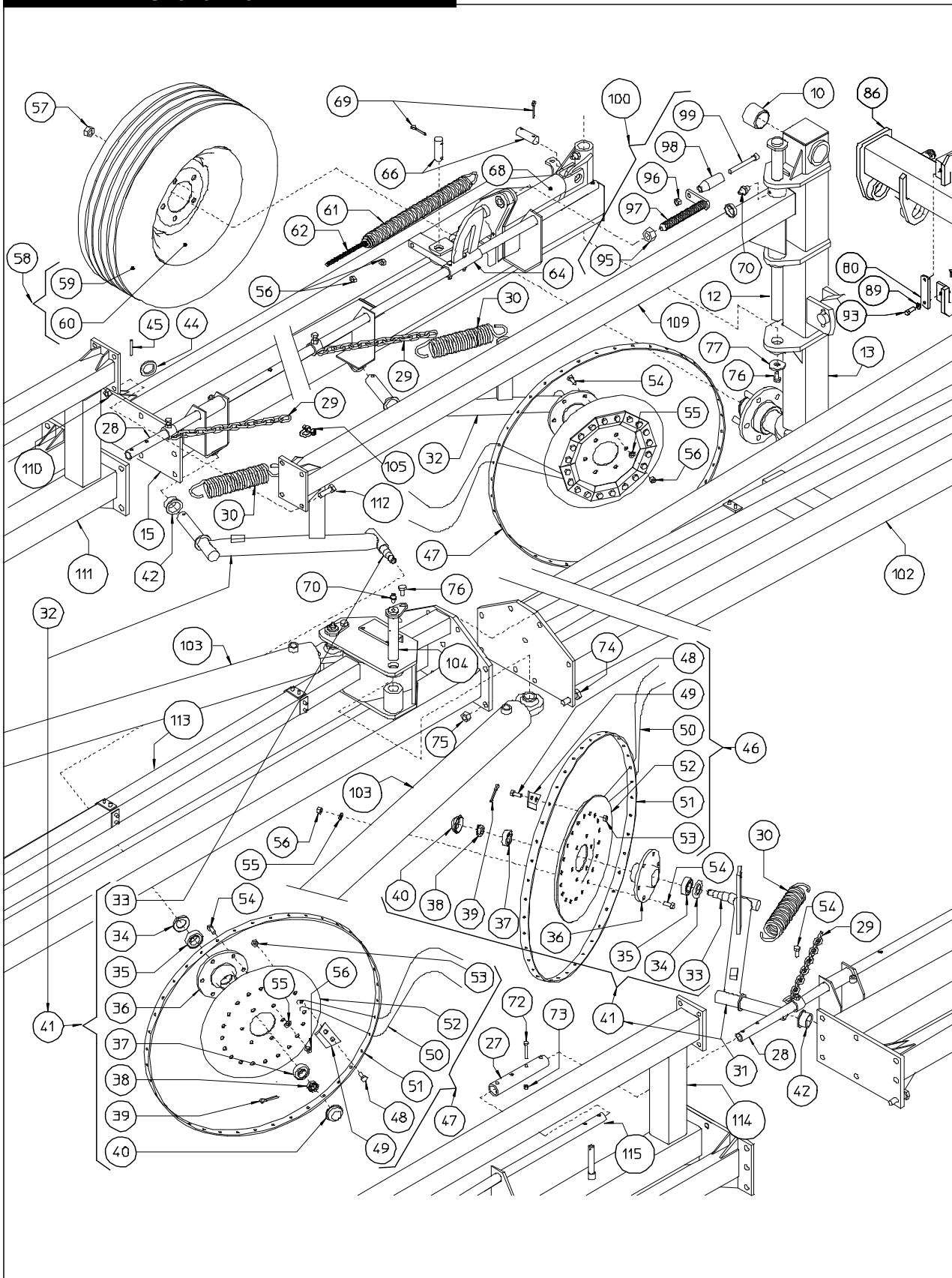

TABLE NO. 920.149 REAR PART

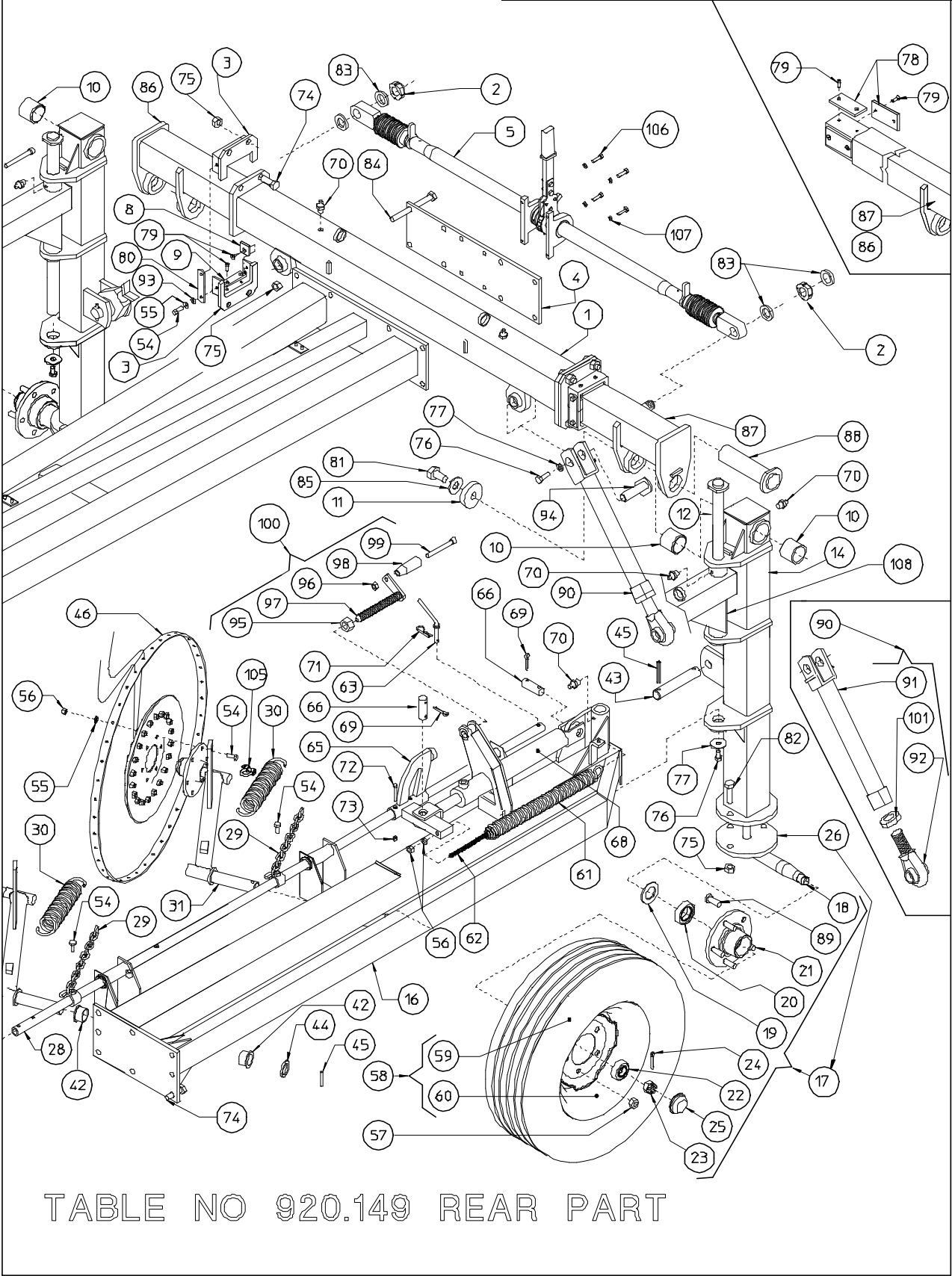
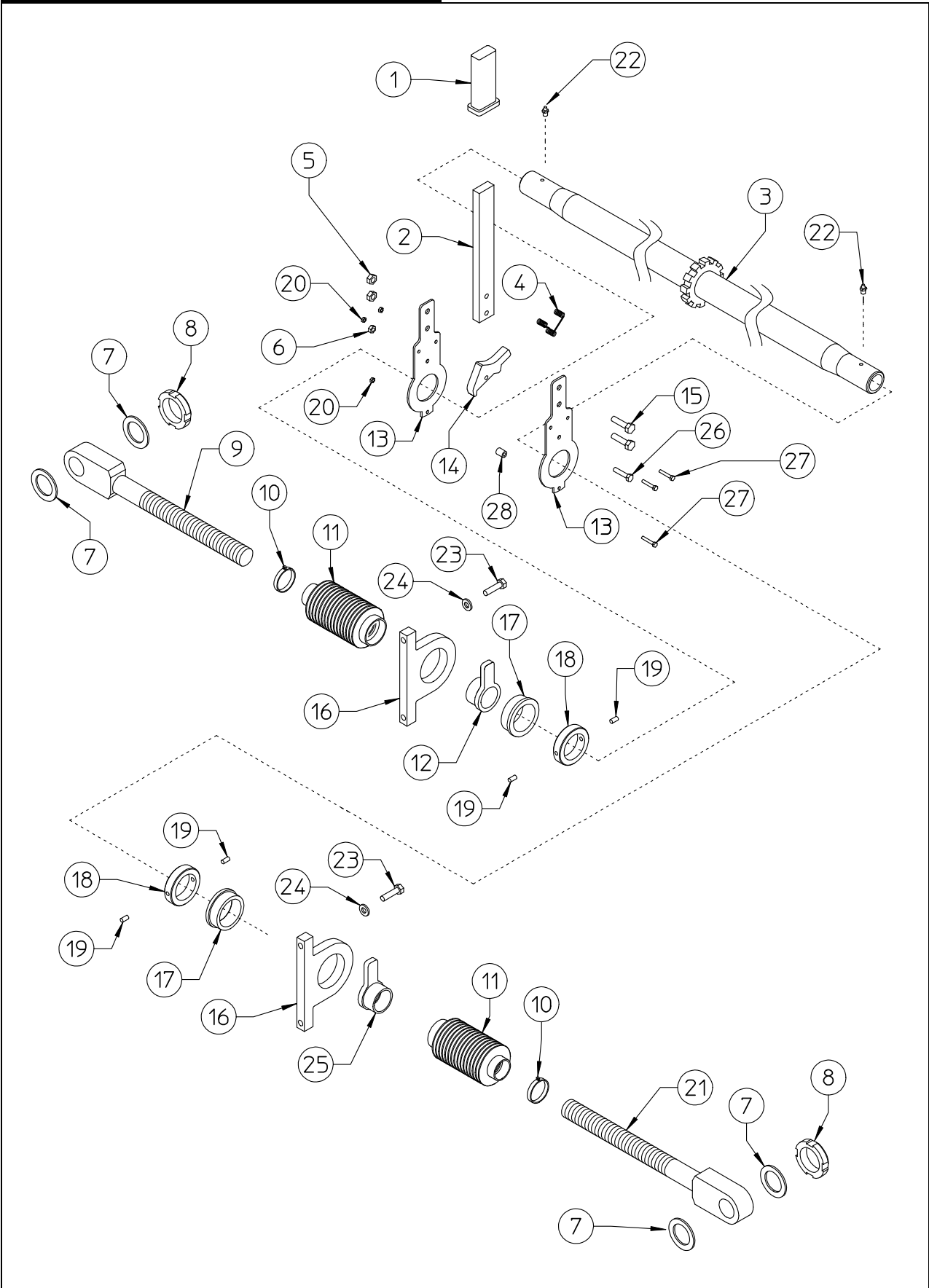

TABLE NO 920.149 REAR PART

TABLE NO 920.149 REAR PART					
ITEM	Q.ty MK18	Q.ty MK20	PART NO	DESCRIPTION	NOTE
1	1	1	220.177	OUTER CROSSPIECE	
2	2	2	610.593	LOCK-NUT M30 X 1,5	*
3	4	4	220.042	SLIDING SUPPORT	
4	1	1	220.176	DRAWBAR FIXING COUNTER PLATE	
5	1	1	210.981	RATCHET LINK	*
6	2	2	220.526	CYLINDER LOCKING PLATE	
7	4	4	600.735	SCREW M8 X 65 DIN 931 8.8	
8	8	8	210.912	SLIDING	
9	4	4	210.911	SLIDING	
10	12	12	200.199	BUSH	
11	2	2	200.822	WASHER	
12	2	2	210.247	PIN	
13	1	1	220.185	REAR WHEEL SUPPORT,RH	
14	1	1	220.186	REAR WHEEL SUPPORT,LH	
15	1	1	230.069	SECTION 2 WHEEL,RH	
16	1	1	230.070	SECTION 2 WHEEL,LH	
17	2	2	215.782	HUB ASSY	
18	2	2	220.443	PIN	
19	2	2	600.284	DUST COVER	
20	2	2	600.285	BEARING 30208	
21	2	2	600.286	HUB WITH SCREWS	
22	2	2	600.287	BEARING 30206	
23	2	2	600.288	CASTLE NUT M27 X 1,5	
24	2	2	600.291	SPLIT PIN	
25	2	2	600.290	CAP	
26	2	2	200.784	HUB ASSY	
27	6	8	220.357	BUSH	
28	2	2	220.350	MAIN PIPE	
29	18	20	220.356	CHAIN BUSH	
30	18	20	200.046	SPRING	
31	9	10	200.803	LH ARM	
32	9	10	200.008	RH ARM	
33	18	20	205.277	PIN	
34	18	20	600.011	DUST COVER	
35	18	20	600.012	BEARING 30205	
36	18	20	600.013	HUB	
37	18	20	600.014	BEARING 30204	
38	18	20	600.015	CASTLE NUT M18 X 1,5 - 6	
39	18	20	600.301	SPLIT PIN D 3 X 30 DIN 94 3.6	
40	18	20	600.016	CAP	
41	18	20	205.041	HUB ASSY	
42	36	40	200.029	BUSH	
43	2	2	220.191	PIN	
44	36	40	200.028	WASHER	
45	18	20	600.027	SPRING PIN D 8 X 50 DIN 1481	
46	9	10	210.181	LH FINGER WHEEL ASSY	
47	9	10	210.180	RH FINGER WHEEL ASSY	
48	360	400	600.005	SCREW M10 X 25 DIN 603 6.8	
49	180	200	200.012	TINE LOCK	
50	720	800	210.621	TINE	
51	18	20	200.009	RIM	
52	18	20	200.010	FLANGE	
53	360	400	600.029	NUT M10 DIN 980	
54	142	156	600.006	SCREW M10 X 25 DIN 933 8.8	
55	104	116	600.024	SPRING WASHER D 10,5	
56	100	112	600.010	NUT M10 DIN 934 - 8	
57	30	30	600.289	NUT M16 X1,5	
58	6	6	600.281	WHEEL ASSY	
59	6	6	600.303	TIRE	

TABLE NO 920.149 REAR PART					
ITEM	Q.ty MK18	Q.ty MK20	PART NO	DESCRIPTION	NOTE
60	6	6	600.304	RIM	
61	2	2	210.152	SPRING	
62	2	2	210.173	TIEROD	
63	2	2	220.377	PIN	
64	1	1	220.358	RH SUPPORT	
65	1	1	220.359	LH SUPPORT	
66	4	4	200.032	PIN	
67	36	40	600.968	GREASE NIPPLE M 6 - 45°	
68	2	2	210.150	CYLINDER	
69	8	8	600.038	SPLIT PIN D 6 X 35 DIN 94 3.6	
70	16	16	600.034	GREASE NIPPLE M8	
71	13	13	600.019	PIN	
72	28	36	610.525	SCREW M 8 X 60 DIN 931 8.8	
73	34	38	600.076	NUT M 8 DIN 980	
74	56	64	610.167	SCREW M16 X 45 DIN 933 8.8	
75	78	82	600.080	NUT M16 DIN 980	
76	18	14	600.770	SCREW M12 X 20 DIN 933 8.8	
77	14	12	500.160	FLAT WASHER	
78	8	8	210.858	SLIDING	
79	32	32	610.663	SCREW M8 X 16 DIN 7991 8.8	
80	4	4	220.043	LINKING PLATE	
81	2	2	600.150	SCREW M22 X 50 DIN 933 8.8	
82	6	6	600.384	SCREW M16 X 50 DIN 933 8.8	
83	4	4	220.208	SHIM	*
84	8	8	610.839	SCREW	
85	2	2	600.214	SPRING WASHER D 23 DIN 127B	
86	1	1	210.830	RH INNER CROSSPIECE	
87	1	1	210.831	LH INNER CROSSPIECE	
88	2	2	210.100	PIN	
89	10	10	610.413	SCREW M16 X 1,5 X 50	
90	2	2	210.833	TIE ROD, COMPLETE	
91	2	2	220.222	TIE ROD PIPE	
92	2	2	220.223	TIE ROD HEAD	
93	8	8	600.322	WASHER D 10,5 DIN 433	
94	2	2	220.209	PIN	
95	2	2	600.200	NUT M22 DIN 934 - 8	
96	2	2	600.008	NUT M12 DIN 934 - 8	
97	2	2	210.177	HANDLE	
98	2	2	600.965	KNOB	
99	2	2	600.967	SCREW M12 X100 DIN 912 8.8	
100	2	2	210.178	HANDLE, COMPLETE	
101	2	2	610.813	NUT M30 DIN 936	
102	1	1	220.175	REAR DRAWBAR	
103	2	2	210.215	CYLINDER	
104	2	2	210.134	PIN	
105	18	20	610.317	"D" SHACKLES	
106	4	4	600.757	SCREW M8 X 30 DIN 933 8.8	*
107	4	4	600.229	SPRING WASHER D 8,5	*
108	1	1	210.737	L.H. REINFORCEMENT	
109	1	1	210.736	R.H. REINFORCEMENT	
110	24	24	600.075	NUT M14 DIN 980	
111	1	1	230.071	SECTION 2 R.H. WHEEL	
112	16	16	600.752	SCREW M14 X 45 DIN 931 8.8	
113	1	1	210.925	DRAWBAR	
114	1	1	230.072	SECTION 2 L.H. WHEEL	
115	4	4	220.354	PIPE	
116	2	2	600.124	GREASE NIPPLE M6	
117	1	1	220.378	SPRING	
*	1	1	220.260	RATCHET LINK, KIT COMPLETE	

RATCHET LINK PART NO. 220.260



RATCHET LINK PART NO. 220.260				
ITEM	Q.ty	PART NO	DESCRIPTION	NOTE
1	1	610.811	HANDLE	*
2	1	220.213	LEVER	*
3	1	220.182	SCREW PIPE	*
4	1	220.073	SPRING	*
5	2	600.076	NUT M8 DIN 980	*
6	1	600.472	NUT M6 DIN 980	*
7	4	220.208	SHIM	
8	2	610.593	LOCK-NUT M30 X 1.5	
9	1	220.193	TIE ROD RH	*
10	2	610.507	RING	*
11	2	220.192	RUBBER COVER	*
12	1	220.201	LOCKING BUSH RH	*
13	2	220.205	LEVER SUPPORT	*
14	1	220.070	LOCKING HOOK	*
15	2	600.702	SCREW M8 X 25 DIN 933 8.8	*
16	2	220.195	PIPE SUPPORT	*
17	2	220.196	NYLON BUSH	*
18	2	220.206	BUSH	*
19	4	600.107	SPRING PIN D 6 X 18 DIN 1481	*
20	3	610.718	NUT M4 DIN 982 - 8	*
21	1	220.194	TIE ROD LH	*
22	2	600.124	GREASE NIPPLE M6	*
23	2	600.757	SCREW M8 X 30 DIN 933 8.8	
24	2	600.229	SPRING WASHER	
25	1	220.202	LOCKING BUSH LH	*
26	1	600.202	SCREW M6 X 25 DIN 933 8.8	*
27	3	610.717	SCREW M4 X 25 DIN 933 8.8	*
28	3	220.215	BUSH	*
*	1	210.981	RATCHET LINK	

TABLE NO. 920.204 CENTRAL PART

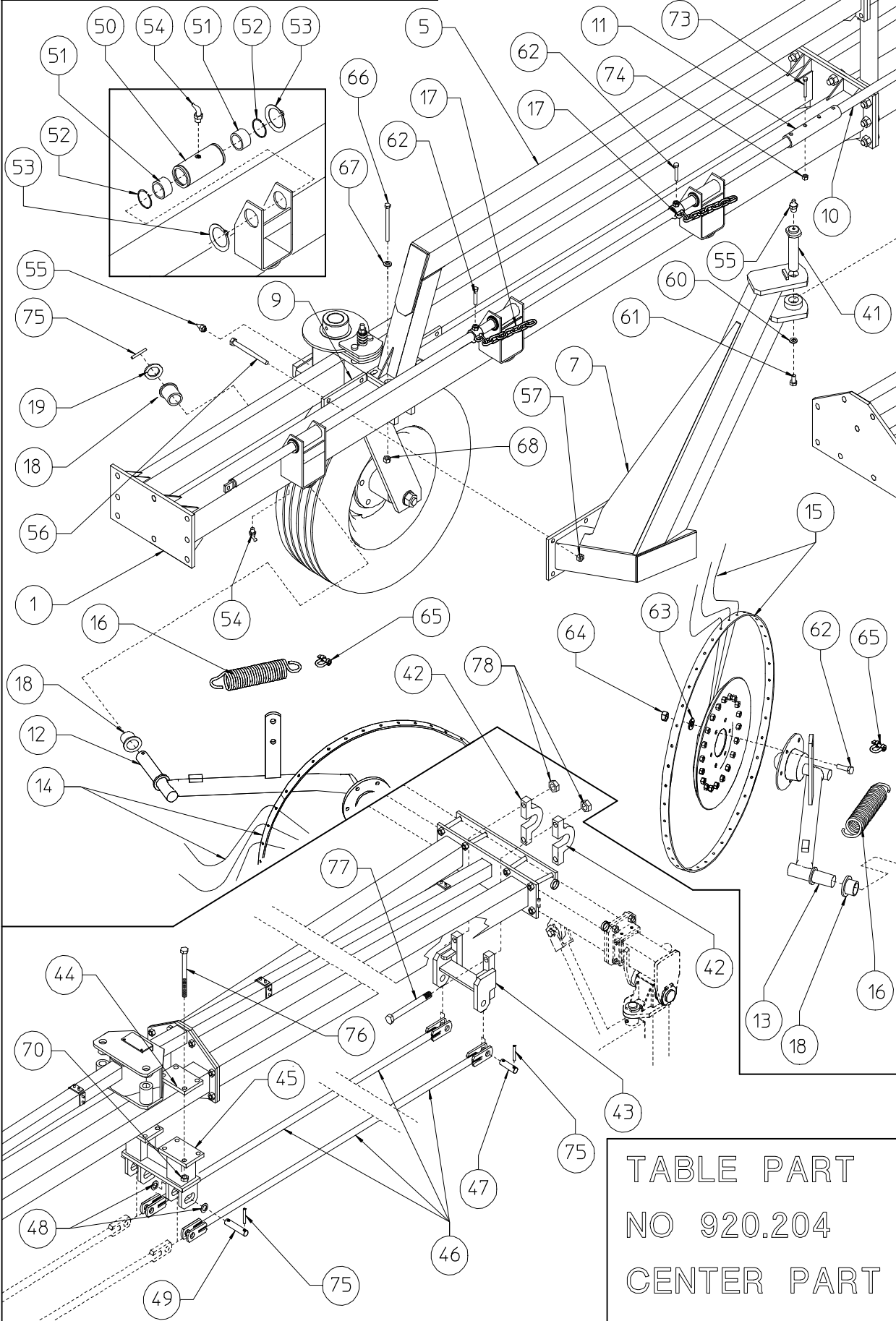

TABLE NO. 920.140 CENTRAL PART

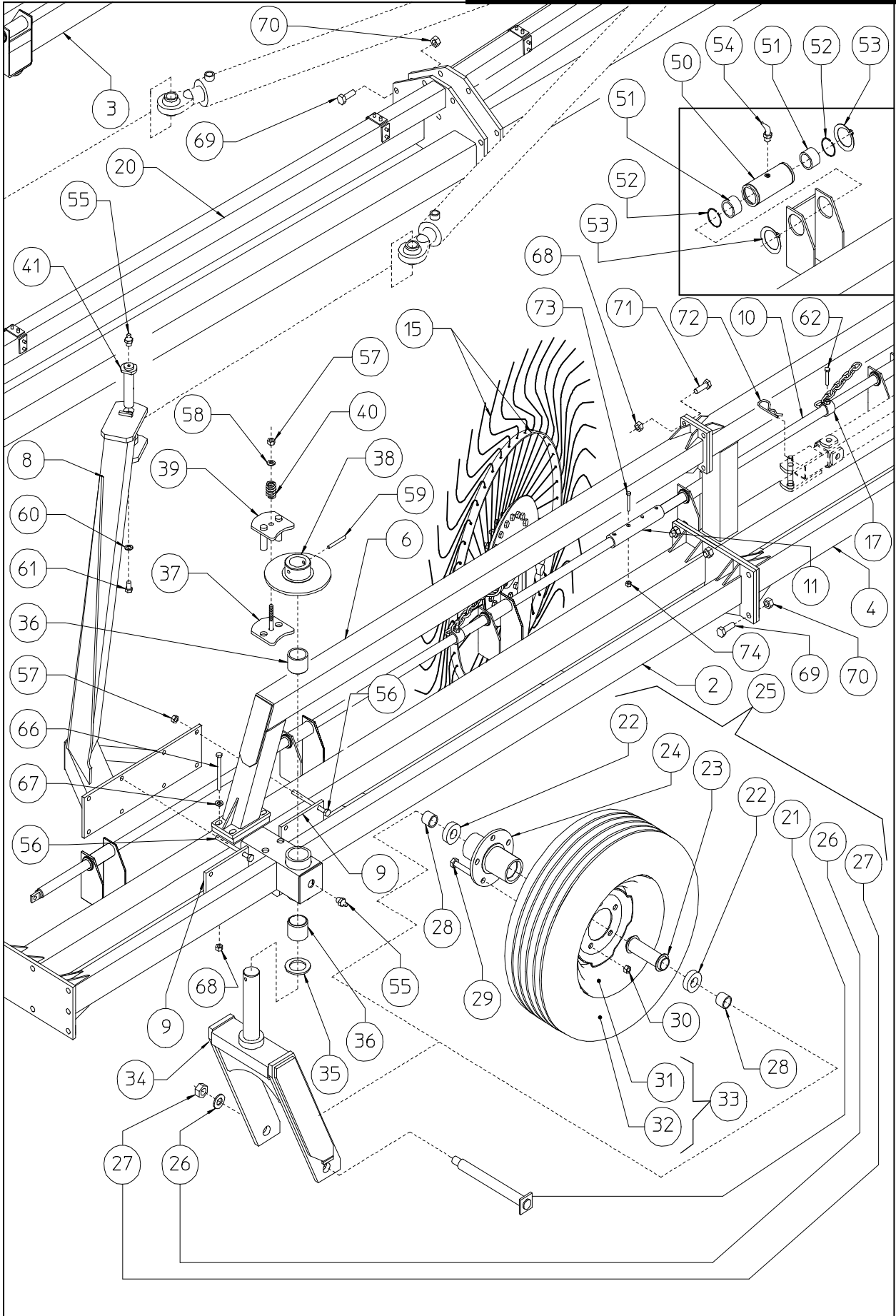

TABLE PART NO 920.204 - CENTER PART					
ITEM	MK/18 Q.ty	MK/20 Q.ty	PART NO	DESCRIPTION	NOTE
1	1	1	230.073	SECTION 3 RH WHEEL	
2	1	1	230.074	SECTION 3 LH WHEEL	
3	1	1	230.071	SECTION 2 RH WHEEL	
4	1	1	230.072	SECTION 2 LH WHEEL	
5	1	1	210.738	RH REINFORCEMENT	
6	1	1	210.739	LH REINFORCEMENT	
7	1	1	210.840	RH ARM	
8	1	1	210.841	LH ARM	
9	4	4	200.774	COUNTERPLATE	
10	2	2	220.354	PIPE	
11	2	2	220.357	BUSH	
12	5	5	200.008	RH ARM	
13	5	5	200.803	LH ARM	
14	5	5	210.180	RH FINGER WHEEL, ASSY	
15	5	5	210.181	LH FINGER WHEEL, ASSY	
16	10	10	200.046	SPRING	
17	10	10	220.356	CHAIN BUSH	
18	20	20	200.029	BUSH	
19	10	10	200.028	WASHER	
20	1	1	220.376	DRAWBAR	
21	2	2	210.184	PIN	
22	4	4	600.609	BEARING (6206 2RS)	
23	2	2	200.140	SPACER	
24	2	2	200.139	HUB	
25	2	2	210.169	HUB, ASSY	
26	2	2	200.165	WASHER	
27	2	2	600.079	NUT (M22 DIN 980)	
28	4	4	210.170	SPACER	
29	10	10	600.144	SCREW (M16x1,5x40 DIN 961)	
30	10	10	600.289	SPECIAL NUT M16x1,5	
31	2	2	600.304	RIM	
32	2	2	600.303	TIRE	
33	2	2	600.281	WHEEL ASSY (205/75-R15)	
34	2	2	230.080	SUPPORT	
35	2	2	210.179	SHIM	
36	4	4	200.199	BUSH	
37	2	2	210.931	BRAKE COUNTER PLATE	
38	2	2	200.025	FLANGE	
39	2	2	200.810	BRAKE	
40	2	2	200.044	SPRING	
41	2	2	210.135	PIN	
42	2	2	220.850	SUPPORT	
43	1	1	220.851	SUPPORT	
44	2	2	220.853	COUNTERPLATE	
45	1	1	220.852	SUPPORT	
46	2	2	220.855	TIE-ROD	
47	2	2	220.859	PIN	
48	4	4	220.208	SHIM	
49	2	2	220.860	PIN	
50	10	10	220.343	STEEL BUSH	
51	20	20	220.342	NYLON BUSH	
52	20	20	610.898	ELASTIC RIM (SB 44)	

TABLE PART NO 920.204 - FRONT PART					
ITEM	MK/18 Q.ty	MK/20 Q.ty	PART NO	DESCRIPTION	NOTE
53	20	20	610.833	SNAP RING (E 50)	
54	20	20	600.968	GREASE NIPPLE (M6x45°)	
55	4	4	600.034	GREASE NIPPLE (M8)	
56	16	16	600.001	SCREW (M12x140 DIN 931)	
57	18	18	600.077	NUT (M12 DIN 980)	
58	2	2	600.092	WASHER (ø13/36x2,5)	
59	2	2	600.033	SPRING PIN (ø10x80 DIN 1481)	
60	2	2	500.160	WASHER	
61	2	2	600.770	SCREW (M12x20 DIN 933)	
62	70	70	600.006	SCREW (M10x25 DIN 933)	
63	60	60	600.024	SPRING WASHER (ø13 DIN 127B)	
64	60	60	600.010	NUT (M10 DIN 934)	
65	10	10	610.317	"D" SACKLES	
66	8	8	610.908	SCREW (M14x160 DIN 931)	
67	8	8	600.188	WASHER (ø15)	
68	16	16	600.075	NUT (M14 DIN 980)	
69	17	17	610.167	SCREW (M16x45 DIN 933)	
70	25	25	600.080	NUT (M16 DIN 980)	
71	8	8	600.752	SCREW (M14x45 DIN 931)	
72	4	4	600.019	SPLIT PIN (ø3)	
73	8	8	610.525	SCREW (M8x60 DIN 931)	
74	8	8	600.076	NUT (M8 DIN 980)	
75	18	18	600.027	SPRING PIN (ø8x50 DIN 1481)	
76	8	8	600.219	SCREW (M16x150 DIN 931)	
77	4	4	620.256	SCREW (M24x260)	
78	4	4	620.255	NUT (M24 DIN 980)	

TABLE NO. 920.205 FRONT PART

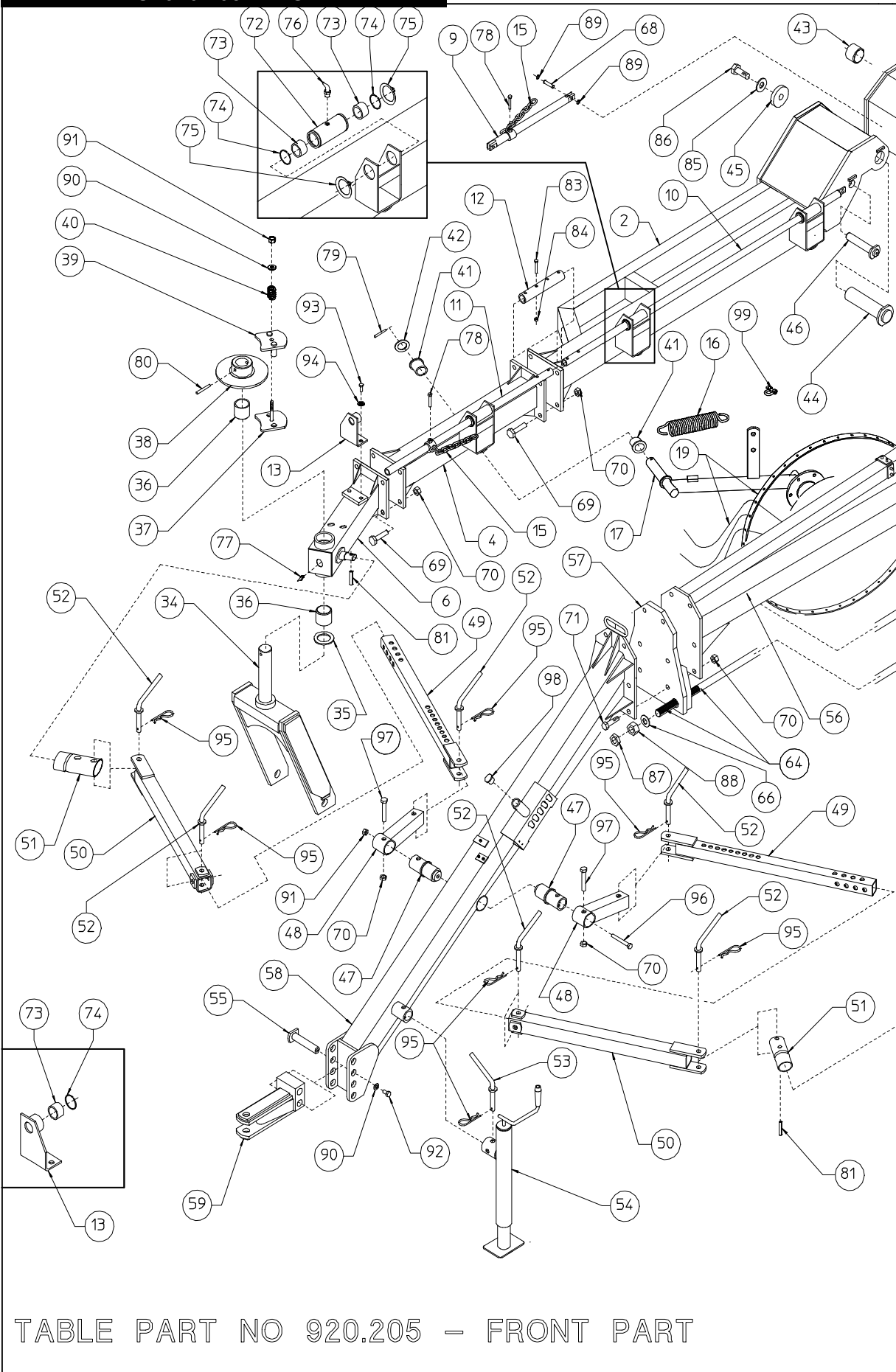

TABLE NO. 920.205 FRONT PART

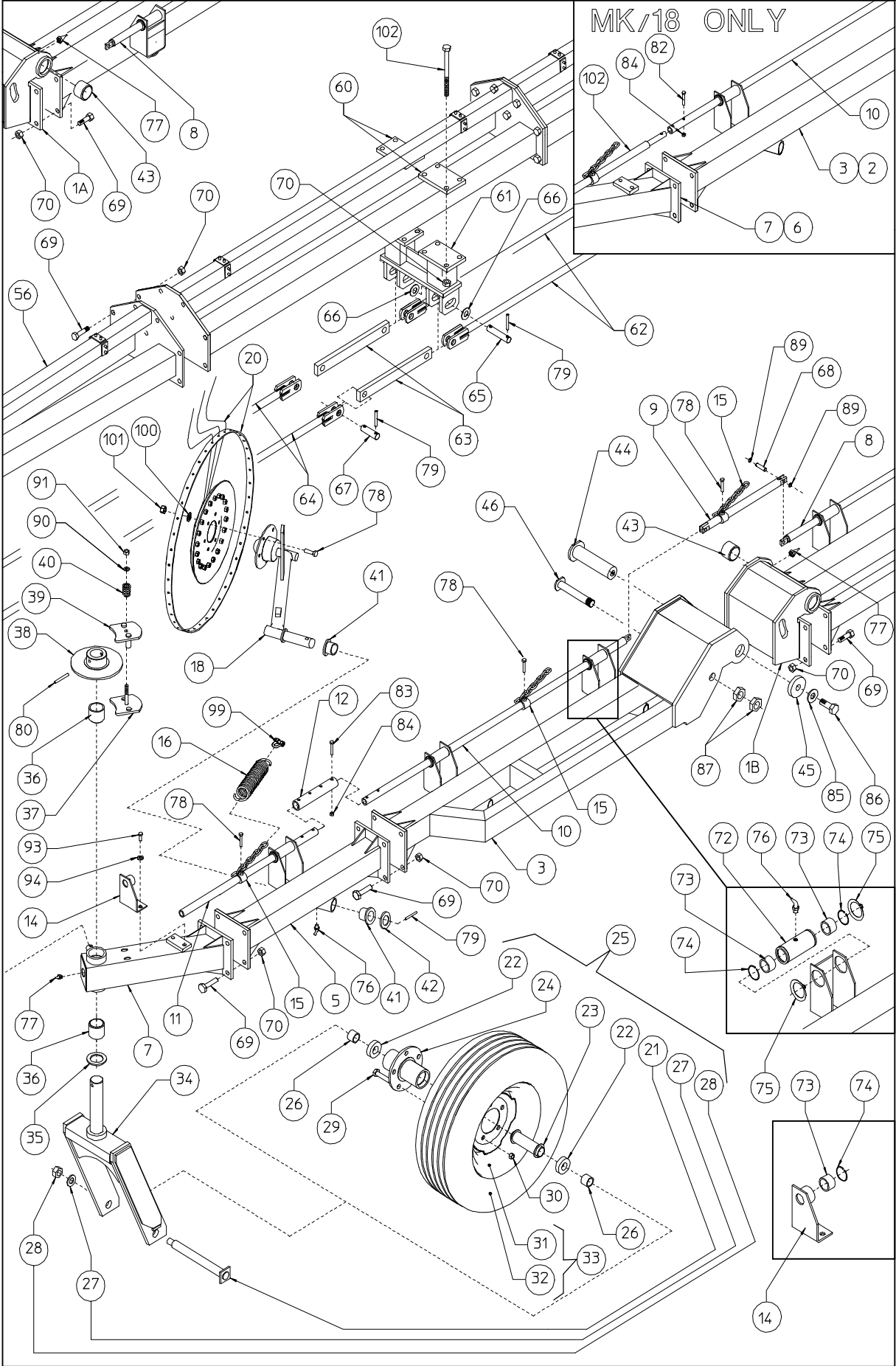

TABLE PART NO 920.205 - FRONT PART					
ITEM	MK/18 Q.ty	MK/20 Q.ty	PART NO	DESCRIPTION	NOTE
1A	1	1	230.081	SUPPORT	RH
1B	1	1	230.082	SUPPORT	LH
2	1	1	230.075	SECTION 2 RH WHEEL	
3	1	1	230.076	SECTION 2 LH WHEEL	
4	*	1	220.372	SECTION 1 RH WHEEL	MK/20
5	*	1	220.373	SECTION 1 LH WHEEL	MK/20
6	1	1	210.837	RH SUPPORT	
7	1	1	210.838	LH SUPPORT	
8	2	2	220.845	PIPE	
9	2	2	220.844	TIE ROD	
10	2	2	220.846	PIPE	
11	*	2	220.353	FRONT PIPE	MK/20
12	*	2	220.357	BUSH	MK/20
13	1	1	220.360	RH SUPPORT	
14	1	1	220.361	LH SUPPORT	
15	4	6	220.356	CHAIN BUSH	
16	4	6	200.046	SPRING	
17	2	3	200.008	RH ARM	
18	2	3	200.803	LH ARM	
19	2	3	210.180	RH FINGER WHEEL, ASSY	
20	2	3	210.181	LH FINGER WHEEL, ASSY	
21	2	2	210.184	PIN	
22	4	4	600.609	BEARING (6206 2RS)	
23	2	2	200.140	SPACER	
24	2	2	200.139	HUB	
25	2	2	210.169	HUB, ASSY	
26	4	4	210.170	SPACER	
27	2	2	200.165	WASHER	
28	2	2	600.079	NUT (M22 DIN 980)	
29	10	10	600.144	SCREW (M16x1,5x40 DIN 961)	
30	10	10	600.289	SPECIAL NUT M16x1,5	
31	2	2	600.304	RIM	
32	2	2	600.303	TIRE	
33	2	2	600.281	WHEEL ASSY (205/75-R15)	
34	2	2	230.080	SUPPORT	
35	2	2	210.179	SHIM	
36	4	4	200.199	BUSH	
37	2	2	210.931	BRAKE COUNTER PLATE	
38	2	2	200.025	FLANGE	
39	2	2	200.810	BRAKE	
40	2	2	200.044	SPRING	
41	8	12	200.029	BUSH	
42	4	6	200.028	WASHER	
43	4	4	200.199	BUSH	
44	2	2	230.078	PIN	
45	2	2	200.822	SHIM	
46	2	2	230.079	PIN	
47	2	2	200.818	BUSH	
48	2	*	220.397	EXTENSION	MK/18
49	2	2	200.817	INNER ARM	
50	2	2	200.816	OUTER ARM	
51	2	2	220.204	BUSH	
52	6	6	200.820	PIN	

TABLE PART NO 920.205 - FRONT PART					
ITEM	MK/18 Q.ty	MK/20 Q.ty	PART NO	DESCRIPTION	NOTE
53	1	1	200.222	PIN	
54	1	1	220.166	PARKING STAND	
55	2	2	200.828	PIN	
56	1	1	210.095	DRAWBAR	
57	1	1	220.854	SUPPORT	
58	1	1	210.243	FRONT DRAWBAR	
59	1	1	210.306	TRACTOR HITCH	
60	2	2	220.853	COUNTER PLATE	
61	1	1	220.852	SUPPORT	
62	2	2	220.856	CENTER TIE ROD	
63	2	2	220.858	TIE ROD	
64	2	2	220.857	FRONT TIE ROD	
65	2	2	220.860	PIN	
66	6	6	220.208	WASHER	
67	2	2	220.859	PIN	
68	4	4	200.074	PIN	
69	25	33	610.167	SCREW (M16x45 DIN 933)	
70	41	49	600.080	NUT (M16 DIN 980)	
71	6	6	620.254	SCREW (M16x65 DIN 931)	
72	4	6	220.343	STEEL BUSH	
73	10	14	220.342	NYLON BUSH	
74	10	14	610.898	ELASTIC RIM (SB 44)	
75	8	12	610.833	SNAP RING (E 50)	
76	8	12	600.968	GREASE NIPPLE (M6x45°)	
77	4	4	600.034	GREASE NIPPLE (M8)	
78	28	42	600.006	SCREW (M10x25 DIN 933)	
79	12	14	600.027	SPRING PIN (ø8x50 DIN 1481)	
80	2	2	600.033	SPRING PIN (ø10x80 DIN 1481)	
81	2	2	610.809	SPRING PIN (ø10x32 DIN 1481)	
82	2	*	600.551	SCREW (M8x45 DIN 931)	MK/18
83	*	8	610.525	SCREW (M8x60 DIN 931)	MK/20
84	2	8	600.076	NUT (M8 DIN 980)	
85	2	2	600.214	SPRING WASHER (ø23 DIN 127B)	
86	2	2	600.150	SCREW (M22x50 DIN 933)	
87	6	6	610.813	NUT (M30 DIN 936)	
88	2	2	620.253	NUT (M30 DIN 934)	
89	8	8	600.023	SNAP RING (E 15)	
90	4	4	600.092	WASHER (ø13/36x2,5)	
91	3	3	600.077	NUT (M12 DIN 980)	
92	2	2	600.770	SCREW (M12x20 DIN 933)	
93	4	4	610.843	SCREW (M10x16 DIN 933)	
94	4	4	600.322	WASHER (ø10,5 DIN 433)	
95	7	7	600.019	SPLIT PIN (ø3)	
96	1	1	600.618	SCREW (M12x60 DIN 931)	
97	2	*	610.187	SCREW (M16x80 DIN 933)	MK/18
98	1	1	610.790	PLUG	
99	4	6	610.317	"D" SACKLES	
100	24	36	600.024	SPRING WASHER (ø10,5 DIN 127B)	
101	24	36	600.010	NUT (M10 DIN 934)	
102	8	8	600.219	SCREW (M16x150 DIN 933)	
103	2	*	220.355	FRONT PIPE	MK/18

TABLE NO. 920.142 HYDRAULIC KIT

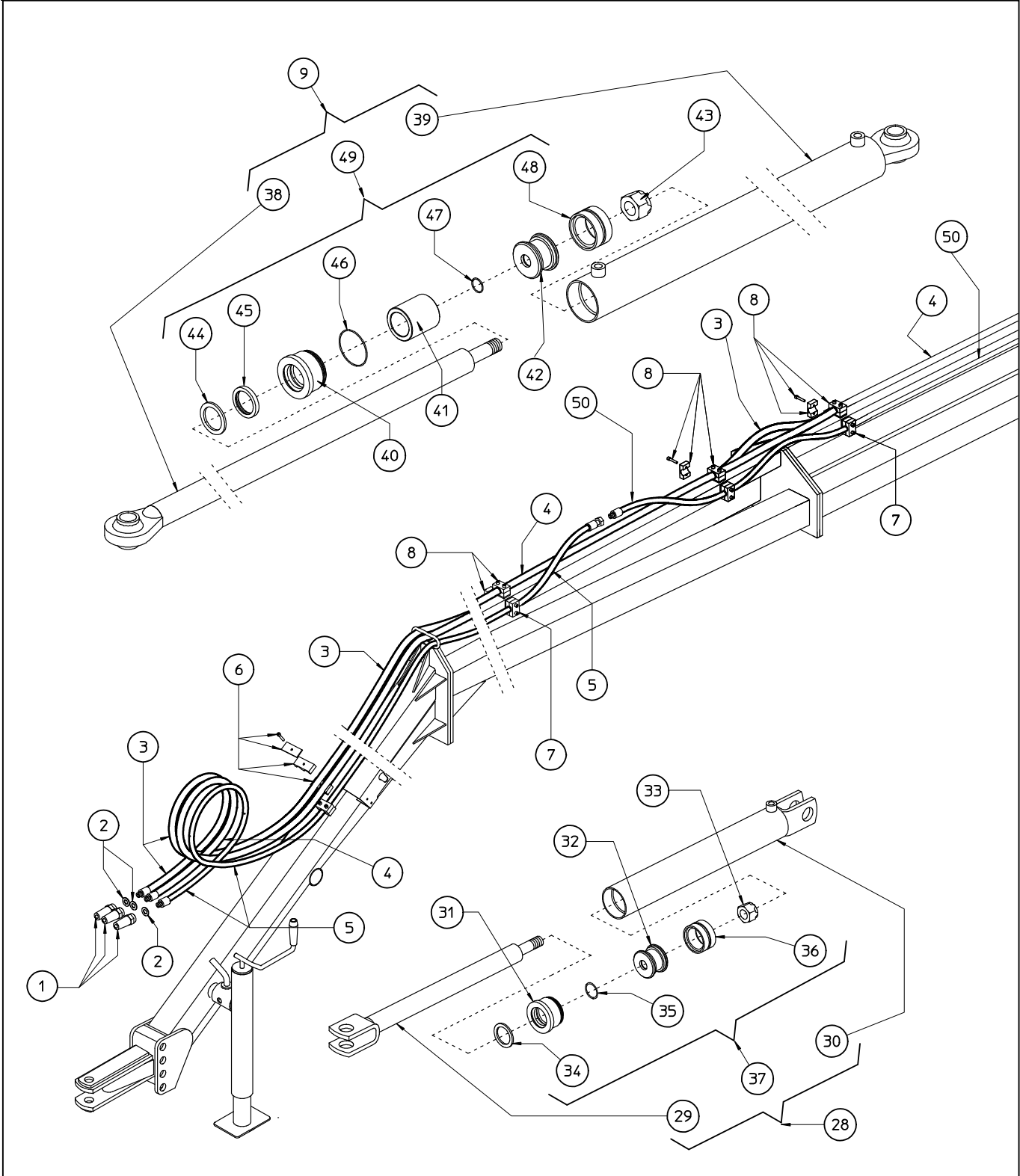

TABLE NO. 920.142 HYDRAULIC KIT

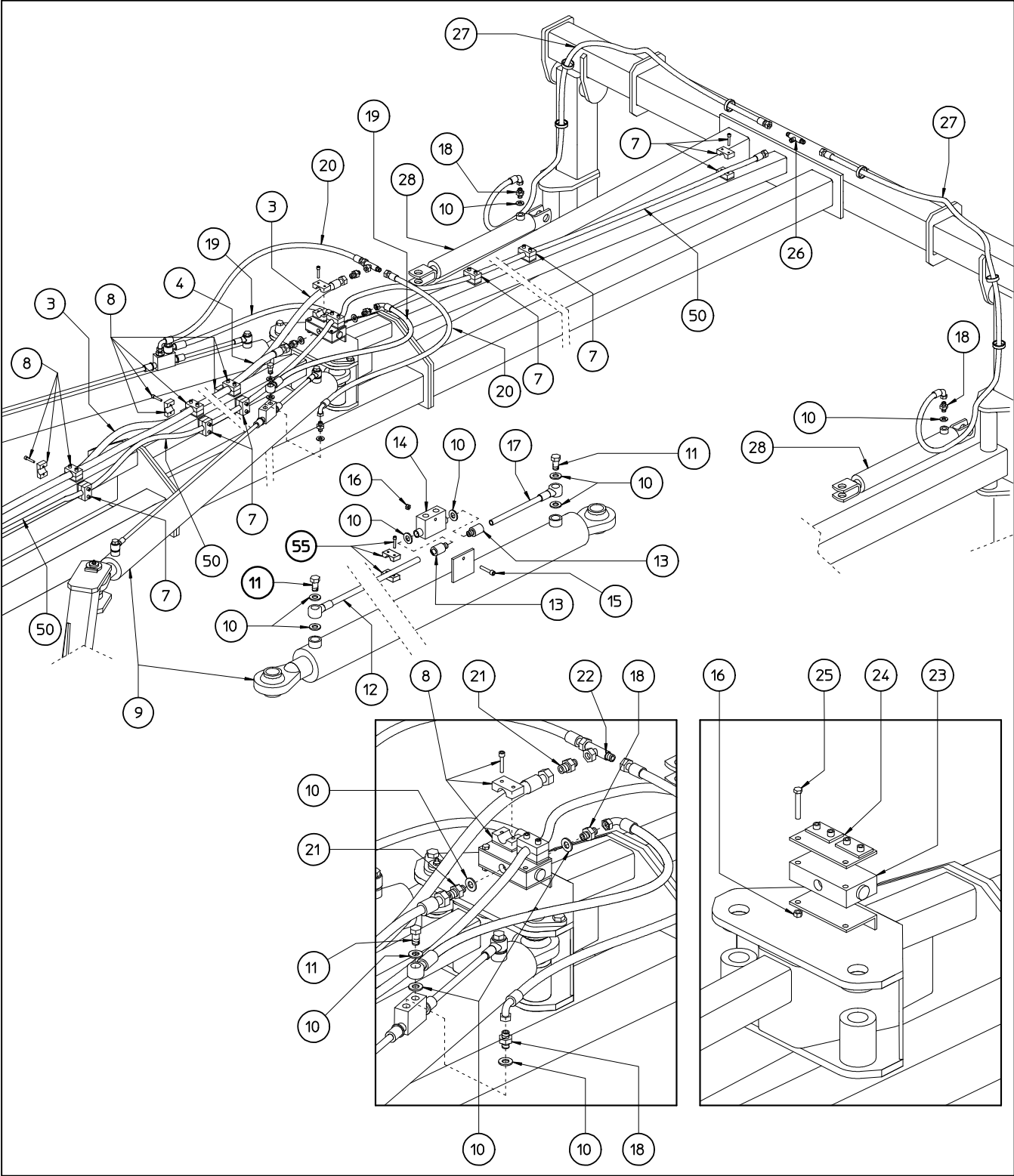

TABLE NO 920.142 HYDRAULIC KIT					
ITEM	Q.ty MK18	Q.ty MK20	PART NO	DESCRIPTION	NOTE
1	3	3	600.273	RAPID COUPLING 1/2"	
2	3	3	600.269	COPPER WASHER 1/2"	
3	1	1	610.825	HOSE SAE100 R2AT 1/2" FP 1/2 - MP 1/2"	
4	1	1	610.824	HOSE SAE100 R2AT 1/2" FP 1/2 - MP 1/2"	
5	1	1	610.728	HOSE SAE100 R2AT 3/8 MP 1/2" - FP 3/8"	
6	1	1	600.978	DOUBLE HOSE COLLAR	
7	10	10	600.822	HOSE COLLAR	
8	11	11	600.971	HOSE COLLAR	
9	2	2	210.215	CYLINDER	
10	23	23	600.039	COPPER WASHER 3/8"	
11	6	6	600.040	FITTING D 3/8"	
12	2	2	210.240	IRON PIPE	
13	4	4	610.469	FITTING	
14	2	2	600.799	LOCK VALVE VSD 3/8"	
15	2	2	600.869	SCREW M 6 X 40 DIN 931 8.8	
16	5	5	600.472	NUT M 6 DIN 980	
17	2	2	210.194	IRON PIPE	
18	6	6	600.270	NIPPLE 3/8" - 3/8"	
19	2	2	610.729	HOSE SAE100 R2AT 3/8 O 3/8" - FP90 3/8"	
20	2	2	610.730	HOSE SAE100 R2AT 3/8 FP90 3/8" - FP 3/8"	
21	2	2	600.416	NIPPLE 3/8" - 1/2"	
22	1	1	600.977	FITTING MM-FG 3/8"	
23	1	1	600.974	FLOW DIVIDER	
24	1	1	210.188	PLATE	
25	2	2	600.970	SCREW M 6 X 60 DIN 931 8.8	
26	1	1	600.272	FITTING MM-M 3/8"	
27	2	2	610.731	HOSE SAE100 R2AT 3/8 FP 3/8" - FP90 3/8"	
28	2	2	210.816	CYLINDER	
29	2	2	210.221	ROD	
30	2	2	210.222	CYLINDER PIPE	

TABLE NO 920.142 HYDRAULIC KIT					
ITEM	Q.ty MK18	Q.ty MK20	PART NO	DESCRIPTION	NOTE
31	2	2	200.302	HEAD	
32	2	2	200.304	PISTON	
33	2	2	600.642	NUT M18 X1,5 DIN 982 - 8	
34	2	2	600.645	GASKET WRM 118149 (D 30)	
35	2	2	600.646	GASKET OR 117 (D 20,29 X 2,62)	
36	2	2	600.648	GASKET DBM 196133 BORE 50	
37	2	2	600.644	KIT GASKET	
38	2	2	220.430	ROD	
39	2	2	220.429	CYLINDER PIPE	
40	2	2	220.432	HEAD	
41	2	2	220.431	SPACER	
42	2	2	220.433	PISTON	
43	2	2	610.928	NUT M30 X 2 DIN 985 - 8	
44	2	2	610.006	GASKET WRM 196228 (D 50)	
45	2	2	610.007	GASKET B 236196 (D 50)	
46	2	2	610.929	GASKET OR 845 + PBK (D 73,03 X 3,53)	
47	2	2	610.927	GASKET OR 123 (D 29,82 X 2,62)	
48	2	2	610.010	GASKET DBM 314236 BORE 80	
49	2	2	610.926	KIT GASKET	
50	1	1	610.826	HOSE SAE100 R2AT 3/8 MP 3/8" - FP 3/8"	
55	2	2	610.421	HOSE COLLAR	

TABLE NO. 920.152 HYDRAULIC REAR OPENING KIT (OPTIONAL)

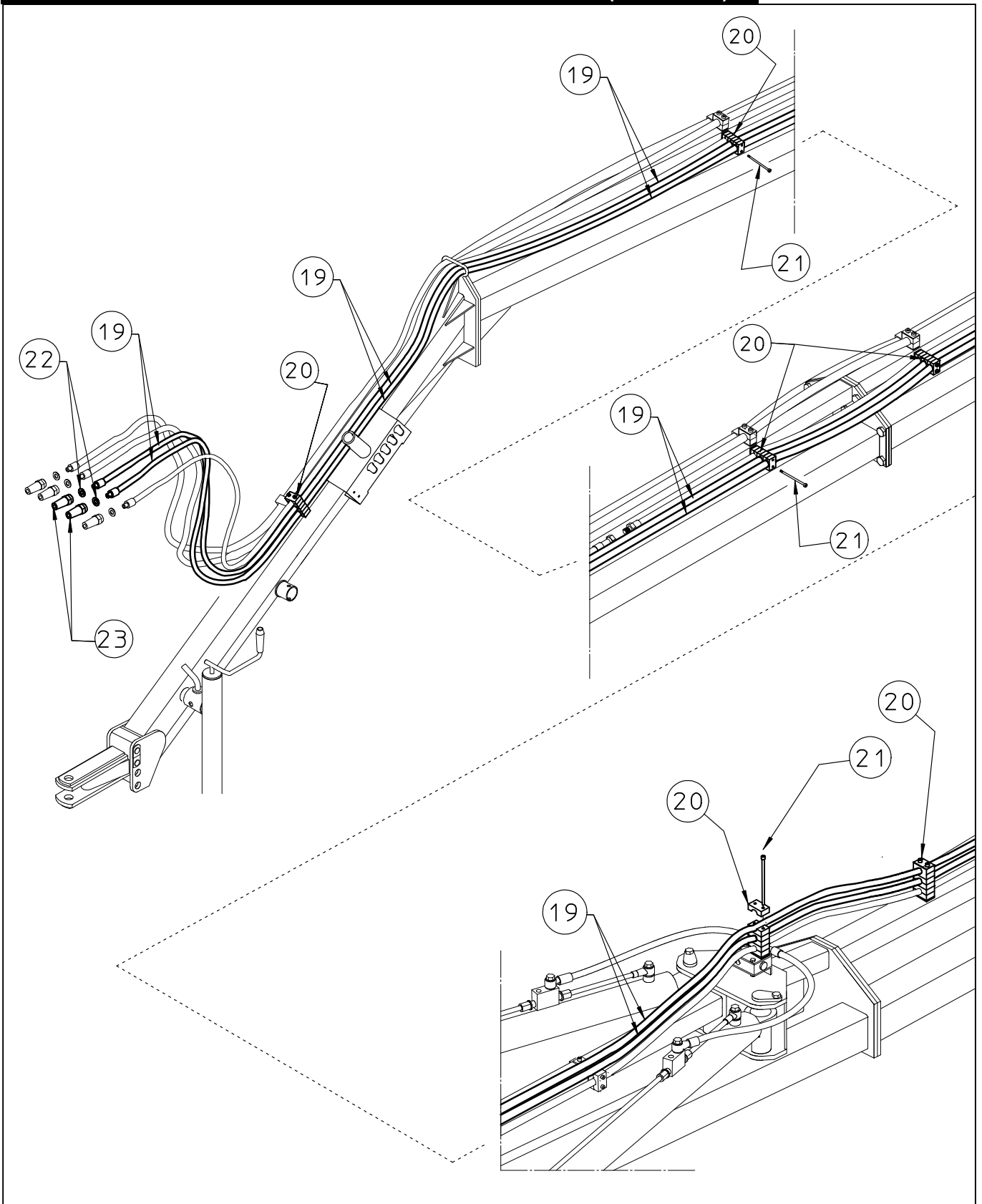

TABLE NO. 920.152 HYDRAULIC REAR OPENING KIT (OPTIONAL)

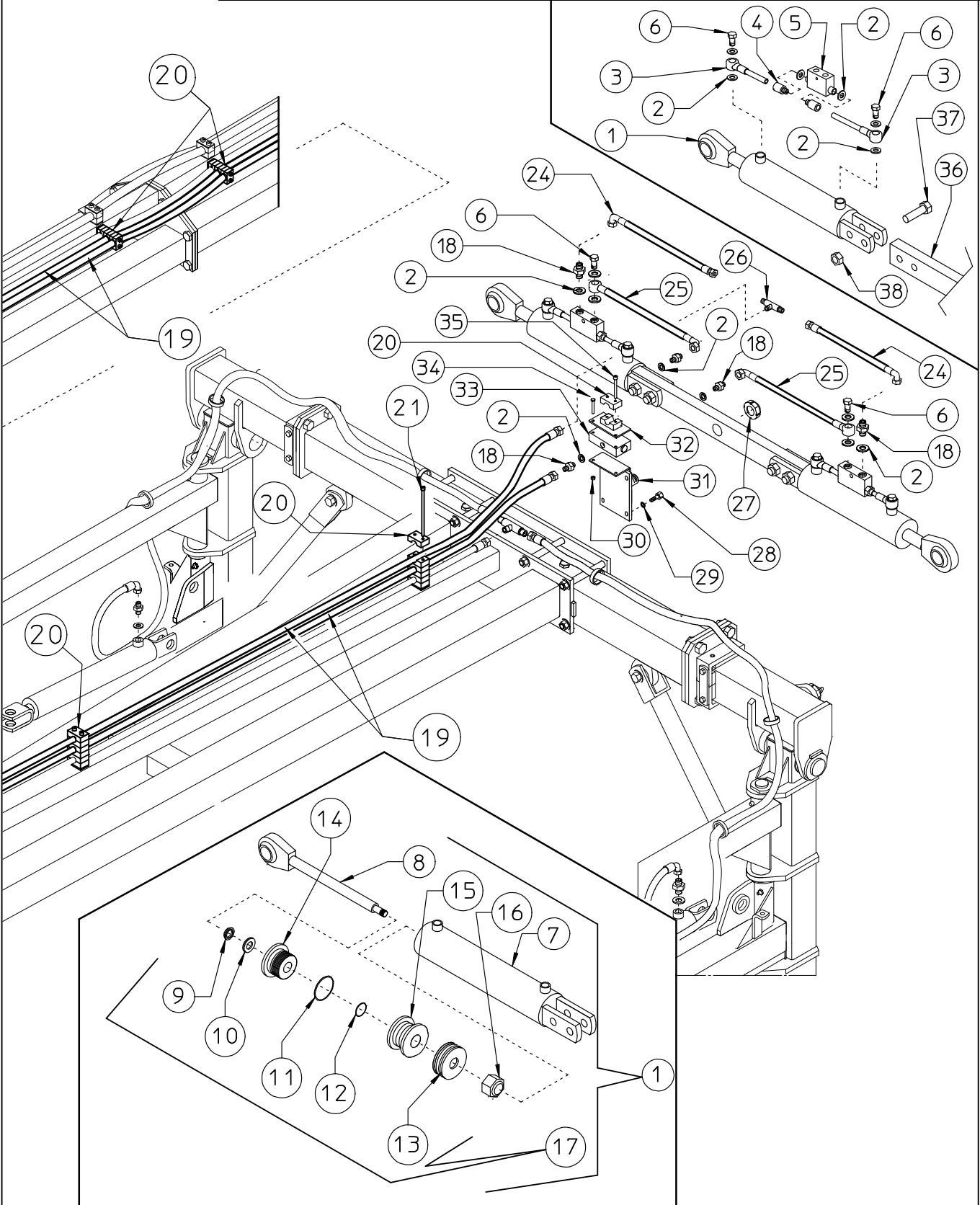
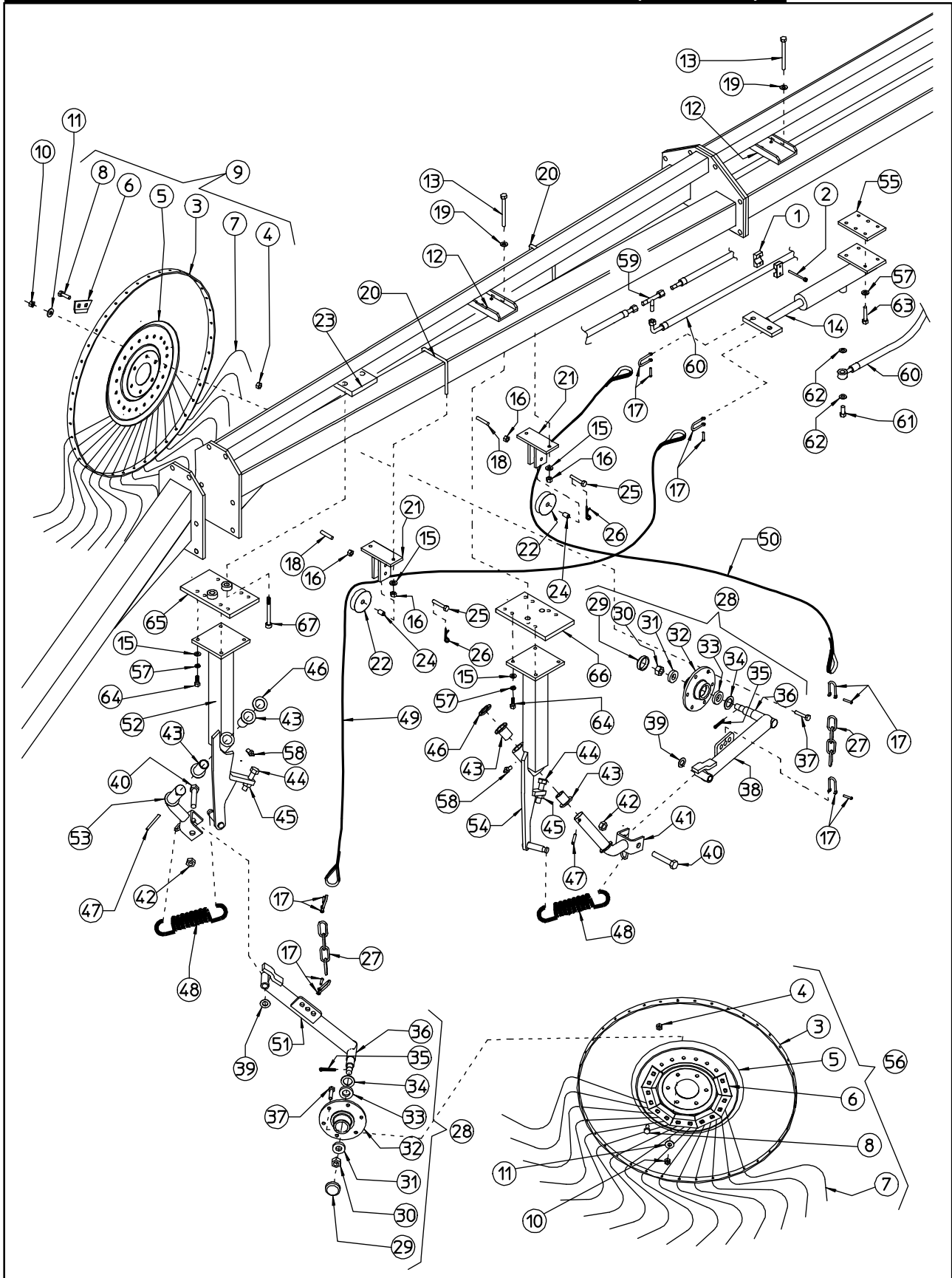

TABLE NO 920.152 HYDRAULIC REAR OPENING KIT (OPTIONAL)					
ITEM	Q.ty MK18	Q.ty MK20	PART NO	DESCRIPTION	NOTE
1	2	2	220.227	CYLINDER	
2	21	21	600.039	COPPER WASHER D 3/8"	*
3	4	4	610.511	IRON PIPE	*
4	4	4	610.469	FITTING	*
5	2	2	600.799	LOCK VALVE VSD 3/8"	*
6	6	6	600.040	FITTING D 3/8"	*
7	2	2	220.226	CYLINDER BARREL	
8	2	2	220.225	ROD	
9	2	2	600.645	GASKET WRM 118149 D 50	
10	2	2	610.031	GASKET B 157118 D 30	
11	2	2	600.875	GASKET OR 832 D 52,39 X 3,53	
12	2	2	600.646	GASKET OR117 D 20,29 X 2,62	
13	2	2	600.647	GASKET DBM 236173 BORE 60	
14	2	2	200.301	CYLINDER HEAD	
15	2	2	200.303	PISTON	
16	2	2	610.087	LOCK-NUT M20 X1.5 DIN 982 - 8	
17	2	2	610.030	SET OF GASKETS	
18	5	5	600.270	NIPPLE M 3/8"-M 3/8"	*
19	2	2	610.828	HOSE SAE100 R2AT 3/8 MP 1/2" - FP 3/8"	* MK 10/12
19	2	2	610.697	HOSE SAE100 R2AT 3/8 MP 1/2" - FP 3/8"	* MK 14/16
19	2	2	610.830	HOSE SAE100 R2AT 3/8 MP 1/2" - FP 3/8"	* MK 18/20
20	26	26	610.035	HALF HOSE COLLAR	
21	14	14	610.956	SCREW M6 X 95	
22	2	2	600.269	COPPER WASHER D 1/2"	*

TABLE NO 920.152 HYDRAULIC REAR OPENING KIT (OPTIONAL)					
ITEM	Q.ty MK18	Q.ty MK20	PART NO	DESCRIPTION	NOTE
23	2	2	600,273	RAPID COUPLING D 1/2"	*
24	2	2	610,778	HOSE SAE100 R2AT 3/8 FP 3/8" - F9P 3/8"	*
25	2	2	610,699	HOSE SAE100 R2AT 3/8 FP90 3/8" - O 3/8"	*
26	1	1	600,272	FITTING MM-M 3/8"	*
27	1	1	610,593	LOCK-NUT M30 X 1,5	
28	4	4	600,702	SCREW M8 X 25 DIN 933 8.8	
29	4	4	600,115	WASHER D 8,4 DIN 7972	
30	2	2	600,472	NUT M6 DIN 980	
31	1	1	220,259	CYLINDER SUPPORT	
32	1	1	220,283	HOSE SUPPORT	
33	1	1	600,974	FLOW DIVIDER	
34	2	2	600,970	SCREW M6 X 60 DIN 931 8.8	
35	2	2	610,037	SCREW M6 X 25 DIN 912 8.8	
36	1	1	215,979	CYLINDER ROD	
37	4	4	600,292	SCREW M16 X 70 DIN 933 8.8	
38	4	4	600,080	NUT M16 DIN 980	
*	1	1	220,248	HYDRAULIC KIT	MK 10/12
*	-	-	220,281	HYDRAULIC KIT	MK 14/16
*	-	-	220,250	HYDRAULIC KIT	MK 18/20
-	1	1	220,171	HYDRAULIC REAR OPENING KIT	MK 10/12
-	-	-	220,263	HYDRAULIC REAR OPENING KIT	MK 14/16
-	-	-	220,173	HYDRAULIC REAR OPENING KIT	MK 18/20

PART NO. 220.344 HYDRAULIC CENTRAL WHEELS KIT (OPTIONAL)



HYDRAULIC-CENTRAL WHEELS KIT (OPTIONAL)

HYDRAULIC CENTRAL WHEELS KIT PART NO. 220.344 (OPTIONAL)				
ITEM	Q.ty	PART NO.	DESCRIPTION	NOTE
1	4	610.035	HALF HOSE COLLAR 3/8"	
2	4	610.906	SCREW M6 X 130 8.8	MK hydraulic rear opening
2	4	610.901	SCREW M6 X 60 DIN 912 8.8	MK standard rear opening
3	2	200.840	RIM	
4	40	600.029	NUT M10 DIN 980	
5	2	200.010	FLANGE	
6	20	200.012	TINE LOCK	
7	80	200.841	TINE	
8	40	600.005	SCREW M10 X 25 DIN 603 6.8	
9	1	200.802	WHEEL ASSY L.H.	RH SIDE
10	12	600.010	NUT M10 DIN 934 - 8	
11	12	600.024	SPRING WASHER D 10.5	
12	2	220.347	COUNTER PLATE	
13	4	600.392	SCREW M16 X 120 DIN 931 8.8	
14	1	210.567	LIFT CYLINDER	
15	12	600.089	WASHER D 13 DIN 125A	
16	6	600.077	NUT M12 DIN 980	
17	6	610.317	FORK ASSY	
18	2	600.539	SPRING PIN D 6 X 45 DIN 1481	
19	4	600.180	SPRING WASHER	
20	2	210.582	U BOLT	
21	2	210.564	PULLEY BRACKET	
22	2	200.741	PULLEY	
23	1	220.507	COUNTERPLATE	
24	2	210.581	BUSH	
25	2	210.627	SCREW	
26	2	600.019	SPLIT PIN	
27	2	210.657	CHAIN	
28	2	205.777	HUB ASSY	
29	2	600.016	CAP	
30	2	600.015	CASTLE NUT M18 X 1,5 - 6	
31	2	600.014	BEARING 30204	
32	2	205.291	HUB	
33	2	600.012	BEARING 30205	
34	2	600.011	DUST COVER	
35	2	600.301	SPLIT PIN D 3 X 30 DIN 94 3.6	
36	2	205.819	PIN	
37	12	600.006	SCREW M10 X 25 DIN 933 8.8	
38	1	210.566	ARM	
39	2	600.756	WASHER D 19 DIN 433	
40	2	600.266	SCREW M18 X 100 DIN 931 8.8	
41	1	210.617	BRACKET	
42	2	600.078	NUT M18 DIN 980	
43	4	200.029	BUSH	
44	2	600.564	SCREW M12 X 60 DIN 933 8.8	
45	2	600.052	NUT M12 DIN 934 - 8	
46	2	200.028	WASHER	
47	2	600.027	SPRING PIN D 8 X 50 DIN 1481	
48	2	210.610	SPRING	
49	1	220.348	STEEL CABLE	
50	1	220.383	STEEL CABLE	
51	1	210.563	ARM	
52	1	220.345	BRACKET	
53	1	210.616	BRACKET	
54	1	210.565	BRACKET	
55	1	220.346	PLATE	
56	1	200.801	WHEEL ASSY R.H.	LH SIDE
57	12	600.018	SPRING WASHER D 13	
58	2	600.968	GREASE NIPPLE M6 - 45°	
59	1	610.411	FITTING	*
60	1	610.899	CYLINDER HOSE	*
61	1	600.040	FITTING 3/8"	*
62	2	600.039	COPPER WASHER	*
63	4	610.962	SCREW M12 X 30 DIN 933 8.8	
64	8	600.441	SCREW M 12 X 25	
65	1	220.505	PLATE	
66	1	220.506	PLATE	
67	2	620.017	SCREW	
*	1	220.349	HYDRAULIC ASSY	

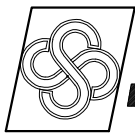

AGRICULTURAL MACHINERY
sitrex[®] Spa .

Zona Industriale-Viale Grecia, 8
06018 TRESTINA-(Perugia)-ITALY
Tel. +39.075.8540021-Telefax +39.075.8540523
e-mail: sitrex@sitrex.it www.sitrex.com

