

RHFA

Rear-Mounted Mechanical Sweeper



The Power of Combined Excellence



Serial Number _____

Manual Number: 51-4150
Release Date: August 1, 2008
Serial Number: 0832005 and Up

Contents

INTRODUCTION	5
SAFETY STATEMENTS	5
GENERAL SAFETY PRECAUTIONS.....	6-7
SAFETY SIGNS & LABELS	8
SERVICE & REPAIR - SAFETY	9
INSTALLATION	10-14
ADJUSTMENTS	15-16
OPERATION.....	17-18
STORAGE	18
MAINTENANCE	19-27
TROUBLESHOOTING	28-29
BRUSH HEAD	30-31
MOUNTING ASSEMBLY	32
DRIVE SHAFTS	33
GEARBOX.....	34
ANGLE KITS	35-36
OPTION - DIRT DEFLECTOR.....	37-38
OPTION - HOOD KITS	39-40
OPTION - SPRINKLER	41-44
TORQUE VALUES	45
GLOSSARY	46-47
WARRANTY INFORMATION	48

INTRODUCTION

Purpose of Sweeper

This sweeper is designed solely for the use in construction cleanup, road maintenance and similar operations. Use in any other way is considered contrary to the intended use. Compliance with and strict adherence to operation, service and repair conditions, as specified by the manufacturer, are also essential elements of the intended use.

Contacting Sweepster

If you have any questions about information in this manual or need to order parts, please call, write, fax or e-mail SWEEPSTER.

Sweepster
2800 North Zeeb Road
Dexter, Michigan 48130
Phone: (734)-996-9116 - (800)-456-7100
Fax: (734) 996-9014
e-mail: sweepster@paladinbrands.com

For help with installation, operation or maintenance procedures, contact our Technical Service Department. Direct product questions and parts orders to our Sales Department.

When ordering parts or accessories, be prepared to give the following information:

- Sweeper model, serial number and date of purchase
- Prime mover, make and model
- Part number, description and quantity

Terms Used in Manual

Right-hand, left-hand, front and rear are determined from the operator's perspective (either the operator's seat or standing behind a walk-behind unit), facing forward in the normal operating position.

Warranty

To validate the warranty for this unit, fill out the warranty card or warranty pages located in the back of this manual. Then send this information to SWEEPSTER.

SAFETY STATEMENTS



THIS SYMBOL BY ITSELF OR WITH A WARNING WORD THROUGHOUT THIS MANUAL IS USED TO CALL YOUR ATTENTION TO INSTRUCTIONS INVOLVING YOUR PERSONAL SAFETY OR THE SAFETY OF OTHERS. FAILURE TO FOLLOW THESE INSTRUCTIONS CAN RESULT IN INJURY OR DEATH.

DANGER



THIS SIGNAL WORD IS USED WHERE SERIOUS INJURY OR DEATH WILL RESULT IF THE INSTRUCTIONS ARE NOT FOLLOWED PROPERLY.

WARNING



THIS SIGNAL WORD IS USED WHERE SERIOUS INJURY OR DEATH COULD RESULT IF THE INSTRUCTIONS ARE NOT FOLLOWED PROPERLY.

CAUTION



THIS SIGNAL WORD IS USED WHERE MINOR INJURY COULD RESULT IF THE INSTRUCTIONS ARE NOT FOLLOWED PROPERLY.

NOTICE

NOTICE INDICATES A PROPERTY DAMAGE MESSAGE.

GENERAL SAFETY PRECAUTIONS

WARNING!



READ MANUAL PRIOR TO INSTALL

Improper installation, operation, or maintenance of this equipment could result in serious injury or death. Operators and maintenance personnel should read this manual as well as all manuals related to this equipment and the prime mover thoroughly before beginning installation, operation, or maintenance. **FOLLOW ALL SAFETY INSTRUCTIONS IN THIS MANUAL AND THE PRIME MOVERS MANUAL.**

WARNING!



READ AND UNDERSTAND ALL SAFETY STATEMENTS

Read all safety decals and safety statements in all manuals prior to operating or working on this equipment. Know and obey all OSHA regulations, local laws and other professional guidelines for your operation. Know and follow good work practices when assembling, maintaining, repairing, mounting, removing or operating this equipment.

KNOW YOUR EQUIPMENT

Know your equipment's capabilities, dimensions and operations before operating. Visually inspect your equipment before you start, and never operate equipment that is not in proper working order with all safety devices intact. Check all hardware to assure it is tight. Make certain that all locking pins, latches, and connection devices are properly installed and secured. Remove and replace any damaged, fatigued or excessively worn parts. Make certain all safety decals are in place and are legible. Keep decals clean, and replace them if they become worn and hard to read.

GENERAL SAFETY PRECAUTIONS

WARNING!



PROTECT AGAINST FLYING DEBRIS

Always wear proper safety glasses, goggles or a face shield when driving pins in or out or when operation causes dust, flying debris, or any other hazardous material.

WARNING!



LOWER OR SUPPORT RAISED EQUIPMENT

Do not work under raised booms without supporting them. Do not use support material made of concrete blocks, logs, buckets, barrels or any other material that could suddenly collapse or shift positions. Make sure support material is solid, not decayed, warped, twisted, or tapered. Lower booms to ground level or onto blocks. Lower booms and attachments to the ground before leaving the cab or operator's station.

WARNING!



USE CARE WITH HYDRAULIC FLUID PRESSURE

Hydraulic fluid under pressure can penetrate the skin and cause serious injury or death. Hydraulic leaks under pressure may not be visible. Before connecting or disconnecting hydraulic hoses, read your prime movers operator's manual for detailed instructions on connecting and disconnecting hydraulic hoses or fittings.

- Keep unprotected body parts, such as face, eyes, and arms as far away as possible from a suspected leak. Flesh injected with hydraulic fluid may develop gangrene or other permanent disabilities.
- If injured by injected fluid, see a doctor at once. If your doctor is not familiar with this type of injury, ask him to research immediately to determine proper treatment.

GENERAL SAFETY PRECAUTIONS

- Wear safety glasses, protective clothing, and use a sound piece of cardboard or wood when searching for hydraulic leaks.
DO NOT USE YOUR HANDS!
SEE ILLUSTRATION.

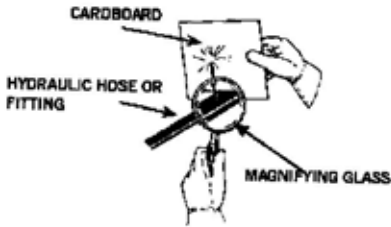

WARNING!



DO NOT MODIFY MACHINE OR ATTACHMENTS

Modifications may weaken the integrity of the attachment and may impair the function, safety, life and performance of the attachment. When making repairs, use only the manufacturer's genuine parts, following authorized instructions. Other parts may be substandard in fit and quality. Never modify any ROPS (Roll Over Protection System) equipment or device. Any modifications must be authorized in writing by the manufacturer.

WARNING!



SAFELY MAINTAIN AND REPAIR EQUIPMENT

- Do not wear loose clothing, or any accessories that can catch in moving parts. If you have long hair, cover or secure it so that it does not become entangled in the equipment.
- Work on a level surface in a well-lit area.
- Use properly grounded electrical outlets and tools.
- Use the correct tool for the job at hand. Make sure they are in good condition for the task required.
- Wear the protective clothing equipment specified by the tool manufacturer.

GENERAL SAFETY PRECAUTIONS

WARNING!



SAFELY OPERATE EQUIPMENT

Do not operate equipment until you are completely trained by a qualified operator in how to use the controls, know its capabilities, dimensions, and all safety requirements. See your prime movers manual for these instructions.

- Keep all step plates, grab bars, pedals, and controls free of dirt, grease, debris, and oil.
- Never allow anyone to be around the equipment when it is operating.
- Do not allow riders on the attachment or the prime mover.
- Do not operate the equipment from anywhere other than the correct operators position.
- Never leave equipment unattended with the engine running or with this attachment in a raise position.
- Do not alter or remove any safety feature from the prime mover or this attachment.
- Know your work site safety rules as well as traffic rules and flow. When in doubt on any safety issue, contact your supervisor or safety coordinator for an explanation.

SAFETY SIGNS & LABELS



1. 50-0726



2. 50-0721



3. 50-0634

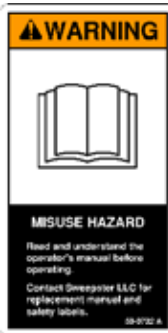

4. 50-0722



5. 50-0115

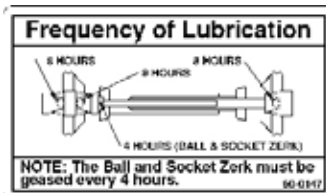
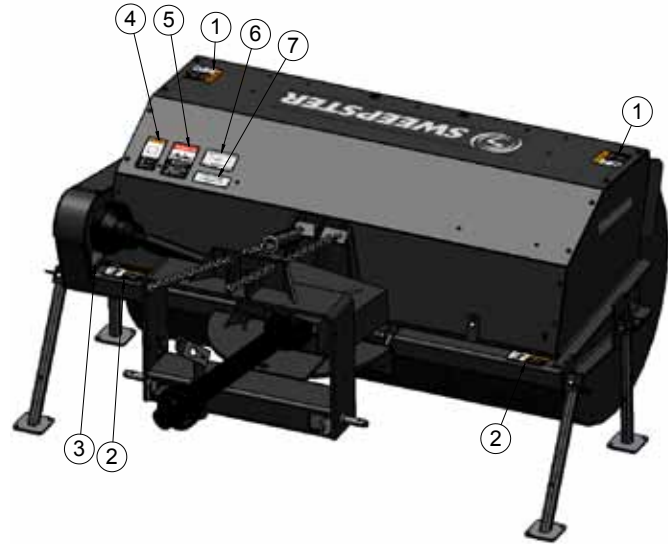

6. 50-0147



7. 50-0024

SAFETY SIGNS & LABELS

There are several specific signs on this sweeper. The exact location of the hazards and description of the hazards are reviewed.

Placement or replacement of Safety Signs

1. Clean the area of application with nonflammable solvent, and then wash the same area with soap and water.
2. Allow the surface to fully dry.
3. Remove the backing from the safety sign, exposing the adhesive surface.
4. Apply the safety sign to the position shown in the diagram above and smooth out any bubbles.

Item	Part	Qty	Description
1.	50-0726	2	Label, Warning, Flying Objects & Entanglement
2.	50-0721	2	Label, Warning, Crush Hazard
3.	50-0634	1	Label, Serial Number
4.	50-0722	1	Label, Warning, Misuse Hazard
5.	50-0115	1	Label, Danger, Rotating Driveline
6.	50-0147	1	Label, Frequent Lube
7.	50-0024	1	Label, Maximum Raise

Instructions

1. Keep all safety signs clean and legible.
2. Replace all missing, illegible, or damaged safety signs.
3. Replacement parts, for parts with safety signs attached, must also have safety signs attached.
4. Safety signs are available, free of charge, from your dealer or from SWEEPSTER.

SERVICE & REPAIR - SAFETY

CAUTION!



DO NOT MODIFY THE SWEEPER IN ANY WAY. Personal injury could result. If you have questions, contact your dealer or SWEEPSTER.

Do not bend high pressure lines. Do not strike high pressure lines. Do not install bent lines, bent tubes, or kinked hoses. Do not install damaged lines, tubes, or hoses.

Repair or adjust the sweeper in a safe area, away from traffic and other hazards.

Repair damaged or loose lines, tubes and hoses. Leaks can cause fires. See your SWEEPSTER dealer for repair or replacement parts.

Before adjusting or servicing the sweeper, lower the sweeper to the ground, stop the prime mover engine, set the brakes and remove the key from the ignition.

Replace the parts if any of the following conditions are present:

When working on or around the sweeper, lower it to the ground or secure it with transport chains or cylinder-stop locks.

- The end fittings are damaged or leaking.
- The outer covering is chafed or cut.
- The reinforcing wire layer is exposed.
- The outer covering is ballooning locally.
- The hose is kinked or crushed.
- The hose has been pulled or stretched.

Stop the prime mover engine and cycle control levers to release hydraulic pressure before servicing or adjusting sweeper hydraulic systems.

Make sure that all clamps, guards, and shields are installed correctly.

WARNING!



ESCAPING HYDRAULIC FLUID can have enough pressure to penetrate the skin, causing serious personal injury.

Installation Safety

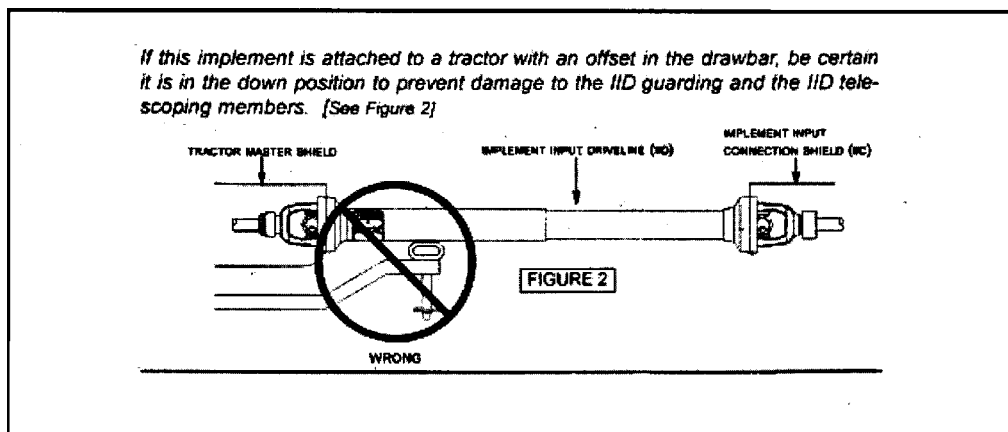
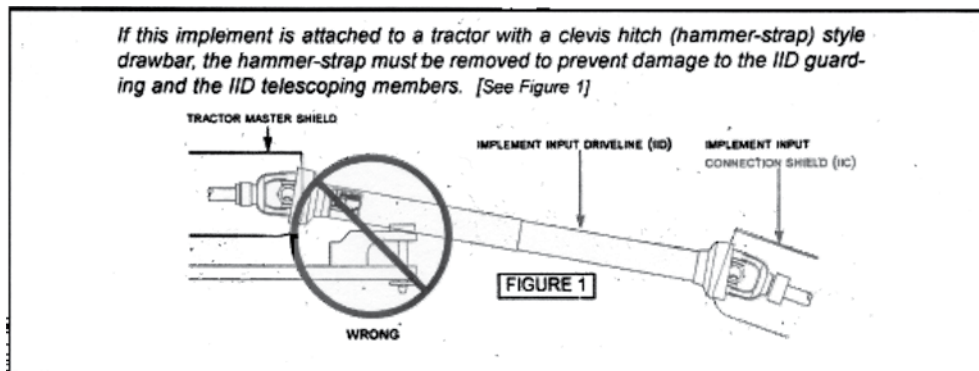

INSTALLATION

RHFA sweepers are designed to attach to SAE Category I or Category II 3-point hitches. To attach this sweeper to a Category II hitch, you must order Category II hitch pins.

This sweeper has been assembled so it sweeps while traveling forward. It can, however, sweep while moving in reverse. See Maintenance: Reverse Sweeping Direction to sweep while driving in reverse.

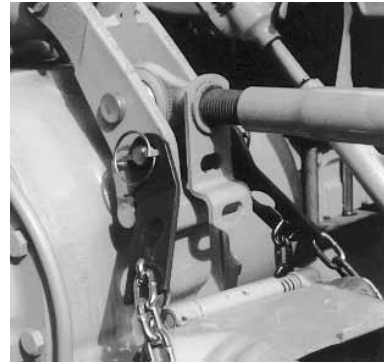

figure 1

INSTALLING SWEEPER

1. Attach hitch pins to the mounting frame. Place stop plates inside the mounting frame with bends to the center. Tighten hardware.
2. Attach a 39-link chain to each stop plate using a double clevis pin.
3. Pin 2 keyhole plates to the tractor toplink with pins from the tractor (figure 1).
4. Position the mounting assembly behind the tractor with the half-moon swing plate toward the rear.
5. Lower 3-point hitch arms completely.
6. Place the mounting assembly's pins in the hitch arms. Secure with ring pins (figure 2).
7. Connect the tractor toplink arm to the top of the mounting assembly (figure 3). Secure with a pin.

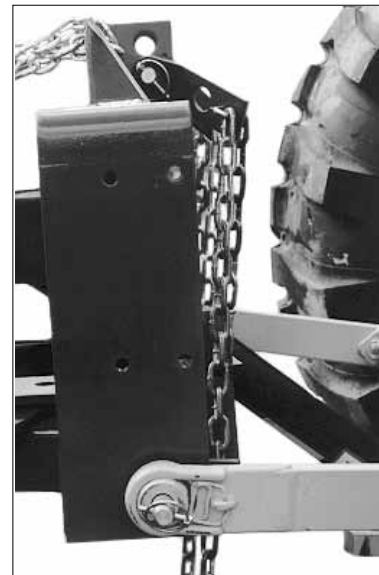

figure 2

NOTE: For a small-diameter toplink, use the pin provided with the sweeper and the top hole in the mounting frame ears. For large-diameter toplink, use the bottom hole and a customer-supplied pin.



figure 3

INSTALLATION

8. Adjust support chains, which are attached to the mounting assembly and keyhole plates.
 - a. Raise hitch arms until the center of the mounting assembly's rear plate is 16 inches (406mm) above the ground (figure 4).
 - b. Choose the link in each chain that will keep the mounting assembly at that measurement.
 - c. Raise hitch arms slightly.
 - d. Place links (chosen in step 8b) in keyhole slots.
 - e. Lower the mounting assembly until the center of the rear plate is 16 inches (406mm) above the ground.

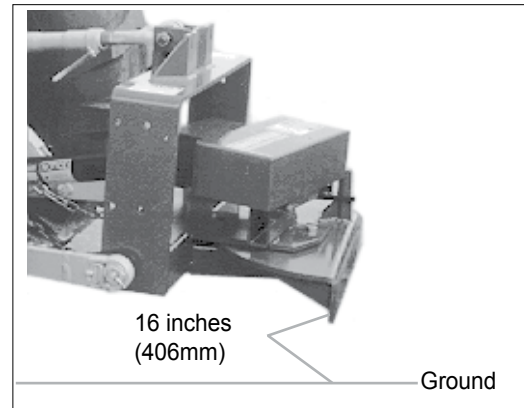

figure 4

NOTE: For wet, heavy and/or deep snow, adjust support chains so the mounting assembly remains 20-22 inches (508-559mm) off the ground when the unit is lowered.

CAUTION! AVOID EQUIPMENT DAMAGE.



Positioning the sweeper too close to the ground, less than 16 inches (406mm) can result in damage to the sweeper hood and gearbox. Keep the proper distance.

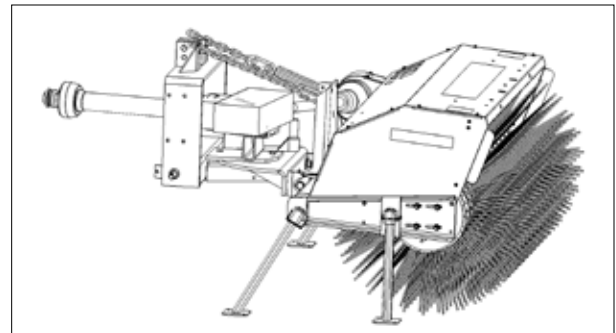

figure 5

9. Position the brush head assembly behind the mounting assembly (figure 5).
10. Align slots in the mounting assembly's rear plate and the brush head's frame plate. Secure with 3 carriage bolts, flat washers, lock washers and nuts. Figure 6 shows hardware fully installed.

NOTE: Make sure the top edges of the plates are parallel with each other. This becomes very important when adjusting the sweeper after installation.

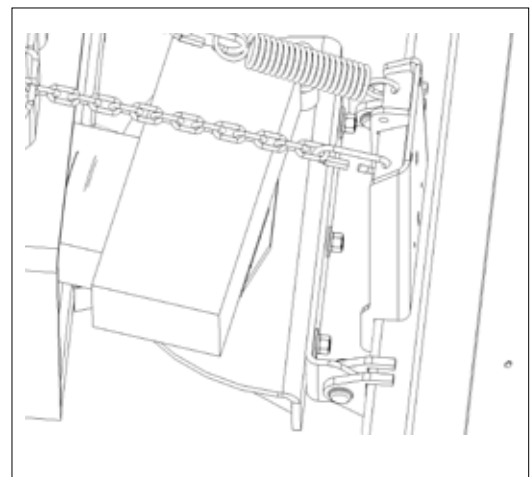

figure 6

INSTALLATION

11. Install the spring-chain assembly. Figure 1 shows the spring-chain assembly fully installed.

- a. Place a tension spring on 1 end of a 27-link chain, using a 5/16 wide jaw quick link.
- b. Attach the spring to the brush frame upright.
- c. Connect the chain to a slot in the chain holder on the mounting assembly.

12. Connect the transport chain, already attached to the brush frame upright, to the remaining slot in the chain holder on the mounting assembly. Figure 2 shows the transport chain fully installed.

13. Install the constant velocity (CV) shaft. Figure 3 shows the shaft fully installed.

- a. Connect the hex end of the CV shaft to the hex shaft on the brush head assembly.
- b. Attach the round end of the CV shaft to the gearbox output shaft.
- c. Tighten set screws and jam nuts.

14. Install the telescoping shaft. Figure 3 shows the shaft fully installed.

- a. Connect the round end of the telescoping shaft to the gearbox input shaft. Tighten the set screw and jam nut.
- b. Connect the 6-spline end of the telescoping shaft to the tractor PTO.

NOTE: It may be necessary to shorten the telescoping shaft. The shaft must slip freely as the brush head assembly is raised and lowered. Raise and lower the sweeper **slowly** to check that the telescoping shaft is the proper length.

CAUTION! **AVOID DRIVELINE DAMAGE.** Check the length of the telescoping members to insure the driveline will not bottom out or separate when turning and/or going over rough terrain.

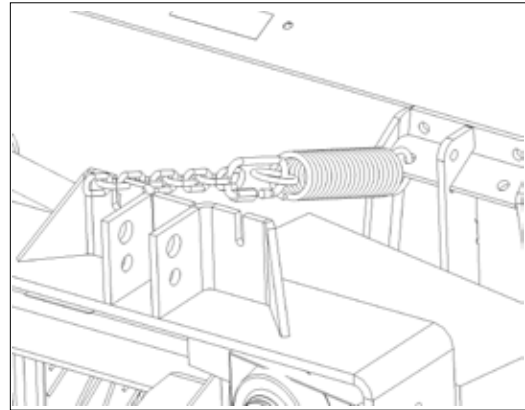

figure 1

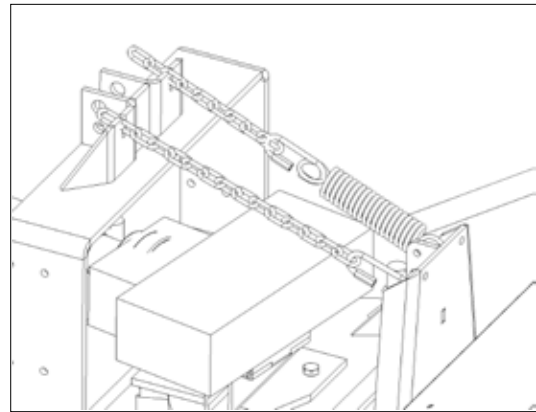

figure 2

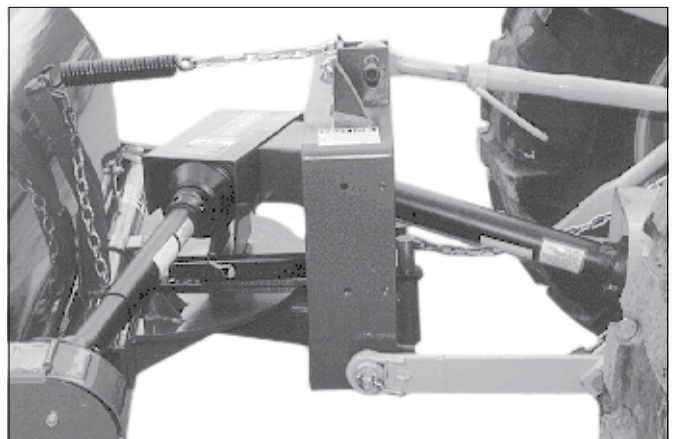

figure 3

INSTALLATION

15. Adjust the toplink so the swing frame is perpendicular to the ground.

16. Install the manual or hydraulic angle kit.

For manual angle, follow these instructions.

- a. Slide the tube with 1 hole into the other tube (figure 4)
- b. Place tubes on large pins welded to the mounting assembly (figure 5). The tube with one hole goes on the half-moon swing plate.
- c. Secure with 2 cotter pins (figure 5).
- d. Swing the sweeper to the desired angle. Make sure to align a set of holes in the tubes.
- e. Insert a lock pin in the aligned holes (figure 5).

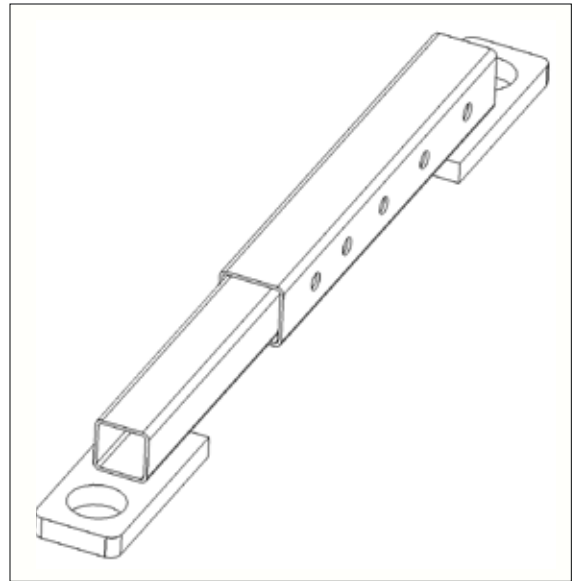

figure 4

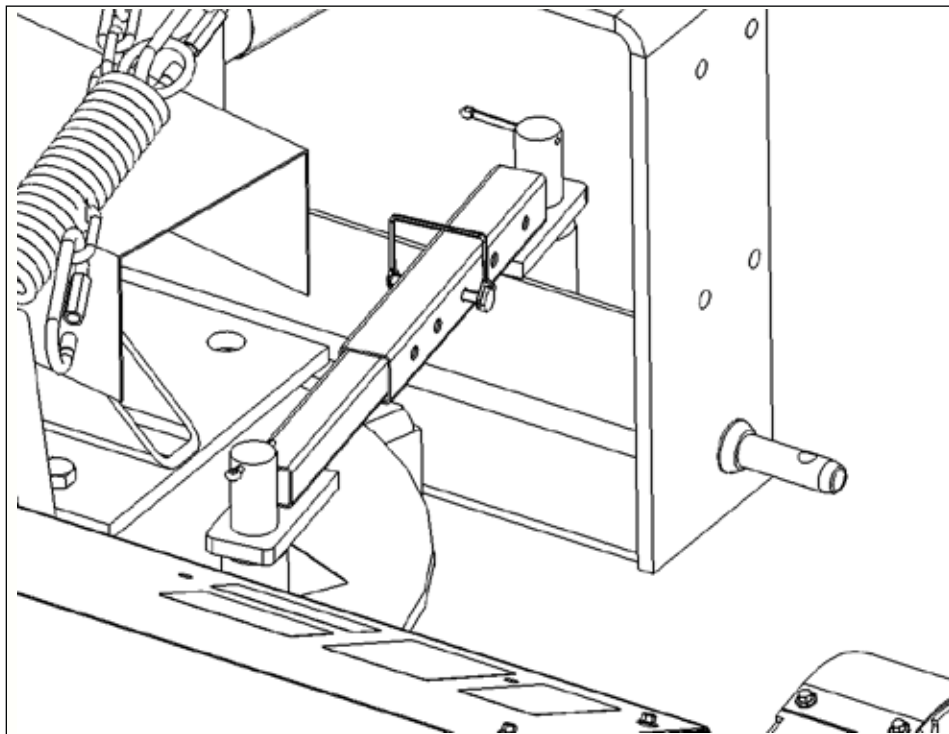

figure 5

INSTALLATION

For hydraulic angle, follow these instructions.

- a. Attach fittings to the cylinder with the elbow fitting on the rod end port and the orifice fitting on the barrel end port (figure 1).
- b. Install the cylinder with the barrel end on the mounting frame pin and the rod end on the swing plate pin. Secure with cotter pins (figure 2).
- c. Connect a hose to each fitting on the cylinder.
- d. Attach adapter fittings to the hose ends.
- e. Connect the adapter fittings to prime mover remote valves.

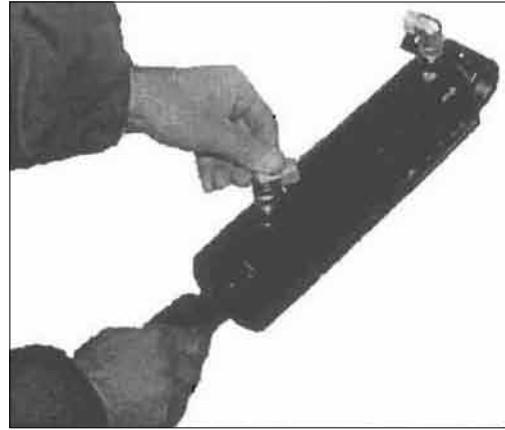

figure 1

NOTE: Additional hydraulic equipment, such as quick couplers and valves, that fit specific tractors is customer supplied.

17. Install storage stands. Figure 3 shows stands fully installed.
 - a. On one side of the brush head assembly, slide a straight stand into the tube near the bearing assembly. Align a hole in the stand with one in the tube. Secure with a lock pin.
 - b. Slide an angled stand into the tube toward the front of the brush frame. Align holes and secure with a lock pin.
 - c. Repeat steps 14a and 14b on the other side of the brush head assembly.

NOTE: Storage stands are designed to keep the brush off the ground when the sweeper is dismantled. When the sweeper is mounted, slide stands up in the tubes to keep them out of the way.

18. Install any other options. See the back of this manual for installation instructions.

19. Go to the Adjustments Section.



figure 2

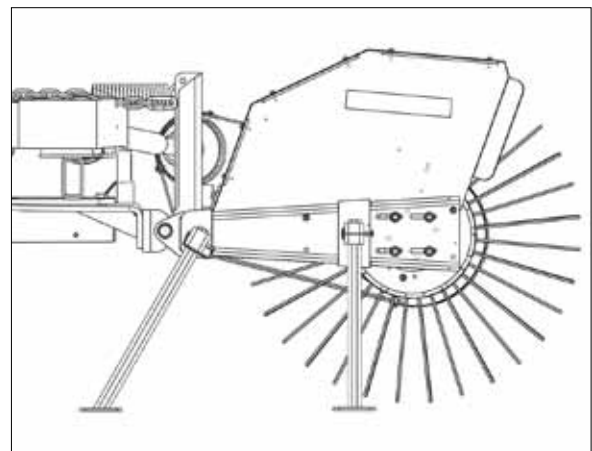

figure 3

ADJUSTMENTS

Leveling

For best performance, level the sweeper immediately after installation and as part of regular maintenance.

1. Move the unit to a dusty, paved surface.
2. Lower the brush head assembly so the bristle tips are 2 inches (51mm) off the ground.
3. Swing the brush head assembly straight ahead.
4. At each end of the brush head, measure from the center of the core shaft to the ground (figure 4).
 - If measurements are the same, go to step 5.
 - If measurements are not equal, make sure the top edges of the mounting assembly and brush head plates are parallel. Adjust, if necessary, and tighten the hardware. Then, lengthen or shorten the adjustable hitch arm to make measurements the same. Repeat step 4 until measurements are equal.
5. Swing the sweeper to the right. Take measurements as in step 4. Swing sweeper to the left and measure again.
 - If all measurements are equal, the sweeper is level.
 - If measurements are not equal, level the mounting assembly with the toplink. Follow instructions shown in figures 5 and 6; repeat until the sweeper is level.

NOTE: Make sure the telescoping shaft does not hit the mounting frame when the unit is raised. Reset lift limits if necessary.

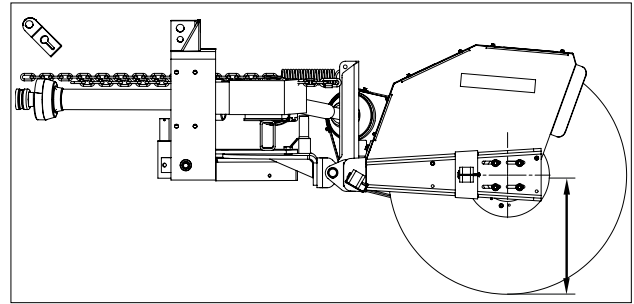

figure 4

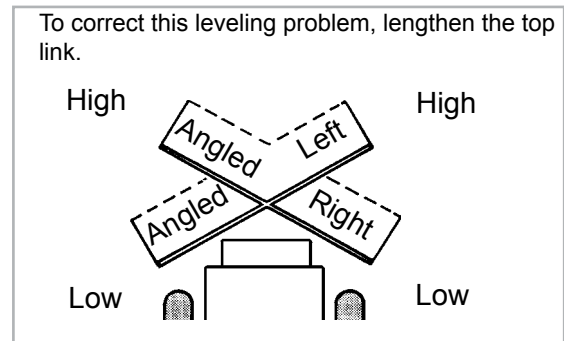

figure 5

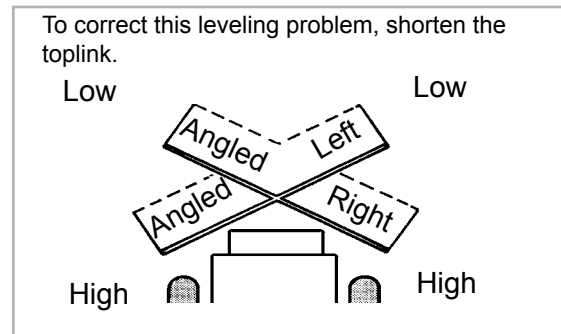

figure 6

ADJUSTMENTS

Adjusting Brush Pattern

A properly adjusted brush offers the best sweeper performance. To check the brush pattern:

1. Move the sweeper to a dusty, flat surface.
2. Set the prime mover's parking brake and leave the engine running.
3. Start the sweeper at a low speed; then, lower it completely to the surface so the bristle tips touch the ground. Run the sweeper in a stationary position for 30 seconds.
4. Raise the sweeper and back away; switch off the engine and remove the key. The brush pattern left in the dust should be 2-4 inches (51-76mm) wide, running the entire length of the brush. (compare the swept area with figure 1)

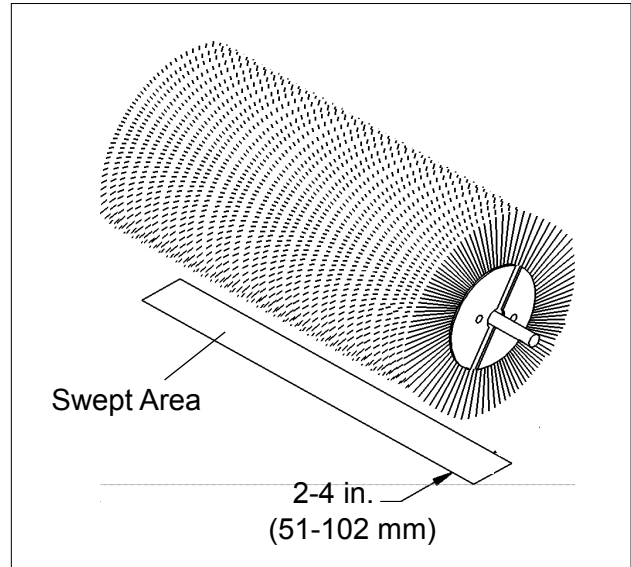

figure 1

Adjusting Spring-Chain Assembly

The spring-chain assembly sets the brush pattern by restricting up and down movement of the brush head assembly.

To adjust the brush pattern:

1. Raise the sweeper.
2. Increase or decrease the number of links in the spring-chain assembly between the mounting assembly chain holder and the brush head assembly chain holder.
 - Increase the number of links to lower the brush head assembly or
 - Decrease the number of links to raise the brush head assembly.
3. Adjust the transport chain.

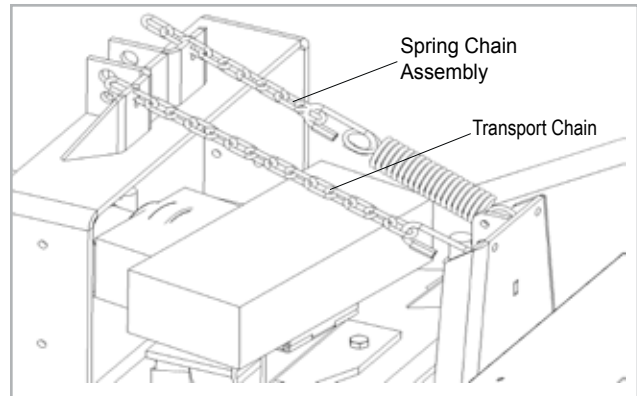

figure 2

Adjusting Transport Chain

The transport chain (figure 2) supports the weight of the brush head assembly during transport between work sites and during adjustment of the spring-chain assembly. When sweeping, the transport chain should have one or two links of slack.

To adjust the transport chain for moving between sites:

1. Lower the sweeper to the ground.
2. Pull the transport chain tight and secure it in the mounting assembly chain holder.
3. Raise the sweeper off the ground with the hitch lift. Most of the weight of the brush head assembly should be on the transport chain, not on the spring-chain assembly.

OPERATION

Sweeping

Model RHFA sweepers are powered from the rear PTO shaft at 540 rpm maximum.

To start the sweeper, engage the PTO at idle. To stop, disengage the PTO at idle.

This sweeper has been assembled so it sweeps while moving forward. It can, however, sweep while moving in reverse. See Maintenance: Reversing Sweeping Direction.

Raising & Lowering

To raise and lower the sweeper, use 3-point lift arms. Do not use a tip-and-tilt cylinder.

CAUTION! AVOID TIP-AND-TILT



CYLINDER AND SWEEPER

DAMAGE. Raise and lower the sweeper only with 3-point lift arms. Do not use a tip-and-tilt cylinder.

CAUTION! AVOID DRIVELINE DAMAGE.



Do not run brush in raised position. Only run the brush with the sweeper lowered.

Angling

Use the angle feature to control the direction debris exits the sweeper. Angling the brush head the same direction as the wind also helps reduce the amount of material that blows onto the operator and the surface swept.

To swing the brush head assembly using a manual angle kit: remove the lock pin, swing the brush head to the desired angle by hand and then replace the lock pin.

Operating Tips

CAUTION! AVOID SWEEPER DAMAGE. Do not ram into plies of material. Use a dozer blade for this type of work.



Snow

For wet, heavy or deep snow, adjust support chains so the mounting assembly is 20-22 inch (508-559mm) off the ground with the unit lowered.

High brush speeds and slow ground speeds are needed to sweep snow effectively. Start at 3/4 throttle and the lowest gear of the prime mover. For wet and/or deep snow, increase to almost full throttle. This helps keep snow from packing up inside the brush hood.

In deep snow you may need to make more than one pass to get down to a clean surface.

To keep snow from blowing back onto a swept area, always sweep so the wind is at your back or so it follows the brush angle.

Dirt & Gravel

To keep dust at a minimum, plan your sweeping for days when it is overcast and humid or after it has rained. Sweep so the wind blows at your back or in the direction the brush head is angled.

Low brush speeds and moderate ground speeds work best for cleaning debris from hard surfaces. Brush speeds that are too fast tend to raise dust because of the aggressive sweeper action.

To sweep gravel, use just enough brush speed to “roll” the gravel, not throw it.

Heavy Debris

For 2 inches (51mm) or more of heavy debris, travel 5 mph (8 kph) or less.

Thatch

Low brush speeds and low prime mover speeds do the best thatching job.

To prevent the brush from pulling itself into the ground, adjust the spring-chain assembly so the bristle tips barely touch the grass.

OPERATION

If the brush pulls into the grass and stalls while sweeping, use the lift to raise the brush. Do not increase throttle to override a stall out.

Use a combination of brush speeds and ground speeds that rolls up a neat windrow.

To keep thatch from blowing back onto a swept area, sweep with the wind at your back or in the direction the brush is angled.

WARNING!



EXPOSURE TO RESPIRABLE CRYSTALLINE SILICA DUST ALONG WITH OTHER HAZARDOUS DUSTS MAY CAUSE SERIOUS OR FATAL RESPIRATORY DISEASE.

It is recommended to use dust suppression, dust collection and if necessary personal protective equipment during the operation of any attachment that may cause high levels of dust.

WARNING!



REMOVE PAINT BEFORE WELDING OR HEATING.

Hazardous fumes/dust can be generated when paint is heated by welding, soldering or using a torch. Do all work outside or in a well ventilated area and dispose of paint and solvent properly. Remove paint before welding or heating.

When sanding or grinding paint, avoid breathing the dust. Wear an approved respirator. If you use solvent or paint stripper, remove stripper with soap and water before welding. Remove solvent or paint stripper containers and other flammable material from area. Allow fumes to disperse at least 15 minutes before welding or heating.

STORAGE

NOTICE:

Do not store the sweeper with weight on the brush. Weight will deform the bristles, destroying the sweeping effectiveness.

Do not store polypropylene brushes in direct sunlight. The material can deteriorate and crumble before the bristles are worn out.

Keep polypropylene brush material away from intense heat or flame.

MAINTENANCE

SCHEDULE

For best performance, regularly maintain your sweeper. Carefully follow this schedule and other recommendations.

Procedure	Schedule				
	Before Each Use	After Each Use	Before Each Season	Refer to Tractor Manual	When Needed
Constant Velocity (CV) Drive Shaft - Lubricate with high-quality grease. (See Maintenance: Lubrication.)	✓				
Drive Chain - Check for adjustment. (See Maintenance: Adjusting Drive Chain.)	✓				
Remove chain from sprockets; soak in motor oil.		✓	✓		
To loosen stiff links, soak in penetrating oil; bend back and forth. Replace chain if this does not work.					✓
Hardware - Tighten	✓				
Lubrication Points - Lubricate with high-quality grease. (See Maintenance: Lubrication.)	✓				
Spring-Chain Assembly - Adjust. (See Adjustments: Adjusting Spring-Chain Assembly.)	✓				
Sprockets - Check Alignment. (See Maintenance: Aligning Sprockets.)	✓				
Tractor Air Cleaner - Check	✓				
Replace				✓	
Universal Joints - Check for wear. Tighten set screws and jam nuts.	✓				
Lubricate with high-quality grease. (See Maintenance: Lubrication.)					✓

Notes

MAINTENANCE

Reversing Sweeping Direction

All RHFA sweepers are shipped with the gearbox set to sweep forward while driving forward. To reverse the gearbox rotation to sweep while backing up:

1. Remove drive shafts and the shield from the gearbox (figure 1).
2. Remove the gearbox from the mounting assembly (figure 2)
3. Remove the vent plug and drain plug (figures 3 and 4). Reinstall plugs in the opposite holes. Tighten both plugs securely.
4. Reinstall the gearbox (figure 5). The vent plug must be on top of the gearbox.
5. Reinstall the gearbox shield (figure 6).

WARNING! AVOID SERIOUS INJURY OR DEATH. Do not operate the sweeper without all shields installed.



6. Install drive shafts on gearbox shafts. Tighten set screws and jam nuts.
7. Check gearbox lubricant level. Fill if necessary.
8. Operate the unit at a low rpm while observing for excessive vibrations or other problems. Correct before using the unit.

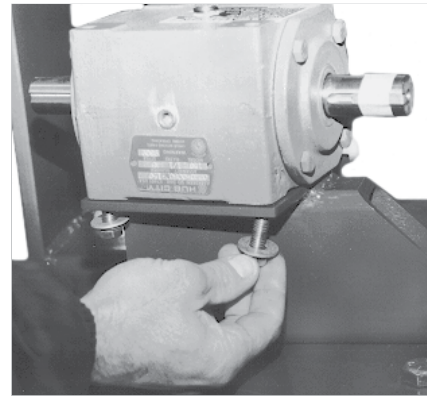

figure 2

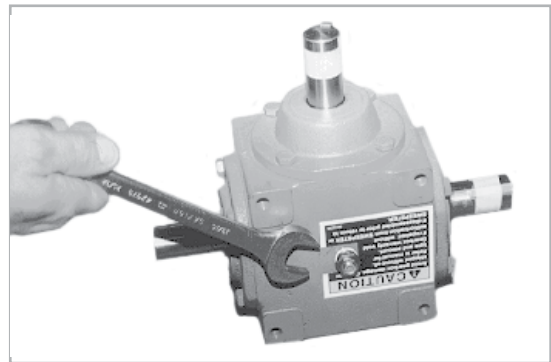

figure 3

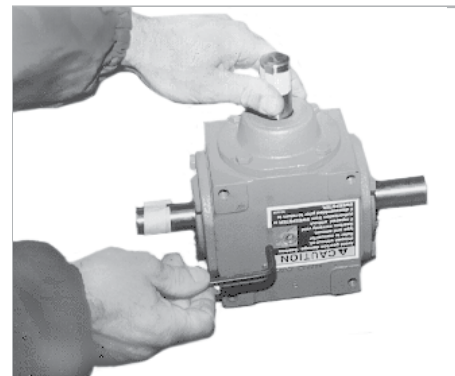

figure 4

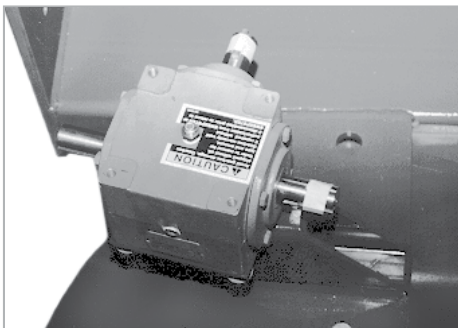

figure 1

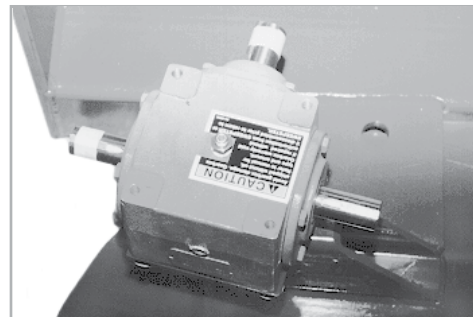

figure 5

MAINTENANCE

Adjusting Drive Chain



figure 6



figure 7

1. Remove the rear chain shield (figure 7).
2. Loosen but do not remove 4 bolts securing bearing assemblies on both sides of the brush head assembly (figures 8 and 9).
3. Slide the brush forward until there is 3/8 to 1/2 inch (10 to 13mm) of play in the chain.

CAUTION! AVOID DRIVE CHAIN AND SPROCKET DAMAGE. The drive chain must have 3/8 to 1/2 inch (12 to 13mm) of play. Overtightening wears the chain and sprockets prematurely.

4. Tighten 4 bolts on each bearing assembly to hold the assemblies in place.
5. Reinstall the rear chain shield.

WARNING! AVOID SERIOUS INJURY OR DEATH. Do not operate the sweeper without all shields in place.

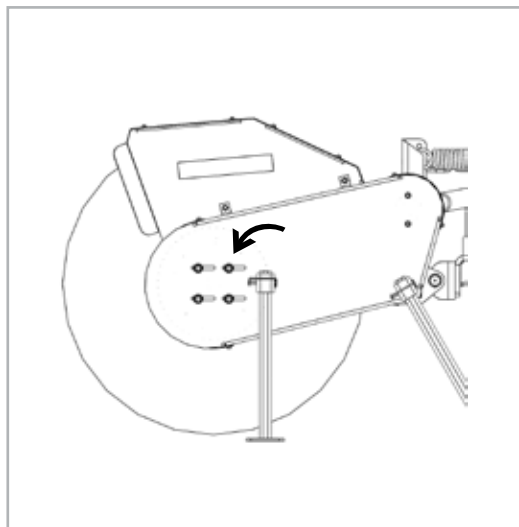

figure 8

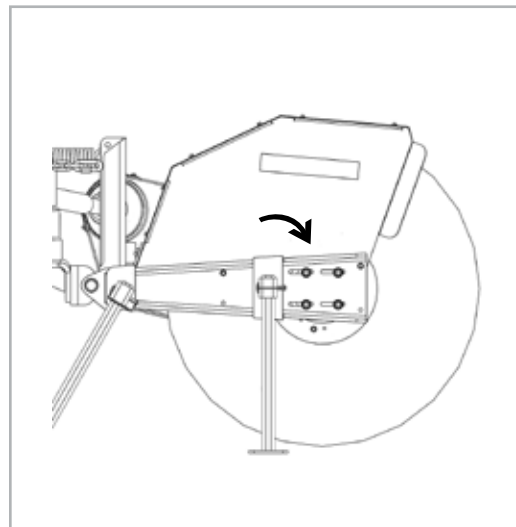

figure 9

MAINTENANCE

Aligning Sprockets

Keep sprockets aligned to prevent chain derailment and reduce wear on the drive chain and sprockets.

1. Remove front (figure 1) and rear (figure 2) chain shields from the fixed chain shield.
2. For each sprocket, measure from inside the fixed chain shield to the center of the chain (figure 3).
3. Compare measurements.
 - If they are the same, sprockets are aligned.
 - If they are different, loosen the set screw on the small sprocket. Adjust it until it is the same distance as the large one. Tighten the set screw.
4. Reinstall chain shields.

WARNING! AVOID SERIOUS INJURY OR DEATH. DO NOT OPERATE THE SWEEPER WITHOUT ALL SHIELDS IN PLACE.

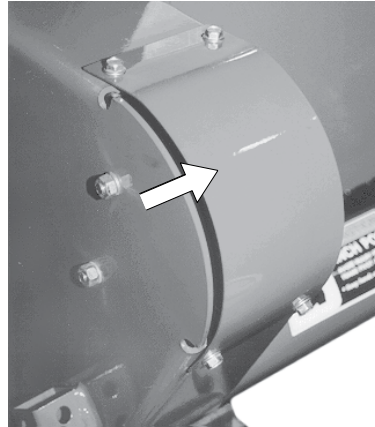

figure 1

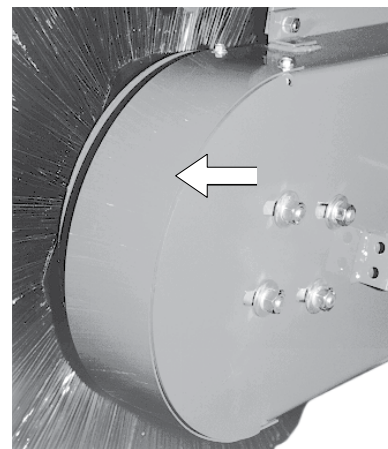

figure 2

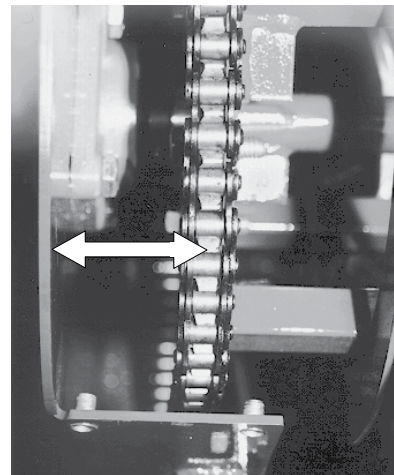

figure 3

Replacing Brush Sections

1. Loosen 4 carriage bolts holding each assembly (figures 4 and 5).
2. Remove front (figure 1) and rear (figure 2) chain shields.
3. Rotate the brush to locate the master link. Remove the master link and chain.
4. Pull the brush out from under the hood.
5. Stand the brush securely on blocks.

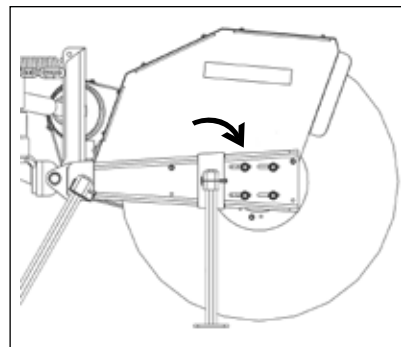

figure 4

MAINTENANCE

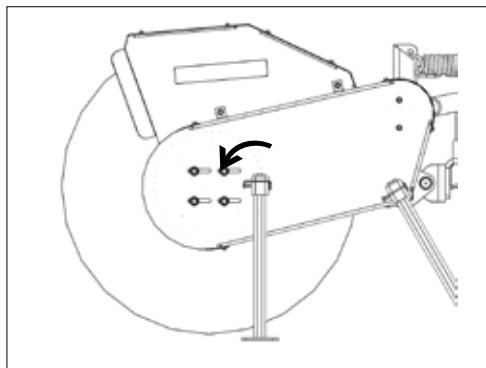

figure 5

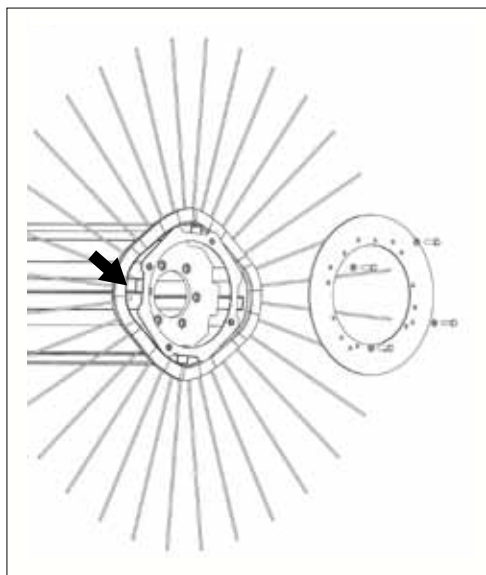

figure 6



figure 7

Worn Section Standard				Reference Information	
Section OD, New	Ring ID	Section OD, Worn	Exposed Bristle, Worn	Bristle Length	Exposed Bristle, New
24	6.38	17	3.8	8.50	7.5
26	8.00	18	4.0	9.00	8.0
32	10.00	22	5.0	11.00	10.0
36	10.00	24	6.0	13.00	12.0
36	10.63	25	6.0	12.69	11.4
46	19.38	34	6.0	13.31	12.1

6. Remove retainer plate (figure 6) from the end of the brush core.
7. Slide old sections off the core.
8. Slide the first, section onto the core (figure 6). Be sure drive pins (figure 6 and 7) straddle a tube.

NOTE: Drive pins must all angle up or angle down.

9. Install a second section with drive pins rotated 180° from those on the first section (figure 8).
10. Continue installing sections, rotating each section 180° until the core is full.

NOTE: If the last section will take more space than is left, but more than 1/2 inch (13mm) remains, nest the last section on the previous one. Do this by placing both sections' drive pins on one tube.

NOTE: With new brushes, bristles may bend into the chain. Trim them to prevent chain derailment.

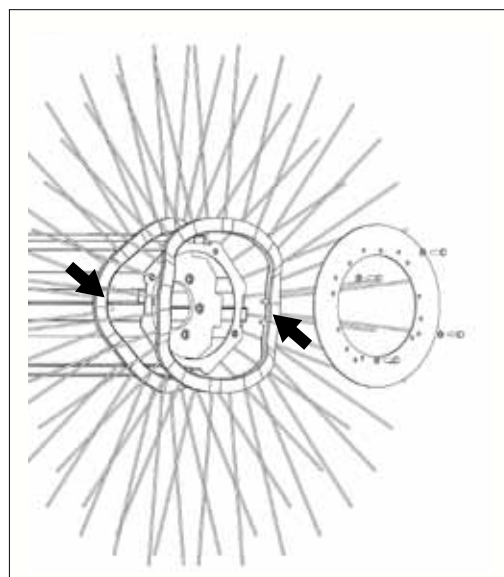

figure 8

MAINTENANCE

Lubrication

Zerk Fittings

Grease zerk fittings before each startup. Figure 1 shows locations.

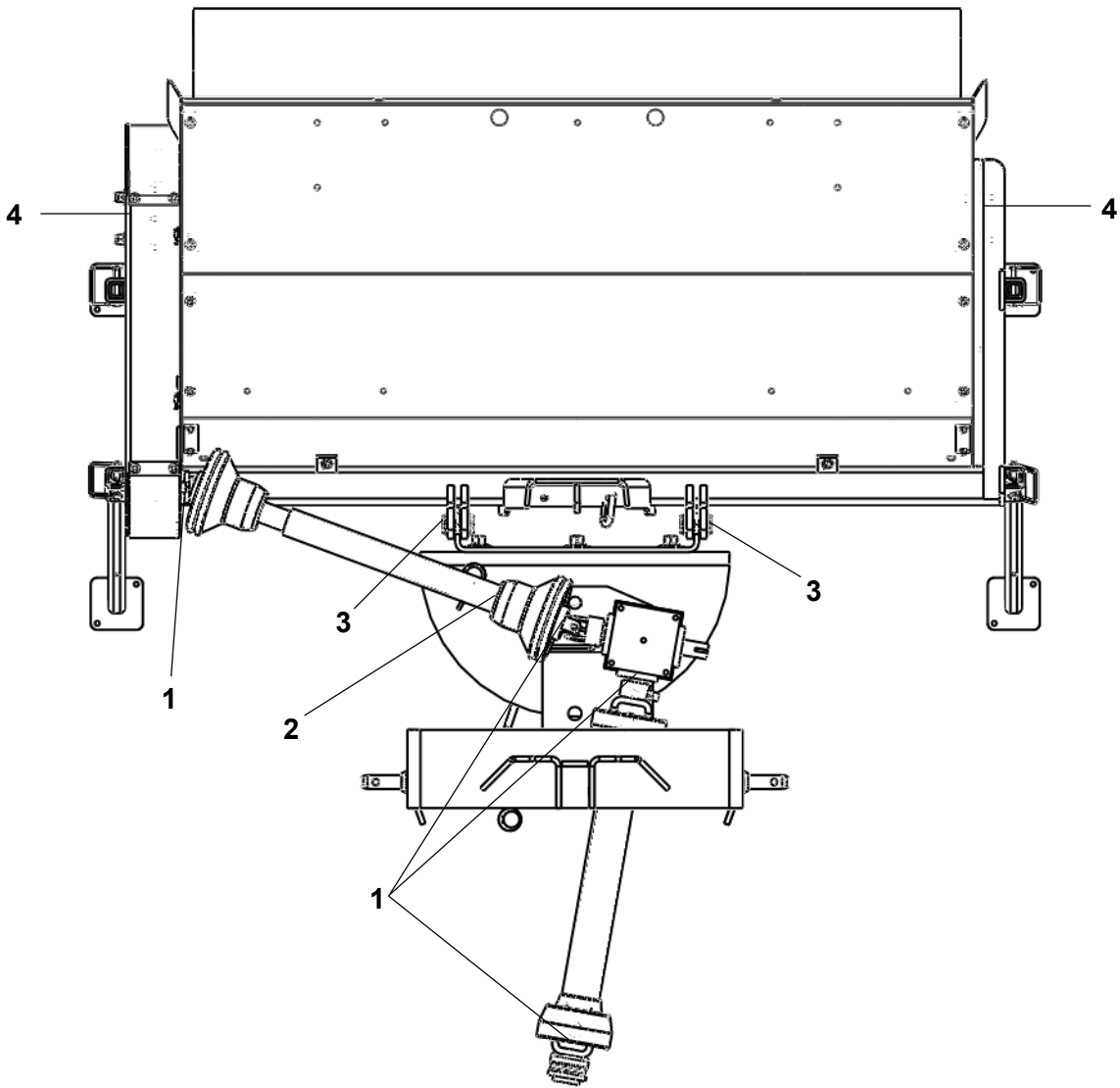

figure 1

1. U-joint
2. Constant velocity (CV) drive shaft
3. Brush head pivot (center bearing)
4. Bearing

MAINTENANCE

Gearbox

To check gearbox lubricant level, remove the side plug located in the hinged area of gearbox shield.

- If lubricant seeps out the hole, the gearbox is full.
- If not, add multipurpose 90-weight gear lubricant.

To add lubricant:

1. Remove the top and side plugs.
2. Pour multipurpose 90-weight rear lubricant into the top hole until lubricant runs out the side hole.
3. Replace both plugs.

Constant Velocity (CV) Drive Shaft

Lubricate the constant velocity (CV) drive shaft with high-quality grease to extend the life of the driveline. See figure 2 for intervals and locations.

Clean and grease the input driveline before each prolonged period of non-use.

To grease telescoping members without zerk fittings, pull apart and grease manually.

Check and grease guard tubes in winter to prevent freezing.

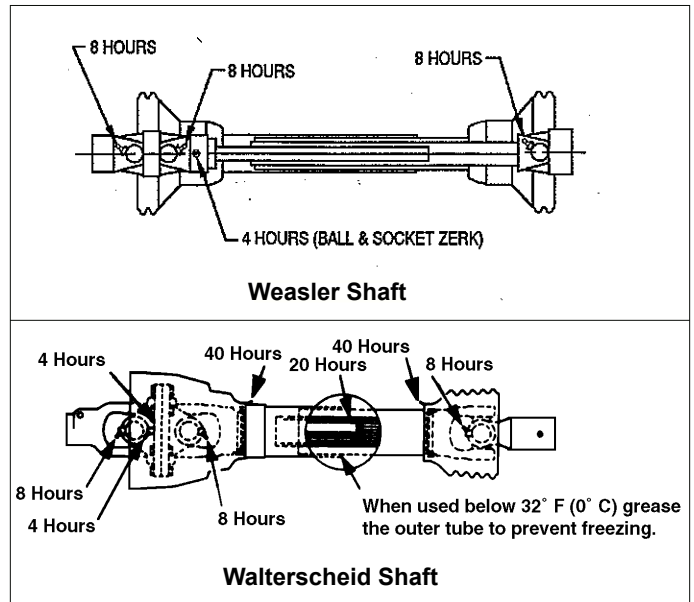

figure 2

TROUBLESHOOTING

Brush Head

Problem	Possible Causes	Possible Solution
Brush rotates wrong direction	Gearbox is flipped	Remove gearbox, switch breather cap and plug; remount gearbox
Brush head assembly "bounces" during sweeping	Spring-chain assembly needs adjustment	Adjust spring-chain assembly (See Maintenance: Adjusting Spring-Chain Assembly)
	Ground speed too fast and/or brush speed too slow	Find correct combination of ground and brush speeds
	Core is bent	Replace core
Brush wears unevenly	Brush head not level	Level brush head (See Adjustments: Leveling)
Brush wears very quickly	Spring-chain assembly not adjusted correctly	Adjust spring-chain assembly (See Maintenance: Adjusting Spring-Chain Assembly)
	Brush speeds too high	Use slower brush speeds
Drive chain falls off repeatedly	Sprockets not aligned	Align sprockets (See Maintenance: Aligning Sprockets)
	Too little tension on drive chain	Tighten drive chain (See Maintenance: Adjusting Drive Chain)

Gearbox

Problem	Possible Causes	Possible Solution
Gearbox does not turn	Broken shaft or gear	Do not open a gearbox still under warranty; contact Sweepster for replacement parts and service policy
Oil leaking from pinion housing, caps, cap screws or pipe plugs	Loose hardware	Retighten hardware or remove and coat with Loctite® before tightening; if necessary, replace gaskets
High internal operating temperature (above 200° F [93.33° C])	Damaged bearings	Replace bearings
	Too little oil	Add oil
Excessive end play of shafts (.005 inch [.13mm] or more) when couplings are removed	Worn bearings	Remove gaskets between caps and gear case; replace if necessary
Excessive backlash	Worn rears	Adjust gears; replace, if necessary

TROUBLESHOOTING

Constant Velocity (CV) Drive Shaft

Problem	Possible Causes	Possible Solution
End and/or inboard yoke ears spread	Drive shaft too long	Adjust drive shaft length; replace parts
	Axial forces too high - running above recommended rpm	Clean and grease profile tubes; replace parts; replace both tubes, if necessary
End yoke ears have pressure marks	Excessive bend angle when shaft rotates	Avoid running brush in raised position; switch off tractor PTO during cornering or when lifting the brush head; replace parts
End yoke bearing caps blued	Insufficient lubrication	Follow lubrication instructions (See Maintenance: Lubrication) replace parts
Inboard yoke ears have pressure marks	Excessive bend angle when shaft rotates	Avoid running brush in raised position; switch off tractor PTO during cornering or when lifting the brush head; replace parts
	Drive shaft too long	Adjust drive shaft length
Inboard yoke bearing caps blued	Insufficient lubrication	Follow lubrication instructions; replace parts
Shield tube deformed and split on one side	Shield tube too short or no overlap at all when drive shaft is extended	Adjust shield tube length; replace parts
Shield tubes damaged	Shields contact components on tractor and/or sweeper	Allow more clearance; replace parts
Shield cone destroyed	Shields contact components on tractor and/or sweeper	Allow more clearance; replace parts
Telescoping sections distorted	Overload caused by high starting and peak torques or blocking	Engage and disengage at idle; replace parts

Telescoping Shaft

Problem	Possible Cause	Possible Solution
Shaft bent	Tractor toplink not adjusted correctly	Adjust tractor toplink so swing frame is perpendicular to ground

BRUSH HEAD

Item	Part	Qty	Description
1.	05-0859	1	Shaft, 7/8 Hex (7,8ft)
2.	05-0983	1	Shaft, Tele, 7/8 Hex (5,6ft)
3.	06-0086	1	Chain, #60 x 88, with Master
4.	06-0180	1	Sprocket, 60B11 x 7/8 Hex
5.	06-0208	1	Sprocket, 60A48 x 1 1/4 RD
6.	07-0002	1	Screw, Set, Gr2, 5/16-18 x 5/16
7.	07-0239	1	Pin, Spring, Lock, Gr2, 3/16 x 1 1/4
8.	07-1557	2	Chain, 1/4, 27 Links
9.	07-1597	2	Rivet, Pop, Aluminum 3/16 x 1/2
10.	07-1607	4	Pin, Lock, 5/16 Sq Bail Leg Lock
11.	07-2952	24	Screw, HFH, CL10.9, M6-1 x 20
12.	07-3375	4	Lanyard, 1/16 Cable, 1 1/4 Tab
13.	07-3617	25	Nut, Insert, M6 x 1, Hex
14.	07-3737	4	Nut, Hex, CL10, M8-1.25
15.	07-3738	4	Washer, Lock, Split, Medium, M8
15.	07-3745	8	Washer, Flat, CL8.8, M10
16.	07-3747	14	Washer, Lock, Split, Medium, M10
18.	07-3750	18	Screw, HHC, CL10.9, M10-1.5 x 35mm
19.	07-3754	8	Washer, Flat, CL10.9, M12
20.	07-3755	8	Nut, Hex, CL10.9, M12-1.75
21.	07-3756	8	Washer, Lock, Split, Medium, M12
22.	07-3761	4	Screw, HHC, CL10.9, M12-1.75 x 45mm
23.	07-3842	4	Ring, Snap
24.	07-3922	8	Nut, Insert, M6 x 1, Grip Length .165-.251
25.	07-4514	2	Nut, Hex, CL10.9, M10-1.5
26.	07-4622	4	Nut, Hex, Lock, CL10.9, M10-1.5
27.	07-5294	2	Link, Quick, 5/16, Wide Jaw
28.	07-5933	4	Bolt, Carriage, CL8.8, M8-1.25 x 25mm
29.	07-6451	1	Spring, Tension, 325 #/IN
30.	08-0029B	2	Flange, Bearing, 2 Hole
31.	08-0034	2	Bearing, 7/8 Hex, with Hole
32.	08-0067	2	Bearing, 1 1/4, 4 Bolt
33.	11-3725-48	1	Shaft, Hex, 7/8 x 6 1/2
34.	13-0798	2	Weld, Leg, Rear
35.	13-0799	2	Weld, Leg, Front
36.	13-10004	2	Pin, Pivot, Lift, Arm, QA
37.	13-12617	1	Plate, Mounting, Brush Head
38.	13-13281	1	Sheet, Hood (5ft)
	13-13282	1	Sheet, Hood (6ft)
	13-13049	1	Sheet, Hood (7ft)
	13-13283	1	Sheet, Hood (8ft)
39.	13-15247	4	Tube, Round, 5/8 x 12GA x .375
40.	13-16230	1	Weld, Core End
41.	13-16231-5	1	Weld, Brush Frame (5ft)
	13-16231-6	1	Weld, Brush Frame (6ft)
	13-16231-7	1	Weld, Brush Frame (7ft)
	13-16231-8	1	Weld, Brush Frame (8ft)

BRUSH HEAD

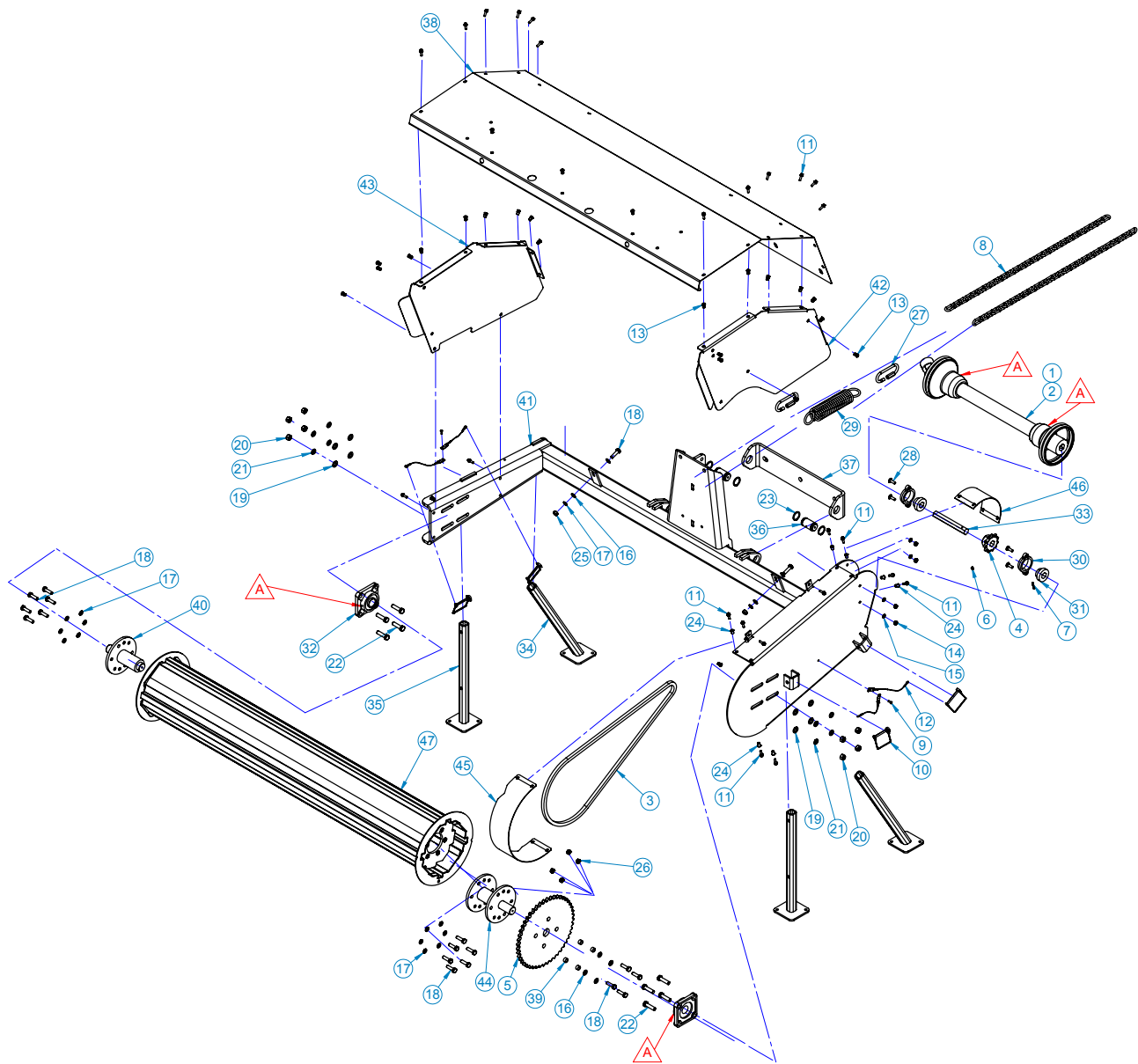

Item	Part	Qty	Description
42.	13-16352	1	Sheet, Hood, Side, Drive
43.	13-16353	1	Sheet, Hood, Side, Bearing
44.	13-16354	1	Weld, Core, End, Drive
45.	13-8256	1	Plate, Chain, Guard, Front
46.	13-8257	1	Plate, Chain, Guard, Rear
47.	28-10095-5	1	Assembly, Core, 10, (5ft)
	28-10095-6	1	Assembly, Core, 10, (6ft)
	28-10095-7	1	Assembly, Core, 10, (7ft)
	28-10095-8	1	Assembly, Core, 10, (8ft)

MOUNTING ASSEMBLY

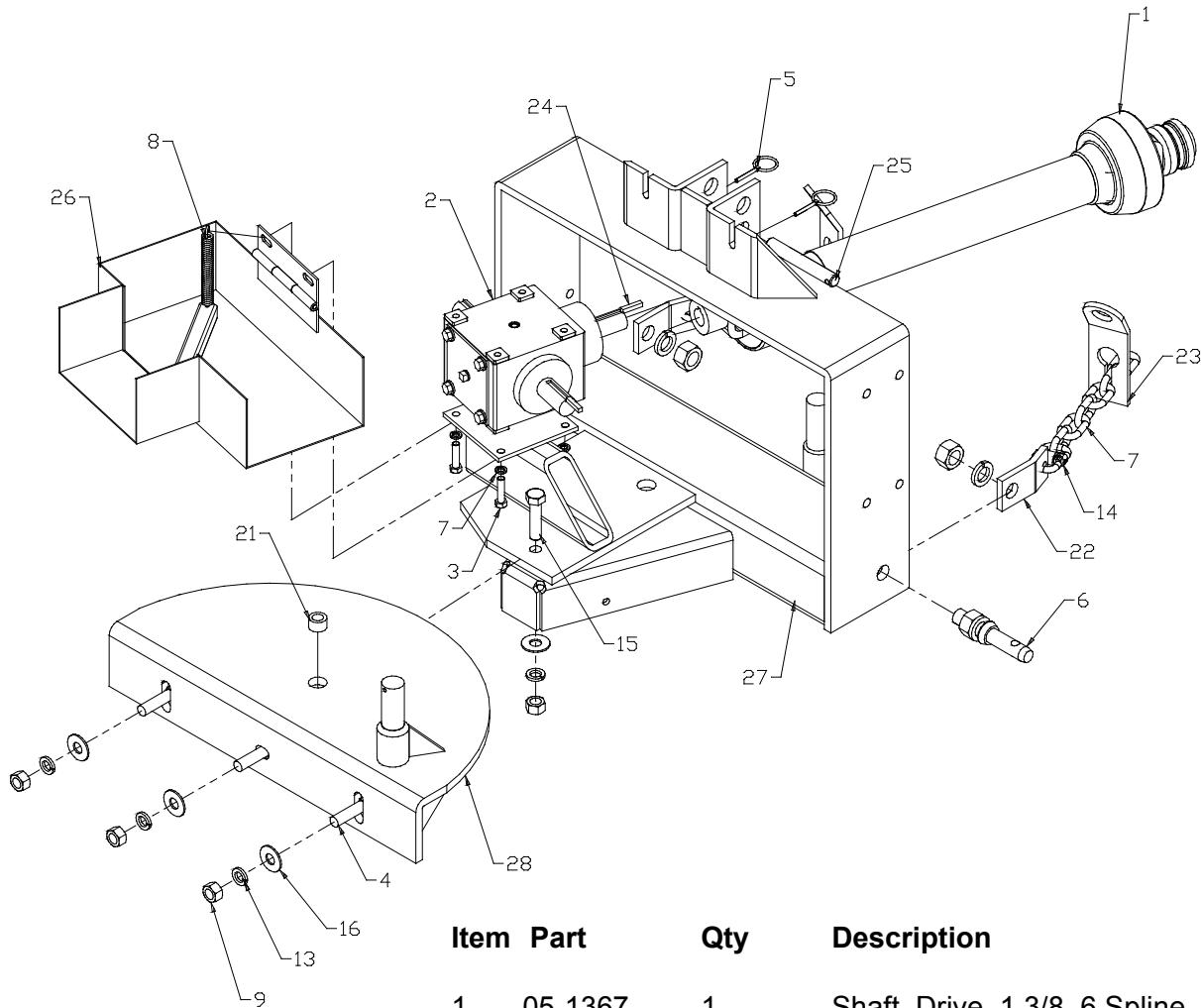

Item	Part	Qty	Description
1.	05-1367	1	Shaft, Drive, 1 3/8, 6 Spline
2.	05-1111	1	Gearbox, Hubcity, 1:1, 3 Shafts
3.	07-0018	4	Screw, HHC, Gr8, 3/8-16 x 1
4.	07-0119	3	Bolt, Carriage, Gr5, 5/8-1 x 1 3/4
5.	07-0244	2	Pin, Linch, 1/4
6.	07-0285	2	Pin, CAT I
	07-0688	2	Pin, CAT II
7.	07-0290	2	Chain, 1/4, 39 Links
8.	07-0324	1	Spring Tension, 1/2 x 3
9.	07-1294	4	Nut, Hex, Gr8, 5/8-11
10.	07-1718	6	Washer, Lock, Split, Medium, 3/8
13.	07-1872	4	Washer, Lock, Split, Medium, 5/8
14.	07-2032	2	Clevis, Double Link, 9/32, Gr80
15.	07-2855	1	Screw, HHC, Gr8, 5/8-11 x 2 1/2
16.	07-3120	4	Washer, Flat, Gr8, 5/8
21.	13-4657	1	Bushing, 1 x 5/8 x .562
22.	11-1888	2	Plate, Support, Chain
23.	13-0440	2	Bracket, Chain, Toplink
24.	13-1430	2	Key, 1/4 x 1 1/4
25.	13-2002	1	Pin, Toplink, 3-Point
26.	13-3215	1	Shield, Gearbox
27.	13-4614	1	Weld, Frame, Swing
28.	13-4823	1	Weld, Swing, Plate

DRIVE SHAFTS

Replacement Parts

NOTE - If a shaft becomes bent or damaged or will not telescope, the entire shaft must be replaced.

Drive Shaft 05-0983 (for 5 & 6 Ft)

Part	Description
05-0984	Shaft, Half, 1 Rd End
05-0985	Shaft, Half, Hex End
05-0986	Shield, Half, 1 Rd End
05-0987	Shield, Half, Hex End
07-0573	Kit, U-Joint, Cross, Repair

Drive Shaft 05-0859 (for 7 & 8 Ft)

Part	Description
05-0914	Shaft, Half, 1 Rd End
05-0915	Shield, Half, 7/8 Hex End
05-1251	Kit, U-Joint, Cross, Repair

Drive Shaft 05-0857

Part	Description
05-0924	Shield, Outer, Splined End
05-0925	Shield, Inner, 1 Round End
05-0686	Bearing

GEARBOX

Gearbox 05-1111
1:1 Ratio

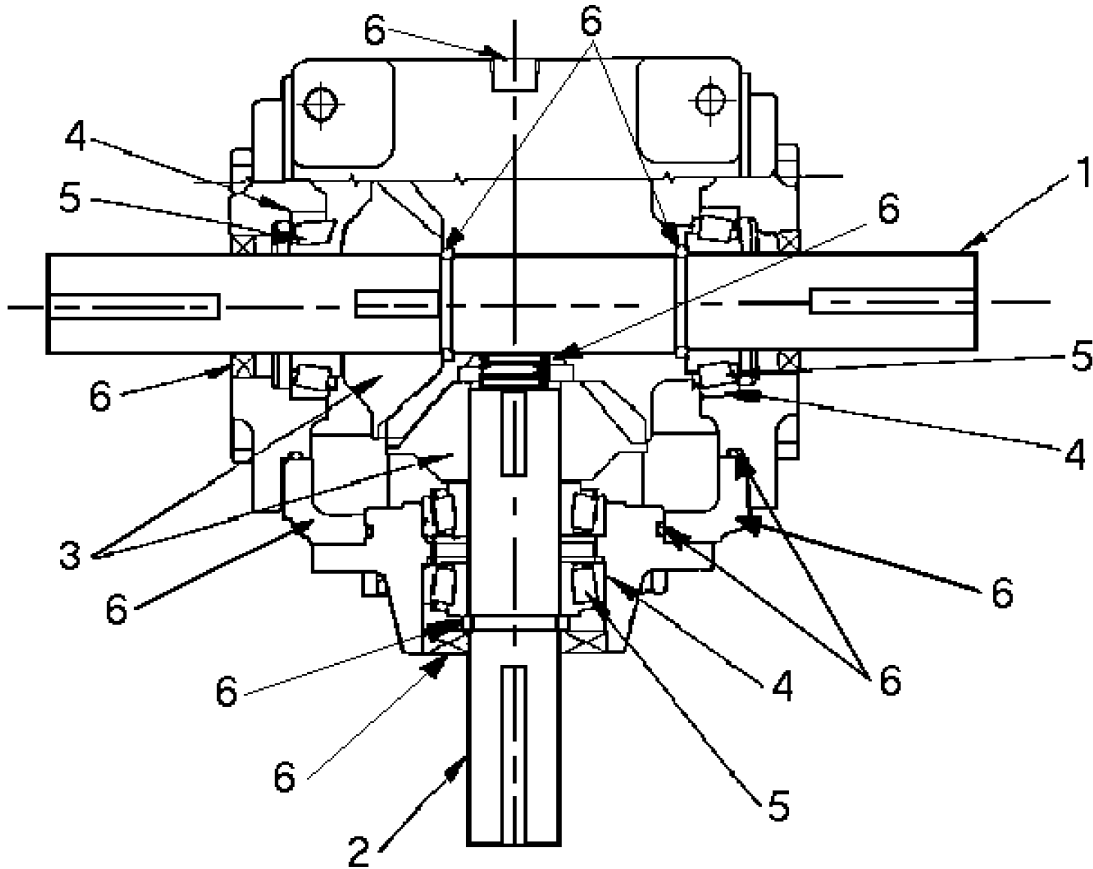

Item	Part	Qty	Description
1.	05-1136	1	Shaft, Cross
2.	05-1137	1	Shaft, Pinion
3.	05-0503	2	Gear, Straight Bevel
4.	05-0507	4	Cone, Bearing
5.	05-1162	4	Cup, Bearing
6.	05-1138	1	Kit, Repair

ANGLE KITS

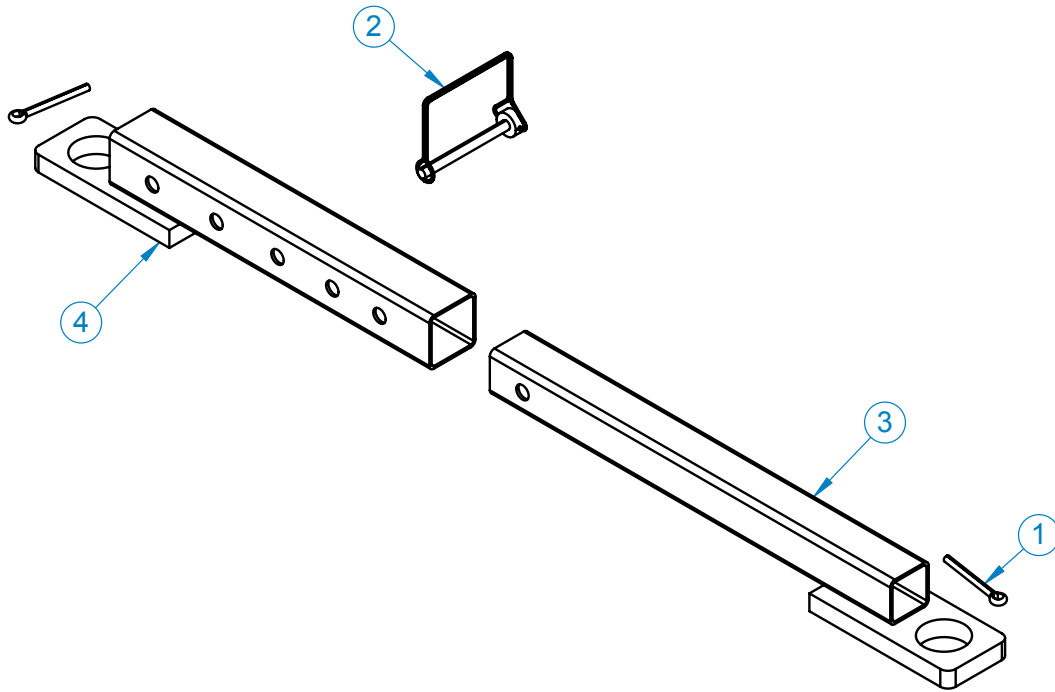

Item	Part	Qty	Description
1.	07-0206	2	Pin, Cotter, Gr2, 3/16 x 2
2.	07-2105	1	Pin, Lock, 3/8, Square Bail
3.	13-4199	1	Weld, Link, Inner, 15 1/4-21 1/4
4.	13-4200	1	Weld, Link, Outer, 15 1/4-21 1/4

ANGLE KITS

Hydraulic Angle
To Order, ask for kit 11-4297 or 11-4298

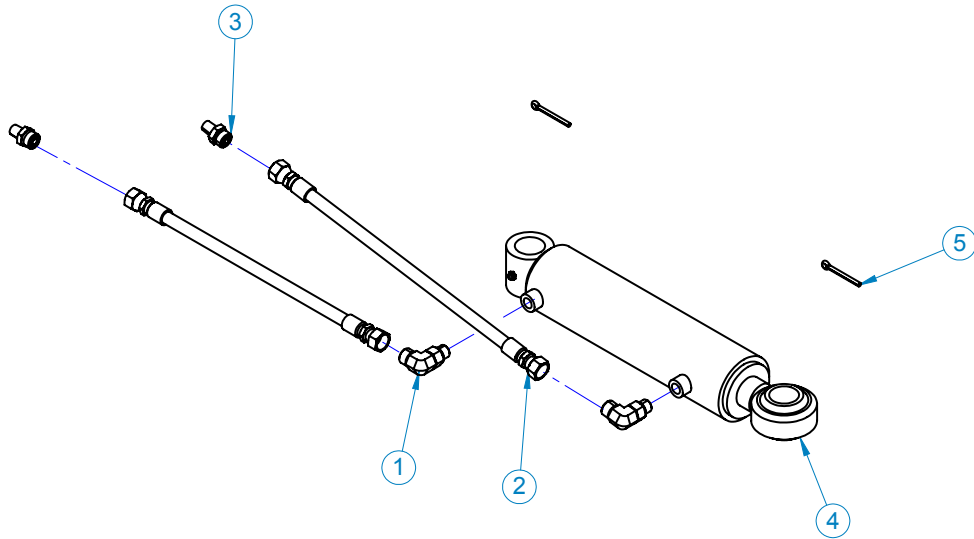

Item Part Qty Description

1.	03-2092	2	Elbow, 90°, 6MB-6MF
2.	03-2155	2	Hose, .25 x 72, 6FF-6FF, 3.25K (11-4298)
	03-2158	2	Hose, .25 x 144, 6FF-6FF, 3.25K (11-4297)
3.	03-2159	2	Fitting, 6MF-4MP
4.	03-4887	1	Cylinder, 2.5 x 1.38 x 7.5, 3.5K
6.	07-0206	2	Pin, Cotter, Gr2, 3/16 x 2

Replacement Parts for 03-4887 :

03-4888 Seal Kit
03-5035 Rod

DIRT DEFLECTOR

Installation

To order, ask for RHFADD

1. Attach each angle to the deflector shield with a bolt, flat washer, lock washer and hex nut. Do not tighten the hardware completely.
2. Position the deflector shield behind the mounting assembly (figure 1).
3. Fasten each of the two center angles to the frame with a bolt, lock washer and hex nut. Holes are predrilled in the frame for this step (figure 1).
4. Use a transfer punch to locate holes in the frame for the outer angles.
5. Drill holes with a 13/32 inch bit.
6. Fasten each of the outer angles with a bolt, lock washer and hex nut. Holes are cut in the opposite (front) side of the frame to make it easier to attach the washers and nuts.
7. Tighten all hardware securely.

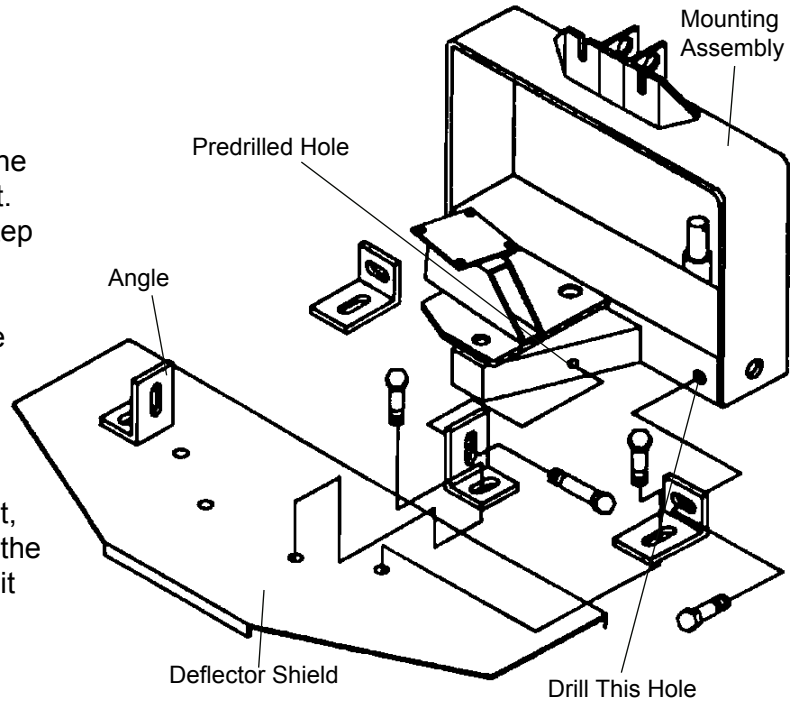
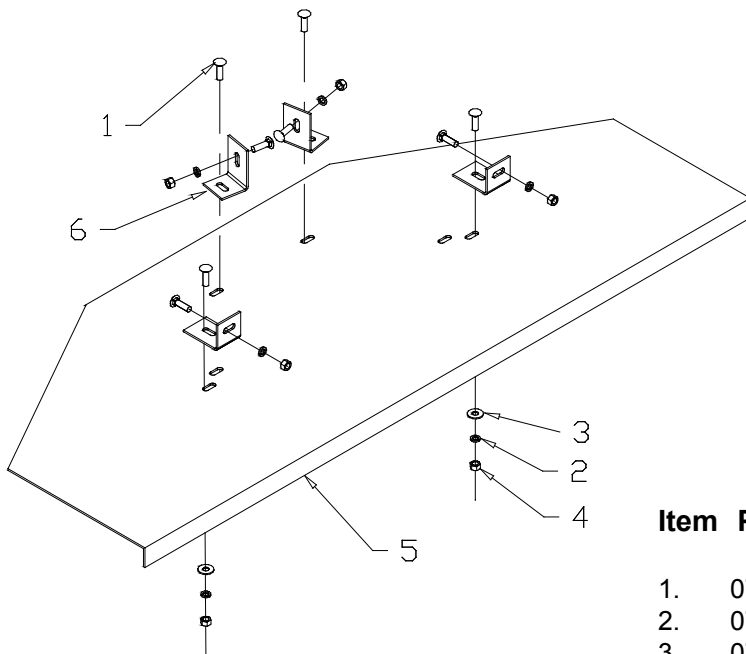
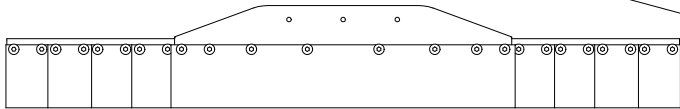
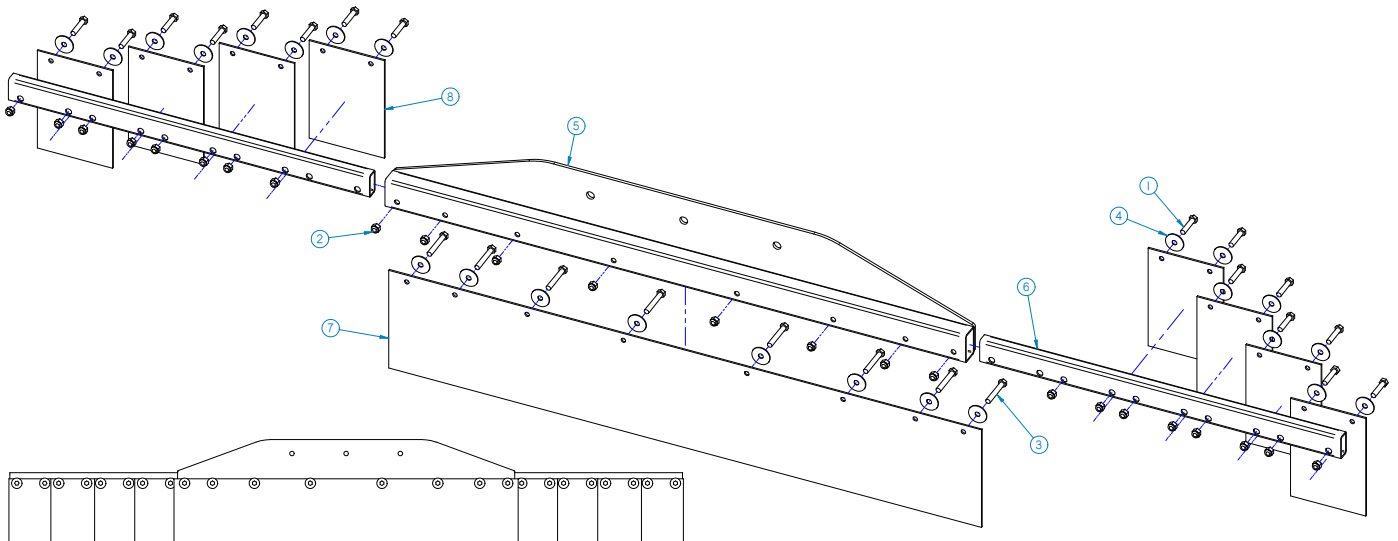

figure 1



Item	Part	Qty	Description
1.	07-1717	8	Bolt, Carriage, 3/8-16 x 1 1/4
2.	07-1718	8	Washer, Lock, Split, 3/8
3.	07-3279	4	Washer, Flat, 3/8
4.	07-3654	8	Nut, Hex, 3/8-16
5.	11-9491	1	Deflector, Dirt
6.	13-0351	4	Angle, Mounting

DIRT DEFLECTOR



8 FOOT CONFIGURATION

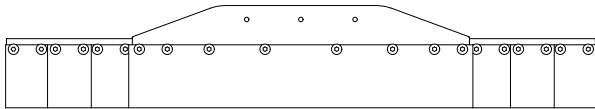

7 FOOT CONFIGURATION

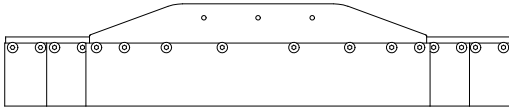

6 FOOT CONFIGURATION

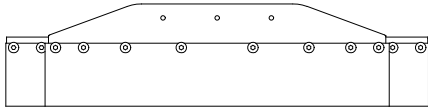

5 FOOT CONFIGURATION

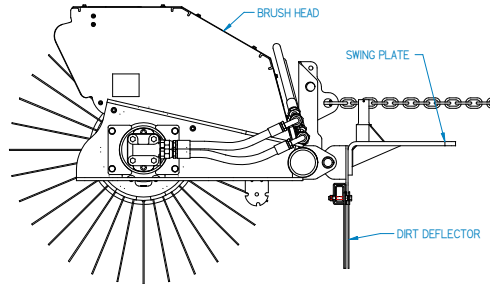

Item	Part	Qty	Description
1.	07-3656	16	Screw, HHC, Gr8, 3/8-16 x 1 3/4
2.	07-4036	24	Nut, Hex, Nylock, 3/8-16
3.	07-4053	8	Screw, HHC, Gr8, 3/8-16 x 2 1/2
4.	07-5030	24	Washer, Fender, 3/8 x 1 1/2
5.	13-14789	1	Weld, Mounting, Dirt Deflector
6.	13-14792	2	Tube, Rectangular, 2 x 1 x 1/8 x 30, with Holes
7.	13-14793	1	Flap, Middle
8.	13-14794	8	Flap, Side

180° HOOD KITS WITH DRAPE

Factory Installed

- 28-9787 5 Ft
- 28-9788 6 Ft
- 28-9789 7 Ft
- 28-9790 8 Ft

RETAINER STRAP COMBINATIONS

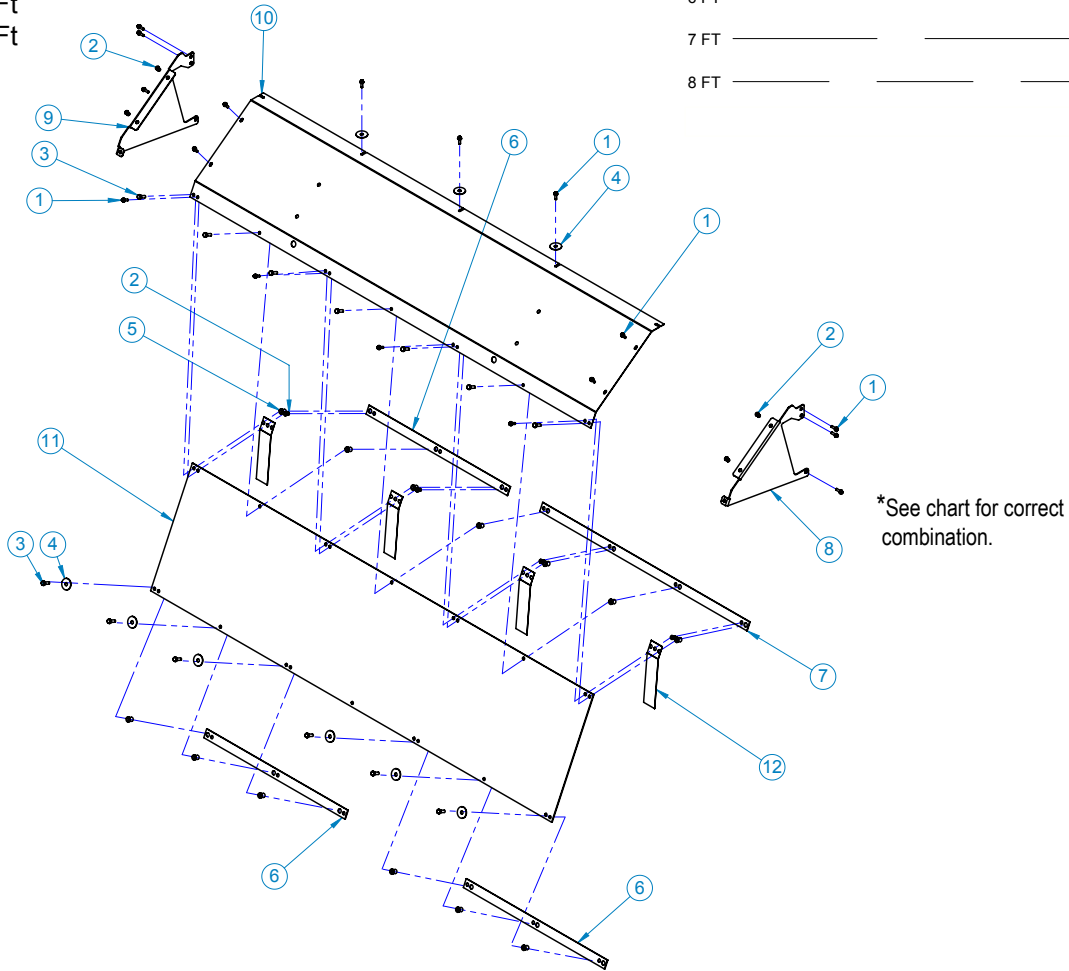
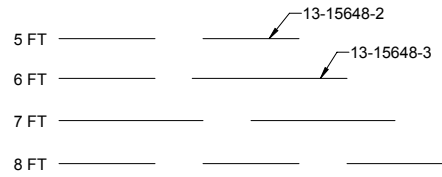

Item	Part	Qty	Description	Item	Part	Qty	Description
1.	07-3522	17	Screw, HFH, CL10.9, M6-1 x 20	8.	13-16045	1	Sheet, Hood, Extension, Side, Left
2.	07-3617	8	Nut, Insert, Hex, M6 x 1	9.	13-16046	1	Sheet, Hood, Extension, Side, Right
3.	07-3739	12	Screw, HHC, CL10.9, M8-1.25 x 25mm (5ft)	10.	13-16047-5	1	Sheet, Hood, Extension, 5 Ft
	07-3739	13	Screw, HHC, CL10.9, M8-1.25 x 25mm (6ft)		13-16047-6	1	Sheet, Hood, Extension, 6 Ft
	07-3739	14	Screw, HHC, CL10.9, M8-1.25 x 25mm (7ft)		13-16047-7	1	Sheet, Hood, Extension, 7 Ft
	07-3739	15	Screw, HHC, CL10.9, M8-1.25 x 25mm (8ft)		13-16047-8	1	Sheet, Hood, Extension, 8 Ft
4.	07-4942	9	Washer, Fender, 5/16 x 1	11.	13-16199-5	1	Flap, Deflector, 180° Hood 5 Ft
5.	07-7115	12	Nut, Insert, M8-1.25 (5ft)		13-16199-6	1	Flap, Deflector, 180° Hood 6 Ft
	07-7115	13	Nut, Insert, M8-1.25 (6ft)		13-16199-7	1	Flap, Deflector, 180° Hood 7 Ft
	07-7115	14	Nut, Insert, M8-1.25 (7ft)		13-16199-8	1	Flap, Deflector, 180° Hood 8 Ft
	07-7115	15	Nut, Insert, M8-1.25 (8ft)	12.	13-16200	4	Plate, Spring, 180°, Hood, Flap
6.	13-15648-2	4	Plate, Retainer, Flap, 2 Ft (5ft)				
	13-15648-2	3	Plate, Retainer, Flap, 2 Ft (6ft)				
	13-15648-2	2	Plate, Retainer, Flap, 2 Ft (7ft)				
	13-15648-2	5	Plate, Retainer, Flap, 2 Ft (8ft)				
7.	13-15648-3	0	Plate, Retainer, Flap, 3 Ft (5ft)				
	13-15648-3	1	Plate, Retainer, Flap, 3 Ft (6ft)				
	13-15648-3	2	Plate, Retainer, Flap, 3 Ft (7ft)				
	13-15648-3	0	Plate, Retainer, Flap, 3 Ft (8ft)				

180° HOOD KITS

<u>Field Installed</u>	<u>Factory Installed</u>
28-9722 5 Ft	28-9783 5 Ft
28-9723 6 Ft	28-9784 6 Ft
28-9724 7 Ft	28-9785 7 Ft
28-9725 8 Ft	28-9786 8 Ft

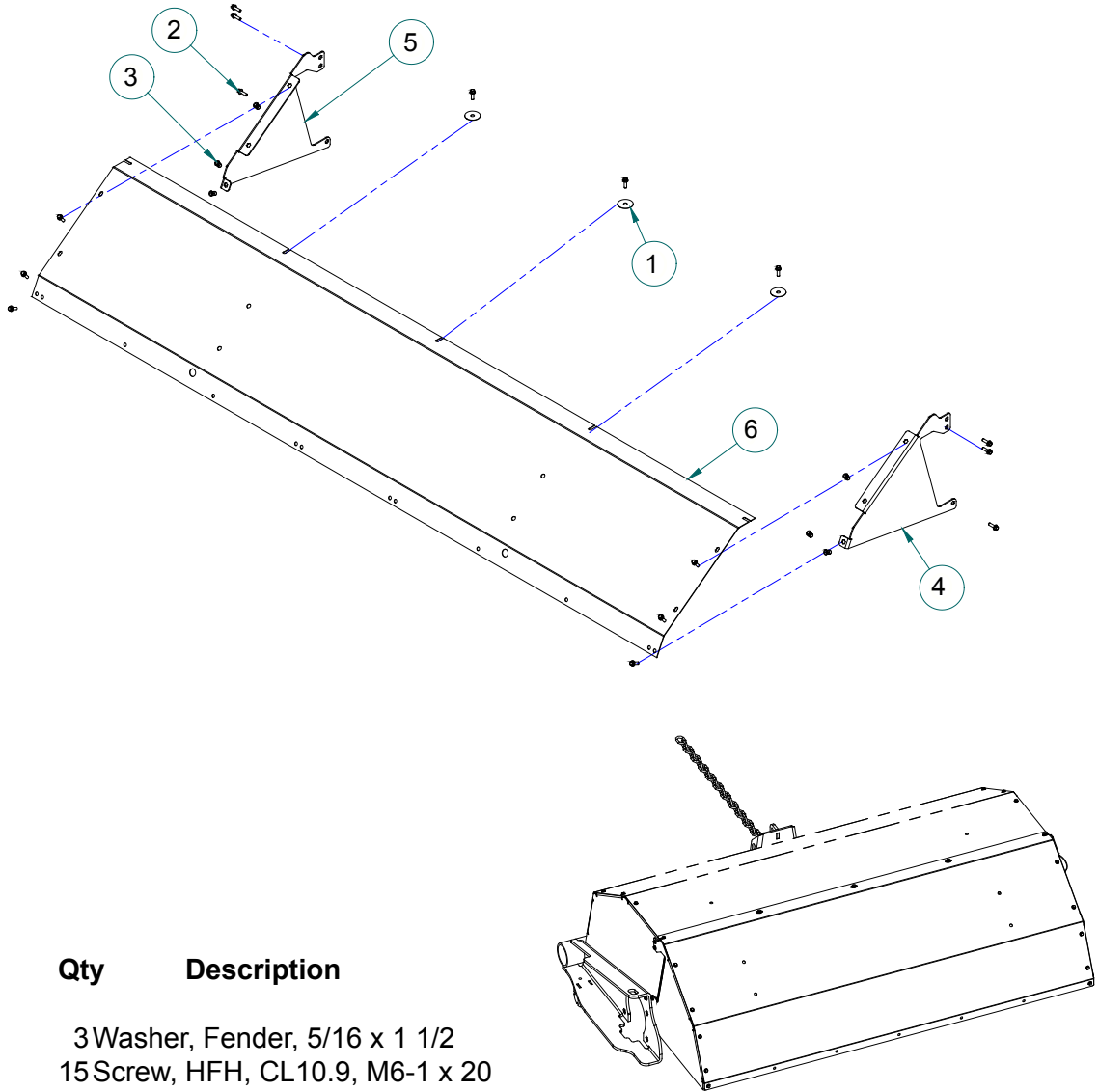

Item	Part	Qty	Description
1.	07-4942	3	Washer, Fender, 5/16 x 1 1/2
2.	07-3522	15	Screw, HFH, CL10.9, M6-1 x 20
3.	07-3617	6	Nut, Insert, Hex, M6 x 1
4.	13-16045	1	Sheet, Hood, Extension, Side, Left
5.	13-16046	1	Sheet, Hood, Extension, Side, Right
6.	13-16047-5	1	Sheet, Hood, Extension 5 Ft
	13-16047-6	1	Sheet, Hood, Extension 6 Ft
	13-16047-7	1	Sheet, Hood, Extension 7 Ft
	13-16047-8	1	Sheet, Hood, Extension 8 Ft

SPRINKLER

Installation

1. Install the tank, pump and strainer. Follow steps a through i to mount a tank purchased from SWEEPSTER.
 - a. Clamp the tank mounting plate to the mounting assembly with a 10 inch (254mm) distance between the top of the mounting frame and the underside of the tank mounting plate (figure 1). Be sure the front edge of the mounting frame and the front edge of the tank mounting plate are flush (figure 1).
 - b. Transfer punch holes in the tank mounting plate onto the mounting frame.
 - c. Remove the tank mounting plate.
 - d. Drill holes with a 17/32 inch bit.
 - e. Attach the tank mounting plate to the mounting frame using 8, 1/2 x 1 1/2 inch (13 x 38mm) cap screws, lock washers and nuts provided with the water tank kit.
 - f. Secure the water tank to the tank mounting plate with 4, 5/16 x 3/4 inch (8 x 19mm) cap screws, lock washers and flat washers provided in kit.
 - g. Attach the pump and strainer, provided, to the inside of the tank mounting plate with 4, 1/4 x 1 1/4 inch (6 x 32mm) cap screws, flat washers and nuts provided in kit (figure 2).
 - h. Install fittings on the tank in the following order: elbow fitting, shut-off valve, reducer fitting and barb fitting.
 - i. Connect the 7 ft. (2.1m) hose, provided with sprinkler kit, from the barb fitting to the strainer. Secure with 7/8 inch (22mm) spring clamps.
2. Attach quick disconnect terminals to the water pump motor with the male to the red wire and the female to the black wire. Then, connect quick disconnect terminals to the wire cord with

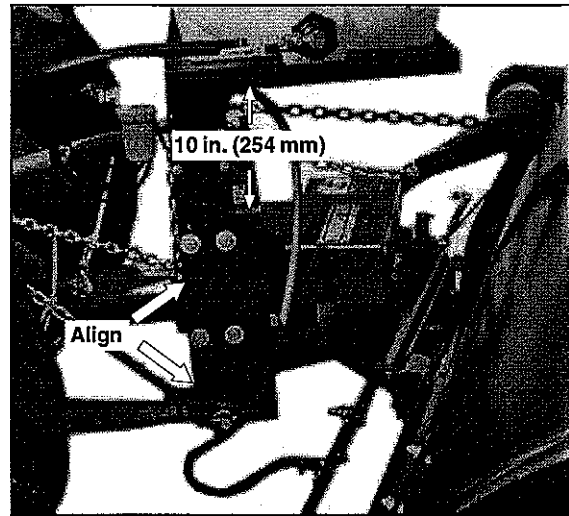

figure 1



figure 2

the female to the white wire and the male to the black wire.

CAUTION! AVOID EQUIPMENT DAMAGE.



Before drilling, check to make sure that you will not drill into any wires or other objects.

3. Install the control switch, provided with the sprinkler system kit.
 - a. Install the control switch in a convenient location on the prime mover.
 - b. Attach one wire from the control switch to Accessory and another wire to a white wire.

SPRINKLER

c. Run a black wire to a good ground on the prime mover.

4. Attach the spray bar to the brush hood.

To use this kit while driving forward:

a. Install spray bar mounting plates on the spray bar assembly.

NOTE: When installing without the water tank kit, make mounting plates. See figure 3 for dimensions.

b. Clamp mounting plates on the brush hood. See figure 3 for correct plates to use. Place top holes in the mounting plates 10 inch (254mm) from the bottom of the hood (figure 4). Center the spray bar from left to right.

c. Transfer punch holes from the mounting plates onto the brush hood.

d. Remove the spray bar assembly.

e. Drill holes with a 13/32 inch bit.

f. Attach the spray bar assembly to the brush hood with 4, 3/8 x 1 (10 x 25mm) cap screws, flat washers and nuts provided with tank kit.

To use this kit while driving in reverse, attach the spray bar assembly with 4, 3/8 x 1 (10 x 25mm) carriage bolts, flat washers, lock washers and nuts. Use holes pre-drilled in the top edge of the brush hood.

NOTE: Do not use the spray bar mounting plates provided in the tank kit.

5. Connect the 25 ft, 26 1/4 ft or 27 1/2 ft (7.6m, 8m, or 8.3m) hose from the spray bar assembly to the pump. Secure with 5/8 inch (16mm) spring clamps.

6. For sprinkler systems using the water tank kit, install the lift safety feature.

a. Place the carriage bolt, washer and lock nut, provided, in the 3-point lift lever bracket.

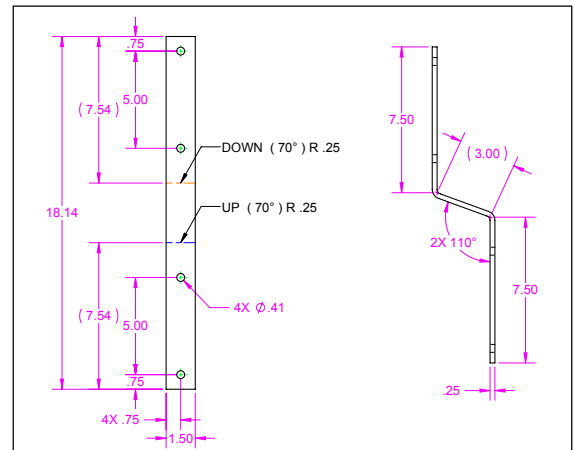
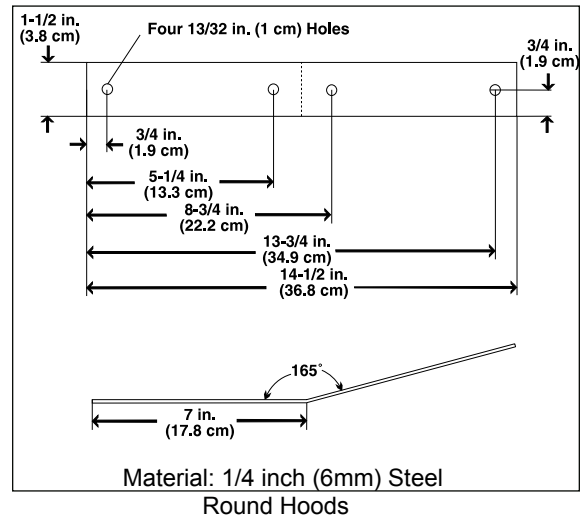

figure 3

Flat Hoods

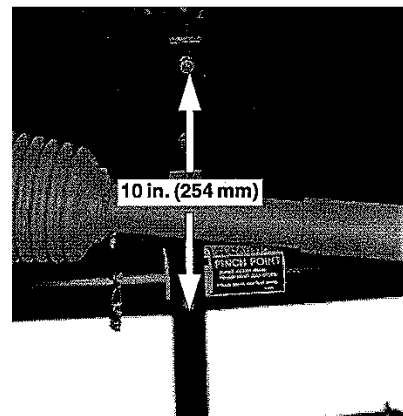
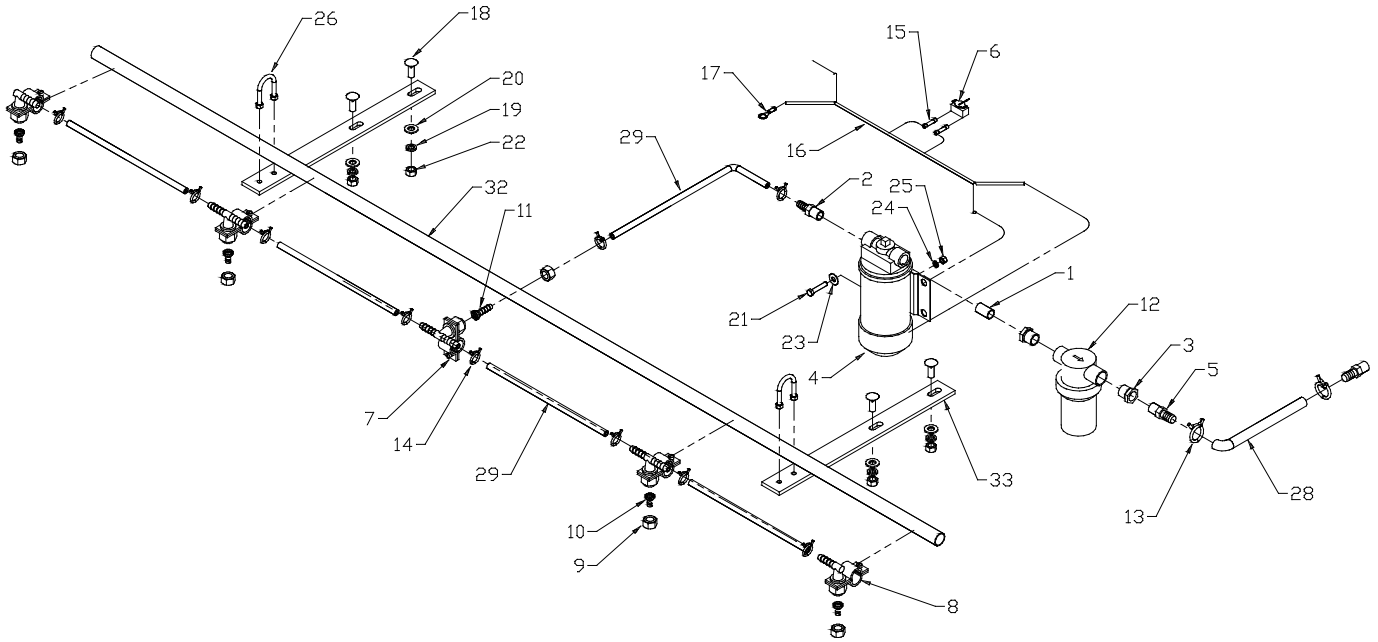

figure 4

b. Lift the unit so the brush is off the ground but the tank does not hit any part of the prime mover.

c. Adjust the bolt so it does not allow the lever to lift the unit any further. Tighten the hardware.

SPRINKLER



Item	Part	Qty	Description	Item	Part	Qty	Description
1.	03-0076	1	Fitting, Nipple, BP, Close, 3/8	16.	07-0917	20ft	Wire, Bulk, Cord, 16 gauge
2.	03-0457	1	Fitting, Barb, Nylon, 3/8-3/8 MP	17.	07-0929	1	Terminal, Ring, 3/8, 16-14
3.	03-0819	2	Fitting, Reducer Bushing, 1/2-3/8	18.	07-1716	4	Bolt, Carriage, 3/8-16 x 1
4.	03-1326	1	Pump, Flojet, Water, 2.9gpm	19.	07-1718	4	Washer, Lock, Split, 3/8
5.	03-1709	2	Fitting, Barb, Nylon, 5/8-3/8 MP	20.	07-3279	4	Washer, Flat, 3/8
6.	07-0343	1	Switch, Toggle, 2 Position	21.	07-3638	4	Screw, Cap, 1/4-20 x 1 1/4
7.	07-0411	3	Nozzle, Tee, with Clamp (6/7)	22.	07-3654	4	Nut, Hex, 3/8-16
	07-0411	5	Nozzle, Tee, with Clamp (8)	23.	07-4032	4	Washer, Flat, 1/4
8.	07-412	2	Nozzle, Elbow, with Clamp	24.	07-4038	4	Washer, Lock, Split, 1/4
9.	07-0413	5	Nozzle, Cap, Nylon (6/7)	25.	07-4039	4	Nut, Hex, 1/4-20
	07-0413	7	Nozzle, Cap, Nylon (8)	26.	07-4673	2	U-bolt, 1/4-20 x 1
10.	07-0414	4	Nozzle, Tip, Brass (6/7)	28.	09-0028	7ft	Hose, Heater, 5/8 (6/7)
	07-0414	4	Nozzle, Tip, Brass (8)		09-0028	10ft	Hose, Heater, 5/8 (8)
11.	07-0417	1	Fitting, Barb, Brass, 3/8	29.	09-0056	25ft	Hose, Heater, 3/8 (6)
12.	07-0532	1	Strainer, Hypro, Water		09-0056	26.25ft	Hose, Heater, 3/8 (7)
13.	07-0547	2	Clamp, Spring, 7/8 Hose		09-0056	27.5ft	Hose, Heater, 3/8 (8)
14.	07-0549	10	Clamp, Spring, 5/8 Hose (6/7)	32.	11-6684	1	Tube, 7/8 x 16ga x 72 (6/7)
	07-0549	14	Clamp, Spring, 5/8 Hose (8)		13-2812	1	Tube, 7/8 x 16ga x 92.37 (8)
15.	07-0867	4	Terminal, Butt	33.	13-10076	2	Plate, Mounting, Sprinkler Bar

SPRINKLER

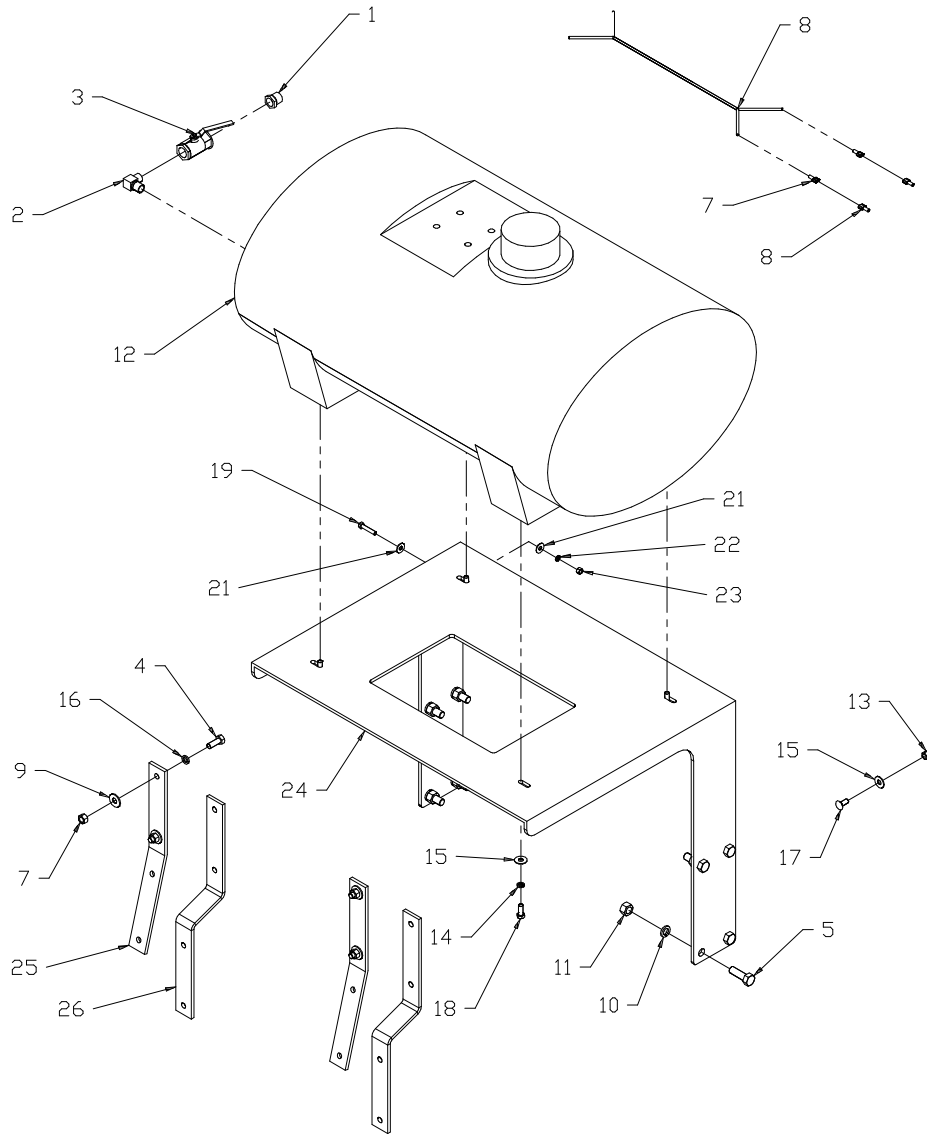

Item	Part	Qty	Description	Item	Part	Qty	Description
1.	03-0819	1	Fitting, Reducer, Bushing, 1/2, 3/8	15.	07-3275	5	Washer, Flat, 5/16
2.	03-1391	1	Fitting, Elbow, 90°, 1/2MP,1/2MP	16.	07-3279	4	Washer, Flat, 3/8
3.	03-1392	1	Valve, Shut-Off, Ball, 1/2	17.	07-3280	1	Bolt, Carriage, 5/16-18 x 3/4
4.	07-0018	4	Screw, Cap, 5/16 x 3/4	18.	07-3436	4	Screw, Cap, 5/16 x 3/4
5.	07-0045	8	Screw, Cap, 1/2-13 x 1 1/2	19.	07-3638	4	Screw, Cap, 1/4 x 1 1/4
6.	07-0812	2	Terminal, QD, FN1/4F, 16-14	20.	07-3654	4	Nut, Hex, 3/8-16
7.	07-0813	2	Terminal, QD, FN1/4M, 16-14	21.	07-4032	4	Washer, Flat, 1/4
8.	07-0917	10ft	Wire, Cord, 16ga	22.	07-4038	4	Washer, Lock, Split, 1/4
9.	07-1718	4	Washer, Lock, Split, 3/8	23.	07-4039	4	Nut, Hex, 1/4-20
10.	07-1762	8	Washer, Lock, 1/2	24.	13-7710	1	Plate, Mounting, Water Tank
11.	07-1764	8	Nut, Hex, 1/2-13	25.	13-7721	2	Plate, Mounting, Spraybar, Round Hood
12.	07-3150	1	Tank, Water, 25 gal	26.	13-16867	2	Plate, Mounting, Spraybar, Flat Hood
13.	07-3270	1	Nut, Hex, 5/16-18, Nylock				
14.	07-3273	4	Washer, Lock, Split, 5/16				



BOLT TORQUE SPECIFICATIONS

GENERAL TORQUE SPECIFICATION TABLES

Use the following charts when determining bolt torque specifications when special torques are not given. Always use grade 5 or better when replacing bolts.



SAE BOLT TORQUE SPECIFICATIONS

NOTE: The following torque values are for use with extreme pressure lubricants, plating or hard washer applications. Increase torque 15% when using hardware that is unplated and either dry or lubricated with engine oil.

Bolt Size		SAE GRADE 5 TORQUE				SAE GRADE 8 TORQUE				Bolt head identification marks as per grade. NOTE: Manufacturing Marks Will Vary
		Pounds Feet		Newton-Meters		Pounds Feet		Newton-Meters		
Inches	Millimeters	UNC	UNF	UNC	UNF	UNC	UNF	UNC	UNF	
1/4	6.35	8	9	11	12	10	13	14	18	<p>GRADE 2</p>  <p>GRADE 5</p>  <p>GRADE 8</p> 
5/16	7.94	14	17	19	23	20	25	27	34	
3/8	9.53	30	36	41	49	38	46	52	62	
7/16	11.11	46	54	62	73	60	71	81	96	
1/2	12.70	68	82	92	111	94	112	127	152	
9/16	14.29	94	112	127	152	136	163	184	221	
5/8	15.88	128	153	174	207	187	224	254	304	
3/4	19.05	230	275	312	373	323	395	438	536	
7/8	22.23	340	408	461	553	510	612	691	830	
1	25.40	493	592	668	803	765	918	1037	1245	
1-1/8	25.58	680	748	922	1014	1088	1224	1475	1660	
1-1/4	31.75	952	1054	1291	1429	1547	1700	2097	2305	
1-3/8	34.93	1241	1428	1683	1936	2023	2312	2743	3135	
1-1/2	38.10	1649	1870	2236	2535	2686	3026	3642	4103	

METRIC BOLT TORQUE SPECIFICATIONS

NOTE: The following torque values are for use with metric hardware that is unplated and either dry or lubricated with engine oil. Reduce torque 15% when using hardware that has extreme pressure lubricants, plating or hard washer applications.

Bolt head identification marks as per grade.		
		
5.6	8.8	10.9

Size of Bolt	Grade No.	Pitch (mm)	Pounds Feet	Newton-Meters	Pitch (mm)	Pounds Feet	Newton-Meters
M6	5.6	1.0	3.6-5.8	4.9-7.9	-	-	-
	8.8		5.8-4	7.9-12.7		-	-
	10.9		7.2-10	9.8-13.6		-	-
M8	5.6	1.25	7.2-14	9.8-19	1.0	12-17	16.3-23
	8.8		17-22	23-29.8		19-27	25.7-36.6
	10.9		20-26	27.1-35.2		22-31	29.8-42
M10	5.6	1.5	20-25	27.1-33.9	1.25	20-29	27.1-39.3
	8.8		34-40	46.1-54.2		35-47	47.4-63.7
	10.9		38-46	51.5-62.3		40-52	54.2-70.5
M12	5.6	1.75	28-34	37.9-46.1	1.25	31-41	42-55.6
	8.8		51-59	69.1-79.9		56-68	75.9-92.1
	10.9		57-66	77.2-89.4		62-75	84-101.6
M14	5.6	2.0	49-56	66.4-75.9	1.5	52-64	70.5-86.7
	8.8		81-93	109.8-126		90-106	122-143.6
	10.9		96-109	130.1-147.7		107-124	145-168
M16	5.6	2.0	67-77	90.8-104.3	1.5	69-83	93.5-112.5
	8.8		116-130	157.2-176.2		120-138	162.6-187
	10.9		129-145	174.8-196.5		140-158	189.7-214.1
M18	5.6	2.0	88-100	119.2-136	1.5	100-117	136-158.5
	8.8		150-168	203.3-227.6		177-199	239.8-269.6
	10.9		175-194	237.1-262.9		202-231	273.7-313
M20	5.6	2.5	108-130	146.3-176.2	1.5	132-150	178.9-203.3
	8.8		186-205	252-277.8		206-242	279.1-327.9
	10.9		213-249	288.6-337.4		246-289	333.3-391.6

GLOSSARY

angle or angle assembly - portion of the sweeper that allows the brush head assembly to angle.

BP - black pipe.

brush head assembly - assembly that includes the core, hood, and brush frame.

brush pattern - area of dirt removed from sweeping surface; with a properly adjusted sweeper; the pattern is the same width for the entire length.

castellated - having battlements like a castle.

caution - indicates a potentially hazardous situation which, if not avoided, may result in minor or moderate injury.

core - weldment that holds brush sections.

danger - indicates an imminently hazardous situation which, if not avoided, will result in death or serious injury.

F - female.

FS - face seal.

front - side that is in front when facing the normal forward direction of travel of the machine.

gpm - gallons per minute.

HP - high pressure.

hood - brush shield.

hydraulic angle kit - means of swinging an assembly hydraulically.

important - used for instructions when machine damage may be involved.

in. - inches.

kph - kilometers per hour.

lb - pounds.

left-hand - side that is on the left when facing the

normal forward direction of travel of the machine.

lift cylinder - means of raising the brush head assembly hydraulically.

lps - liters per second.

M - male.

mm - millimeters.

mph - miles per hour.

manual angle kit - means of swinging the brush head assembly mechanically.

mid pump unit - sweeper in which the pump is mounted on the mid PTO.

mounting assembly - portion of the sweeper that attaches to the prime mover; designed specifically for each prime mover.

NPT - national pipe thread.

note - indicates supplementary information.

OR - o-ring.

psi - pounds per square inch.

PTO - power take off; shaft on the prime mover used to drive attachments.

plate swing - swing assembly that includes a half-moon plate.

power pack - auxiliary hydraulic package used when prime mover hydraulics do not have enough flow available.

prime mover - refers to the tractor, truck, loader or other vehicle to which a sweeper is attached.

qty - quantity.

quick change core - core designed in a way that allows brush sections to be changed without removing hoses from motors.

GLOSSARY

rpm - revolutions per minute.

rear - side that is in rear when facing the normal forward direction of travel of the machine.

rear pump unit - sweeper in which the pump is mounted on a rear PTO.

retainer - removable plate or set of plates that keeps sections on the core.

right-handed - side that is on the right when facing the normal forward direction of travel of the machine.

section - single brush wafer.

section set - replacement brush wafers.

sprinkler system - system that sprays water ahead of the sweeper used to reduce dust.

sprinkler tank - assembly that includes the water reservoir and mounting used in a sprinkler system.

stands - devices designed to keep the components off the ground when the sweeper is dismounted.

swing or swing assembly - portion of the sweeper that allows the brush head assembly to angle.

swing cylinder - means of angling the brush head assembly hydraulically.

tank assembly, hydraulic - assembly that includes the hydraulic reservoir, filter and fittings; may also incorporate valves.

warning - indicates a potentially hazardous situation which, if not avoided, could result in death or serious injury.

weld - weldment.

windrow - pile of debris.

WARRANTY INFORMATION

Limited Warranty

Except for the Excluded Products as described below, all new products are warranted to be free from defects in material and/or workmanship during the Warranty Period, in accordance with and subject to the terms and conditions of this Limited Warranty.

1. Excluded Products. The following products are excluded from this Limited Warranty:

(a) Any cable, part that engages with the ground (i.e. sprockets), digging chain, bearing, teeth, tamping and/or demolition head, blade cutting edge, pilot bit, auger teeth and broom brush that either constitutes or is part of a product.

(b) Any product, merchandise or component that, in the opinion of Paladin Light Construction¹, has been (i) misused; (ii) modified in any unauthorized manner; (iii) altered; (iv) damaged; (v) involved in an accident; or (vi) repaired using parts not obtained through Paladin Light Construction.

2. Warranty Period. The Limited Warranty is provided only to those defects that occur during the Warranty Period, which is the period that begins on the first to occur of: (i) the date of initial purchase by an end-user, (ii) the date the product is first leased or rented, or (iii) the date that is six (6) months after the date of shipment by Paladin Light Construction as evidenced by the invoiced shipment date (the "Commencement Date") and ends on the date that is twelve (12) months after the Commencement Date.

3. Terms and Conditions of Limited Warranty. The following terms and conditions apply to the Limited Warranty hereby provided:

(a) Option to Repair or Replace. Paladin Light Construction shall have the option to repair or replace the product.

(b) Timely Repair and Notice. In order to obtain the Limited Warranty, (i) the product must be repaired within thirty (30) days from the date of failure, and (ii) a claim under the warranty must be submitted to Paladin Light Construction in writing within thirty (30) days from the date of repair.

(c) Return of Defective Part or Product. If requested by Paladin Light Construction, the alleged defective part or product shall be shipped to Paladin Light Construction at its manufacturing facility or other location specified by Paladin Light Construction, with freight PRE-PAID by the claimant, to allow Paladin Light Construction to inspect the part or product.

Claims that fail to comply with any of the above terms and conditions shall be denied.

LIMITATIONS AND EXCLUSIONS.

THIS LIMITED WARRANTY IS IN LIEU OF ALL OTHER WARRANTIES, EXPRESS OR IMPLIED, INCLUDING WITHOUT LIMITATION THE WARRANTIES OF MERCHANTABILITY, FITNESS FOR A PARTICULAR PURPOSE AND ANY WARRANTY BASED ON A COURSE OF DEALING OR USAGE OF TRADE.

IN NO EVENT SHALL PALADIN LIGHT CONSTRUCTION BE LIABLE FOR CONSEQUENTIAL OR SPECIAL DAMAGES.

IN NO EVENT SHALL PALADIN LIGHT CONSTRUCTION BE LIABLE FOR ANY LOSS OR CLAIM IN AN AMOUNT IN EXCESS OF THE PURCHASE PRICE, OR, AT THE OPTION OF PALADIN LIGHT CONSTRUCTION, THE REPAIR OR REPLACEMENT, OF THE PARTICULAR PRODUCT ON WHICH ANY CLAIM OF LOSS OR DAMAGE IS BASED. THIS LIMITATION OF LIABILITY APPLIES IRRESPECTIVE OF WHETHER THE CLAIM IS BASED ON BREACH OF CONTRACT, BREACH OF WARRANTY, NEGLIGENCE OR OTHER CAUSE AND WHETHER THE ALLEGED DEFECT IS DISCOVERABLE OR LATENT.

¹Attachment Technologies Inc., a subsidiary of Paladin Brands Holding, Inc. (PBHI) is referred to herein as Paladin Light Construction.