

X-SERIES EARTH AUGER

OPERATOR'S & PARTS

MANUAL



PALADIN™
LIGHT CONSTRUCTION GROUP

 **BRADCO**

 **FFC**

 **HARLEY**

 **McMILLEN**

 **SWEEPSTER**

The Power of Combined Excellence

MODELS

X950, X1450, X1950, X2450, X1455, X1955

X975, X1475, X1975, X2475, X3575

X1200, X1600, X2200, X3450, & X4450



SERIAL NUMBER: _____

MODEL NUMBER: _____

Manual Number: 22681

Revision 10: June 10, 2010

TABLE OF CONTENTS

AUGER DRIVES

PREFACE	3
SAFETY PRECAUTIONS	
SAFETY STATEMENTS	5
GENERAL SAFETY PRECAUTIONS	5-7
EQUIPMENT SAFETY PRECAUTIONS	8
INSTALLATION	9-11
HYDRAULIC SYSTEM HOOK-UP INSTRUCTIONS	12
OPERATING INSTRUCTIONS	13
MAINTENANCE	
LUBRICATION	14
DAILY INSPECTION	14
PLANETARY GEARBOX	15
STORAGE PROCEDURE	15
PLANETARY GEAR REDUCTION SERVICE PARTS	16
WEAR PARTS	17
TROUBLESHOOTING	18
SPECIFICATIONS	19-20
PARTS	
75 SERIES AUGER DRIVE ASSEMBLIES	21
X3575 AUGER DRIVE ASSEMBLY	22-23
X3450 & X4450 AUGER DRIVE ASSEMBLIES	24
X1455 & X1955 AUGER DRIVE ASSEMBLIES	25
950, 1450, 1950 & 2450 AUGER DRIVE ASSEMBLIES	26
1200, 1600 & 2200 AUGER DRIVE ASSEMBLIES	27
LIMITED WARRANTY	28

**THIS PAGE
IS INTENTIONALLY
BLANK**

PREFACE

GENERAL COMMENTS

Congratulations on the purchase of your new McMillen product! This product was carefully designed and manufactured to give you many years of dependable service. Only minor maintenance (such as cleaning and lubricating) is required to keep it in top working condition. Be sure to observe all maintenance procedures and safety precautions in this manual and on any safety decals located on the product and on any equipment on which the attachment is mounted.

This manual has been designed to help you do a better, safer job. Read this manual carefully and become familiar with its contents.

WARNING!  **Never let anyone operate this unit without reading the "Safety Precautions" and "Operating Instructions" sections of this manual. Always choose hard, level ground to park the vehicle on and set the brake so the unit cannot roll.**

Unless noted otherwise, right and left sides are determined from the operator's control position when facing the attachment.

NOTE: The illustrations and data used in this manual were current (according to the information available to us) at the time of printing, however, we reserve the right to redesign and change the attachment as may be necessary without notification.

BEFORE OPERATION

The primary responsibility for safety with this equipment falls to the operator. Make sure the equipment is operated only by trained individuals that have read and understand this manual. If there is any portion of this manual or function you do not understand, contact your local authorized dealer or the manufacturer.

SAFETY ALERT SYMBOL



This is the "Safety Alert Symbol" used by this industry. This symbol is used to warn of possible injury. Be sure to read all warnings carefully. They are included for your safety and for the safety of others working with you.

SERVICE

When servicing your product, remember to use only manufacturer replacement parts. Substitute parts may not meet the standards required for safe, dependable operation.

To facilitate parts ordering, record the model and serial number of your unit in the space provided on the cover of this manual. This information may be obtained from the identification plate located on the product.

The parts department needs this information to insure that you receive the correct parts for your specific model.

**THIS PAGE
IS INTENTIONALLY
BLANK**

SAFETY STATEMENTS



THIS SYMBOL BY ITSELF OR WITH A WARNING WORD THROUGHOUT THIS MANUAL IS USED TO CALL YOUR ATTENTION TO INSTRUCTIONS INVOLVING YOUR PERSONAL SAFETY OR THE SAFETY OF OTHERS. FAILURE TO FOLLOW THESE INSTRUCTIONS CAN RESULT IN INJURY OR DEATH.



DANGER

THIS SIGNAL WORD IS USED WHERE SERIOUS INJURY OR DEATH WILL RESULT IF THE INSTRUCTIONS ARE NOT FOLLOWED PROPERLY.



WARNING

THIS SIGNAL WORD IS USED WHERE SERIOUS INJURY OR DEATH COULD RESULT IF THE INSTRUCTIONS ARE NOT FOLLOWED PROPERLY.



CAUTION

THIS SIGNAL WORD IS USED WHERE MINOR INJURY COULD RESULT IF THE INSTRUCTIONS ARE NOT FOLLOWED PROPERLY.

NOTICE

NOTICE INDICATES A PROPERTY DAMAGE MESSAGE.

GENERAL SAFETY PRECAUTIONS

WARNING!

READ MANUAL PRIOR TO INSTALLATION



Improper installation, operation, or maintenance of this equipment could result in serious injury or death. Operators and maintenance personnel should read this manual, as well as all manuals related to this equipment and the prime mover thoroughly before beginning installation, operation, or maintenance. **FOLLOW ALL SAFETY INSTRUCTIONS IN THIS MANUAL AND THE PRIME MOVER'S MANUAL(S).**



READ AND UNDERSTAND ALL SAFETY STATEMENTS

Read all safety decals and safety statements in all manuals prior to operating or working on this equipment. Know and obey all OSHA regulations, local laws, and other professional guidelines for your operation. Know and follow good work practices when assembling, maintaining, repairing, mounting, removing, or operating this equipment.



KNOW YOUR EQUIPMENT

Know your equipment's capabilities, dimensions, and operations before operating. Visually inspect your equipment before you start, and never operate equipment that is not in proper working order with all safety devices intact. Check all hardware to ensure it is tight. Make certain that all locking pins, latches, and connection devices are properly installed and secured. Remove and replace any damaged, fatigued, or excessively worn parts. Make certain all safety decals are in place and are legible. Keep decals clean, and replace them if they become worn or hard to read.

GENERAL SAFETY PRECAUTIONS

WARNING!



PROTECT AGAINST FLYING DEBRIS

Always wear proper safety glasses, goggles, or a face shield when driving pins in or out, or when any operation causes dust, flying debris, or any other hazardous material.

WARNING!



LOWER OR SUPPORT RAISED EQUIPMENT

Do not work under raised booms without supporting them. Do not use support material made of concrete blocks, logs, buckets, barrels, or any other material that could suddenly collapse or shift positions. Make sure support material is solid, not decayed, warped, twisted, or tapered. Lower booms to ground level or on blocks. Lower booms and attachments to the ground before leaving the cab or operator's station.

WARNING!



USE CARE WITH HYDRAULIC FLUID PRESSURE

Hydraulic fluid under pressure can penetrate the skin and cause serious injury or death. Hydraulic leaks under pressure may not be visible. Before connecting or disconnecting hydraulic hoses, read your prime mover's operator's manual for detailed instructions on connecting and disconnecting hydraulic hoses or fittings.

- Keep unprotected body parts, such as face, eyes, and arms as far away as possible from a suspected leak. Flesh injected with hydraulic fluid may develop gangrene or other permanent disabilities.
- If injured by injected fluid, see a doctor at once. If your doctor is not familiar with this type of injury, ask him or her to research it immediately to determine proper treatment.
- Wear safety glasses, protective clothing, and use a piece of cardboard or wood when searching for hydraulic leaks. **DO NOT USE YOUR HANDS! SEE ILLUSTRATION.**

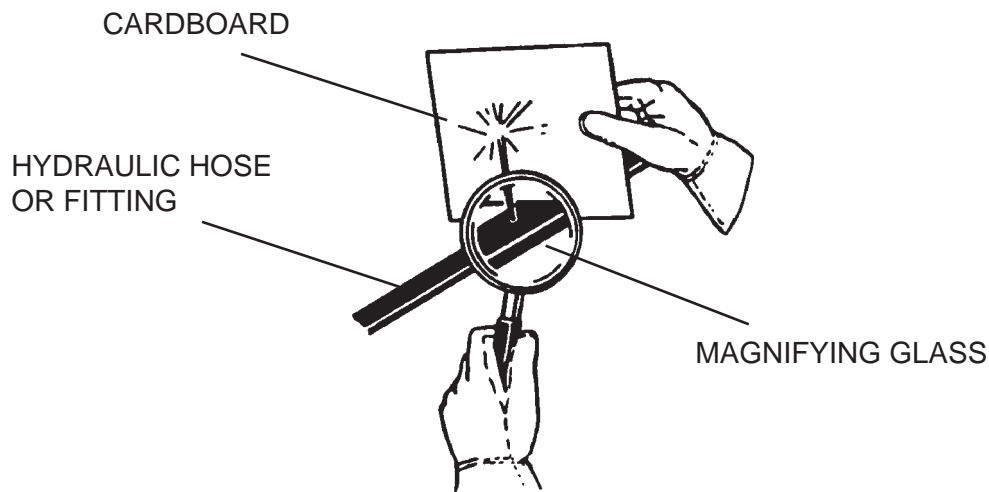

GENERAL SAFETY PRECAUTIONS

WARNING!



DO NOT MODIFY MACHINE OR ATTACHMENTS

Modifications may weaken the integrity of the attachment and may impair the function, safety, life, and performance of the attachment. When making repairs, use only the manufacturer's genuine parts, following authorized instructions. Other parts may be substandard in fit and quality. Never modify any ROPS (Roll Over Protection Structure) or FOPS (Falling Object Protective Structure) equipment or device. Any modifications must be authorized in writing by the manufacturer.

WARNING!



SAFELY MAINTAIN AND REPAIR EQUIPMENT

- Do not wear loose clothing or any accessories that can catch in moving parts. If you have long hair, cover or secure it so that it does not become entangled in the equipment.
- Work on a level surface in a well-lit area.
- Use properly grounded electrical outlets and tools.
- Use the correct tools for the job at hand. Make sure they are in good condition for the task required.
- Wear the protective equipment specified by the tool manufacturer.



SAFELY OPERATE EQUIPMENT

Do not operate equipment until you are completely trained by a qualified operator in how to use the controls, know its capabilities, dimensions, and all safety requirements. See your machine's manual for these instructions.

- Keep all step plates, grab bars, pedals, and controls free of dirt, grease, debris, and oil.
- Never allow anyone to be around the equipment when it is operating.
- Do not allow riders on the attachment or the prime mover.
- Do not operate the equipment from anywhere other than the correct operator's position.
- Never leave equipment unattended with the engine running, or with this attachment in a raised position.
- Do not alter or remove any safety feature from the prime mover or this attachment.
- Know your work site safety rules as well as traffic rules and flow. When in doubt on any safety issue, contact your supervisor or safety coordinator for an explanation.

EQUIPMENT SAFETY PRECAUTIONS

WARNING! KNOW WHERE UTILITIES ARE



Observe overhead electrical and other utility lines. Be sure equipment will clear them. When digging, call your local utilities for location of buried utility lines, gas, water, and sewer, as well as any other hazard you may encounter.



OPERATING THE PRIME MOVER

Avoid steep hillside operation, which could cause the prime mover to overturn. Consult your prime mover operator's and safety manuals for maximum incline allowable.



EXPOSURE TO RESPIRABLE CRYSTALLINE SILICA DUST ALONG WITH OTHER HAZARDOUS DUSTS MAY CAUSE SERIOUS OR FATAL RESPIRATORY DISEASE.

It is recommended to use dust suppression, dust collection and if necessary, personal protective equipment during the operation of any attachment that may cause high levels of dust.



WORKING WITH THE AUGER

- All bystanders should be kept a minimum of 10 feet (3 meters) away from the working area of the earth auger.
- An operator must not use drugs or alcohol, which can change his or her alertness or coordination. An operator taking prescription or over-the-counter drugs should seek medical advice on whether or not he or she can safely operate equipment.
- Before exiting the prime mover, lower the earth auger to the ground, turn off the prime mover's engine, and lock the prime mover's brakes.
- Flow and pressure gauges, fittings, and hoses must have a continuous operating pressure rating of at least 25% higher than highest pressures of the system.



TRANSPORTING THE AUGER

- Travel only with the earth auger in a safe transport position to prevent uncontrolled movement. Drive slowly over rough ground and on slopes.
- Tether the earth auger with a chain, if necessary, to prevent uncontrolled swinging of the auger when moving from hole to hole.
- Remove the earth auger from the prime mover before transporting to and from the job site.



MAINTAINING THE AUGER

- Never adjust a relief valve for pressure higher than recommended by the prime mover manufacturer.
- Never perform any work on an earth auger unless you are authorized and qualified to do so. Always read the operator service manual(s) before any repair is made. After completing maintenance or repair, check for correct functioning of the earth auger. If not functioning properly, always tag "DO NOT OPERATE" until all problems are corrected.
- Worn, damaged, or illegible safety decals must be replaced. New safety decals can be ordered from McMillen®.

INSTALLATION INSTRUCTIONS

GENERAL INFORMATION

Find the mounting kit diagram and parts list for the kit you have received. Study the diagram and familiarize yourself with the names of the various parts. This knowledge will assist you in understanding these instructions.

Read these instructions carefully before attempting to mount the auger.

READ AND UNDERSTAND ALL SAFETY INFORMATION PRIOR TO MOUNTING YOUR AUGER.

QUICK ATTACH MOUNTING ASSEMBLIES

(Includes some Excavator Mounts, Telehandler Mounts and all Skid Steer & Wheel Loader Mounts.)

1. Remove the bucket or other attachment from the prime mover quick attach mechanism.
2. Attach the quick attach mounting bracket to the prime mover quick attach mechanism, as per manufacturer's recommendations.
3. Attach the swivel (#21694) to the quick attach mounting bracket with pin (#22255) provided. Secure the pin in place with klik pins (#21169).
4. If your mounting bracket is designed for the installation of a cradle, bolt the cradle to the bracket using the .50" UNC X 2.00" capscrews, lock washers and hex nuts provided.
5. Install the drive unit to the swivel using the pin provided with the drive unit assembly.
6. Install the auger to the drive unit with the bolt and nut provided with the drive unit assembly.
7. Refer to the **"HYDRAULIC SYSTEM HOOK-UP"** section in this manual for hydraulic connection instructions and recommendations.

BACKHOE AND EXCAVATOR "PENDULUM" MOUNTING ASSEMBLIES

1. Remove the bucket from the dipper arm and curl cylinder pin connections. The dipper arm pin will be used to attach auger pendulum mounting to the dipper arm. Curl cylinder pin will not be required for auger installation.
2. If using a universal adjustable width pendulum mounting assembly: Space the two backhoe adapter ears to the same width as the dipper arm and secure to the base using the .50" hardware provided. After determining the correct width, the backhoe adapter ears must be welded to the base.

INSTALLATION INSTRUCTIONS

3. Attach the pendulum mounting (all types) to the dipper using the dipper arm pin removed from the bucket in Step #1. Secure the bucket pin as per prime mover manufacturer's recommendation.
4. Install the auger drive unit to pendulum mount with pivot pin provided with the drive unit assembly.
5. Install the auger to the drive unit with the bolt and nut provided with the drive unit assembly.
6. Refer to the **"HYDRAULIC SYSTEM HOOK-UP"** section in this manual for hydraulic connection instructions and recommendations.

BACKHOE AND EXCAVATOR "PIN GRABBER" MOUNTING ASSEMBLIES

1. Remove the bucket from the dipper arm and curl cylinder pin connections.
2. Attach the pin grabber mounting (all types) to the dipper and curl cylinder using the pivot pins and cotter pins provided.
3. Attach the swivel (#21694) to the pin grabber mounting bracket with pivot pin provided. Secure the pin in place with klik pins (#21169).

NOTE: Some assemblies require the installation of step bushings on each side of the swivel when supplied with a pivot pin longer than the standard #22255 (1.25" diameter by 6.00" effective length) pivot pin.

4. If your mounting bracket is designed for the installation of a cradle, bolt the cradle to the bracket using the .50" UNC X 2.00" capscrews, lock washers and hex nuts provided.
5. Install the drive unit to the swivel using the pin provided with the drive unit assembly.
6. Install the auger to the drive unit with the bolt and nut provided with the drive unit assembly.
7. Refer to the **"HYDRAULIC SYSTEM HOOK-UP"** section in this manual for hydraulic connection instructions and recommendations.

INSTALLATION INSTRUCTIONS

UNIVERSAL FRONT END LOADER MOUNTING ASSEMBLY

1. The universal front end loader mounting assembly (#21235) can be used to adapt your McMillen Earth Auger to the side of the loader arm, lip of a bucket, or fork lift forks. **DO NOT USE ON SKID -STEER LOADERS.**
2. Place loader bracket clamp plate (#21449) on the inside of the loader arm, top of the bucket lip or top of fork lift fork.

NOTE: For mounting on lip of bucket you will need to drill two 7/16" diameter holes through the bucket.

3. Place the loader bracket #21628 on the opposite side of clamp plate and secure with the four .44" bolts #1080 and hex nuts #1227 provided.
4. Attach the swivel (#21694) to the loader mounting bracket with pivot pin #22255 provided. Secure the pin in place with klik pins (#21169).
5. Install the drive unit to the swivel using the pin provided with the drive unit assembly.
6. Install the auger to the drive unit with the bolt and nut provided with the drive unit assembly.
7. Refer to the **"HYDRAULIC SYSTEM HOOK-UP"** section in this manual for hydraulic connection instructions and recommendations.

WELD-ON EXCAVATOR MOUNTING

McMillen offers a blank weld on plate with mounting ears and swivel for welding onto your own excavator mounting bracket.

After securely welding the plate onto your bracket:

1. Attach the swivel (#21694) to the mounting plate with pivot pin #22255 provided. Secure the pin in place with klik pins #21169.
2. Install the drive unit to the swivel using the pin provided with the drive unit assembly.
3. Install the auger to the drive unit with the bolt and nut provided with the drive unit assembly.
4. Refer to the **"HYDRAULIC SYSTEM HOOK-UP"** section in this manual for hydraulic connection instructions and recommendations.

HYDRAULIC SYSTEM HOOK-UP INSTRUCTIONS

GENERAL INFORMATION

Once the installation instructions are complete, you are now ready to make the hydraulic connections necessary to operate your earth drill.

READ AND UNDERSTAND SAFETY INFORMATION PRIOR TO MAKING HYDRAULIC CONNECTIONS.

Your equipment dealer is in the best position to advise you as to where the best place on your machine is to make the hydraulic connections to power your earth drill drive unit. The list below shows the most common places to “tap” into the hydraulic system on various types of machines.

- **SKID STEER LOADERS** - Auxiliary hydraulic outlets.
- **BACKHOES & EXCAVATORS** - Auxiliary hydraulic outlets or bucket curl cylinder circuit.
- **WHEEL LOADERS & TRACTOR LOADERS** - Auxiliary hydraulic outlets or bucket tilt (dump) cylinder circuit.

Determine the length of hydraulic hoses required to plumb drive unit into the place on your machine where you will be “tapping” into the hydraulics. Be sure the two hydraulic hoses are long enough to perform at the full range of the earth drill’s operating capacity. A case drain line may also be required to operate your earth drill.

- **Models 975, 1475, 1975, 2475 and 3575** require two 1/2”(12.7mm) or 3/4” (19mm) ID hydraulic hoses with #10 JIC Female fittings on one end of each hose to connect hoses to drive unit fittings.
- **Models 3450 and 4450 ONLY.** These models are designed for maximum back pressure of 400 psi (28 kg/cm²) and require two 3/4” (19mm) hydraulic hoses with #12 JIC Female fittings on one end of each hose to connect hoses to drive unit fittings.

For back pressures exceeding 400 psi (28 kg/cm²): A **Drain Line Kit** (Part #21218) is available for models 3450 and 4450 when back pressures exceed 400 psi. **To order**, contact your local dealer.

NOTE: Fittings on the other end of each hydraulic hose should match the threads on the hydraulic quick couplers to be used.

WARNING! HOSES AND FITTINGS MUST HAVE A CONTINUOUS OPERATING PRESSURE RATING OF AT LEAST 25% HIGHER THAN THE HIGHEST PRESSURES OF THE SYSTEM YOU ARE “TAPPING” INTO.



Once all of the hydraulic connections have been made and checked for leaks, you are now ready to operate your earth drill. **READ AND UNDERSTAND OPERATING INSTRUCTIONS AND SAFETY INFORMATION PRIOR TO OPERATING YOUR EARTH DRILL.**

OPERATING INSTRUCTIONS

1. After all installation instructions have been completed, safety information read and understood, and the rest of this operator's manual has been reviewed, your McMillen Hydraulic Earth Drill is now ready for use.
2. With the auger raised off the ground and the vehicle engine set at a low RPM, activate the earth drill control valve to determine which position the control valve lever must be in to turn auger in a forward (clockwise) rotation. This is the "digging" position.
3. Before beginning to dig, experiment with auger speed to determine a suitable auger RPM. Generally in light and sandy soil a high RPM is desirable. In hard, rocky, or frozen soils a slower RPM is desirable. To increase auger RPM, increase vehicle engine RPM. To decrease auger RPM, decrease vehicle engine RPM.
4. Return earth drill control valve to neutral position to stop the auger. Lower the auger to the ground so that only the center point penetrates the ground about 2" (51mm).
5. Activate the earth drill control valve so auger is turning in a forward (clockwise) rotation. Use only enough down pressure to assure positive penetration of auger into the ground. Ease up on down pressure if auger rotation slows down drastically or stalls.

NOTE: Excessive down pressure will cause the auger to stall frequently.

6. When auger has penetrated the ground about 24" (610mm), raise the auger from the hole to clean the dirt out. Repeat this procedure until the desired hole depth is obtained.
7. Once the required hole depth is reached, allow the auger to turn a few seconds at this depth to clean the hole.
8. Return the earth drill control valve to the neutral position to stop the rotation of the auger. Raise the auger out of the hole, move away from the hole, then activate the earth drill control valve to spin the loose soil off of the augers.

NOTE: Do not reverse the auger rotation to remove from the hole as loose soil on the auger flights will fall back into the hole.

9. If necessary, repeat steps 7 & 8 to obtain a cleaner hole.
10. In some soil conditions or when excessive down pressure is applied, auger may "screw" itself into the ground and become stuck causing earth drill to stall. If this happens, reverse the auger rotation (counter-clockwise) by moving the control valve lever to the reverse position and slowly raise the auger. Once unstuck, return the control valve lever to the forward rotation position and continue digging.
11. If the auger becomes lodged under rocks, roots, or other large obstructions, do not attempt to raise the auger out of the ground. See step 10 for proper procedure to relieve the auger.
12. Avoid excessive side loading to earth drill which can cause drive unit or auger damage.
13. Keep auger teeth and points in good condition. Check frequently and always keep spares on hand so they can be replaced as wear is detected to avoid damage to tooth holders and auger flighting.

WARNING: To prevent possible injury or death, keep all bystanders 10 feet or more away from rotating auger. Take extra precautions when digging in locations where any type of landscape fabric may be present.



M-1656 11-12-07

MAINTENANCE

GENERAL INFORMATION

Your McMillen earth drill was designed to be virtually maintenance free. Very little effort is needed to keep it in top working condition. It is however, important to follow these procedures to get full performance and longevity out of the unit.

LUBRICATION

Change planetary gear reduction oil with API-GL-5, 80W or 90W lubricant after the first 50 hours of operation and then every 1000 hours or 12 months, whichever comes first.

DAILY INSPECTION

- Check hydraulic oil for cleanliness and contamination. Change if necessary.
- Check hydraulic hoses for damage, leaking and/or signs of excessive heat. Replace if necessary.
- Check auger point for excessive wear or loose fit. Replace if necessary.
- Check auger teeth for excessive wear or loose fit. Replace if necessary.
- Check output shaft for excessive wear, damage or leakage. Replace if necessary.
- Check all bolts and pivot pins for damage, breaks or wear. Replace if necessary.

CAUTION!  **EXCESSIVE VENTING OF LUBRICANT FROM PLANETARY MAY INDICATE THAT THE MOTOR SHAFT SEAL IS LEAKING. UNIT SHOULD BE REPAIRED IMMEDIATELY.**

PLANETARY SHAFT SEAL REPLACEMENT IS THE ONLY PLANETARY REPAIR THAT CAN BE MADE WHILE THE UNIT IS UNDER WARRANTY. (SEE PARTS PAGES FOR PLANETARY SEAL NUMBER.)

MOTOR SHAFT SEAL REPLACEMENT IS THE ONLY HYDRAULIC MOTOR REPAIR THAT CAN BE MADE WHILE THE UNIT IS UNDER WARRANTY. (SEE PARTS PAGES FOR MOTOR SEAL NUMBER.)

MAINTENANCE

PLANETARY GEARBOX

Change gear box oil using API-GL-5, 80W or 90W lubricant after the first 50 hours of operation and then every 1200 hours or 12 months, whichever comes first. Check oil level frequently to maintain proper lubrication.

CHECKING PLANETARY LUBRICANT

1. Place the planetary in a horizontal position.
2. Remove fill plug.
3. Check the lubricant level. Gear lub level should be visible through the fill plug hole.
4. To Fill: Tilt the planetary slightly (maximum 15°) and add lubricant up to fill plug location. With the planetary in this position, lubricant should cover the internal gear and be visible through the fill hole when in a horizontal position.

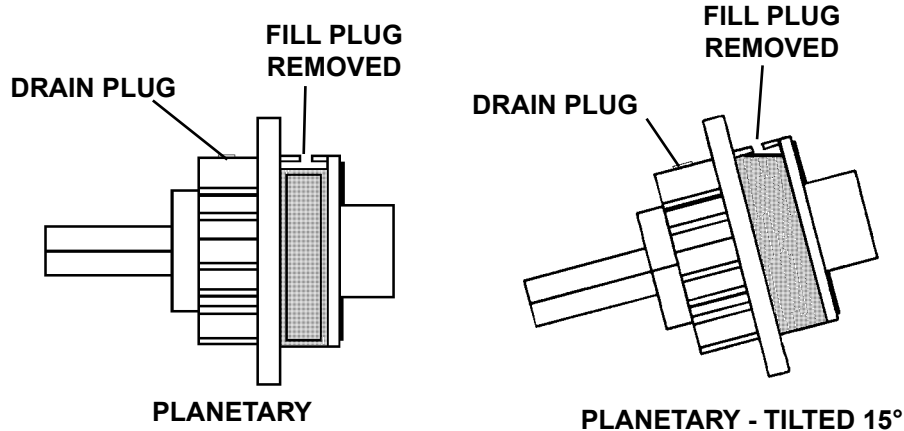

STORAGE PROCEDURE

1. Check to ensure that hydraulic motor and hoses are full of clean oil.
2. Be sure planetary is full of clean lubricant.
3. Clean unit thoroughly, removing all mud, dirt, and grease.
4. Tighten all loose hardware.
5. Touch up unpainted and exposed areas with paint to prevent rust.
6. Coat the drive unit output shaft, inside of auger collar, variable auger extension shaft and inside of auger extension collar to prevent rust and reduce wear.
7. Store the unit in a dry and protected place. Leaving the auger and drive unit outside, exposed to the elements, will materially shorten its life.
8. Inspect the unit for visible signs of wear, breakage or damage. Order any parts required and make necessary repairs to avoid delays when starting next season.
9. Replace decals if damaged or in unreadable condition.

MAINTENANCE

PLANETARY GEAR REDUCTION FOR X975, X1475, X1975, X2475 & X3575 AUGER DRIVES
ASSEMBLIES #23525, #23526 & #23527

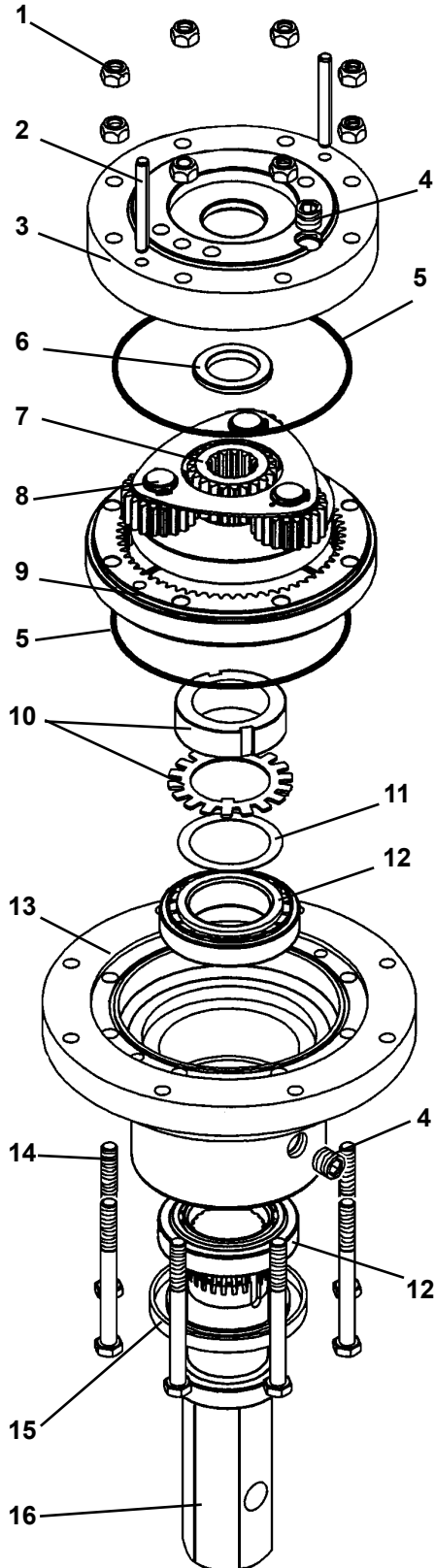

WARRANTY NOTICE:
ANY ATTEMPT TO DISASSEMBLE OR
MAKE FIELD REPAIRS TO THE
PLANETARY WILL VOID WARRANTY.
CONTACT YOUR DEALER/DISTRIBUTOR.

ITEM REQ'D PART NO. DESCRIPTION

1	8	31685	M10 Nylock Nut
2	2	112355	Spring Pin
3	1	31672	Input Housing
4	2	15074	Plug
5	2	45951	O-Ring
6	1	31673	Thrust Washer
7	1	15336	Sun Gear
8	1	15335	Gearset
9	1	31675	Ring Gear
10	1	101526	Lock Nut with Locking Tab
11	1	10171	Thrust Washer
12	2	31681	Tapered Roller Bearing / Race
13	1	15075	Output Housing
14	8	31671	M10 X 110mm Hex Capscrew - G8.8
15	1	33510	Seal
16	1	15072	2" Hex Shaft - 23 Spline
	1	15070	2.00" Round Shaft - 23 Spline
	1	15071	2.56" Round Shaft - 23 Sprine

HDC STYLE AUGER WEAR PARTS LIST

AUGER DIA.	8"	9"	10"	12"	15"	16"	18"	20"	24"	30"	36"	42"	48"
Part #	152mm	203mm	229mm	254mm	305mm	381mm	406mm	457mm	610mm	762mm	914mm	1067mm	1219mm
Qty	2	2	2	2	2	2	2	2	2	2	2	2	2
Description(Standard Components)	Hardened Drive-In Gage Tooth	Hardened Drive-In Gage Tooth	Hardened Drive-In Gage Tooth	Hardened Drive-In Gage Tooth	Hardened Drive-In Gage Tooth	Hardened Drive-In Gage Tooth	Hardened Drive-In Gage Tooth	Hardened Drive-In Gage Tooth	Hardened Drive-In Gage Tooth	Hardened Drive-In Gage Tooth	Hardened Drive-In Gage Tooth	Hardened Drive-In Gage Tooth	Hardened Drive-In Gage Tooth
	2	2	2	2	2	2	2	2	2	2	2	2	2
	-	2	2	2	4	4	4	4	6	8	10	14	18
	1	1	1	1	1	1	1	1	1	1	1	1	1
	2	4	4	4	6	6	6	6	8	10	12	16	20

HDF STYLE AUGER WEAR PARTS LIST

AUGER DIA.	6"	8"	9"	10"	12"	15"	16"	18"	20"	24"	30"	36"
Part #	102mm	152mm	203mm	229mm	254mm	305mm	381mm	406mm	457mm	610mm	762mm	914mm
Qty	-	2	2	2	2	2	2	2	2	2	2	2
Description(Standard Components)	Hardened Bolt-on Gage Tooth	Hardened Bolt-on Gage Tooth	Hardened Bolt-on Gage Tooth	Hardened Bolt-on Gage Tooth	Hardened Bolt-on Gage Tooth	Hardened Bolt-on Gage Tooth	Hardened Bolt-on Gage Tooth	Hardened Bolt-on Gage Tooth	Hardened Bolt-on Gage Tooth	Hardened Bolt-on Gage Tooth	Hardened Bolt-on Gage Tooth	Hardened Bolt-on Gage Tooth
	-	-	-	1	1	1	1	1	1	1	1	1
	-	1	1	1	1	1	1	1	1	1	1	1
	1	-	-	-	-	-	-	-	-	-	-	-
	-	2	2	3	3	4	5	5	6	6	8	9
	-	2	2	3	3	4	5	5	6	6	8	9
	-	2	2	3	3	4	5	5	6	6	8	9

HTF STYLE AUGER WEAR PARTS LIST

AUGER DIA.	18"	24"	30"	36"	42"	48"
Part #	457mm	610mm	762mm	914mm	1067mm	1219mm
Qty	4	4	4	4	4	4
Description(Standard Components)	Hardened Bolt-on Gage Tooth	Hardened Bolt-on Gage Tooth	Hardened Bolt-on Gage Tooth	Hardened Bolt-on Gage Tooth	Hardened Bolt-on Gage Tooth	Hardened Bolt-on Gage Tooth
	3	6	7	9	11	13
	1	1	1	1	1	1
	7	10	11	13	15	17
	7	10	11	13	15	17

OPTIONAL HARDFACED & CARBIDE WEAR COMPONENTS

Part #	Description
22170	Hardfaced Wisdom Tooth
22186	Carbide Wisdom Tooth
22181	Hardened Chisel Tooth
22183	Hardfaced Chisel Tooth
22182	Carbide Chisel Tooth
22190	3.50" Hardened Fishtail Point (Male Hub)
22192	3.50" Hardfaced Fishtail Point (Male Hub)
22191	3.50" Carbide Fishtail Point (Male Hub)
22193	3.50" Hardfaced /Carbide Fishtail Point (Male Hub)
22003	4.50" Hardened Fishtail Point (Female)
22004	4.50" Hardfaced Fishtail Point (Female)
22005	4.50" Hardfaced /Carbide Fishtail Point (Female)
22171	3.50" Hardened Fishtail Point (Female)
22172	3.50" Carbide Fishtail Point (Female)
22173	3.50" Hardfaced Fishtail Point (Female)
22174	3.50" Hardfaced /Carbide Fishtail Point (Female)

17 **NOTE:** Contact your equipment dealer for wear components not listed above. If you have any special auger needs or applications, feel free to contact McMillen.

IMPORTANT: McMillen does not recommend augers exceeding 36" diameter for C-Series Drive Units.

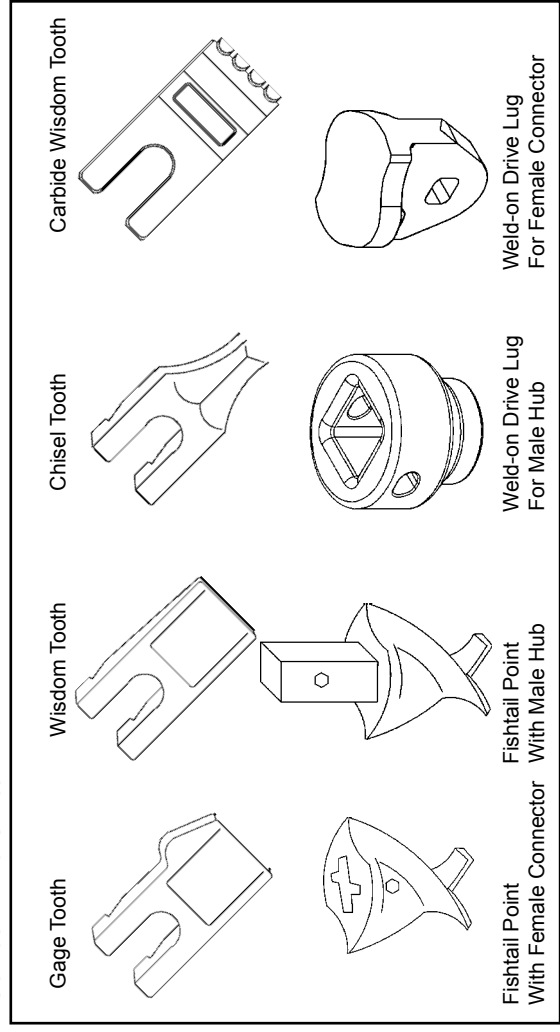

TROUBLESHOOTING

PROBLEM	POSSIBLE CAUSE	SOLUTION
Slow Speed	Low Flow	Check with flow meter. If low investigate cause.
	Line restrictions	Clear lines
	Fittings or connections too small	Replace with proper sizes.
	Oil filter dirty	Replace
	Hydraulic pump worn or damaged	See Dealer for repair
Insufficient Digging Power	Worn teeth or point	Replace
	Low system Pressure (PSI)	Check with pressure gauge. If low, investigate cause.
	Relief Valve damaged or setting wrong	Adjust or replace as required.
	Excessive load	Reduce load to within machine specifications.
Reverse Direction	Hoses reversed	Re-install hoses correctly.
Excessive Oil Heating	Line restrictions	Clear lines
	Fluid dirty	Replace hydraulic fluid and filter.
	Insufficient quantity of hydraulic fluid	Fill reservoir to proper level. increase reservoir storage capacity.
Oil Leaks	Hoses loose or damaged	Tighten or replace
	Fittings loose or damaged	Tighten or replace
	Hydraulic motor seals worn or damaged	See Dealer for repair.

SPECIFICATIONS

MODEL 950

Maximum Auger Diameter: 24"(610mm)
 Minimum Hydraulic Flow: 6gpm(30lpm)
 Maximum Hydraulic Flow: 15gpm(57lpm)
 Maximum Continuous Operating PSI: 3000 psi (211 kg/cm²)
 Maximum Back Pressure: 1500 psi (105 kg/cm²)
 Output shaft Options: 2" (51mm) Round
 2-9/16" (65mm) Round
 2" (51mm)Hexagon

OUTPUT SPEED			OUTPUT TORQUE		
FLOW	SPEED	PRESSURE	TORQUE	TORQUE	
GPM (LPM)	= RPM	PSI (kg/cm ²)	= Lb•Ft (N•m)		
6 (23)	= 38	2000 (141)	= 955 (1295)		
8 (30)	= 51	2500 (176)	= 1194 (1619)		
10 (38)	= 64	3000 (211)	= 1433 (1942)		
12 (45)	= 77				
15 (57)	= 96				

MODEL 1450

Maximum Auger Diameter: 30"(762mm)
 Minimum Hydraulic Flow: 10gpm(38lpm)
 Maximum Hydraulic Flow: 25gpm(95lpm)
 Maximum Continuous Operating PSI: 3000 psi (211 kg/cm²)
 Maximum Back Pressure: 1500 psi (105 kg/cm²)
 Output shaft Options: 2" (51mm) Round
 2-9/16" (65mm) Round
 2" (51mm)Hexagon

OUTPUT SPEED			OUTPUT TORQUE		
FLOW	SPEED	PRESSURE	TORQUE	TORQUE	
GPM (LPM)	= RPM	PSI (kg/cm ²)	= Lb•Ft (N•m)		
10 (38)	= 41	2000 (141)	= 1482 (2009)		
12 (45)	= 49	2500 (176)	= 1853 (2512)		
14 (53)	= 58	3000 (211)	= 2224 (3015)		
16 (61)	= 66				
18 (68)	= 74				
20 (76)	= 83				
25 (95)	= 104				

MODEL 1950

Maximum Auger Diameter: 36"(914mm)
 Minimum Hydraulic Flow: 15gpm(57lpm)
 Maximum Hydraulic Flow: 30gpm(114lpm)
 Maximum Continuous Operating PSI: 3000 psi (211 kg/cm²)
 Maximum Back Pressure: 1500 psi (105 kg/cm²)
 Output shaft Options: 2" (51mm) Round
 2-9/16" (65mm) Round
 2" (51mm)Hexagon

OUTPUT SPEED			OUTPUT TORQUE		
FLOW	SPEED	PRESSURE	TORQUE	TORQUE	
GPM (LPM)	= RPM	PSI (kg/cm ²)	= Lb•Ft (N•m)		
15 (57)	= 49	2000 (141)	= 1861 (2523)		
18 (68)	= 59	2500 (176)	= 2326 (3153)		
20 (76)	= 66	3000 (211)	= 2791 (3784)		
22 (83)	= 72				
24 (91)	= 79				
26 (98)	= 86				
28 (106)	= 92				
30 (114)	= 98				

MODEL 2450

Maximum Auger Diameter: 36"(914mm)
 Minimum Hydraulic Flow: 20gpm(76lpm)
 Maximum Hydraulic Flow: 35gpm(132lpm)
 Maximum Continuous Operating PSI: 3000 psi (211 kg/cm²)
 Maximum Back Pressure: 1500 psi (105 kg/cm²)
 Output shaft Options: 2" (51mm) Round
 2-9/16" (65mm) Round
 2" (51mm)Hexagon

OUTPUT SPEED			OUTPUT TORQUE		
FLOW	SPEED	PRESSURE	TORQUE	TORQUE	
GPM (LPM)	= RPM	PSI (kg/cm ²)	= Lb•Ft (N•m)		
20 (76)	= 51	2000 (141)	= 2388 (3237)		
22 (83)	= 56	2500 (176)	= 2985 (4047)		
24 (91)	= 62	3000 (211)	= 3582 (4856)		
26 (98)	= 67				
28 (106)	= 72				
30 (114)	= 77				
35 (132)	= 90				

MODEL 3450

Maximum Auger Diameter: 36"(914mm)
 Minimum Hydraulic Flow: 25gpm(95lpm)
 Maximum Hydraulic Flow: 45gpm(170lpm)
 Maximum Continuous Operating PSI: 3000 psi (211 kg/cm²)
 Maximum Back Pressure: 400 psi (28 kg/cm²)
 Output shaft Options: 2" (51mm)Hexagon

OUTPUT SPEED			OUTPUT TORQUE		
FLOW	SPEED	PRESSURE	TORQUE	TORQUE	
GPM (LPM)	= RPM	PSI (kg/cm ²)	= Lb•Ft (N•m)		
25 (95)	= 56	2000 (141)	= 2727 (3697)		
30 (114)	= 67	2500 (176)	= 3409 (4621)		
35 (132)	= 79	3000 (211)	= 4091 (5546)		
40 (151)	= 90				
45 (170)	= 101				

MODEL 4450

Maximum Auger Diameter: 48"(914mm)
 Minimum Hydraulic Flow: 30gpm(114lpm)
 Maximum Hydraulic Flow: 60gpm(227lpm)
 Maximum Continuous Operating PSI: 3000 psi (211 kg/cm²)
 Maximum Back Pressure: 400 psi (28 kg/cm²)
 Output shaft Options: 2" (51mm)Hexagon

OUTPUT SPEED			OUTPUT TORQUE		
FLOW	SPEED	PRESSURE	TORQUE	TORQUE	
GPM (LPM)	= RPM	PSI (kg/cm ²)	= Lb•Ft (N•m)		
30 (114)	= 52	2000 (141)	= 3504 (4750)		
35 (132)	= 61	2500 (176)	= 4380 (5938)		
40 (151)	= 70	3000 (211)	= 5256 (7125)		
45 (170)	= 79				
50 (189)	= 87				
55 (208)	= 96				
60 (227)	= 105				

Output speed and torque specifications are based on theoretical values and are provided for comparative purposes only.

McMillen is continually striving to improve its products. Therefore, we reserve the right to make changes to our products or specifications at any time without notice or obligation.

SPECIFICATIONS

MODEL 975

Maximum Auger Diameter:	24"(610mm)
Minimum Hydraulic Flow:	6gpm(30lpm)
Maximum Hydraulic Flow:	15gpm(57lpm)
Maximum Continuous Operating PSI:	3000 psi (211 kg/cm ²)
Maximum Back Pressure	1500 psi (105 kg/cm ²)
Output shaft Options:	2" (51mm) Round 2-9/16" (65mm) Round 2" (51mm)Hexagon

OUTPUT SPEED		OUTPUT TORQUE	
FLOW	SPEED	PRESSURE	TORQUE
GPM (LPM)	= RPM	PSI (kg/cm ²)	= Lb•Ft (N•m)
6 (23)	= 36	2000 (141)	= 1000 (1356)
8 (30)	= 47	2500 (176)	= 1277 (1731)
10 (38)	= 60	3000 (211)	= 1500 (2034)
12 (45)	= 71		
15 (57)	= 89		

MODEL 1455 & 1475

Maximum Auger Diameter:	30"(762mm)
Minimum Hydraulic Flow:	10gpm(38lpm)
Maximum Hydraulic Flow:	25gpm(95lpm)
Maximum Continuous Operating PSI:	3000 psi (211 kg/cm ²)
Maximum Back Pressure	1500 psi (105 kg/cm ²)
Output shaft Options:	2" (51mm) Round 2-9/16" (65mm) Round 2" (51mm)Hexagon

OUTPUT SPEED		OUTPUT TORQUE	
FLOW	SPEED	PRESSURE	TORQUE
GPM (LPM)	= RPM	PSI (kg/cm ²)	= Lb•Ft (N•m)
10 (38)	= 38	2000 (141)	= 1600 (2169)
12 (45)	= 45	2500 (176)	= 2000 (2712)
14 (53)	= 53	3000 (211)	= 2377 (3223)
16 (61)	= 60		
18 (68)	= 68		
20 (76)	= 75		
25 (95)	= 94		

MODEL 1955 & 1975

Maximum Auger Diameter:	36"(914mm)
Minimum Hydraulic Flow:	15gpm(57lpm)
Maximum Hydraulic Flow:	30gpm(114lpm)
Maximum Continuous Operating PSI:	3000 psi (211 kg/cm ²)
Maximum Back Pressure	1500 psi (105 kg/cm ²)
Output shaft Options:	2" (51mm) Round 2-9/16" (65mm) Round 2" (51mm)Hexagon

OUTPUT SPEED		OUTPUT TORQUE	
FLOW	SPEED	PRESSURE	TORQUE
GPM (LPM)	= RPM	PSI (kg/cm ²)	= Lb•Ft (N•m)
15 (57)	= 49	2000 (141)	= 1856 (2516)
18 (68)	= 58	2500 (176)	= 2328 (3156)
20 (76)	= 65	3000 (211)	= 2769 (3755)
22 (83)	= 71		
24 (91)	= 78		
26 (98)	= 84		
28 (106)	= 90		
30 (114)	= 97		

MODEL 2475

Maximum Auger Diameter:	36"(914mm)
Minimum Hydraulic Flow:	20gpm(76lpm)
Maximum Hydraulic Flow:	35gpm(132lpm)
Maximum Continuous Operating PSI:	3000 psi (211 kg/cm ²)
Maximum Back Pressure	1500 psi (105 kg/cm ²)
Output shaft Options:	2" (51mm) Round 2-9/16" (65mm) Round 2" (51mm)Hexagon

OUTPUT SPEED		OUTPUT TORQUE	
FLOW	SPEED	PRESSURE	TORQUE
GPM (LPM)	= RPM	PSI (kg/cm ²)	= Lb•Ft (N•m)
20 (76)	= 52	2000 (141)	= 2308 (3129)
22 (83)	= 57	2500 (176)	= 2895 (3925)
24 (91)	= 63	3000 (211)	= 3451 (4686)
26 (98)	= 68		
28 (106)	= 73		
30 (114)	= 78		
35 (132)	= 93		

MODEL 3575

Maximum Auger Diameter:	48"(1219mm)
Minimum Hydraulic Flow:	24gpm(91lpm)
Maximum Hydraulic Flow:	30gpm(114lpm)
Maximum Continuous Operating PSI:	2500 psi (176 kg/cm ²)
Maximum Working Back Pressure	300 psi (21 kg/cm ²)
Output shaft Options:	2" (51mm)Hexagon

OUTPUT SPEED		OUTPUT TORQUE	
FLOW	SPEED	PRESSURE	TORQUE
GPM (LPM)	= RPM	PSI (kg/cm ²)	= Lb•Ft (N•m)
24 (91)	= 45	1500 (105)	= 2472 (3352)
27 (102)	= 50	2000 (141)	= 3296 (4469)
30 (114)	= 56	2500 (176)	= 4120 (5586)

Output speed and torque specifications are based on theoretical values and are provided for comparative purposes only.

McMillen is continually striving to improve its products. Therefore, we reserve the right to make changes to our products or specifications at any time without notice or obligation.

X75 SERIES AUGER DRIVE ASSEMBLIES

X975 / X1475 / X1975 / X2475 HYDRAULIC DRIVE UNITS



18

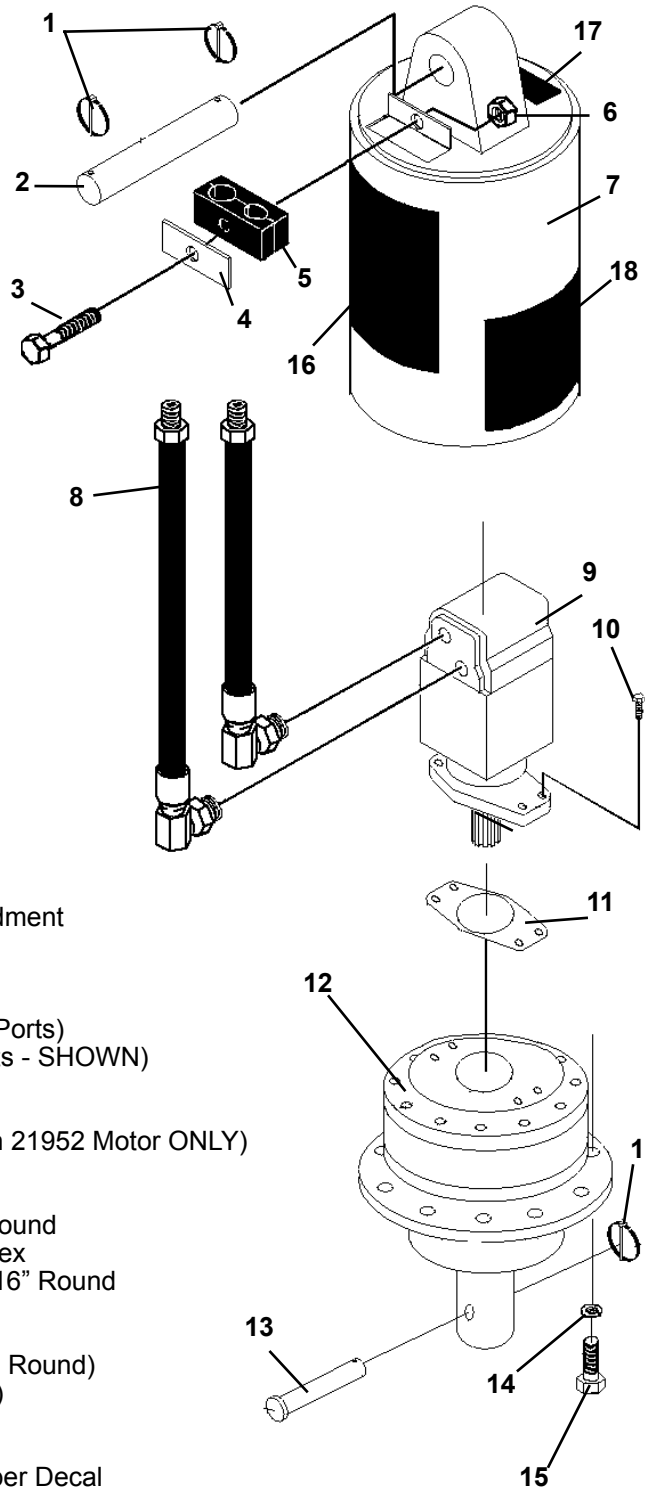

REF. #	PART #	QTY	DESCRIPTION
1	21169	3	Lynch Pin
2	22256	1	Pin, 1.25" x 6" Long
3	1096	1	.50" x 3.00" Long Capscrew
4	22315	1	Hose Plate
5	22316	1	Hose Cushion
6	1542	1	.50" Nylock Nut
7	23533	1	Motor Housing & Pendant Weldment
8	37968	2	Hose
9	89663	1	Hydraulic Motor 975
	89319	1	Hydraulic Motor 1475
	85726	1	Hydraulic Motor 1975 (Bottom Ports)
	21952	1	Hydraulic Motor 1975 (Top Ports - SHOWN)
	89664	1	Hydraulic Motor 2475
	45456*	-	Replacement Seal Kit
	21777*	-	Replacement Seal Kit (Used on 21952 Motor ONLY)
10	1907	4	.50" x 1.25" SHC Capscrew
11	22532	1	Motor Gasket
12	23525	1	Planetary Gear Reduction-2" Round
	23526	1	Planetary Gear Reduction-2" Hex
	23527	1	Planetary Gear Reduction-2 9/16" Round
13	22261	1	Clevis Pin, .62" x 4" (2" Round)
	22262	1	Clevis Pin, .88" x 4.50" (2-9/16" Round)
	22263	1	Clevis Pin, .75" x 4.50" (2" Hex)
14	1503	8	.38" Lock Washer
15	1046	8	.38" x 1.75" Long Capscrew
16	40552	1	Extreme Duty 975 Model Number Decal
	40549	1	Extreme Duty 1475 Model Number Decal
	40550	1	Extreme Duty 1975 Model Number Decal
	40551	1	Extreme Duty 2475 Model Number Decal
17	----	1	Serial Tag Identification Location
18	22680	2	Safety Decal

* Field Replacement of Internal Motor Seals Voids Warranty.

M-364
5-7-08-5

X3575 AUGER DRIVE ASSEMBLY

ASSEMBLY #24990

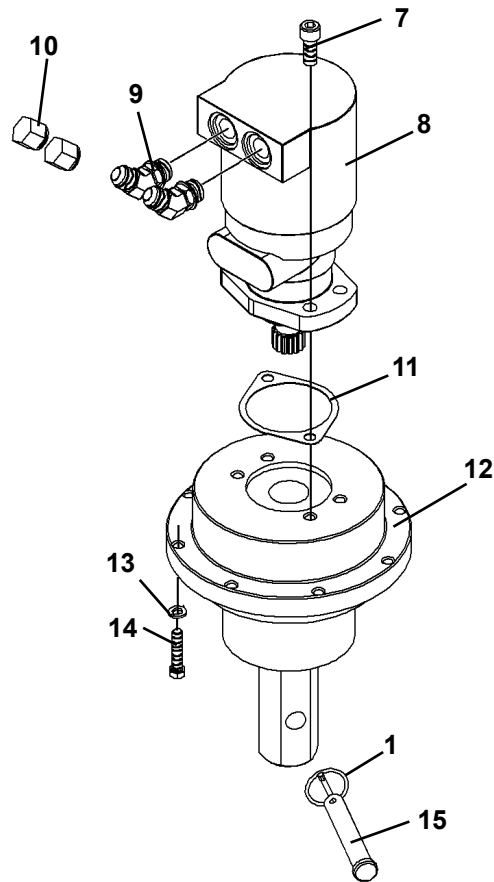
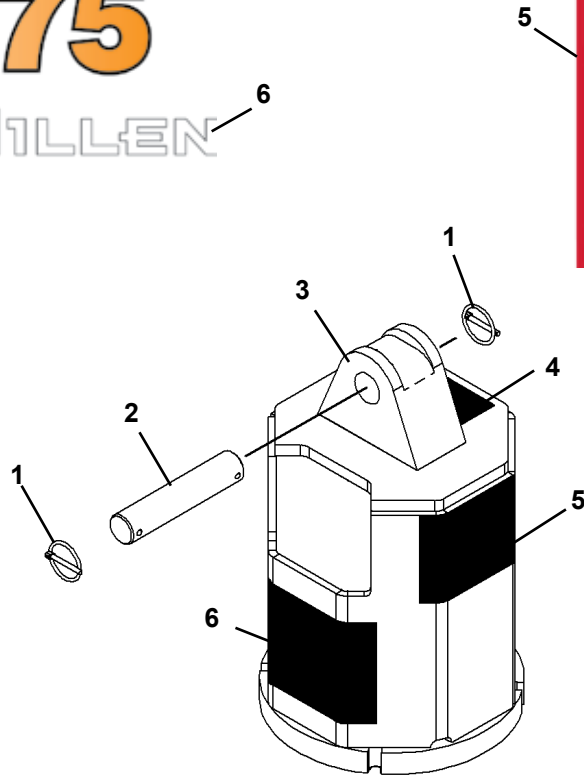

M-1597 5-6-08

X3575 AUGER DRIVE ASSEMBLY

ASSEMBLY #24990

<u>ITEM</u>	<u>REQ'D</u>	<u>PART NO.</u>	<u>DESCRIPTION</u>
1	3	21169	Klik Pin
2	1	22256	Pivot Pin
3	1	112547	Planetary Housing
4	1	----	Serial Number Identification Tag Location
5	2	22680	Danger Decal
6	1	41070	Model / Logo Decal
7	4	1907	.50" UNC X 1.25" Sockethead Capscrew
8	1	112522	Hydraulic Motor
9	2	22593	45° Elbow, 10MBo-10MJ
10	2	3271	Cap
11	1	22532	Gasket
12	1	23526	Planetary Gearbox
13	8	1503	.38" Lock Washer
14	8	1046	.38" UNC X 1.75" Hex Capscrew
15	1	22263	Pivot Pin

X3450 & X4450 AUGER DRIVE ASSEMBLIES

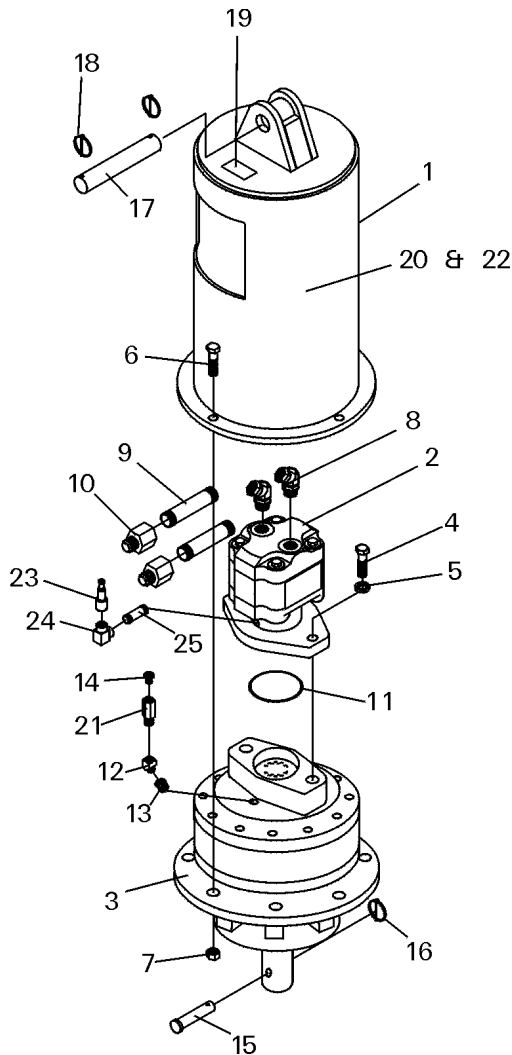

CAUTION!
 Drive Unit Models X3450 & X4450 are designed for MAXIMUM BACK PRESSURES OF 400 PSI. A **Drain Line Kit (Part #21218)** is available for back pressures exceeding 400 psi. To order, contact your Equipment Dealer or call McMillen's Sales Department at the numbers listed on the first page of this manual.

REF.#	PART #	QTY	DESCRIPTION
1	21650	1	Motor Housing & Pendent Weldment
2	21954	1	3450 Hydraulic Motor
	21955	1	4450 Hydraulic Motor
3	22498	1	Planetary Gear Reduction, 2" Hex
4	1895	2	.62"-11 x 2" Long, HHCS, Zinc, Gr. 5
5	1506	2	.62" Lockwasher
6	22344	4	.56"-12 x 2" Long, HHCS, Gr. 5
7	22351	4	.56"-12 "Uni-Torque" Lock Nut
8	22601	2	90° "O" Ring Motor Fitting
9	3210	2	.75" x 6" Sch. 80 Pipe, .75" NPT Male ends
10	22586	.2	75" NPT Female / #12 JIC Male Straight Fitting
11	22609	1	"O" Ring
12	3393	1	45° Fitting .25" Female Pipe x .25" Male pipe
13	22610	.1	50° NPT to .25" NPT Reducing Bushing
14	22588	1	.25"-Flush Head Breather Vent
15	22263	1	Clevis Pin, .75" x 4.50"
16	21169	1	Lynch Pin
17	22256	1	Pin, 1.25" x 6" Long
18	21169	2	Lynch Pins
19	22677	1	Model/Serial# ID Plate
20	22680	2	Safety Decal
21	22589	1	Check Valve, .25" NPT-Male to .25" Female
22	22654	2	Extreme Duty McMillen Decal
23	22561	1	Male Quick Coupler
24	3057	1	.25" NPT Female 90° Elbow
25	22562	1	.25" NPT Nipple, 1.50" Long

M-133 5-7-08-5

X1455 & X1955 AUGER DRIVE ASSEMBLIES

SERVICE PARTS

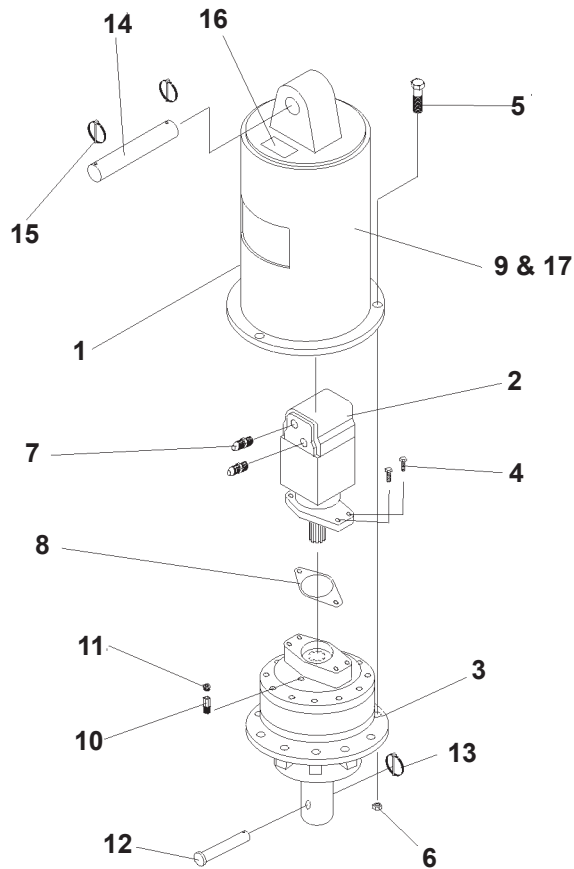

<u>REF. #</u>	<u>QTY</u>	<u>PART #</u>	<u>DESCRIPTION</u>
1	1	21644	Motor Housing & Pendant Weldment
2	1	89319	Hydraulic Motor 1455
	1	85726	Hydraulic Motor 1955
	-	45456	Replacement Seal Kit
3	1	23276	Planetary Gear Reduction-2" Hex
	-	23792	Replacement Seal (Omni)
4	4	22336	.50"-13 x 1.50" Long HHCS
5	3	22344	.56"-12 x 2.00" Long HHCS, Gr. 5
6	3	22351	.56"-12 "Uni-Torque" Lock Nut
7	2	22593	45° Motor Fitting
8	1	22532	Motor Gasket
9	2	22654	Extreme Duty McMillen Decal
10	1	22533	Check Valve, .25" NPT Male to .25" NPT Female
11	1	22588	.25" NPT Flush Head Breather Vent
12	1	22263	Clevis Pin, .75" x 4.50" (2" Hex)
13	1	21169	Lynch Pin (2" Rnd., 2-9/16" Rnd., 2" Hex)
14	1	22256	Pin, 1.25" x 6" Long
15	2	21169	Lynch Pins
16	1	22677	Model # / Serial # ID Plate
17	2	22680	Safety Decal

950, 1450, 1950, & 2450 AUGER DRIVE ASSEMBLIES

SERVICE PARTS

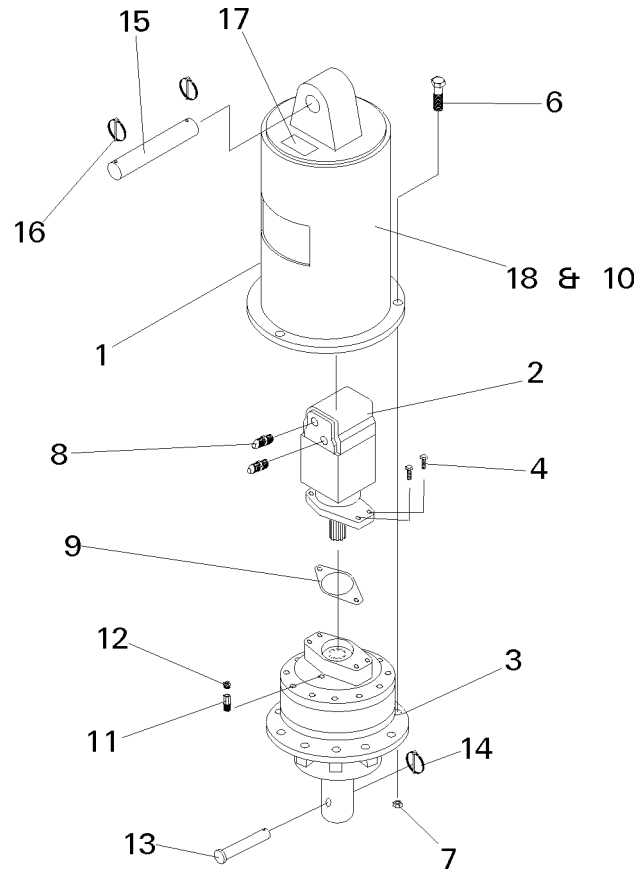

<u>REF. #</u>	<u>QTY</u>	<u>PART #</u>	<u>DESCRIPTION</u>
1	1	21645	Motor Housing & Pendant Weldment
2	1	21950	Hydraulic Motor 950
	1	21956	Hydraulic Motor 1450
	1	21952	Hydraulic Motor 1950
	1	21953	Hydraulic Motor 2450
3	1	22495	Planetary Gear Reduction-2" Round
	1	22496	Planetary Gear Reduction-2" Hex
	1	22497	Planetary Gear Reduction-2 9/16" Round
4	4	22336	.50"-13 x 1.50" Long HHCS
6	3	22344	.56"-12 x 2.00" Long HHCS, Gr. 5
7	3	22351	.56"-12 "Uni-Torque" Lock Nut
8	2	22593	45° Motor Fitting
9	1	22532	Motor Gasket
10	2	22654	Extreme Duty McMillen Decal
11	1	22533	Check Valve, .25" NPT Male to .25" NPT Female
12	1	22588	.25" NPT Flush Head Breather Vent
13	1	22261	Clevis Pin, .62" x 4" (2" Round)
		22262	Clevis Pin, .88" x 4.50" (2-9/16" Round)
		22263	Clevis Pin, .75" x 4.50" (2" Hex)
14	1	21169	Lynch Pin (2" Rnd., 2-9/16" Rnd., 2" Hex)
15	1	22256	Pin, 1.25" x 6" Long
16	2	21169	Lynch Pins
17	1	22677	Model # / Serial # ID Plate
18	2	22680	Safety Decal

M-132 5-7-08-3

1200, 1600 & 2200 AUGER DRIVE ASSEMBLIES

SERVICE PARTS

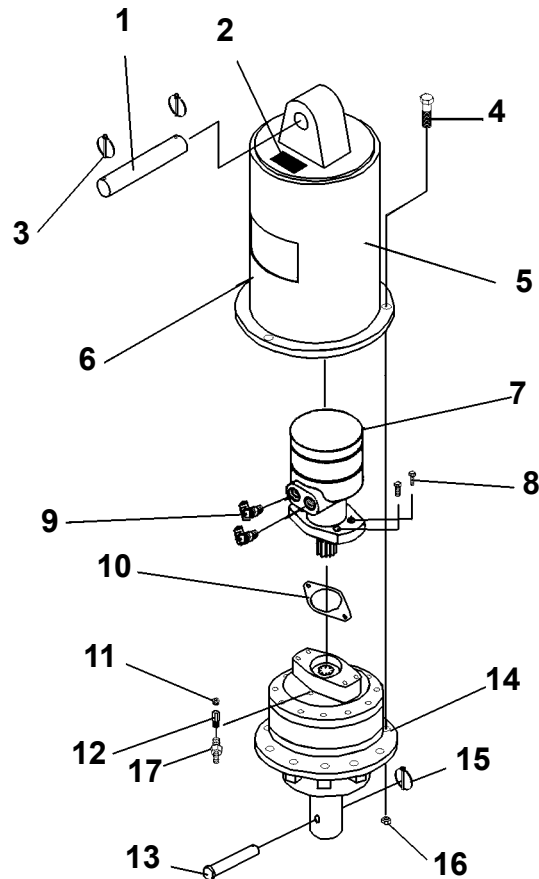

<u>REF. #</u>	<u>PART #</u>	<u>QTY</u>	<u>DESCRIPTION</u>
1	22256	1	Pin, 1.25" x 6" Long
2	22677	1	Model # / Serial # ID Plate
3	21169	2	Lynch Pins
4	22344	3	.56"-12 x 2.00" Long HHCS, Gr. 5
5	22680	2	Safety Decal
5	22654	2	Extreme Duty McMillen Decal
6	21644	1	Motor Housing & Pendant Weldment
7	85725	1	Hydraulic Motor 1200
	89319	1	Hydraulic Motor 1600
	89320	1	Hydraulic Motor 2200
8	1907	4	.50" x 1.25" SHC Capscrew
9	22593	2	45° Motor Fitting
10	45412	1	Motor Gasket
11	22588	1	.25" NPT Flush Head Breather Vent
12	22533	1	Check Valve, .25" NPT Male to .25" NPT Female
13	22261	1	Clevis Pin, .62" x 4" (2" Round)
	22262		Clevis Pin, .88" x 4.50" (2-9/16" Round)
	22263		Clevis Pin, .75" x 4.50" (2" Hex)
14	23274	1	Planetary Gear Reduction-2" Round
	23276	1	Planetary Gear Reduction-2" Hex
	23275	1	Planetary Gear Reduction-2 9/16" Round
15	21169	1	Lynch Pin (2" Rnd., 2-9/16" Rnd., 2" Hex)
16	22351	3	.56"-12 "Uni-Torque" Lock Nut
17	3089	1	Straight Adapter 6MP-4FP

Limited Warranty

Except for the Excluded Products as described below, all new products are warranted to be free from defects in material and/or workmanship during the Warranty Period, in accordance with and subject to the terms and conditions of this Limited Warranty.

1. Excluded Products. The following products are excluded from this Limited Warranty:

(a) Any cable, part that engages with the ground (i.e. sprockets), digging chain, bearing, teeth, tamping and/or demolition head, blade cutting edge, pilot bit, auger teeth and broom brush that either constitutes or is part of a product.

(b) Any product, merchandise or component that, in the opinion of Paladin Light Construction¹, has been (i) misused; (ii) modified in any unauthorized manner; (iii) altered; (iv) damaged; (v) involved in an accident; or (vi) repaired using parts not obtained through Paladin Light Construction.

2. Warranty Period. The Limited Warranty is provided only to those defects that occur during the Warranty Period, which is the period that begins on the first to occur of: (i) the date of initial purchase by an end-user, (ii) the date the product is first leased or rented, or (iii) the date that is six (6) months after the date of shipment by Paladin Light Construction as evidenced by the invoiced shipment date (the "Commencement Date") and ends on the date that is twenty-four (24) months after the Commencement Date. **(NOTE: The Planetary Gearbox ONLY carries an additional 3 years warranty.)**

3. Terms and Conditions of Limited Warranty. The following terms and conditions apply to the Limited Warranty hereby provided:

(a) Option to Repair or Replace. Paladin Light Construction shall have the option to repair or replace the product.

(b) Timely Repair and Notice. In order to obtain the Limited Warranty, (i) the product must be repaired within thirty (30) days from the date of failure, and (ii) a claim under the warranty must be submitted to Paladin Light Construction in writing within thirty (30) days from the date of repair.

(c) Return of Defective Part or Product. If requested by Paladin Light Construction, the alleged defective part or product shall be shipped to Paladin Light Construction at its manufacturing facility or other location specified by Paladin Light Construction, with freight PRE-PAID by the claimant, to allow Paladin Light Construction to inspect the part or product.

Claims that fail to comply with any of the above terms and conditions shall be denied.

LIMITATIONS AND EXCLUSIONS.

THIS LIMITED WARRANTY IS IN LIEU OF ALL OTHER WARRANTIES, EXPRESS OR IMPLIED, INCLUDING WITHOUT LIMITATION THE WARRANTIES OF MERCHANTABILITY, FITNESS FOR A PARTICULAR PURPOSE AND ANY WARRANTY BASED ON A COURSE OF DEALING OR USAGE OF TRADE.

IN NO EVENT SHALL PALADIN LIGHT CONSTRUCTION BE LIABLE FOR CONSEQUENTIAL OR SPECIAL DAMAGES.

IN NO EVENT SHALL PALADIN LIGHT CONSTRUCTION BE LIABLE FOR ANY LOSS OR CLAIM IN AN AMOUNT IN EXCESS OF THE PURCHASE PRICE, OR, AT THE OPTION OF PALADIN LIGHT CONSTRUCTION, THE REPAIR OR REPLACEMENT, OF THE PARTICULAR PRODUCT ON WHICH ANY CLAIM OF LOSS OR DAMAGE IS BASED. THIS LIMITATION OF LIABILITY APPLIES IRRESPECTIVE OF WHETHER THE CLAIM IS BASED ON BREACH OF CONTRACT, BREACH OF WARRANTY, NEGLIGENCE OR OTHER CAUSE AND WHETHER THE ALLEGED DEFECT IS DISCOVERABLE OR LATENT.

¹Attachment Technologies Inc., a subsidiary of Paladin Brands Holding, Inc. (PBHI) is referred to herein as Paladin Light Construction.