

Harley

Model T-6

B ~ Series Rakes

Serial Numbers

T65B001 - T68B150

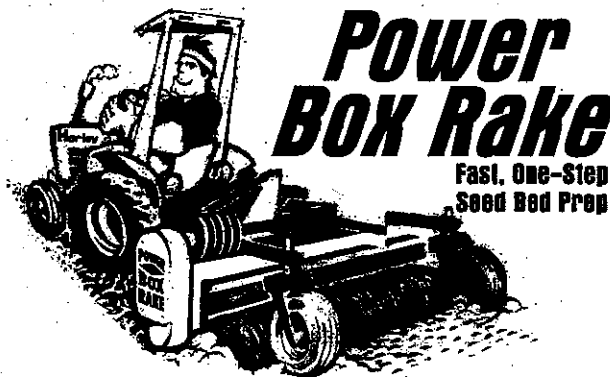

Parts requirements are subject to change without notice and parts may be substituted by Glenmac, Inc.

Please refer to the latest parts price book for current parts pricing, or call (800) 437-9779, Fax (701) 251-9259, E-mail customer_service@glenmac.com

DECALS

 **WARNING**

DO NOT ALLOW ANYONE TO OPERATE POWER RAKE WHO HAS **NOT** BEEN PROPERLY TRAINED IN ITS SAFE OPERATION AND HAS **NOT** READ AND UNDERSTOOD THE OPERATOR'S MANUAL.

BEFORE ATTACHING, CHECK TRACTOR'S 3PT. LIFT CAPACITY TO ENSURE ITS ABILITY TO SAFELY HANDLE THE WEIGHT.

MAX. PTO SPEED IS 540 RPM'S.

DO NOT OPERATE WITHOUT GUARDS/SHIELDS IN PLACE AND IN GOOD WORKING ORDER.

STOP ALL MOVING PARTS INCLUDING TRACTOR ENGINE BEFORE CLEANING, UNPLUGGING, ADJUSTING, AND/OR PERFORMING MAINTENANCE.

KEEP BYSTANDERS 10 FEET FROM POWER RAKE WHEN IN OPERATION.

FAILURE TO FOLLOW THE ABOVE SAFETY SUGGESTIONS AND THOSE IN THE OPERATOR'S MANUAL CAN RESULT IN SERIOUS INJURY OR DEATH.

"A" - P970100

 **WARNING**

		
---	---	---

STAY CLEAR OF THE MACHINE WHILE IT IS RUNNING. Contact with rotating rollers can cause serious injury.

P970200

"B" - P970200

 **DANGER**

	
--	---

ROTATING PART HAZARD

- KEEP HANDS, HAIR AND CLOTHING AWAY FROM MOVING PARTS.
- CLOSE AND SECURE ALL SHIELDS BEFORE OPERATING.

FAILURE TO DO SO COULD RESULT IN SERIOUS INJURY OR DEATH

"C" - P970300

FRAME AND DRIVE ASSEMBLY

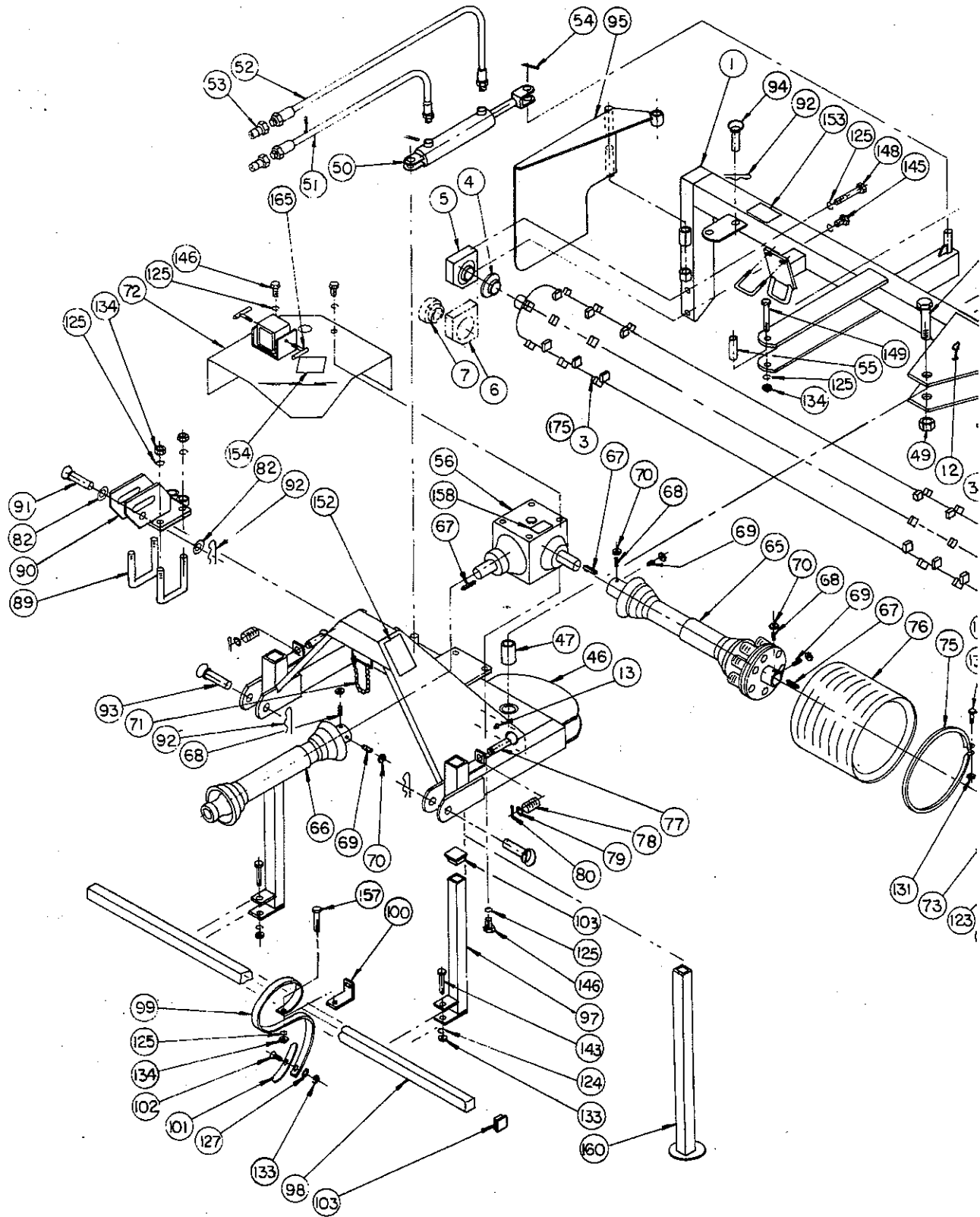

FRAME AND DRIVE ASSEMBLY

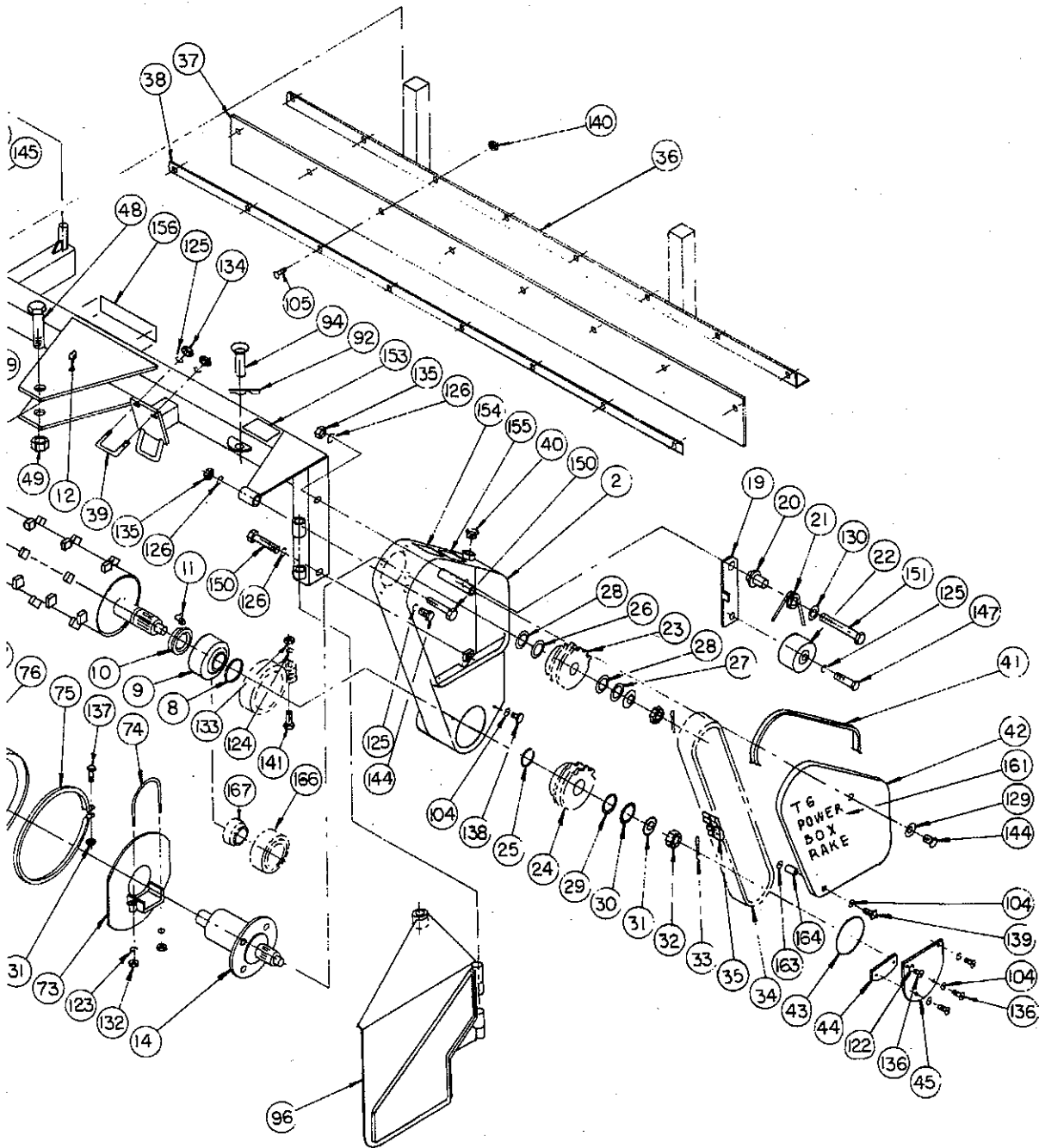

CASTOR WHEEL ASSEMBLY

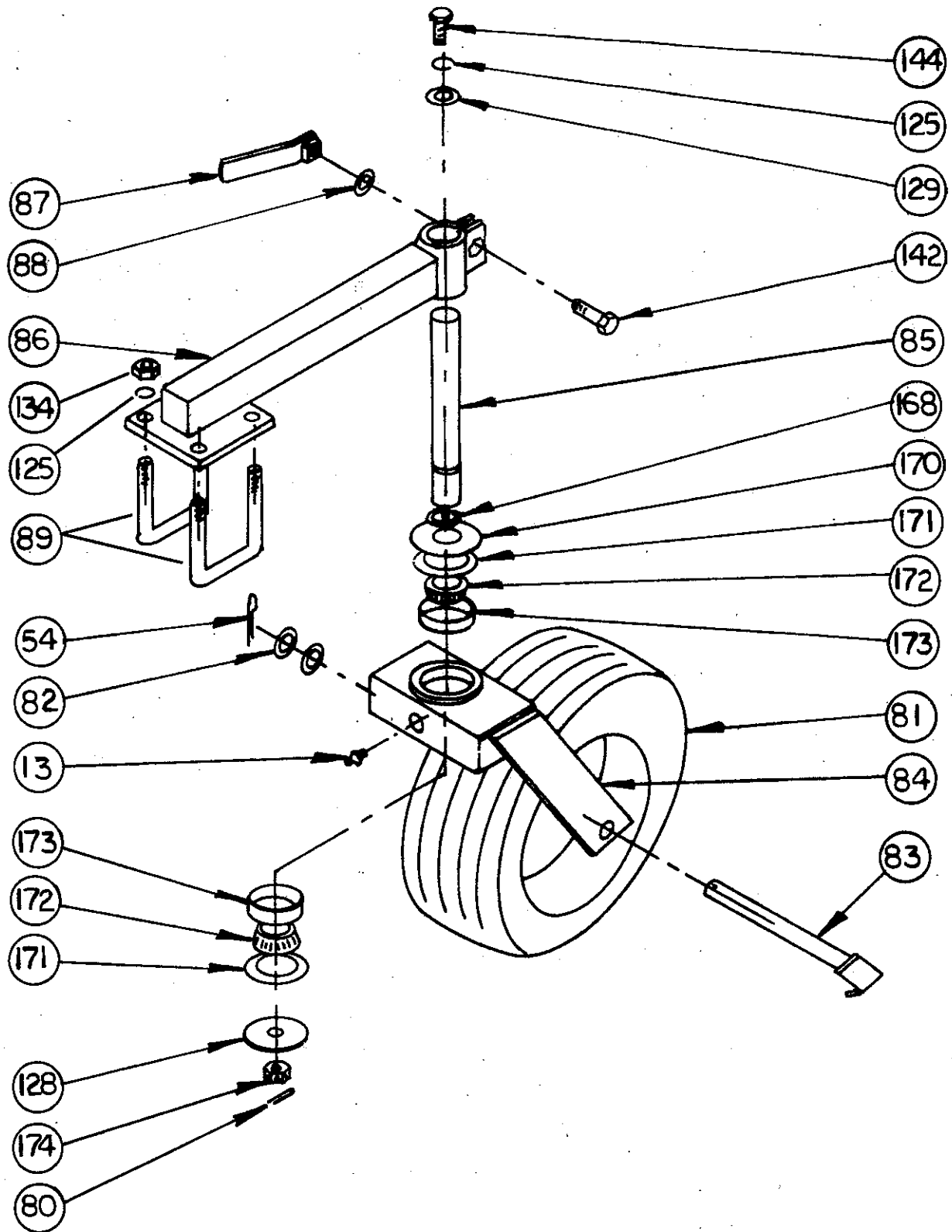

PTO ASSEMBLY

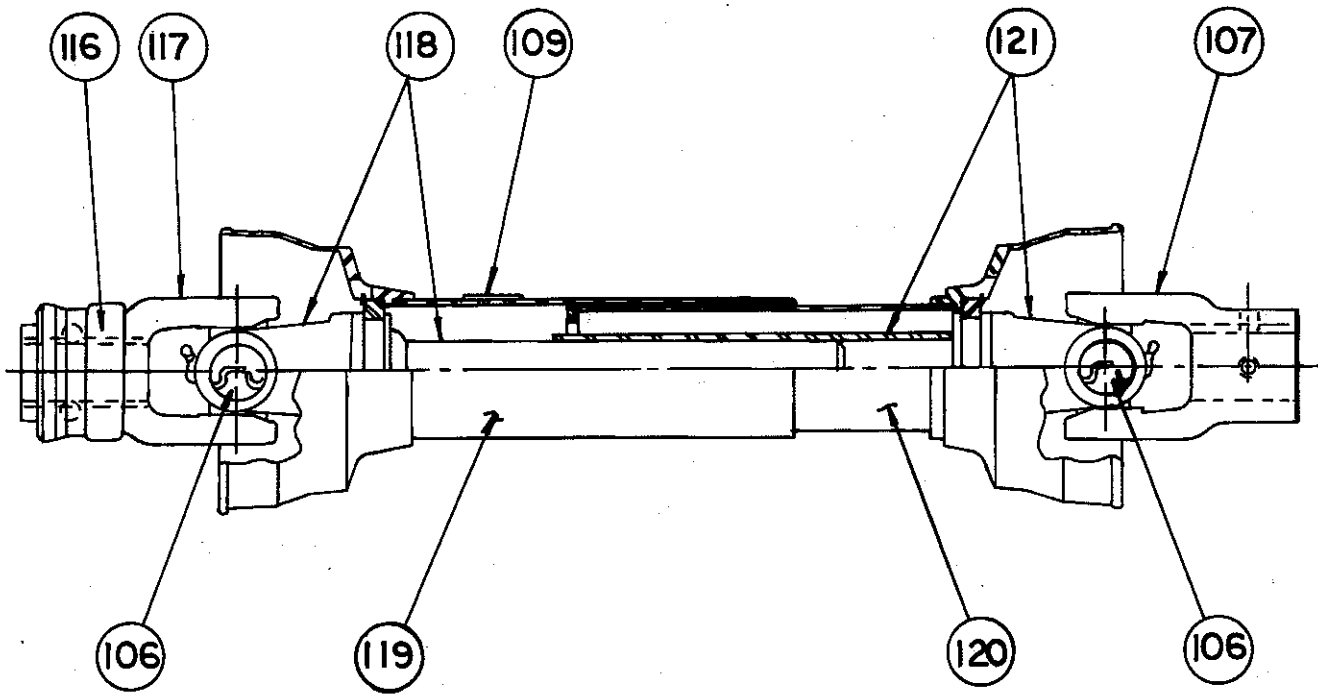

FRONT PTO

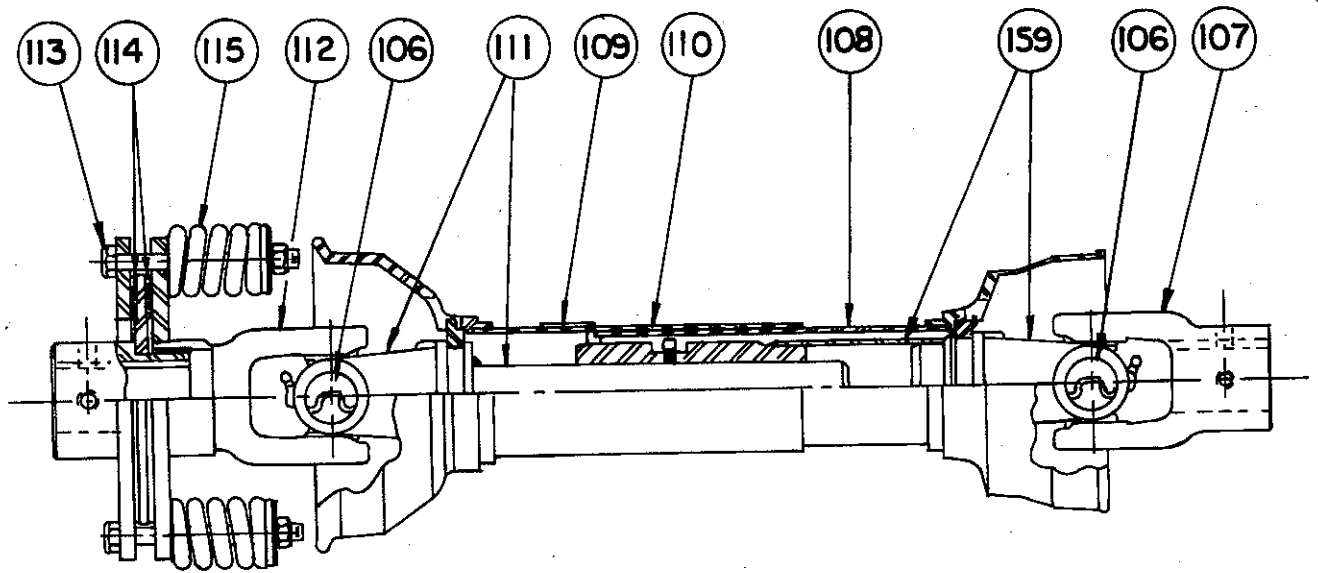

SIDE PTO

GEAR BOX ASSEMBLY

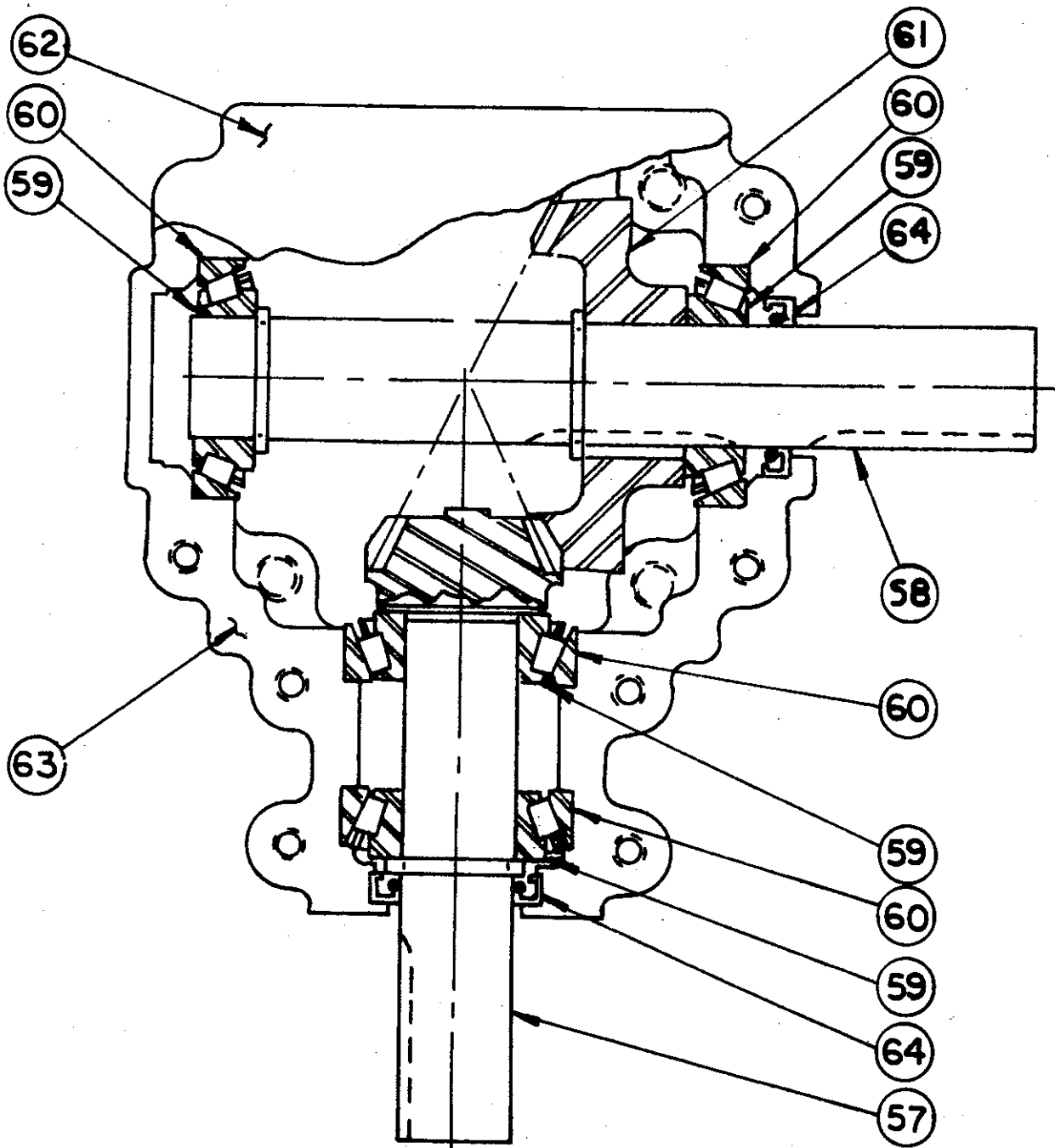

GEAR BOX

PARTS LIST

ITEM #	QTY	PART NO.	DESCRIPTION	ITEM #	QTY	PART NO.	DESCRIPTION
1	1	M6402	Frame	60	4	P205410	Tapered Bearing Cup
2	1	M6419	Chain Case	61	1	P205401	Gear (2:1 Ratio 30 Tooth)
3	1	M6446	Tooth Roller	62	1	P205409	Casting Top Half
4	1	P015301	1-3/8" Eccentric Locking Collar	63	1	P205402	Casting Bottom Half
5	1	M6261	1-3/8" Tap Base Bearing	64	2	P205404	Seal (1-3/8" Shaft)
6	1	P015200	Tap Base Housing	65	1	P400700-1 & -2	Side PTO with Clutch
7	1	P009500	1-3/8" Bearing Insert	66	1	P400400-1 & -2	Front PTO
8	1	P500203	O-Ring 3/8" x 2-5/8"	67	3	M5000-5	5/16" x 2 Square Key
9	1	M6687	1-1/2" Cartridge Bearing (See 166 & 167)	68	3	P108610	3/8" x 5/8" Set Screw
10	1	P015300	1-1/2" Eccentric Locking collar	69	3	P108616	3/8" x 1" Set Screw
11	1	P620100	1/4"-28 x 90 Grease Fitting	70	6	P155400	3/8" Hex Jam Nut
12	2	P620000	1/4"-28 x 45 Grease Fitting	71	1	M6266	PTO Support Chain
13	3	P620200	1/4"-28 Straight Grease Fitting	72	1	M6440	Gear Box Shield
14	1	M6256	Bearing Housing Assembly	73	1	M6258	Clutch Shield Mount
15	1	M6227	Bearing housing	74	1	P128500	5/16" U-Bolt
16	1	P635005	Drive Shaft	75	1	P128605	Band Clamp
17	2	P009204	Ball Bearing	76	1	M6262	Shield
18	1	P975600	Plastic Plug	77	2	M8263	5/8" Pin
19	1	M6417	Tensioner Arm	78	2	P604500	Compression Spring
20	1	M6418	Tensioner Pivot	79	2	P852001	16mm Washer
21	1	P604100	Torsion Spring	80	4	P116204	1/8" x 1" Cotter Pin
22	1	P477005	Idler Roller	81	2	P756100	Wheel and Tire
23	1	P661600	16 Tooth Sprocket 60-2	82	4	P850812	3/4" SAE Washer
24	1	P661802	18 Tooth Sprocket 60-2	83	2	M6215	Axle
25	1	P952100	1-1/2" Snap Ring	84	2	M6211	Caster Fork
26	1	P855522	18 Gage 1-3/8" Machine Bushing	85	2	M6701	Caster Shaft
27	1	P855322	14 Gage 1-3/8" Machine Bushing	86	2	M6291	Support Arm
28	2	P855122	10 Gage 1-3/8" Machine Bushing	87	2	M6415	Handle
29	1	P855524	18 Gage 1-1/2" Machine Bushing	88	2	P852608	1/2" Hardened Washer
30	1	P855124	10 Gage 1-1/2" Machine Bushing	89	6	P128318	1/2" x 4-1/4" U-Bolt
31	2	P850612	3/4" Flat Washer	90	1	M6439	Third Hitch Point
32	2	P158000	3/4"-16 Hex Slotted Nut	91	1	M5003	3/4" x 3-3/4" Pin
33	2	P116256	5/32" x 1-1/2" Cotter Pin	92	5	P622600	Hair Pin Clips
34	1	M6436	Drive Chain (75 Pitch)	93	2	M8073	7/8" Pin
35	1	P630202	60-2 Connector	94	2	M6442	3/4" x 2-1/2" Pin
36	1	M6426	Barrier Mount	95	1	M6429	End Plate, Right
37	1	M6427	Barrier	96	1	M6430	End Plate, Left
38	1	M6428	Strap	97	2	M6416	Scarifier Lift Tube
39	2	P128213	1/2" x 2-3/4" U-Bolt	98	1	M6011	Tine Bar
40	1	P278001	Vent Plug	99	6	P701000	S-Tine
41	1	M6441	Seal	100	6	P701010	Tine Bracket
42	1	M6424	Cover Assembly	101	6	P700300	S-Tine Shovel
43	1	P500202	O-Ring 1/16" x 4-3/4"	102	6	P700400	3/8" x 1 1/4" Shovel Bolt
44	1	M8272	Cover Tab	103	2	P955800	1-1/4" Plastic Cap
45	1	M8241	Cover	104	4	P500300	1/4" Seal Washer
46	1	M6407	Mast Weldment	105	8	P104506	5/16" x 1-1/2" Carriage Bolt
47	1	M6218	Bushing	106	1	P400002	14R Repair Kit
48	1	P101622	1" x 5-1/2" Fine Thread Bolt	107	2	P400036	1-3/8" Round End Yoke
49	1	P156401	1" Lock Nut	108	1	P400710	Inner Guard
50	1	P256000	Hydraulic Cylinder (1-1/2" x 8")	109	2	P970400	Safety sign
51	1	M6438	Restricted Hose Assembly	110	1	P403102	Outer Guard
52	1	P252500	Hose Assembly	111	1	P400705	Yoke and Shaft
53	2	P272600	Quick Coupler	112	1	P400704	Friction Clutch Assembly
54	4	P116307	3/16" x 1-3/4" Cotter Pin	113	6	P400712	Bolt
55	1	M6219	Sleeve	114	6	P400019	Friction Disc
56	1	P205400	Gear Box	115	6	P400020	Spring
57	1	P205408	Geared Pinion Shaft	116	1	P400031	Lock Yoke Repair Kit
58	1	P205413	Cross Shaft	117	1	P400803	Lock Yoke Assembly
59	4	P205403	Tapered Bearing Cone	118	1	P400804	Yoke and Shaft
				119	1	P400805	Outer Guard
				120	1	P400809	Inner Guard

PARTS LIST

ITEM #	QTY	PART NO.	DESCRIPTION
121	1	P400807	Yoke and Tube
122	2	P851104	1/4" Lock washer
123	2	P851105	5/16" Lock Washer
124	3	P851106	3/8" Lock Washer
125	36	P851108	1/2" Lock Washer
126	3	P851110	5/8" Lock Washer
127	6	P850105	3/8" Flat Washer
128	2	M6223	1/2" x 3" Flat Washer
129	3	M5009-5	1/2" Flat Washer
130	1	P850109	9/16" Flat Washer
131	1	P158003	1/4" Hex Lock Nut
132	2	P150500	5/16" Hex Nut
133	9	P150600	3/8" Hex Nut
134	23	P150800	1/2" Hex Nut
135	2	P151000	5/8" Hex Nut
136	4	P110901	1/4" x 3/4" Button Head Bolt
137	1	P100405	1/4" x 1-1/4" Square Head Bolt
138	1	P100402	1/4" x 1/2" Hex Head Bolt
139	1	P100406	1/4" x 1-1/2" Hex Head Bolt
140	8	P155350	5/16" Center Lock Nut
141	1	P100608	3/8" x 2" Hex Head Bolt
142	7	P102808	1/2" x 2" Fine Thread Bolt
143	2	P100611	3/8" x 2-3/4" Hex Head Bolt
144	7	P100804	1/2" x 1" Hex Head Bolt
145	1	P100805	1/2" x 1-1/4" Hex Head Bolt
146	6	P100806	1/2" x 1-1/2" Hex Head Bolt
147	1	P100810	1/2" x 2-1/2" Hex Head Bolt
148	1	P100816	1/2" x 4" Hex Head Bolt
149	1	P100819	1/2" x 4-3/4" Hex Head Bolt
150	2	P101014	5/8" x 3-1/2" Hex Head Bolt
151	1	P101022	5/8" x 5-1/2" Hex Head Bolt
152	1	P970100	"A" Warning Decal
153	2	P970200	"B" Warning Decal
154	2	P970300	"C" Warning Decal
155	1	P975601	Lube Decal
156	1	P975800	Harley Logo Decal (Small)
157	1	P104811	1/2" x 2 3/4" Carriage Bolt
158	1	P970301	"C" Warning Decal (Small)
159	1	P400709	Yoke and Tube
160	1	M6455	Jack Stand
161	1	P975905	Decal Model T-6
162	1	*****	
163	1	P500302	1/4" Rubber Face Washer
164	1	P481010	Spacer Bushing
165	2	M6448	T-Handle
166	1	P015210	Cartridge Bearing Hsg
167	1	P010400	1 1/2" Cylindrical Insert
168	3	P952200	1 3/8" Snap Ring
169	1	M6301	Sleeve
170	2	P850620	1 1/4" Flat Washer
171	4	P852200	Felt Washer
172	4	P760300	Bearing Cone
173	4	P760500	Bearing Cup
174	2	P158006	1/2" Slotted Hex Nut
175	-	M6433	Bar Roller