



BRADCO

BY PALADIN

PARTS MANUAL

609 & 611 POWER BACKHOES

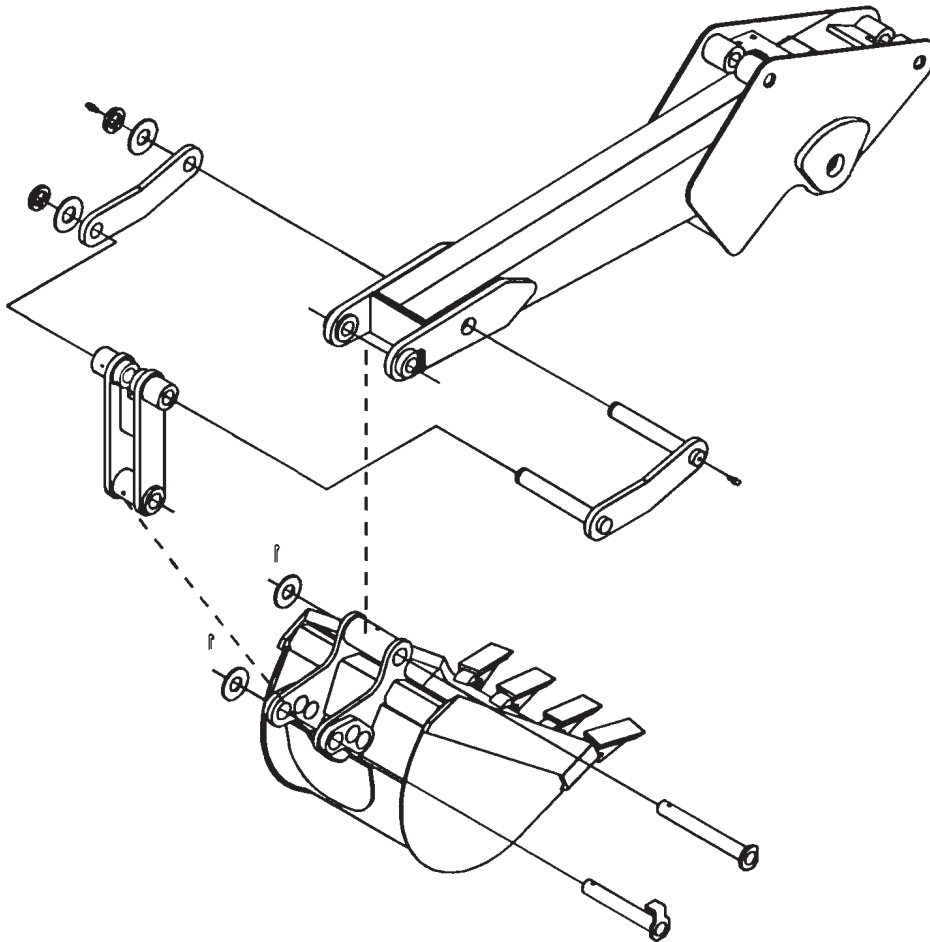

SERIAL NUMBER: _____

MODEL NUMBER: _____

Manual Number: PM557
Part Number: 75457
Rev. 9

Limited Warranty

Except for the Excluded Products as described below, all new products are warranted to be free from defects in material and/or workmanship during the Warranty Period, in accordance with and subject to the terms and conditions of this Limited Warranty.

1. Excluded Products. The following products are excluded from this Limited Warranty:

(a) Any cable, part that engages with the ground (i.e. sprockets), digging chain, bearing, teeth, tamping and/or demolition head, blade cutting edge, pilot bit, auger teeth and broom brush that either constitutes or is part of a product.

(b) Any product, merchandise or component that, in the opinion of Paladin Light Construction¹, has been (i) misused; (ii) modified in any unauthorized manner; (iii) altered; (iv) damaged; (v) involved in an accident; or (vi) repaired using parts not obtained through Paladin Light Construction.

2. Warranty Period. The Limited Warranty is provided only to those defects that occur during the Warranty Period, which is the period that begins on the first to occur of: (i) the date of initial purchase by an end-user, (ii) the date the product is first leased or rented, or (iii) the date that is six (6) months after the date of shipment by Paladin Light Construction as evidenced by the invoiced shipment date (the "Commencement Date") and ends on the date that is twenty-four (24) months after the Commencement Date.

3. Terms and Conditions of Limited Warranty. The following terms and conditions apply to the Limited Warranty hereby provided:

(a) Option to Repair or Replace. Paladin Light Construction shall have the option to repair or replace the product.

(b) Timely Repair and Notice. In order to obtain the Limited Warranty, (i) the product must be repaired within thirty (30) days from the date of failure, and (ii) a claim under the warranty must be submitted to Paladin Light Construction in writing within thirty (30) days from the date of repair.

(c) Return of Defective Part or Product. If requested by Paladin Light Construction, the alleged defective part or product shall be shipped to Paladin Light Construction at its manufacturing facility or other location specified by Paladin Light Construction, with freight PRE-PAID by the claimant, to allow Paladin Light Construction to inspect the part or product.

Claims that fail to comply with any of the above terms and conditions shall be denied.

LIMITATIONS AND EXCLUSIONS.

THIS LIMITED WARRANTY IS IN LIEU OF ALL OTHER WARRANTIES, EXPRESS OR IMPLIED, INCLUDING WITHOUT LIMITATION THE WARRANTIES OF MERCHANTABILITY, FITNESS FOR A PARTICULAR PURPOSE AND ANY WARRANTY BASED ON A COURSE OF DEALING OR USAGE OF TRADE.

IN NO EVENT SHALL PALADIN LIGHT CONSTRUCTION BE LIABLE FOR CONSEQUENTIAL OR SPECIAL DAMAGES.

IN NO EVENT SHALL PALADIN LIGHT CONSTRUCTION BE LIABLE FOR ANY LOSS OR CLAIM IN AN AMOUNT IN EXCESS OF THE PURCHASE PRICE, OR, AT THE OPTION OF PALADIN LIGHT CONSTRUCTION, THE REPAIR OR REPLACEMENT, OF THE PARTICULAR PRODUCT ON WHICH ANY CLAIM OF LOSS OR DAMAGE IS BASED. THIS LIMITATION OF LIABILITY APPLIES IRRESPECTIVE OF WHETHER THE CLAIM IS BASED ON BREACH OF CONTRACT, BREACH OF WARRANTY, NEGLIGENCE OR OTHER CAUSE AND WHETHER THE ALLEGED DEFECT IS DISCOVERABLE OR LATENT.

¹Attachment Technologies Inc., a subsidiary of Paladin Brands Holding, Inc. (PBHI) is referred to herein as Paladin Light Construction.

TABLE OF CONTENTS

SERVICE PARTS

MAINFRAME ASSEMBLY			#87443
Mainframe			
Swing Post			
Swing Cylinder			
Stabilizers			
Hose Bundle Clamps			
609 BOOM & DIPPER ASSEMBLY			#82623
611 BOOM & DIPPER ASSEMBLY			#82469
CONSOLE ASSEMBLY			#87442
VALVE ASSEMBLY			#2232
OPTIONAL SWING SPEED CONTROL			#83337
OPTIONAL STEP ASSEMBLY			#83650
CYLINDERS			
SWING CYLINDER			#81022
STABILIZER CYLINDER			#82980
609 BOOM CYLINDER			#82625
611 BOOM CYLINDER			#82476
609 DIPPER CYLINDER - SN #--8289 & UP			#85782
UP TO SN #--8289			#82624
611 DIPPER CYLINDER - SN #--8227 & UP			#85779
UP TO SN #--8227			#82478
BUCKET CYLINDER			#117548
HOSE SETS			
MAINFRAME HOSE SET			#82761
609 BOOM & DIPPER HOSE SET			#82762
611 BOOM & DIPPER HOSE SET			#82763
STABILIZER PAD OPTIONS			
FLAT STABILIZER PAD ASSEMBLY			#83055
GROUSER STABILIZER PAD ASSEMBLY			#83054
LARGE GROUSER STABILIZER PAD ASSEMBLY			#83057
RUBBER STABILIZER PAD ASSEMBLY			#83056
BUCKET OPTIONS			
	<u>STANDARD</u>	<u>SEVERE DUTY</u>	
12" BUCKET	#68212	#85012	
16" BUCKET	#68216	#85016	
18" BUCKET	#68218	#85018	
20" BUCKET	#68220	#85020	
24" BUCKET	#68224	#85024	
609 FIRST LINE REPAIR KIT			#83758
611 FIRST LINE REPAIR KIT			#83759
609 DECALS			#40235
611 DECALS			#40236

MAINFRAME ASSEMBLY

ASSEMBLY #87443

MAINFRAME

<u>NO</u>	<u>REQ'D</u>	<u>PART NO.</u>	<u>DESCRIPTION</u>
1	1	37554	Hose .50" X 36" 8FJX 90° Short Gooseneck - 8FJX 90° Short Gooseneck
2	1	3327	Tee
3	2	3049	Bushing 12MP - 8FP
4	1	3273	Coupling 8FP-8FJX
5	1	3211	Close Nipple .50 NPT (Inline Filter)
	1	3309	Heavy Close Nipple .50 NPT x 4.00" (Check Valve)
6	1	45691	Check Valve (Hex)
7	2	3189	Square Head Plug
8	1	45132	Inline Filter (Round)
9	2	1010	.25" UNC X 2.75" Hex Capscrew
	2	81595	Spacer
	8	1512	.25" Flat Washer
	2	1501	.25" Lock Washer
	2	1224	.25" UNC Hex Nut
10	1	82609	Priority Flow Divider
11	1	3071	90° Adapter 8MP-8MJ
12	1	37690	Hose .50" X 41" (SN#10067 & UP) 8FJX-8FJX 45° Gooseneck
	-	37577	Hose .50" X 39" 8FJX - 8FJX (UP TO SN#10067)
13	4	1043	.38" UNC X 1.00" Hex Capscrew (Pin retaining capscrews installed with Locktite Grade 242)
14	2	1514	.38" Flat Washer
15	2	81807	Spacer Tube
16	2	82423	Pin
	2	6616	Grease Zerk
17	1	82613	Thrust Washer 2.00 X .125"
18	2	1734	Snap Ring
19	2	82435	Bearing
20	1	82446	Mainframe (Includes (4) #83815 Bushings, (4) 82447 Bushings - Installed with Locktite Grade 680)
21	1	82090	Swing Lock Pin
22	As Req'd	82611	Thrust Washer 2.00" X .030"
	As Req'd	82612	Thrust Washer 2.00" X .060"
	As Req'd	82613	Thrust Washer 2.00" X .125"
23	3	1503	.38" Lock Washer
24	2	6799	Spacer
25	2	6186	Hose Clamp
26	2	82794	Bushing
27	2	1611	Cotter Pin .12 X 1.00"
28	1	82796	Linkage
29	1	1982	Shoulder Screw
30	4	6886	Rubber Bumper (Service Part ONLY)
	4	1542	.50" UNC Lock Nut
31	2	1226	.38" UNC Hex Nut
32	As Req'd	1528	.62" SAE Flat Washer
33	1	1666	Snap Ring

NOTE: Use thrust washers (Item #22) to adjust mainframe / swing post to minimum free play.

7728

5-3-05-2

MAINFRAME ASSEMBLY

ASSEMBLY #87443

SWING POST

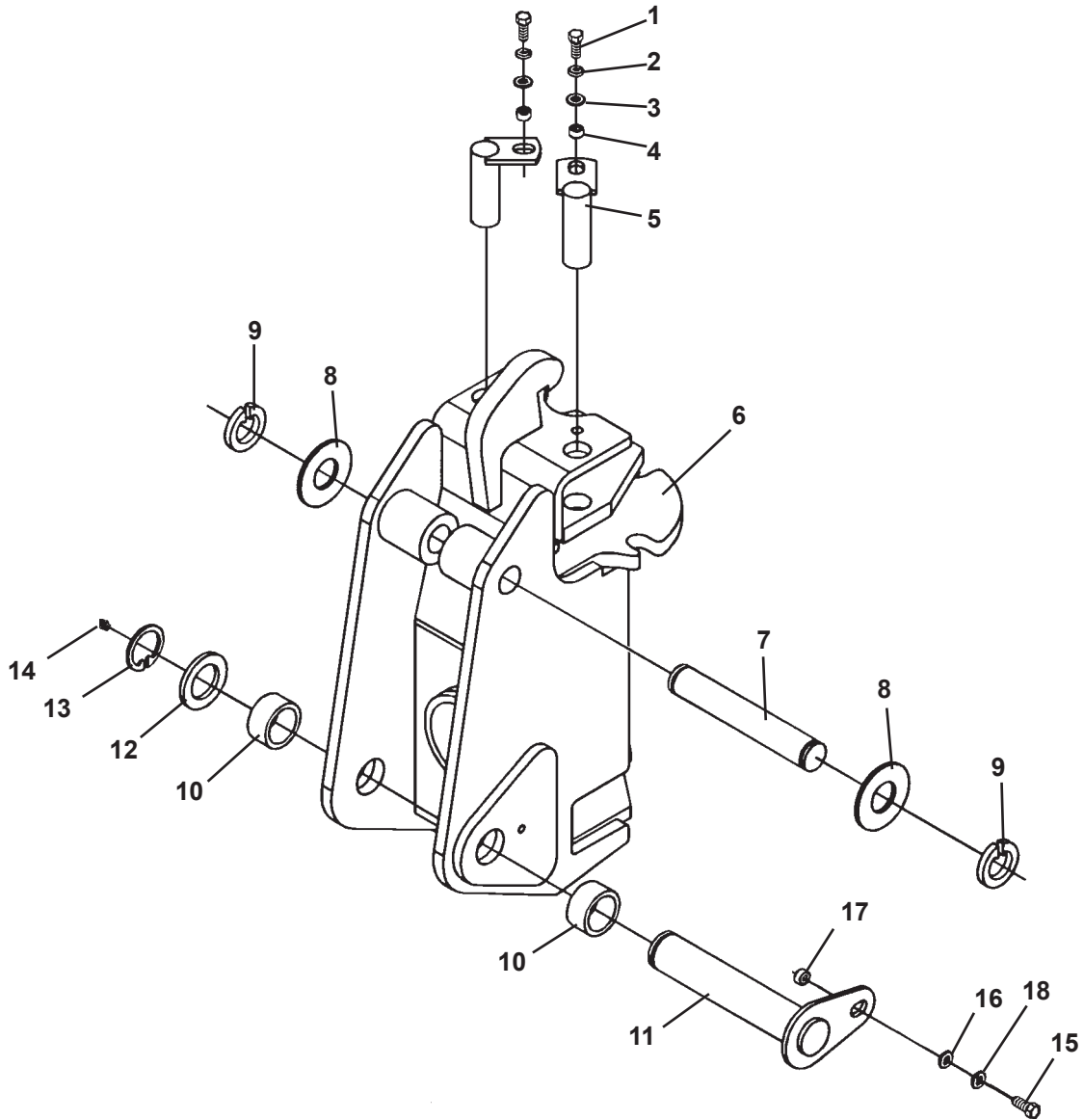

MAINFRAME ASSEMBLY

ASSEMBLY #87443

SWING POST

<u>NO</u>	<u>REQ'D</u>	<u>PART NO.</u>	<u>DESCRIPTION</u>
1	2	1043	.38" UNC X 1.00" Hex Capscrew (Installed with Locktite Grade 242)
2	2	1503	.38" Lock Washer
3	2	1514	.38" Flat Washer
4	2	81807	Spacer Tube
5	2	81847	Pin
6	1	82408	Swing Post (Includes (2) 82402 Bushings Installed with Locktite Grade 680)
7	1	82415 (1)	Pivot Pin
8	As Req'd	6623	Thrust Washer 1.38" X .031"
	As Req'd	64724	Thrust Washer 1.38" X .090"
	As Req'd	64725	Thrust Washer 1.38" X .125"
9	2	1650	Snap Ring
10	-	82402	Bushing (Included with Swing Post) (Installed with Locktite Grade 680)
11	1	82416	Pivot Pin
12	As Req'd	6622	Thrust Washer 1.75" X .082"
13	1	1651	Snap Ring
14	1	6616	Grease Zerk
15	1	1088	.50" UNC X 1.00" Hex Capscrew
16	1	1516	.50" Flat Washer
17	1	86149	Spacer Tube
18	1	1505	.50" Lock Washer

NOTE:

- (1) Pivot Pin #82415 is sold only in Pin Kit #86306. Kit includes one pin #82415, two thrust washers #6623 and two snap rings #1650.

MAINFRAME ASSEMBLY

ASSEMBLY #87443

SWING CYLINDERS

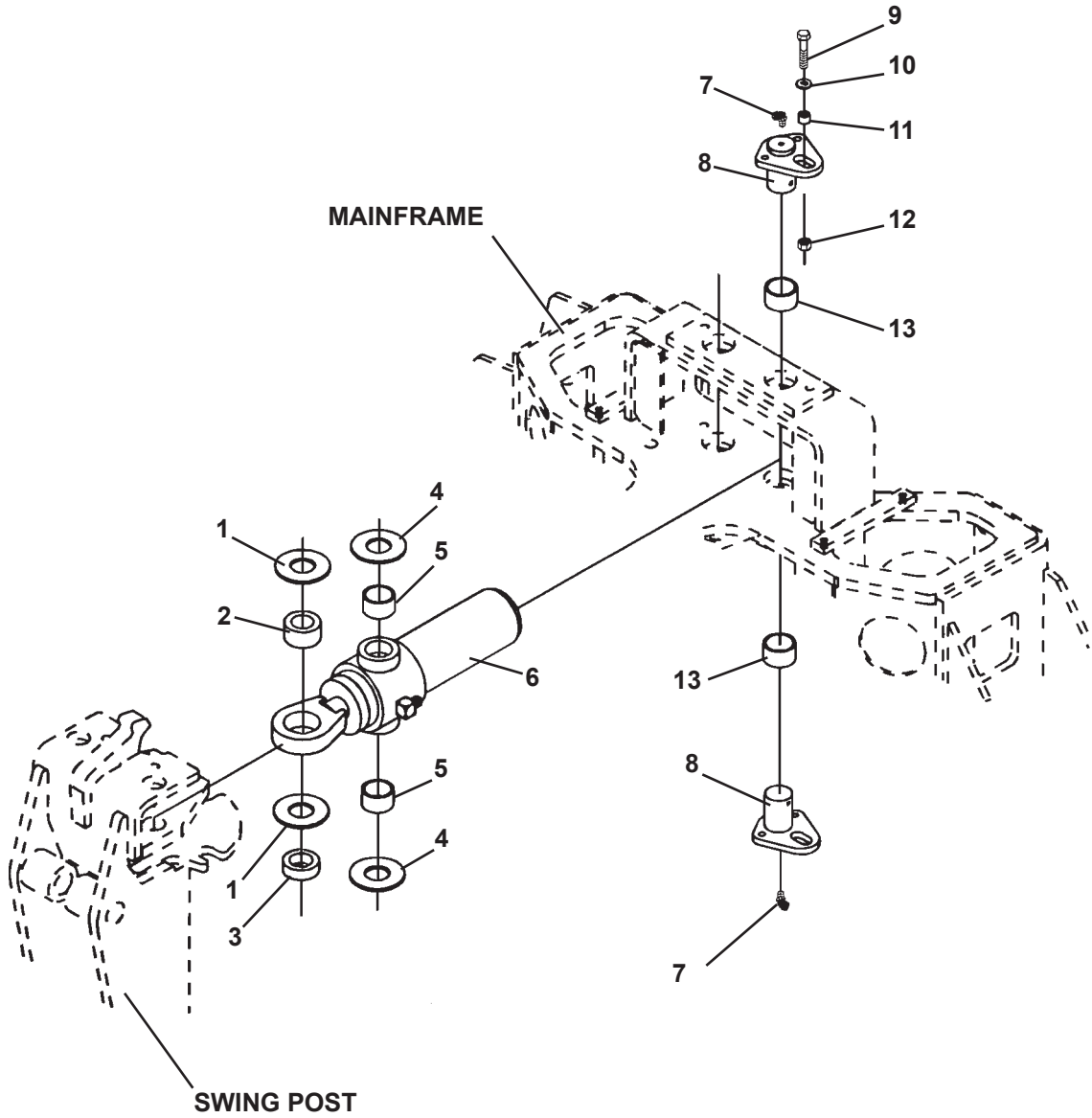

MAINFRAME ASSEMBLY

ASSEMBLY #87443

SWING CYLINDERS

<u>NO</u>	<u>REQ'D</u>	<u>PART NO.</u>	<u>DESCRIPTION</u>
1	As Req'd	57693	Thrust Washer 1.25" X .078"
	As Req'd	64727	Thrust Washer 1.25" X .145"
2	-	62523	Self Aligning Bushing (Included in Swing Cylinder Assembly)
3	2	82827	Spacer
4	As Req'd	68057	Thrust Washer 1.50"
5	-	82441	Needle Bearing (Included in Swing Cylinder Assembly)
6	2	81022	Swing Cylinder Assembly (Includes (2) #82441 Needle Bearings and (1) #62523 Bushing)
	2	6616	Grease Zerk
	2	30164	Special LH Lateral Tee
7	4	53031	90° Grease Zerk
8	4	82420	Pin
9	4	1047	.38" UNC X 2.00" Hex Capscrew
10	4	1514	.38" Flat Washer
11	4	81595	Spacer Tube
12	4	1837	.38" UNC Hex Lock Nut
13	-	83815	Bushing (Included in Mainframe - Installed with Loctite Grade 680)

MAINFRAME ASSEMBLY

ASSEMBLY #87443

STABILIZERS

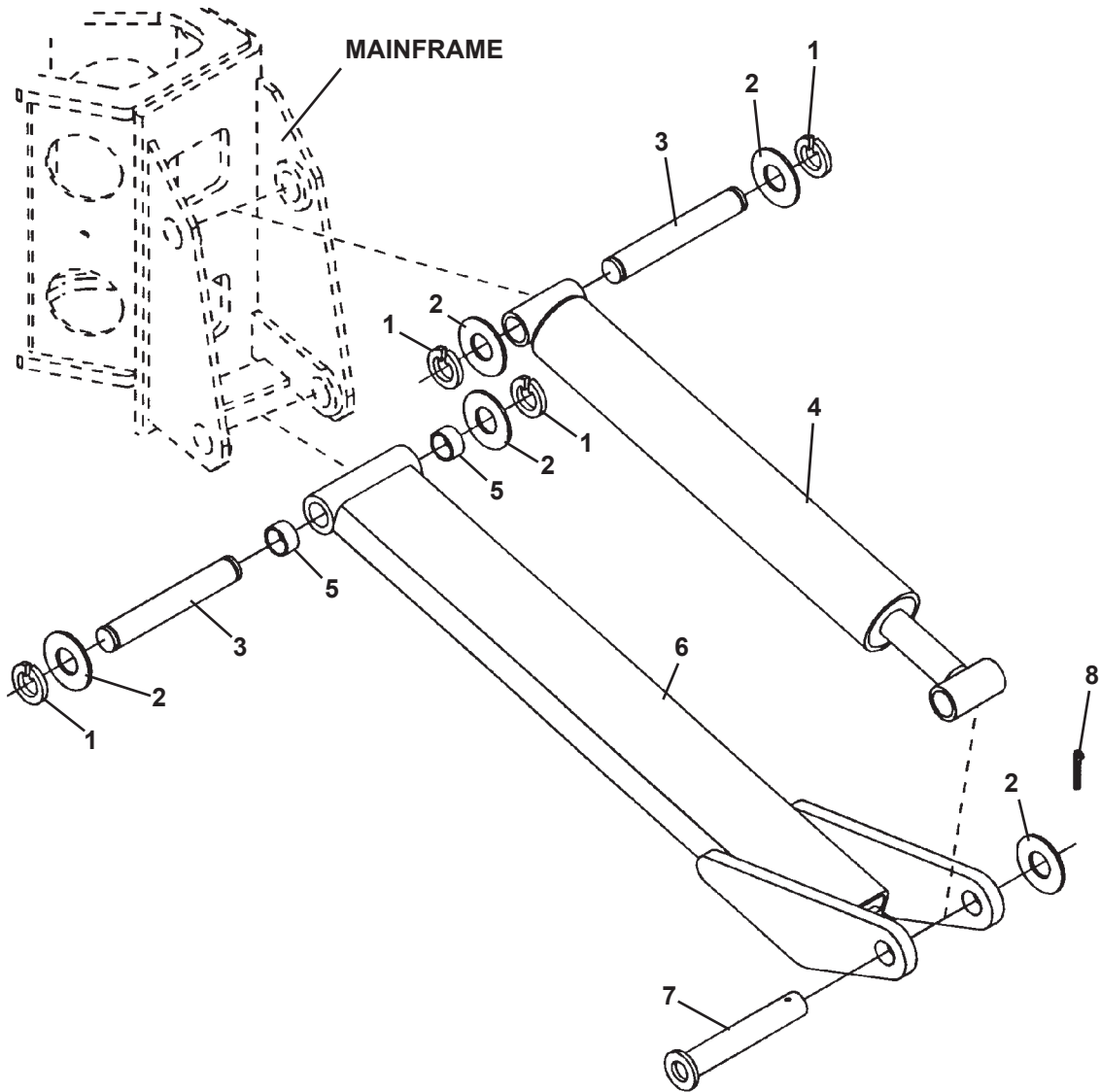

MAINFRAME ASSEMBLY

ASSEMBLY #87443

STABILIZERS

<u>NO</u>	<u>REQ'D</u>	<u>PART NO.</u>	<u>DESCRIPTION</u>
1	8	1652	Snap Ring
2	As Req'd	57693	Thrust Washer 1.25" X .078"
	As Req'd	64727	Thrust Washer 1.25" X .145"
	As Req'd	64728	Thrust Washer 1.25" X .031"
3	4	82993 (1)	Pin
4	2	82980	Stabilizer Cylinder Assembly
	4	6616	Grease Zerk
5	-	82447	Bushing (Included in Mainframe - Installed with Loctite Grade 680)
6	2	82958	Stabilizer Arm
7	2	83233	Pin
8	2	1613	Cotter Pin .25" X 2.00"

NOTE:

- (1) Pivot Pin #82993 is sold only in Pin Kit #86310. Kit includes one pin #82993, two thrust washers #64727 and two snap rings #1652.

HOSE BUNDLE CLAMPS

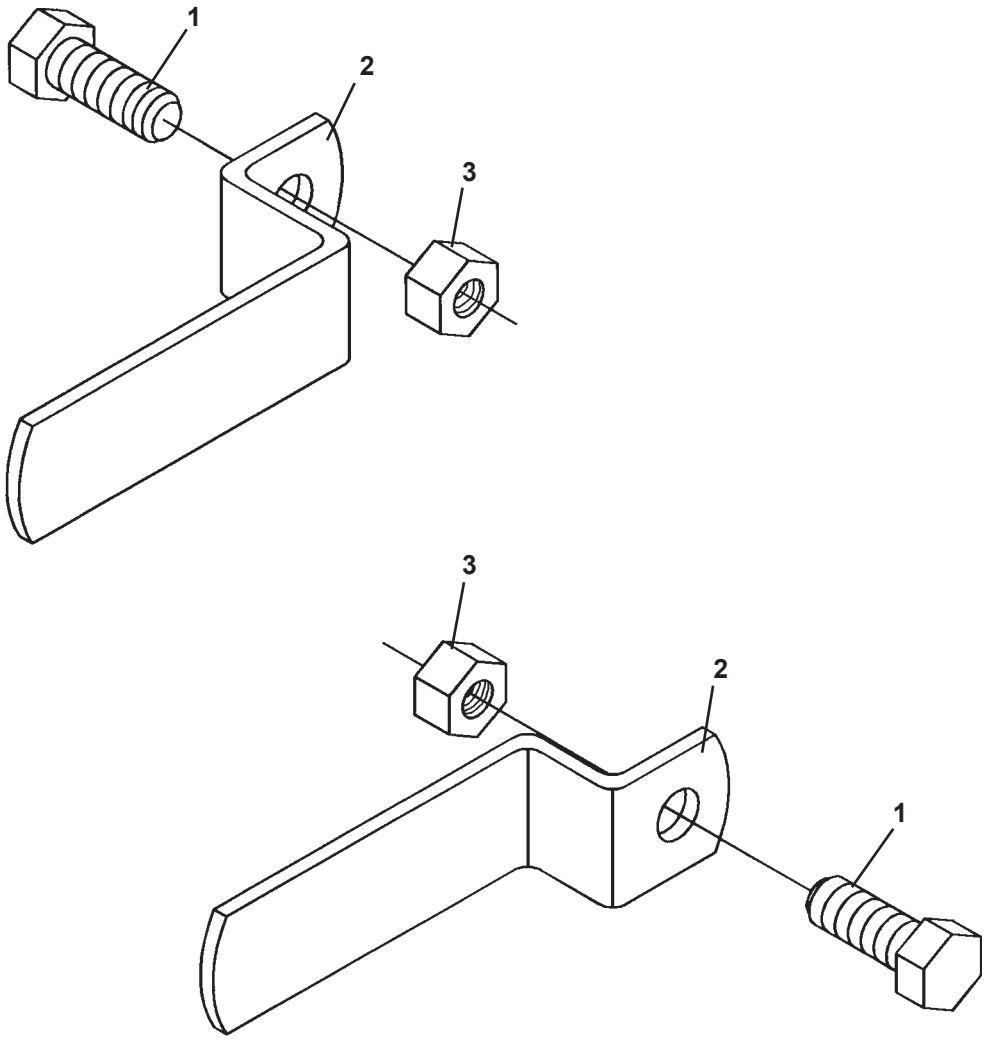

HOSE BUNDLE CLAMPS

UP TO SERIAL #---10065

<u>NO</u>	<u>REQ'D</u>	<u>PART NO.</u>	<u>DESCRIPTION</u>
1	2	1043	.38" UNC X 1.00" Hex Capscrew
2	1	84724	Right Hose Bundle Clamp
3	2	1837	.38" UNC Deformed Lock Nut
4	1	84718	Left Hose Bundle Clamp

SERIAL #---10065 AND UP

<u>NO</u>	<u>REQ'D</u>	<u>PART NO.</u>	<u>DESCRIPTION</u>
1	2	1043	.38" UNC X 1.00" Hex Capscrew
2	1	84718	Right Hose Bundle Clamp
3	2	1837	.38" UNC Deformed Lock Nut
4	1	84718	Left Hose Bundle Clamp

609 BOOM & DIPPER ASSEMBLY

ASSEMBLY #82623

<u>NO</u>	<u>REQ'D</u>	<u>PART NO.</u>	<u>DESCRIPTION</u>
1	-	6615	Self Aligning Bushing (Included in Cylinder Assembly)
2	1	85782	Dipper Cylinder Assembly
	2	6616	Grease Zerk
	2	3103	Straight Adapter
3	As Req'd	6623	Thrust Washer 1.38" X .031"
	As Req'd	64724	Thrust Washer 1.38" X .090"
	As Req'd	64725	Thrust Washer 1.38" X .125"
4	1	82625	Boom Cylinder Assembly
	1	6616	Grease Zerk
	2	3103	Straight Adapter
5	1	1043	.38" UNC X 1.00" Hex Capscrew (Installed with Locktite Grade 242)
6	1	1503	.38" Lock Washer
7	1	82862	Clamp Plate
8	1	82863	Rubber Spacer
9	1	6616	Grease Zerk
10	-	86673	Bushing (Included in Boom Assembly)
11	1	82534 (1)	Pivot Pin
12	4	1650	Snap Ring
13	1	86634 (3)	Boom Lock Handle (Spring Pin Style)
14	1	86366 (3)	Boom Lock (Spring Pin Style)
	1	1972 (3)	Spring Pin
15	1	86048	Boom Assembly (Includes (2) 86673 & (2) 82552 Bushings - Installed with Locktite Grade 680)
16	2	6562	Spring Washer
17	1	1959	.88" UNC Jam Nut
18	1	82535 (2)	Pivot Pin
19	2	82861	Double .50" Hose Clamp
	2	82859	Double .38" Hose Clamp
20	2	1514	.38" Flat Washer
21	2	1837	.38" UNC Deformed Lock Nut
22	1	83656	Handle Grip
23	1	84137	Guide Plate
24	2	1961	.38" UNC X .50" FlangeHead Hex Capscrew
25	1	34120	Hose Sock
26	1	53167	Hose Clamp
27	-	82552	Split Bushing (Included in Boom Assembly)

NOTES:

- (1) Pivot Pin #82534 is sold only in Pin Kit #86309. Kit includes one pin #82534, two thrust washers #6623 and two snap rings #1650.
- (2) Pivot Pin #82535 is sold only in Pin Kit #86307. Kit includes one pin #82535, two thrust washers #6623, two snap rings #1650 and one grease zerk #6616.
- (3) If replacing set screw style boom lock or boom lock handle you must order #86634, #86366 AND #1972.

609 BOOM & DIPPER ASSEMBLY

ASSEMBLY #82623

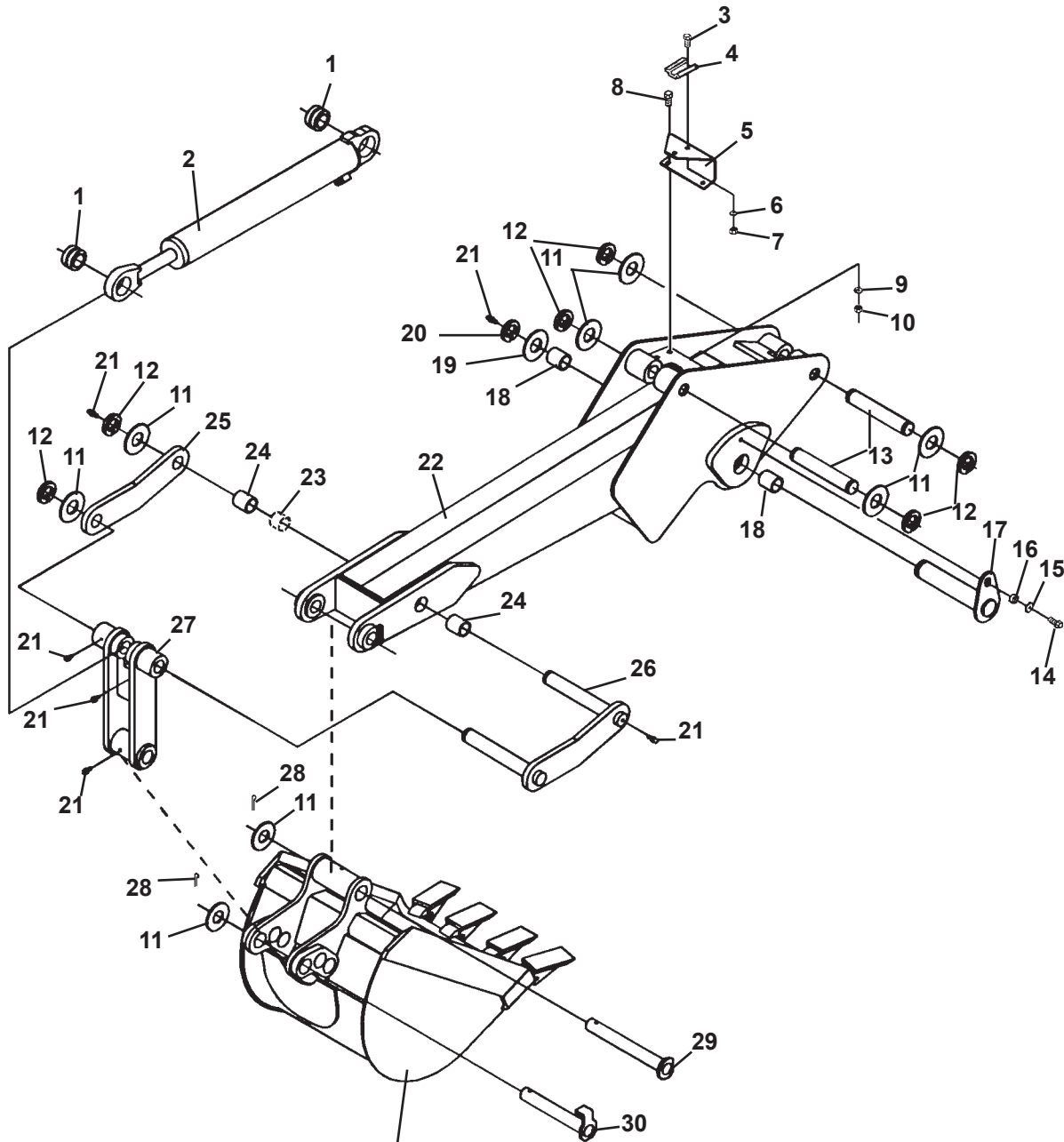

BUCKET
(NOT INCLUDED IN BOOM & DIPPER ASSEMBLY)

609 BOOM & DIPPER ASSEMBLY

ASSEMBLY #82623

<u>NO</u>	<u>REQ'D</u>	<u>PART NO.</u>	<u>DESCRIPTION</u>
1	-	6615	Self Aligning Bushing (Included in Cylinder Assembly)
2	1	117548 (2)	Bucket Cylinder Assembly (SN#314722 and UP)
	2	6616	Grease Zerk
3	2	1021	.31" UNC X .75" Hex Capscrew
4	1	7448	SMV Clip (Used on Tractor Mounted Backhoes ONLY)
5	1	82741	SMV Clip Mounting Plate
6	2	1502	.31" Lock Washer
7	2	1225	.31" UNC Hex Nut
8	2	1043	.38" UNC X 1.00" Hex Capscrew
9	3	1503	.38" Lock Washer
10	2	1226	.38" UNC Hex Nut
11	As Req'd	6623	Thrust Washer 1.38" X .031"
	As Req'd	64724	Thrust Washer 1.38" X .090"
	As Req'd	64725	Thrust Washer 1.38" X .125"
12	6	1650	Snap Ring
13	2	82533 (1)	Pivot Pin
14	1	1088	.50" UNC X 1.00" Hex Capscrew
15	1	1516	.50" Flat Washer
16	1	86149	Spacer Tube
17	1	82416	Pivot Pin
18	-	82402	Bushing (2 Included in Dipper Assembly) (Installed with Locktite Grade 680)
19	As Req'd	6622	Thrust Washer 1.75" X .082
20	1	1651	Snap Ring
21	6	6616	Grease Zerk
22	1	82707	Dipper Assembly (Includes (2) 81610 & (2) 82402 Bushings) (Bushings Installed with Locktite Grade 680)
23	-	83370	Spacer Tube (Used in Dipper UP to SN #---8288)
24	-	81610	Bushing (Included in Dipper Assembly) (Installed with Locktite Grade 680)
25	1	84914	Dipper Link Plate
26	1	83428	Dipper Link
27	1	82523	Bucket Link Assembly (Bucket Link Assembly UP TO SN #---292 Included (2) 81610 Bushings, (4) 81828 Bushings, (1) 83368 Spacer, (2) 83369 Spacers)
28	2	1613	Cotter Pin
29	1	82580	Pivot Pin
30	1	82595	Pivot Pin

NOTE:

- (1) **Pivot Pin #82533 is sold only in Pin Kit #86308. Kit includes one pin #82533, two thrust washers #6623 and two snap rings #1650.**
- (3) **When replacing the bucket cylinder on units up to SN #314721, two #38766 extension hoses must also be ordered.**

611 BOOM & DIPPER ASSEMBLY

ASSEMBLY #82469

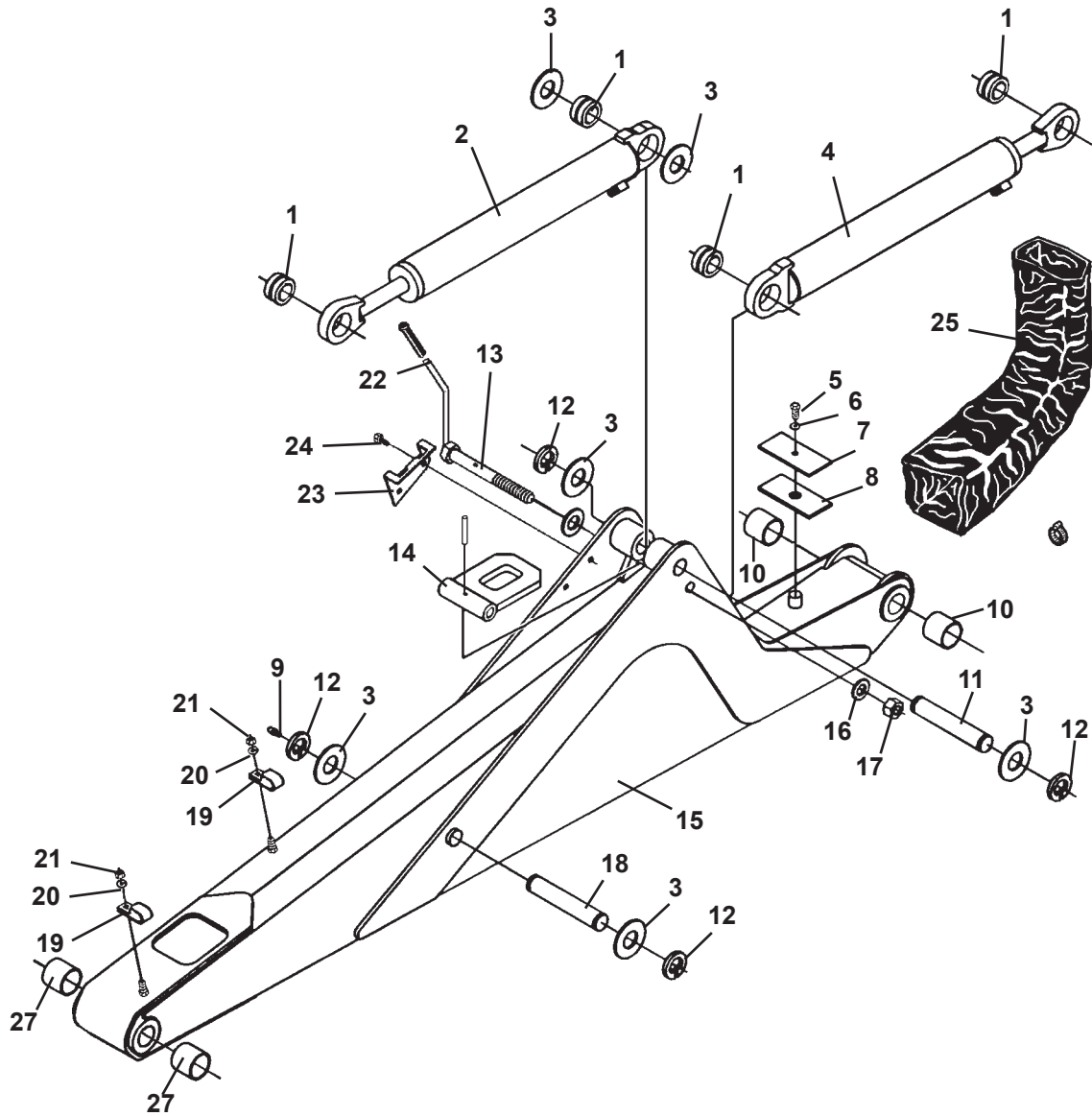

611 BOOM & DIPPER ASSEMBLY

ASSEMBLY #82469

<u>NO</u>	<u>REQ'D</u>	<u>PART NO.</u>	<u>DESCRIPTION</u>
1	-	6615	Self Aligning Bushing (Included in Cylinder Assembly)
2	1	85779	Dipper Cylinder Assembly
	2	6616	Grease Zerk
	2	3103	Straight Adapter
3	As Req'd	6623	Thrust Washer 1.38" X .031"
	As Req'd	64724	Thrust Washer 1.38" X .090"
	As Req'd	64725	Thrust Washer 1.38" X .125"
4	1	82476	Boom Cylinder Assembly
	1	6616	Grease Zerk
	2	3103	Straight Adapter
5	1	1043	.38" UNC X 1.00" Hex Capscrew
6	1	1503	.38" Lock Washer
7	1	82862	Clamp Plate
8	1	82863	Rubber Spacer
9	1	6616	Grease Zerk
10	-	86673	Bushing (Included in Boom Assembly)
11	1	82534 (1)	Pivot Pin
12	4	1650	Snap Ring
13	1	86634 (3)	Boom Lock Handle
14	1	86366 (3)	Boom Lock
	1	1972 (3)	.38" X .50" Set Screw
15	1	82677	Boom Assembly (Includes (2) 82552 & (2) 86673 Bushings - Installed with Locktite Grade 680)
16	2	6562	Spring Washer
17	1	1959	.88" UNC Jam Nut
18	1	82535 (2)	Pivot Pin
19	2	82859	Double Hose Clamp
20	2	1514	.38" Flat Washer
21	2	1837	.38" UNC Deformed Lock Nut
22	1	83656	Handle Grip
23	1	84137	Guide Plate
24	2	1961	.38" UNC X .50" Flange Head Hex Capscrew
25	1	34120	Hose Sock
26	1	53167	Hose Clamp
27	-	82552	Bushing (Included in Boom Assembly)

NOTES:

- (1) Pivot Pin #82534 is sold only in Pin Kit #86309. Kit includes one pin #82534, two thrust washers #6623 and two snap rings #1650.
- (2) Pivot Pin #82535 is sold only in Pin Kit #86307. Kit includes one pin #82535, two thrust washers #6623, two snap rings #1650 and one grease zerk #6616.
- (3) If replacing set screw style boom lock or boom lock handle you must order #86634, #86366 AND #1972.

611 BOOM & DIPPER ASSEMBLY

ASSEMBLY #82469

<u>NO</u>	<u>REQ'D</u>	<u>PART NO.</u>	<u>DESCRIPTION</u>
1	-	6615	Self Aligning Bushing (Included in Cylinder Assembly)
2	1	117548 (2)	Bucket Cylinder Assembly (SN#315228 and UP)
	2	6616	Grease Zerk
3	2	1021	.31" UNC X .75" Hex Capscrew
4	1	7448	SMV Clip (Used on Tractor Mounted Backhoes ONLY)
5	1	82741	SMV Clip Mounting Plate
6	2	1502	.31" Lock Washer
7	2	1225	.31" UNC Hex Nut
8	2	1043	.38" UNC X 1.00" Hex Capscrew
9	2	1503	.38" Lock Washer
10	2	1226	.38" UNC Hex Nut
11	As Req'd	6623	Thrust Washer 1.38" X .031"
	As Req'd	64724	Thrust Washer 1.38" X .090"
	As Req'd	64725	Thrust Washer 1.38" X .125"
12	6	1650	Snap Ring
13	2	82533 (1)	Pivot Pin
14	1	1088	.50" UNC X 1.00" Hex Capscrew
15	1	1516	.50" Flat Washer
16	1	86149	Spacer Tube
17	1	82416	Pivot Pin
18	-	82402	Bushing (2 Included in Dipper Assembly) (Installed with Locktite Grade 680)
19	As Req'd	6622	Thrust Washer 1.75" X .082
20	1	1651	Snap Ring
21	6	6616	Grease Zerk
22	1	82682	Dipper Assembly (Includes (2) 81610 & (2) 82402 Bushings) (Bushings Installed with Locktite Grade 680)
23	-	83370	Spacer Tube (Used in Dipper UP to SN #---8226)
24	-	81610	Bushing (Included in Dipper Assembly) (Installed with Locktite Grade 680)
25	1	84914	Dipper Link Plate
26	1	83428	Dipper Link
27	1	82523	Bucket Link Assembly (Bucket Link Assembly UP TO SN #---292 Included (2) 81610 Bushings, (4) 81828 Bushings, (1) 83368 Spacer, (2) 83369 Spacers)
28	2	1613	Cotter Pin
29	1	82580	Pivot Pin
30	1	82595	Pivot Pin

NOTE:

- (1) **Pivot Pin #82533 is sold only in Pin Kit #86308. Kit includes one pin #82533, two thrust washers #6623 and two snap rings #1650.**
- (2) **When replacing the bucket cylinder on units up to SN #315227, two #38766 extension hoses must also be ordered.**

CONSOLE ASSEMBLY

ASSEMBLY #87442

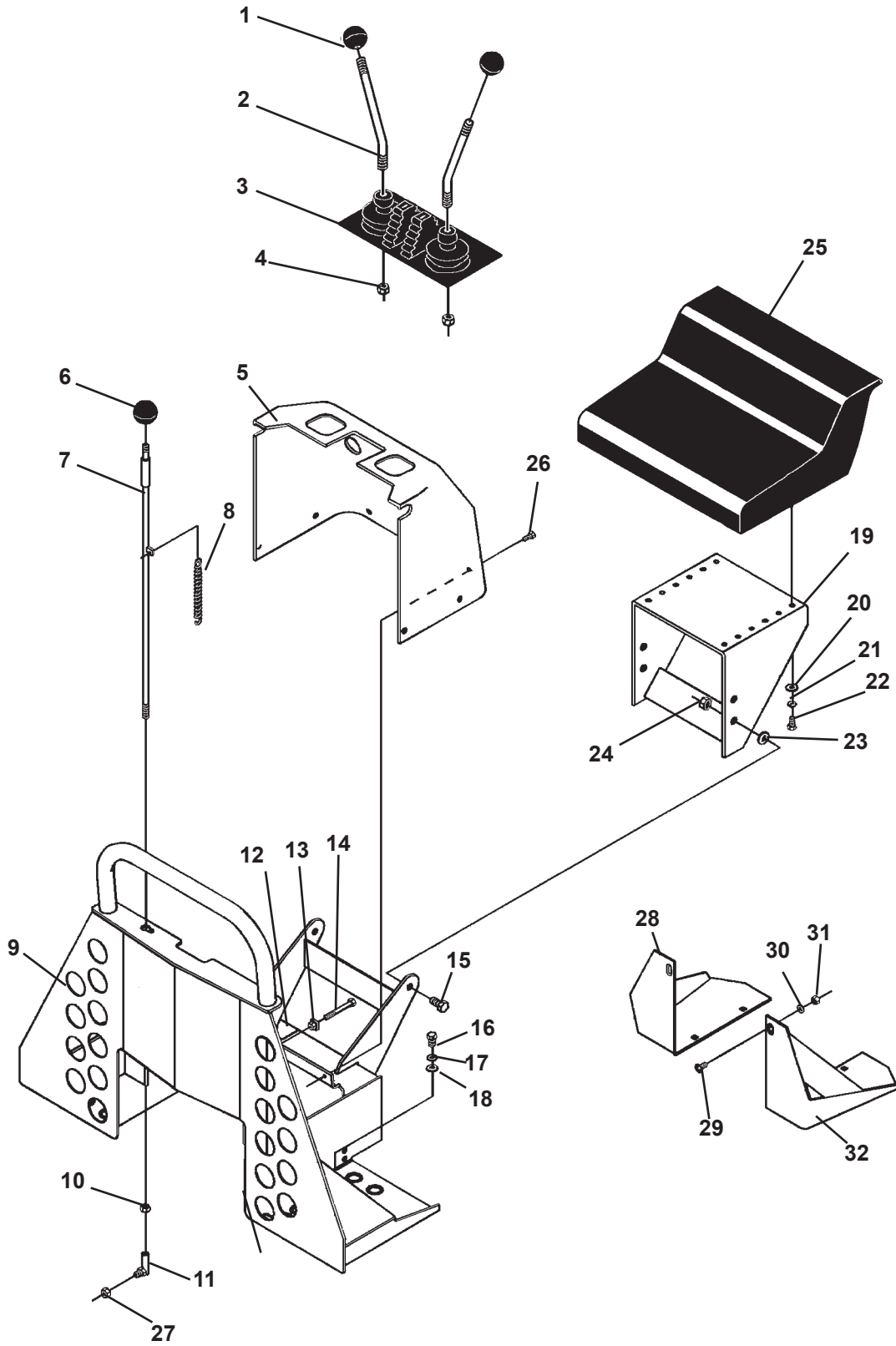

CONSOLE ASSEMBLY

ASSEMBLY #87442

<u>ITEM</u>	<u>REQ'D</u>	<u>PART NO.</u>	<u>DESCRIPTION</u>
1	2	83063	Ball Handle
2	2	81871	Control Handle
3	1	83235	Control Lever Boot
4	2	1242	.50" UNC Jam Nut
5	1	83409	Console Cover with Decals
6	1	83406	Ball Handle - RED
7	1	83273	Rod
8	1	82795	Spring
9	1	87288	Console
10	1	1476	.38-24" UNF Jam Nut
11	1	5545	Balljoint
12	1	87147	Cover Plate
	2	1958	.25" UNC X .75" Hex Head Body Bolt
13	3	1926	.31" UNC U-Nut
14	3	1029	.31" UNC X 2.75" Hex Capscrew
15	2	1089	.50" UNC X 1.25" Hex Capscrew
16	4	1042	.38" UNC X .75" Hex Capscrew
17	4	1503	.38" Lock Washer
18	4	1514	.38" Flat Washer
19	1	82999	Seat Mounting
20	4	1513	.31" Flat Washer
21	4	1502	.31" Lock Washer
22	4	1021	.31" UNC X .75" Hex Capscrew
23	2	1516	.50" Flat Washer
24	2	1542	.50" UNC Lock Nut
25	1	6980	Seat
26	6	1958	.25" UNC X .75" Hex Head Body Bolt
27	1	1592	.38" UNF Lock Nut

Replacement Bolt-On Steps for units built before June 1, 1999

28	1	82818	Right Step (Located in Mainframe Assembly)
29	6	1925	.31" UNC X .75" Carriage Bolt
30	6	1502	.31" Lock Washer
31	6	1225	.31" UNC Hex Nut
32	1	82819	Left Step (Located in Mainframe Assembly)

VALVE ASSEMBLY

ASSEMBLY #2232

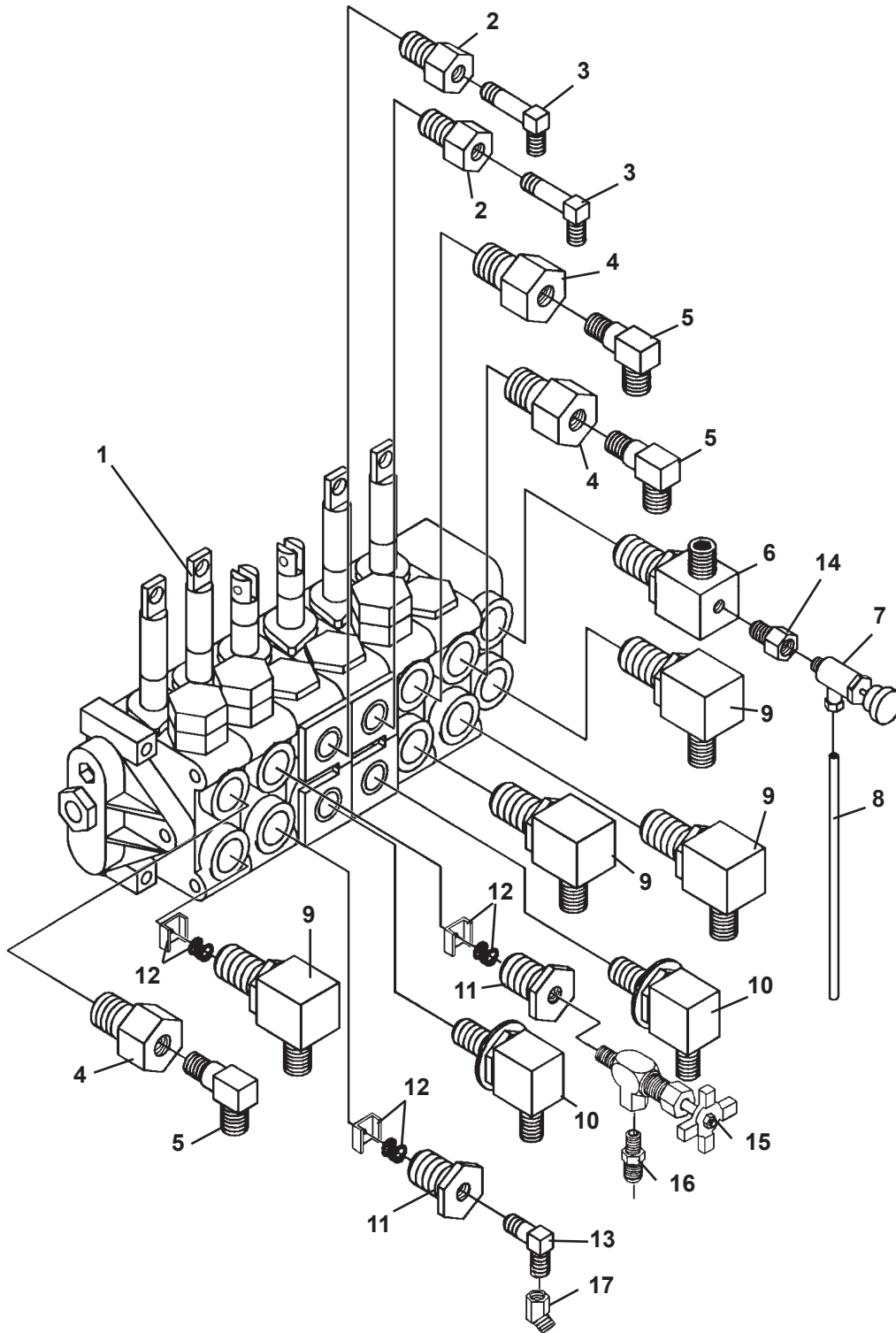

VALVE ASSEMBLY

ASSEMBLY #2232

<u>NO</u>	<u>REQ'D</u>	<u>PART NO.</u>	<u>DESCRIPTION</u>
1	1	82608	Valve - 6 Spool - Gresen
2	2	3368	O'Ring Adapter 8MBo-4FP
3	2	3088	90° Adapter 4MP-6MJ Long
4	3	3487	O'Ring Adapter 10MBo-6FP
5	3	3180	90° Adapter 6MP-8MJ
6	1	82094	Special Fitting
7	1	3360	Needle Valve
8	1	37578	Plastic Tube .25" X 30" (Located in Console Assembly)
9	4	3283	90° Adapter 10MBo-8MJ
10	2	30142	90° SAE O'Ring Boss 8MBo-6MJ
11	2	3336	O'Ring Adapter 10MBo-4FP
12	-	45643	Restrictor with Spring - .109 Dia. Orifice (Included in Valve)
13	1	3001	90° Adapter 4MP-6MJ
14	1	30151	Straight Adapter (If Required to Extend Needle Valve Through Console)
15	1	3185	Needle Valve
16	1	3137	Male Connector 4MP-6MJ
17	1	3469	45° Elbow 6MJ-6FJX (Located in Mainframe Assembly & Used on Backhoes with SN#10067 & UP)

VALVE ASSEMBLY

GRESEN VALVE ASSEMBLY

609 & 611 BACKHOE (509 & 511 BACKHOES UP TO SN #270215)

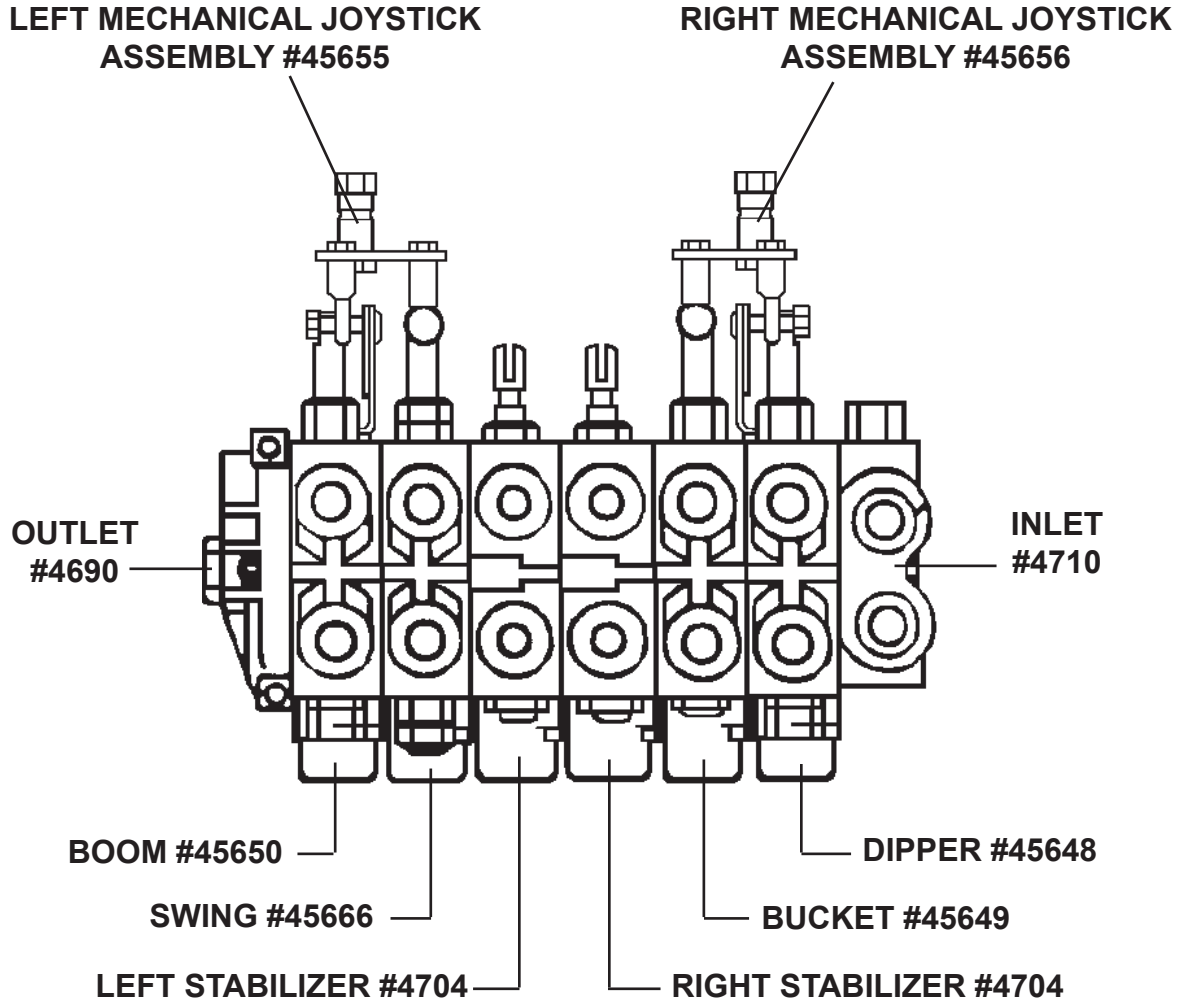

VALVE ASSEMBLY

GRESEN INLET COVER

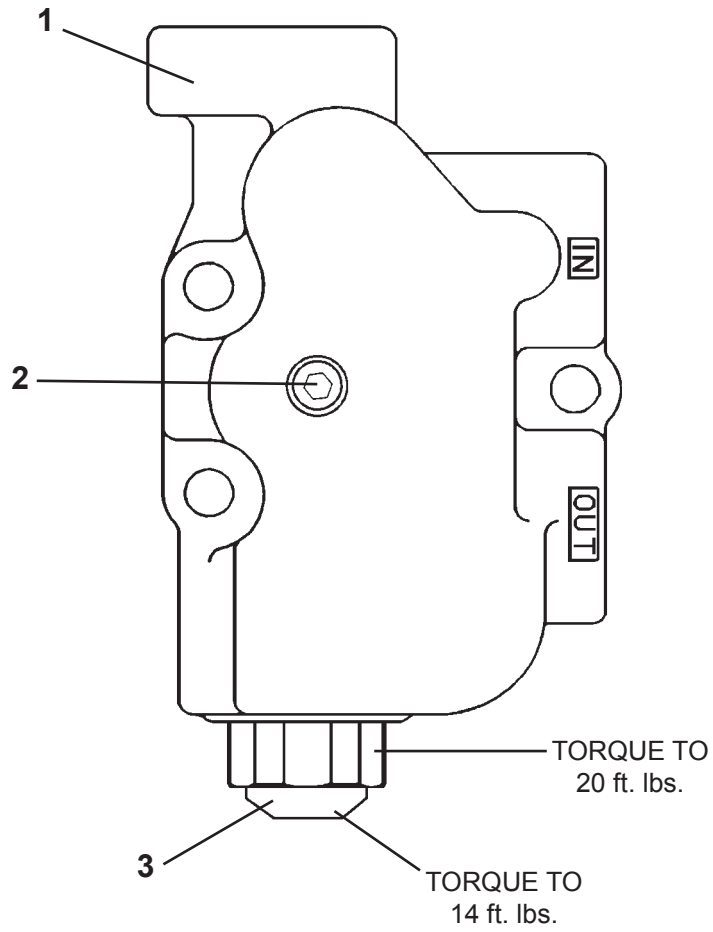

VALVE ASSEMBLY
GRESEN INLET COVER

<u>ITEM</u>	<u>REQ'D</u>	<u>PART NO.</u>	<u>DESCRIPTION</u>
1	1	4710	Inlet Cover #10 Ports
2	1	3156	Plug
3	1	45625	WH Main Relief Valve Assembly @ 2500 PSI

VALVE ASSEMBLY

GRESEN VALVE SECTION ASSEMBLY #45648

408 Dipper & Bucket Section

509, 511, 609, & 611 Dipper Section

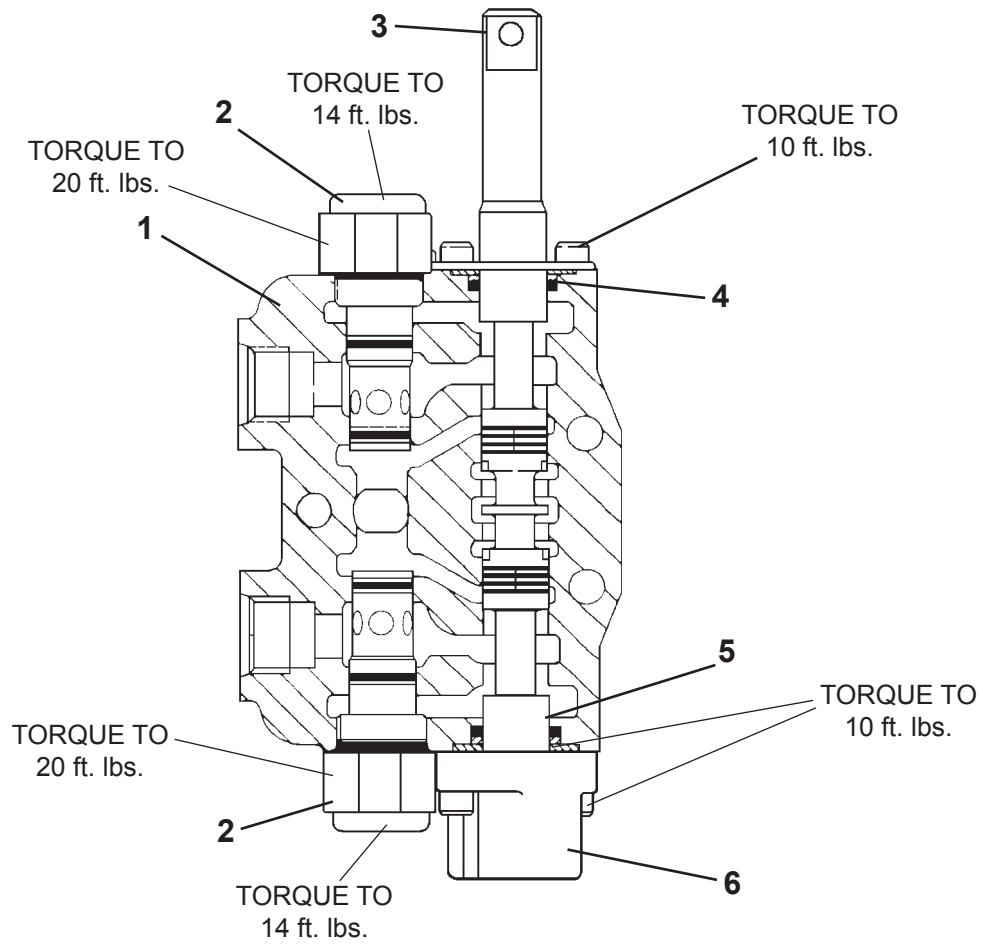

VALVE ASSEMBLY

GRESEN VALVE SECTION ASSEMBLY #45648

408 Dipper & Bucket Section

509, 511, 609, & 611 Dipper Section

<u>ITEM</u>	<u>REQ'D</u>	<u>PART NO.</u>	<u>DESCRIPTION</u>
1	1		Valve Section Housing
2	2	45667	Cylinder Port Relief Assembly @ 2500 PSI
3	1	45653	Spool Clevis Adapter
4	2	45652	Spool Seal Kit
5	1		Spool
6	1	45282	Spool Positioner Assembly

INCLUDED IN VALVE ASSEMBLY BUT NOT IN VALVE SECTION

1		45546	Restrictor with Spring - .095 Dia. Orifice (Used in 408 Dipper Section - Top Port)
1		45633	Restrictor with Spring - .076 Dia. Orifice (Used in 408 Bucket Section - Bottom Port)

NOTES:

Items without part numbers are not sold separately.

Valve Section Seal Kit #4653 contains (3) Exhaust Passage O-Ring Seals and
2) Pressure Passage O-Ring Seals.

Complete Section Service Seal Kit #4719 includes ALL seals needed to service one
complete valve section.

VALVE ASSEMBLY

GRESEN VALVE SECTION ASSEMBLY #45649
509, 511, 609, & 611 Bucket Section

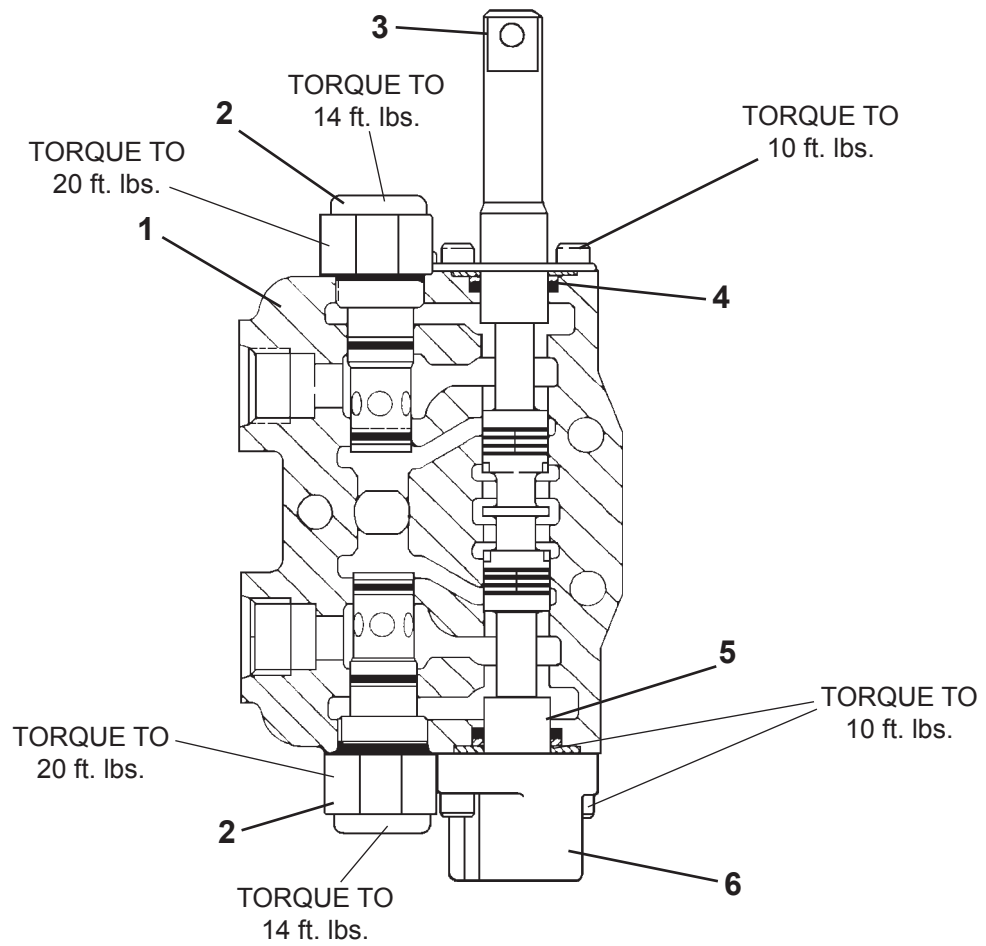

VALVE ASSEMBLY

GRESEN VALVE SECTION ASSEMBLY #45649

509, 511, 609, & 611 Bucket Section

<u>ITEM</u>	<u>REQ'D</u>	<u>PART NO.</u>	<u>DESCRIPTION</u>
1	1		Valve Section Housing
2	1	45669	Cylinder Port Relief Assembly @ 3500 PSI
3	1	45653	Spool Clevis Adapter
4	2	45652	Spool Seal Kit
5	1		Spool
6	1	45282	Spool Positioner Assembly
7	1	4673	Load Check Plug Assembly

NOTES:

Items without part numbers are not sold separately.

Valve Section Seal Kit #4653 contains (3) Exhaust Passage O-Ring Seals and (2) Pressure Passage O-Ring Seals.

Complete Section Service Seal Kit #4719 includes ALL seals needed to service one complete valve section.

VALVE ASSEMBLY
GRESEN VALVE STABILIZER SECTION
ASSEMBLY #4704

Horizontal Handle Assembly #45586
(Not included in Valve Section Assembly #4704)

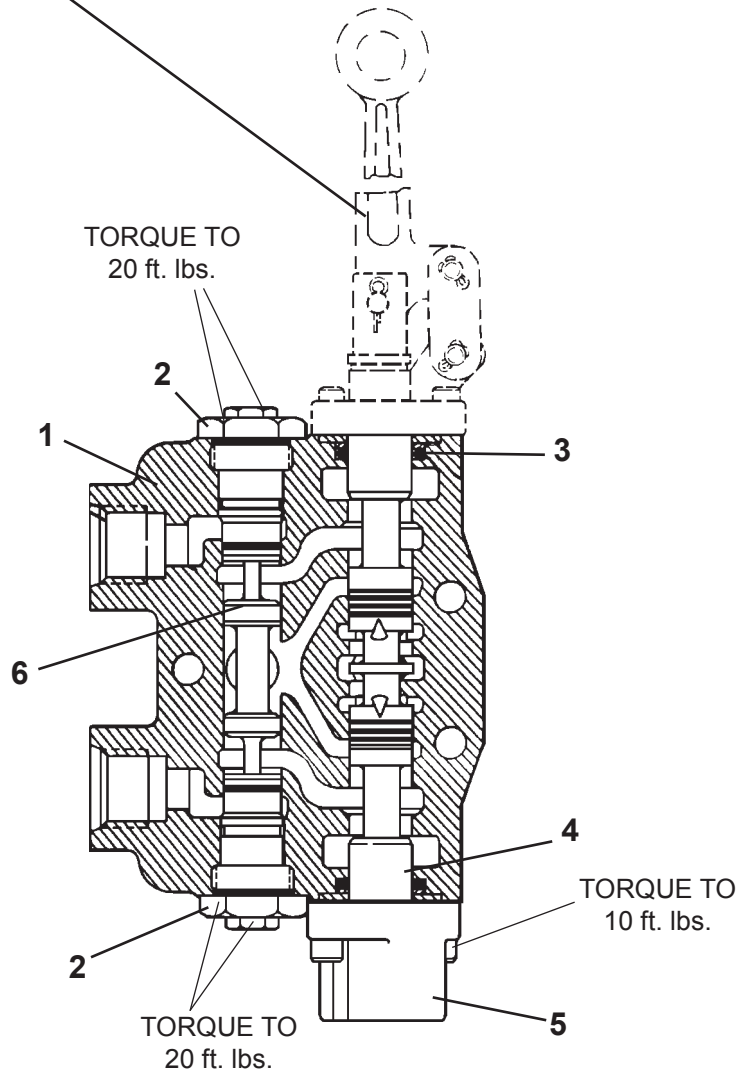

VALVE ASSEMBLY
GRESEN VALVE STABILIZER SECTION
ASSEMBLY #4704

<u>ITEM</u>	<u>REQ'D</u>	<u>PART NO.</u>	<u>DESCRIPTION</u>
1	1		Valve Section Housing
2	2	4819	Lockout Check Assembly
3	2	45652	Spool Seal Kit
4	1		Spool
5	1	45282	Spool Positioner Assembly
6	1	45654	Unlocking Piston

NOTES:

Items without part numbers are not sold separately.

Valve Section Seal Kit #4653 contains (3) Exhaust Passage O-Ring Seals and (2) Pressure Passage O-Ring Seals.

Complete Section Service Seal Kit #4719 includes ALL seals needed to service one complete valve section.

VALVE ASSEMBLY

GRESEN VALVE SECTION ASSEMBLY #45666
509, 511, 609, & 611 Swing Section

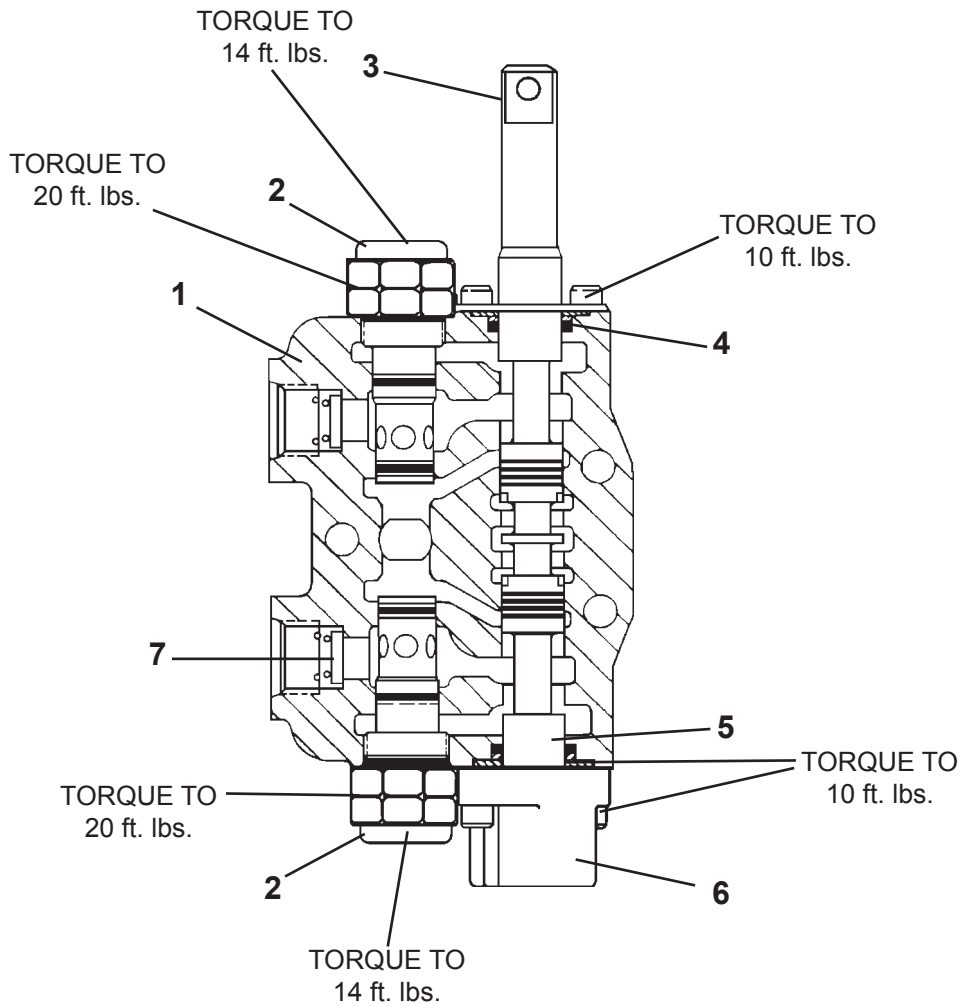

VALVE ASSEMBLY

GRESEN VALVE SECTION ASSEMBLY #45666

509, 511, 609, & 611 Swing Section

<u>ITEM</u>	<u>REQ'D</u>	<u>PART NO.</u>	<u>DESCRIPTION</u>
1	1		Valve Section Housing
2	2	45670	Cylinder Port Relief / Anti-Cav. Check Assembly @ 2500 PSI
3	1	45653	Spool Clevis Adapter
4	2	45652	Spool Seal Kit
5	1		Spool
6	1	45282	Spool Positioner Assembly
7	2	45633	Port Restrictor with Spring .076 Dia. Orifice

NOTES:

Items without part numbers are not sold separately.

Valve Section Seal Kit #4653 contains (3) Exhaust Passage O-Ring Seals and (2) Pressure Passage O-Ring Seals.

Complete Section Service Seal Kit #4719 includes ALL seals needed to service one complete valve section.

VALVE ASSEMBLY

GRESEN VALVE SECTION ASSEMBLY #45650
509, 511, 609, & 611 Boom Section

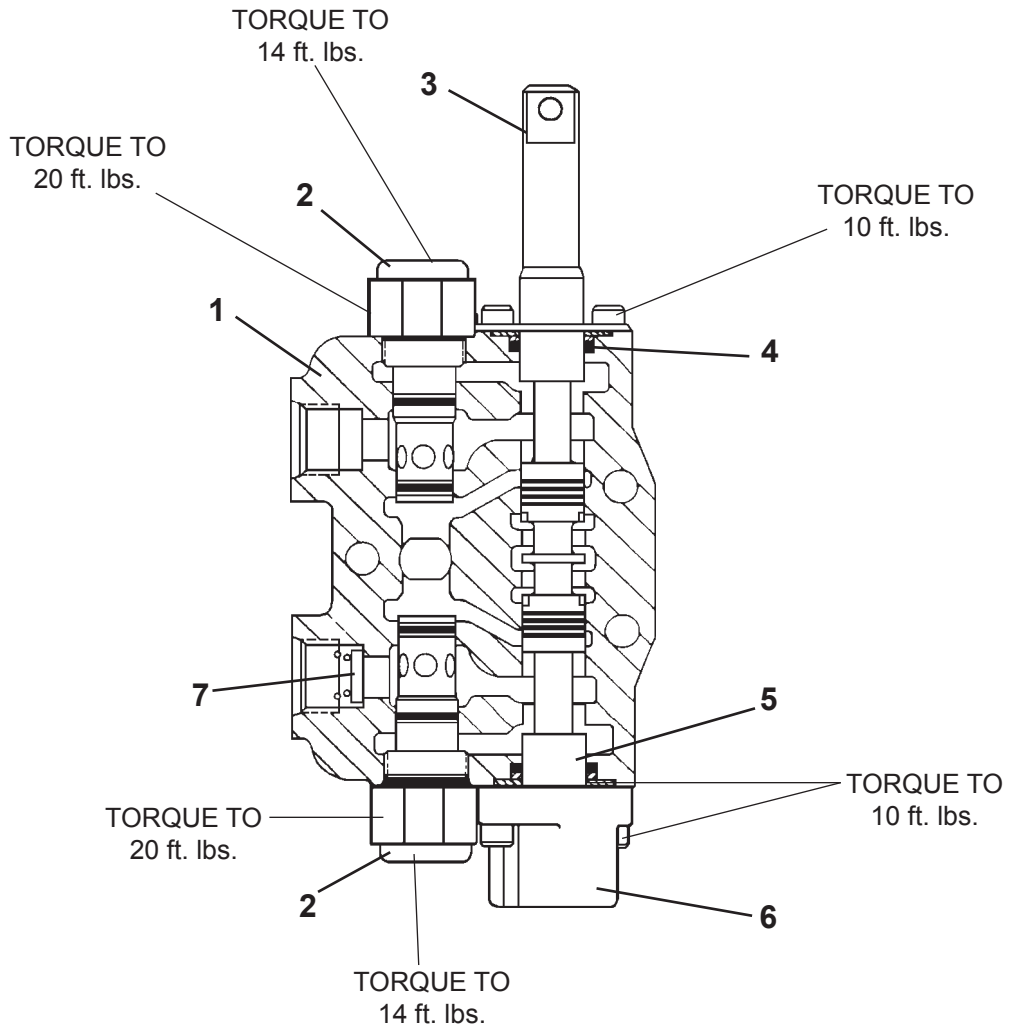

VALVE ASSEMBLY

GRESEN VALVE SECTION ASSEMBLY #45650

509, 511, 609, & 611 Boom Section

<u>ITEM</u>	<u>REQ'D</u>	<u>PART NO.</u>	<u>DESCRIPTION</u>
1	1		Valve Section Housing
2	2	45668	Cylinder Port Relief Assembly @ 3000 PSI
3	1	45653	Spool Clevis Adapter
4	2	45652	Spool Seal Kit
5	1		Spool
6	1	45282	Spool Positioner Assembly
7	2	45643	Port Restrictor with Spring .109 Dia. Orifice

NOTES:

Items without part numbers are not sold separately.

Valve Section Seal Kit #4653 contains (3) Exhaust Passage O-Ring Seals and (2) Pressure Passage O-Ring Seals.

Complete Section Service Seal Kit #4719 includes ALL seals needed to service one complete valve section.

VALVE ASSEMBLY

GRESEN OUTLET COVER

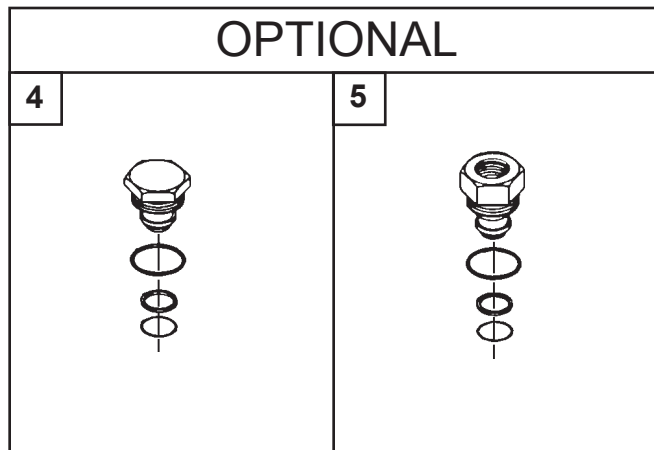
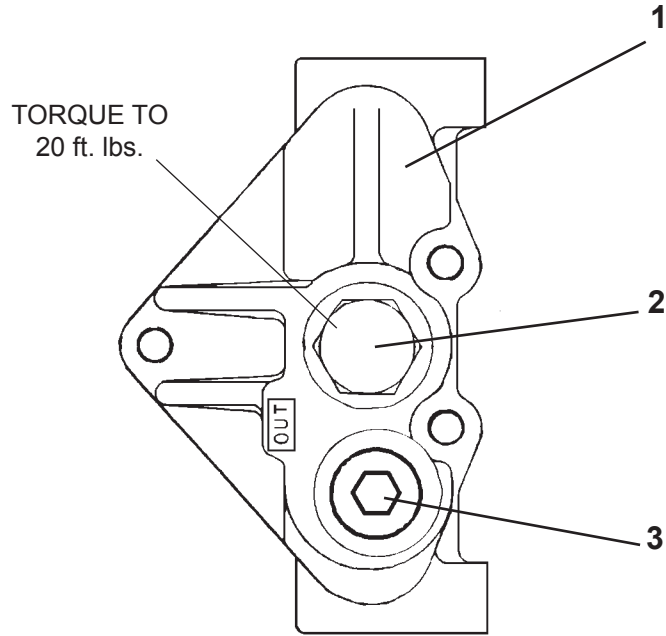

TORQUE TO 20 ft. lbs.

VALVE ASSEMBLY

GRESEN OUTLET COVER

<u>ITEM</u>	<u>REQ'D</u>	<u>PART NO.</u>	<u>DESCRIPTION</u>
1	1	4690	Outlet Cover
2	1	4691	Open Center Plug Assembly (Includes Open Center Plug & Main O-Ring Seal #4693)
3	1	3234	Plug

OPTIONAL

4	-	6977	Closed Center Plug Assembly (Includes Main O-Ring Seal #4693)
5	-	4698	Power Beyond Sleeve Assembly (Includes Main O-Ring Seal #4693)

NOTES:

Valve Section Seal Kit #4653 contains (3) Exhaust Passage O-Ring Seals and (2) Pressure Passage O-Ring Seals.

VALVE ASSEMBLY

LEFT MECHANICAL JOYSTICK ASSEMBLY #45655

RIGHT MECHANICAL JOYSTICK ASSEMBLY #45656

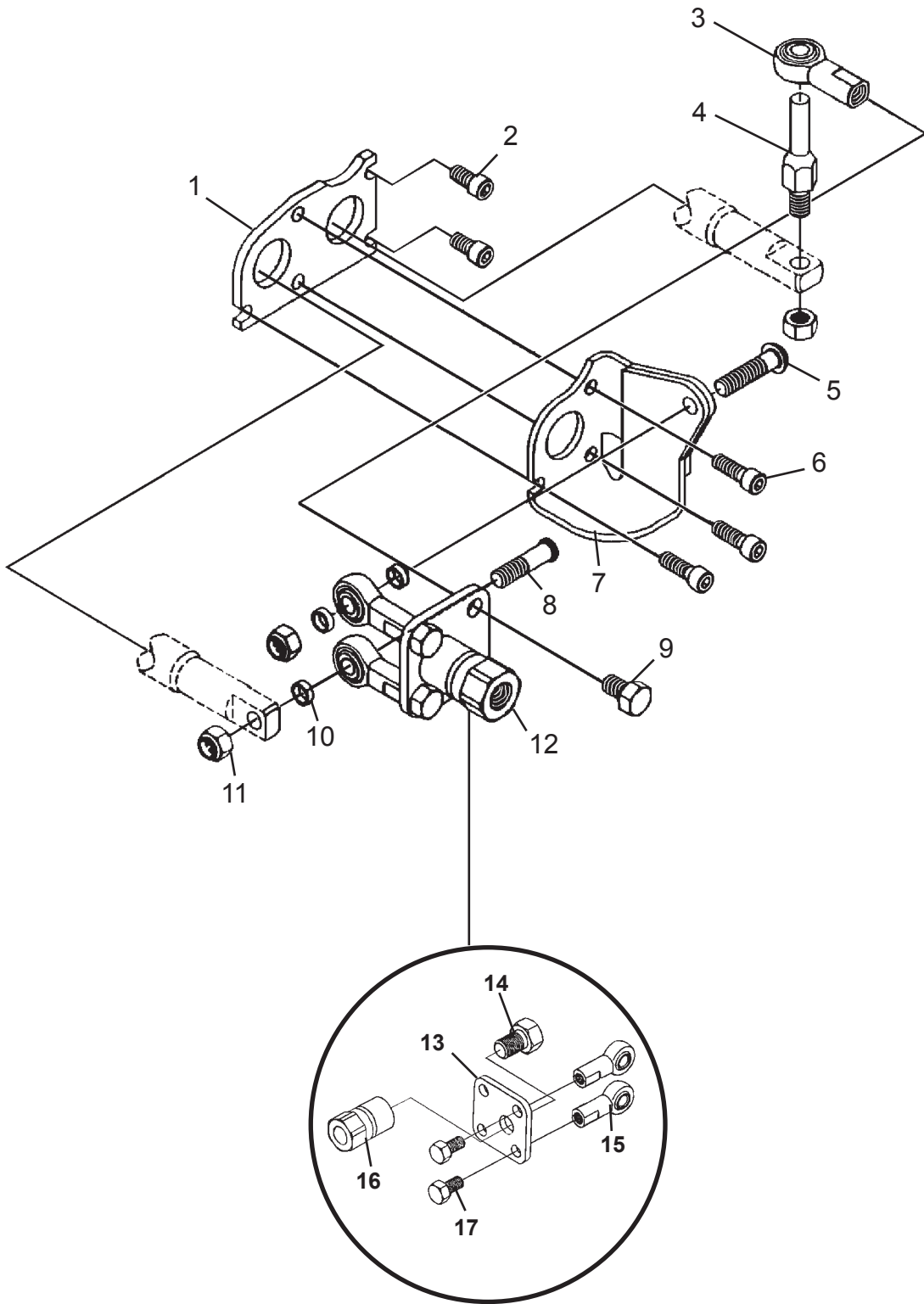

VALVE ASSEMBLY

LEFT MECHANICAL JOYSTICK ASSEMBLY #45655
RIGHT MECHANICAL JOYSTICK ASSEMBLY #45656

<u>ITEM</u>	<u>REQ'D</u>	<u>PART NO.</u>	<u>DESCRIPTION</u>
1	1	45657	Mounting Plate
2	2	1943	Screw
3	1	45664	Rod End
4	1	45662	Mechanical Slide
5	1	1945	Screw
6	3	1944	Screw
7	1	45658	Bracket - Left
	1	45659	Bracket - Right
8	1	45661	Rod End Stud
9	1	1271	Screw
10	3	45660	Spacer
11	3	1942	Lock Nut
12	1	45663	Handle Plate Assembly (Includes Items #13 through #17)
13	1	45671	Mechanical Joystick Plate
14	1	1087	Screw
15	2	45664	Female Rod End
16	1	45672	Handle Adapter
17	2	1271	Screw

VALVE ASSEMBLY

HORIZONTAL HANDLE AND BRACKET ASSEMBLY #45586

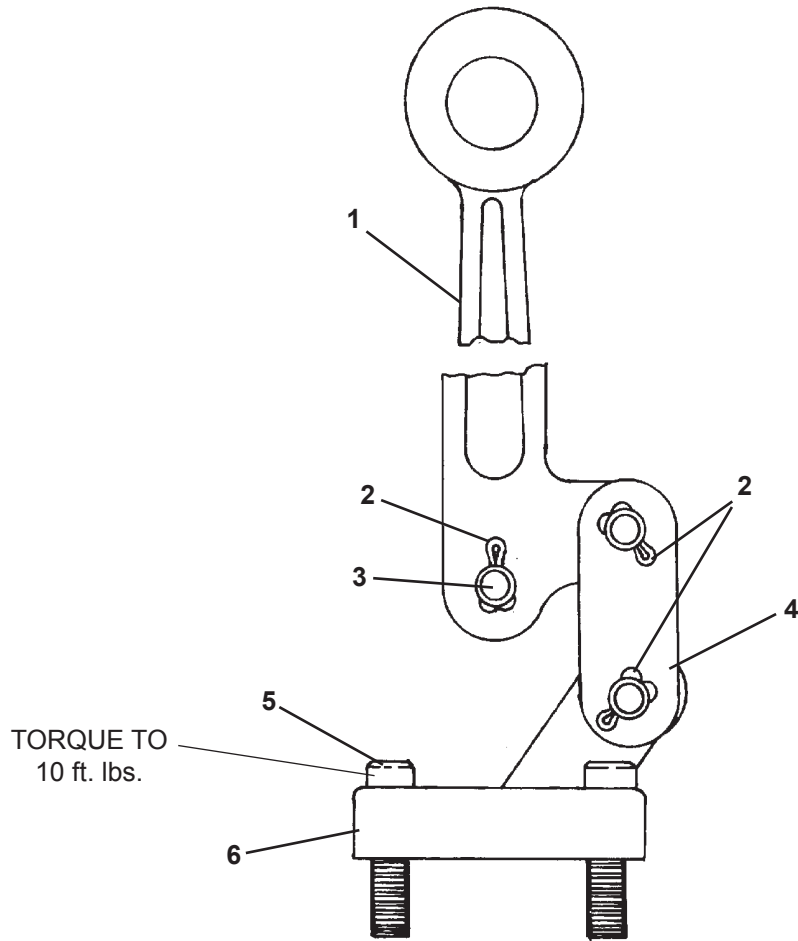

VALVE ASSEMBLY

HORIZONTAL HANDLE AND BRACKET ASSEMBLY #45586

<u>ITEM</u>	<u>REQ'D</u>	<u>PART NO.</u>	<u>DESCRIPTION</u>
1	1	*	Handle
2	3	*	Cotter Pin
3	1	*	Pin
4	1	*	Link
	1	*	Link Plate
5	2	*	Screw
6	1	*	Bracket

* **NOTE: All parts marked with an asterisk (*) are included in Horizontal Handle and Bracket Assembly #45586. Parts are not sold separately.**

VALVE ASSEMBLY

GRESEN VALVE SERVICE PARTS

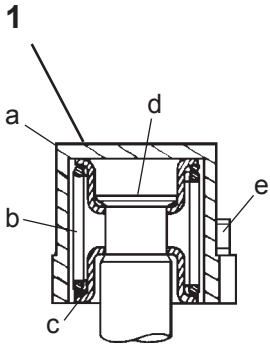

Spool Positioner Assembly

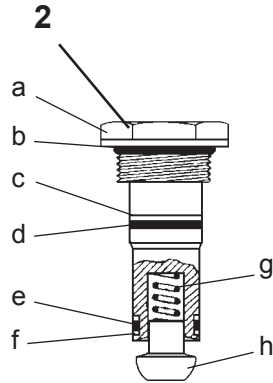

Load Check Plug Assembly

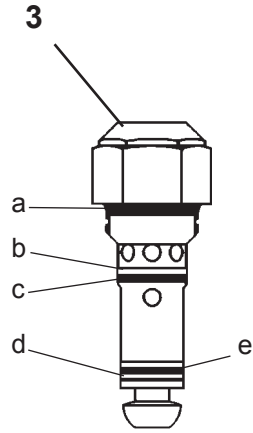

Cylinder Port Relief Assembly

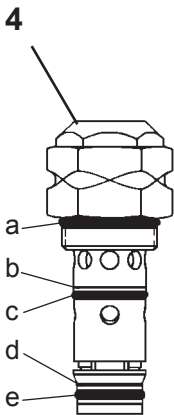

Cylinder Port Relief Assembly

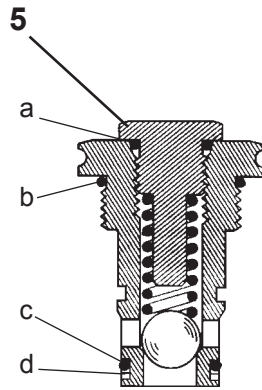

Lockout Check Assembly

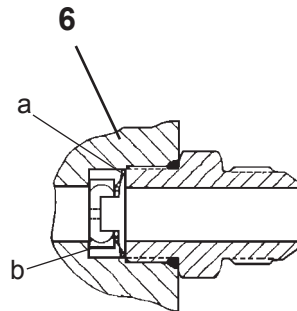

Port Restrictor and Spring Assembly

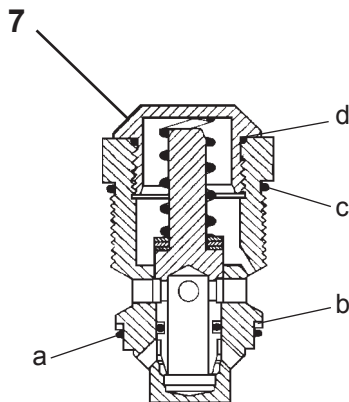

WH Main Relief Valve Assembly

VALVE ASSEMBLY

GRESEN VALVE SERVICE PARTS

<u>NO</u>	<u>PART NO.</u>	<u>DESCRIPTION</u>
1	45282	Spool Positioner Assembly a Bonnet b Spring c Spring Collar d Spool Spud e Screw
2	4673	Load Check Plug Assembly (Seal Kit #4822) a Plug b O-Ring Seal c Backup Ring d O-Ring Seal e Backup Ring f O-Ring Seal g Spring h Poppet
3	45667 45668 45669	Cylinder Port Relief Assembly @ 2500 PSI Cylinder Port Relief Assembly @ 3000 PSI Cylinder Port Relief Assembly @ 3500 PSI (Due to close tolerances only the seals may be serviced in the field.) 4822 Seal Kit a O-Ring Seal b Backup Ring c O-Ring Seal d Backup Ring e O-Ring Seal
4	45670	Relief/Anti-Cav. Check Assembly @ 2500 PSI (Due to close tolerances only the seals may be serviced in the field.) 4822 Seal Kit a O-Ring Seal b Backup Ring c O-Ring Seal d Backup Ring e O-Ring Seal
5	4819	Lockout Check Assembly (Due to close tolerances only the seals may be serviced in the field.) 4829 Seal Kit a O-Ring Seal b Backup Ring c O-Ring Seal d Backup Ring
6	45633 45643	Port Restrictor Assembly .076 Dia. Orifice Port Restrictor Assembly .109 Dia. Orifice a Spring b Orifice Plate
7	45625	WH Main Relief Valve Assembly @ 2500 PSI (Due to close tolerances only the seals may be serviced in the field.) 45142 Seal Kit a O-Ring Seal b Backup Ring c O-Ring Seal d O-Ring Seal

OPTIONAL SWING SPEED CONTROL

ASSEMBLY #83337

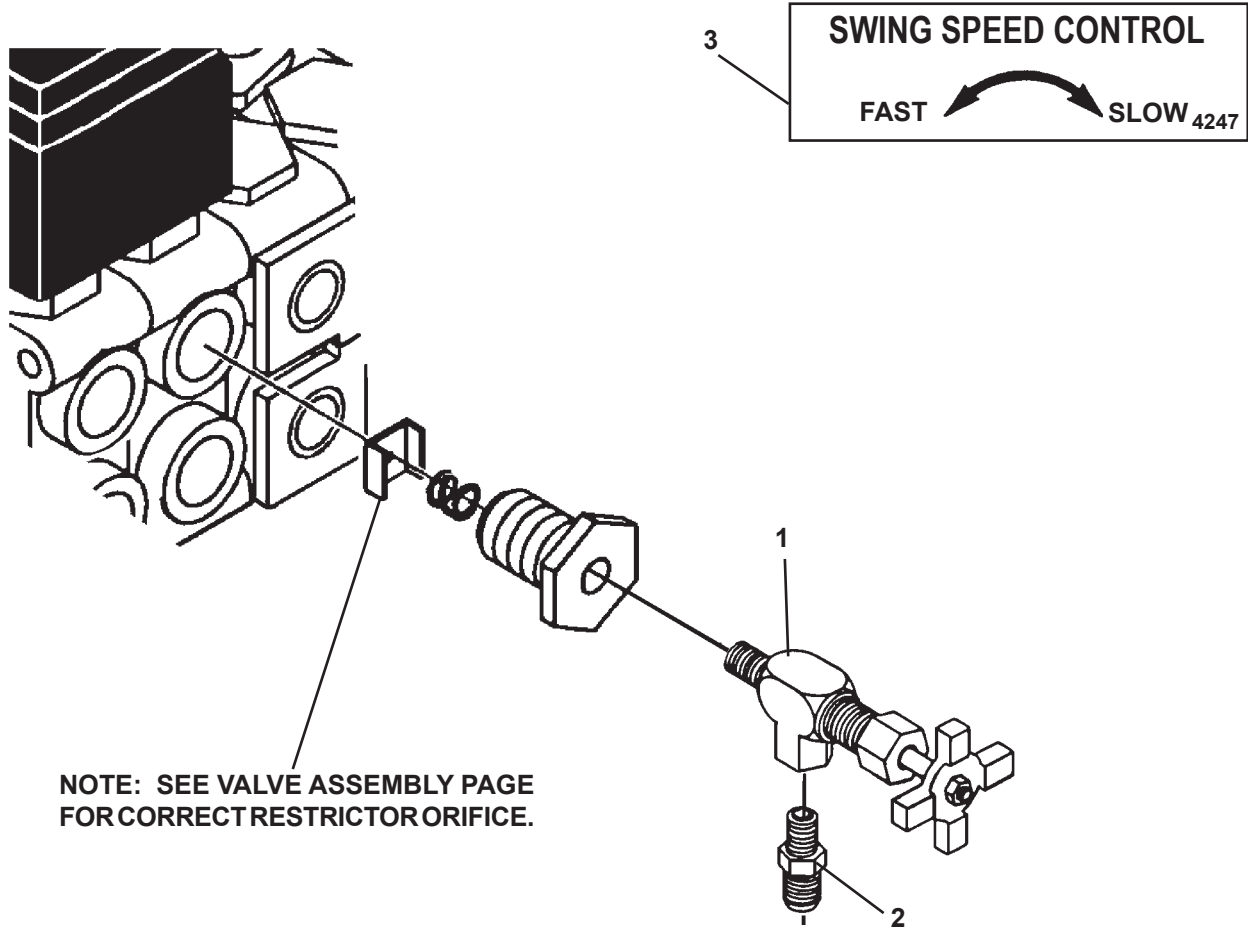

OPTIONAL SWING SPEED CONTROL
ASSEMBLY #83337

<u>NO</u>	<u>REQ'D</u>	<u>PART NO.</u>	<u>DESCRIPTION</u>
1	1	3185	Needle Valve
2	1	3137	Male Connector
3	1	4247	Swing Speed Control Decal

OPTIONAL STEP ASSEMBLY

ASSEMBLY #83650

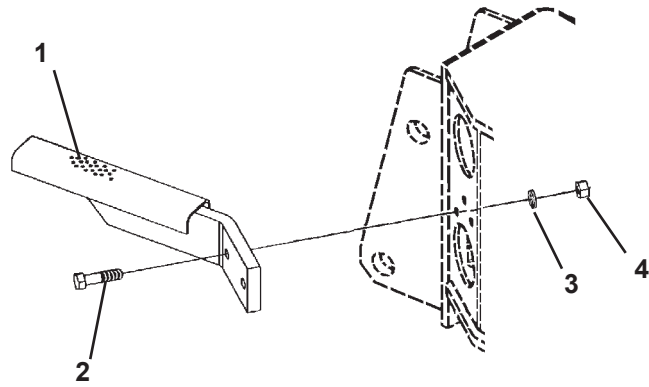

OPTIONAL STEP ASSEMBLY

ASSEMBLY #83650

<u>NO</u>	<u>REQ'D</u>	<u>PART NO.</u>	<u>DESCRIPTION</u>
1	1	83651	Step
2	2	1045	.38" UNC X 1.50" Hex Capscrew
3	2	1503	.38" Lock Washer
4	2	1226	.38" UNC Hex Nut

CYLINDER ASSEMBLY

SWING CYLINDER ASSEMBLY #81022

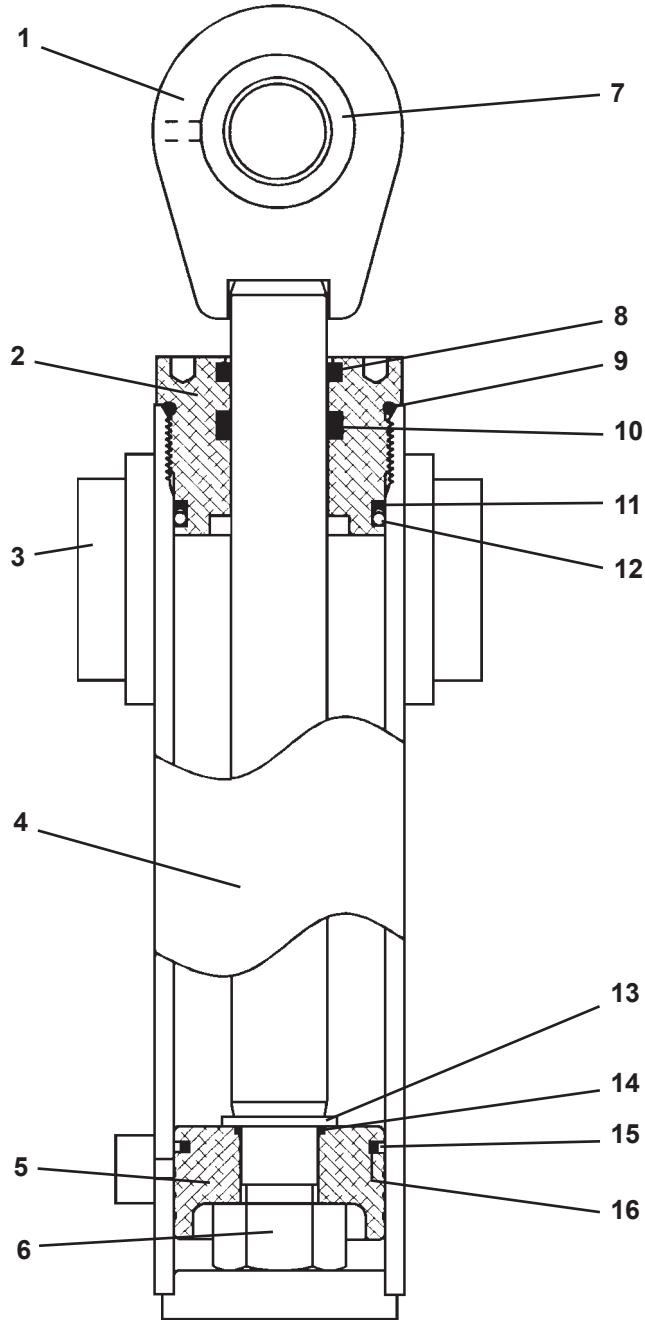

CYLINDER ASSEMBLY
SWING CYLINDER ASSEMBLY #81022

<u>NO</u>	<u>REQ'D</u>	<u>PART NO.</u>	<u>DESCRIPTION</u>
1	1	81024	Cylinder Rod
2	1	77441	Cylinder Gland
3	2	82441	Needle Bearing
4	1	81023	Cylinder Tube
5	1	82578	Piston
6	1	1483	Hex Nut
7	1	62523	Self Aligning Bushing
8	1	45389*	Rod Wiper
9	1	4570*	O'Ring
10	1	45219*	Poly Pak Seal
11	1	45249*	Back-Up Ring
12	1	45557*	O'Ring
13	1	5421	Washer
14	1	4641*	O'Ring
15	1	45251*	Piston Ring
16	1	45250*	O'Ring

NOTE: Seal Kit #45551 Includes all parts marked with an asterisk (*). Parts are not sold separately.

CYLINDER ASSEMBLY

STABILIZER CYLINDER ASSEMBLY #82980

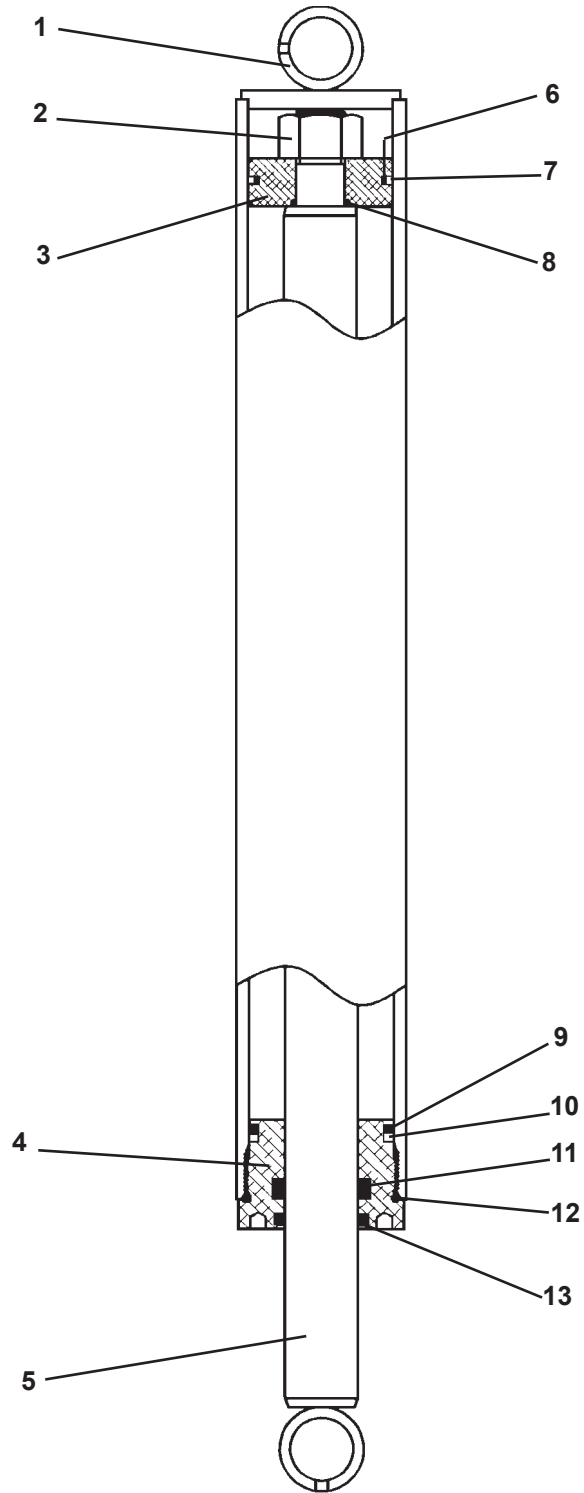

CYLINDER ASSEMBLY
STABILIZER CYLINDER ASSEMBLY #82980

<u>NO</u>	<u>REQ'D</u>	<u>PART NO.</u>	<u>DESCRIPTION</u>
1	1	82981	Cylinder Tube
2	1	1483	Hex Nut
3	1	87170	Piston
4	1	77445	Cylinder Gland
5	1	82986	Cylinder Rod
6	1	45744*	O'Ring
7	1	45743*	Piston Ring
8	1	4641*	O'Ring
9	1	45555*	O'Ring
10	1	4631*	Back-Up Ring
11	1	45225*	Poly Pak Seal
12	1	4908*	O'Ring
13	1	45372*	Rod Wiper

NOTE: Seal Kit #45746 includes all parts marked with an asterisk (*). Parts are not sold separately.

CYLINDER ASSEMBLY

511 & 609 BOOM CYLINDER ASSEMBLY #82625

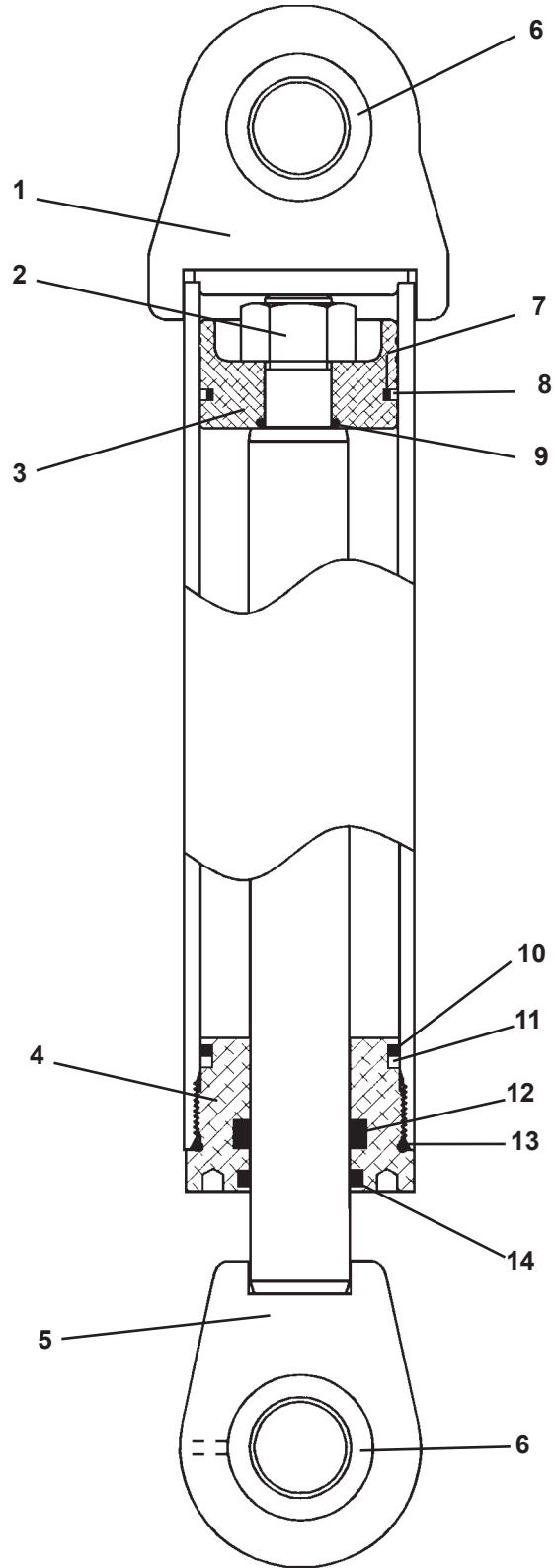

CYLINDER ASSEMBLY

511 & 609 BOOM CYLINDER ASSEMBLY #82625

<u>ITEM</u>	<u>REQ'D</u>	<u>PART NO.</u>	<u>DESCRIPTION</u>
1	1	82635	Cylinder Tube
2	1	1483	Hex Nut
3	1	82793	Piston
4	1	77445	Cylinder Gland
5	1	82636	Cylinder Rod
6	2	6615	Self Aligning Bushing
7	1	4570*	O'Ring
8	1	4569*	Piston Ring
9	1	4641*	O'Ring
10	1	45555*	O'Ring
11	1	4631*	Back-Up Ring
12	1	45225*	Poly Pak Seal
13	1	4908*	O'Ring
14	1	45372*	Rod Wiper

NOTE: Seal Kit #45550 includes all parts marked with an asterisk (*). Parts are not sold separately.

CYLINDER ASSEMBLY

611 BOOM CYLINDER ASSEMBLY #82476

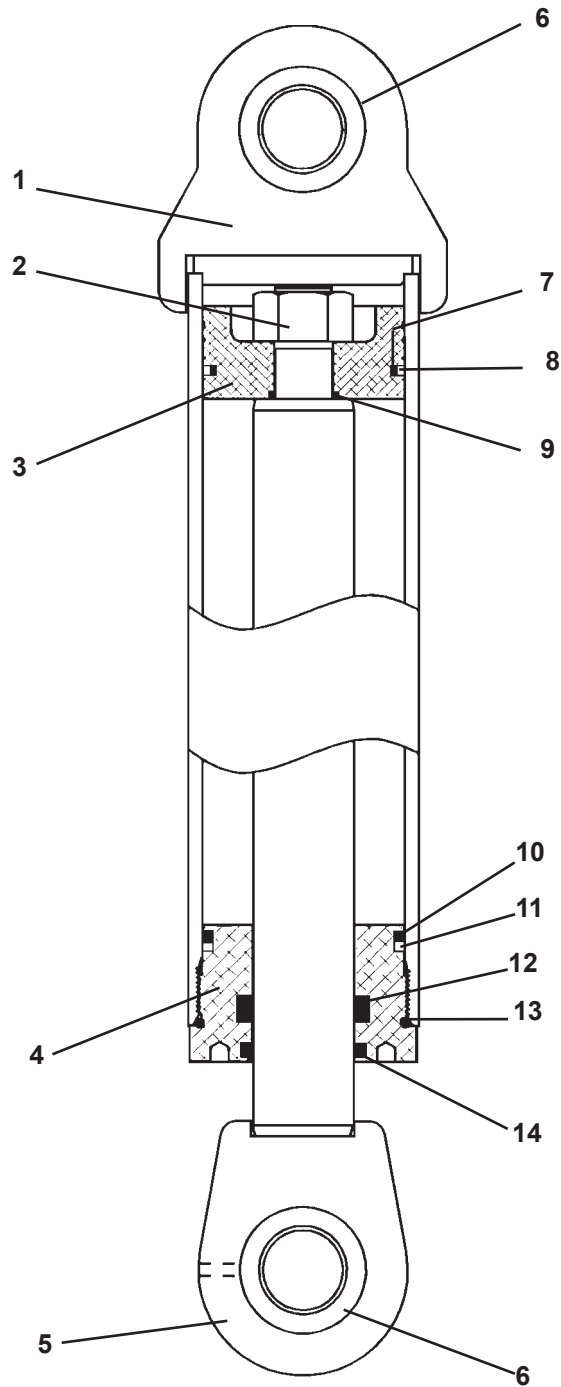

CYLINDER ASSEMBLY
611 BOOM CYLINDER ASSEMBLY #82476

<u>NO</u>	<u>REQ'D</u>	<u>PART NO.</u>	<u>DESCRIPTION</u>
1	1	82481	Cylinder Tube
2	1	1483	Hex Nut
3	1	82817	Piston
4	1	77451	Cylinder Gland
5	1	82482	Cylinder Rod
6	2	6615	Self Aligning Bushing
7	1	45245*	O'Ring
8	1	45244*	Piston Ring
9	1	4641*	O'Ring
10	1	45242*	O'Ring
11	1	45243*	Back-Up Ring
12	1	45119*	Poly Pak Seal
13	1	45412*	O'Ring
14	1	45370*	Rod Wiper

NOTE: Seal Kit #45415 includes all parts marked with an asterisk (*). Parts are not sold separately.

CYLINDER ASSEMBLY

609 DIPPER CYLINDER ASSEMBLY #85782

SERIAL #---8289 AND UP

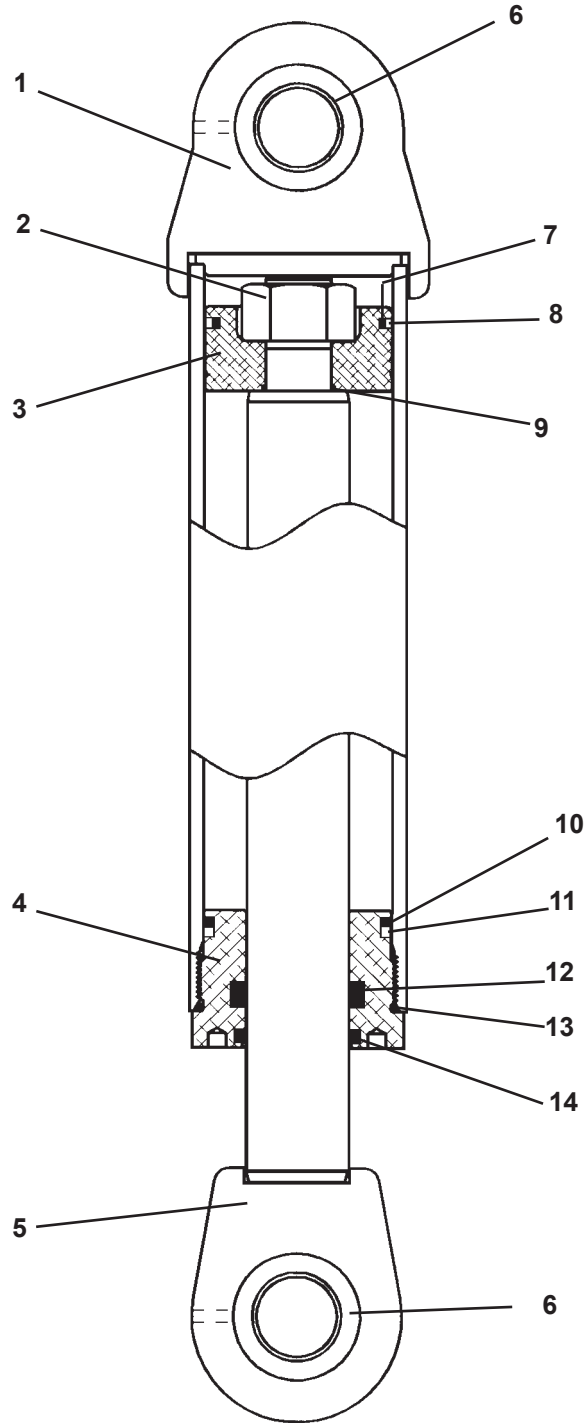

CYLINDER ASSEMBLY

609 DIPPER CYLINDER ASSEMBLY #85782

SERIAL #---8289 AND UP

<u>NO</u>	<u>REQ'D</u>	<u>PART NO.</u>	<u>DESCRIPTION</u>
1	1	85783	Cylinder Tube
2	1	1484	Hex Nut
3	1	85737	Piston
4	1	77447	Cylinder Gland
5	1	82626	Cylinder Rod
6	2	6615	Self Aligning Bushing
7	1	4908*	O'Ring
8	1	4909*	Piston Ring
9	1	4865*	O'Ring
10	1	45559*	O'Ring
11	1	4790*	Back-Up Ring
12	1	45119*	Poly Pak Seal
13	1	45245*	O'Ring
14	1	45370*	Rod Wiper

NOTE: Seal Kit #45375 includes all parts marked with an asterisk (*). Parts are not sold separately.

7516
4-29-04-2

CYLINDER ASSEMBLY

SERVICE PARTS ONLY - 609 DIPPER CYLINDER ASSEMBLY #82624

UP TO SERIAL #---8289

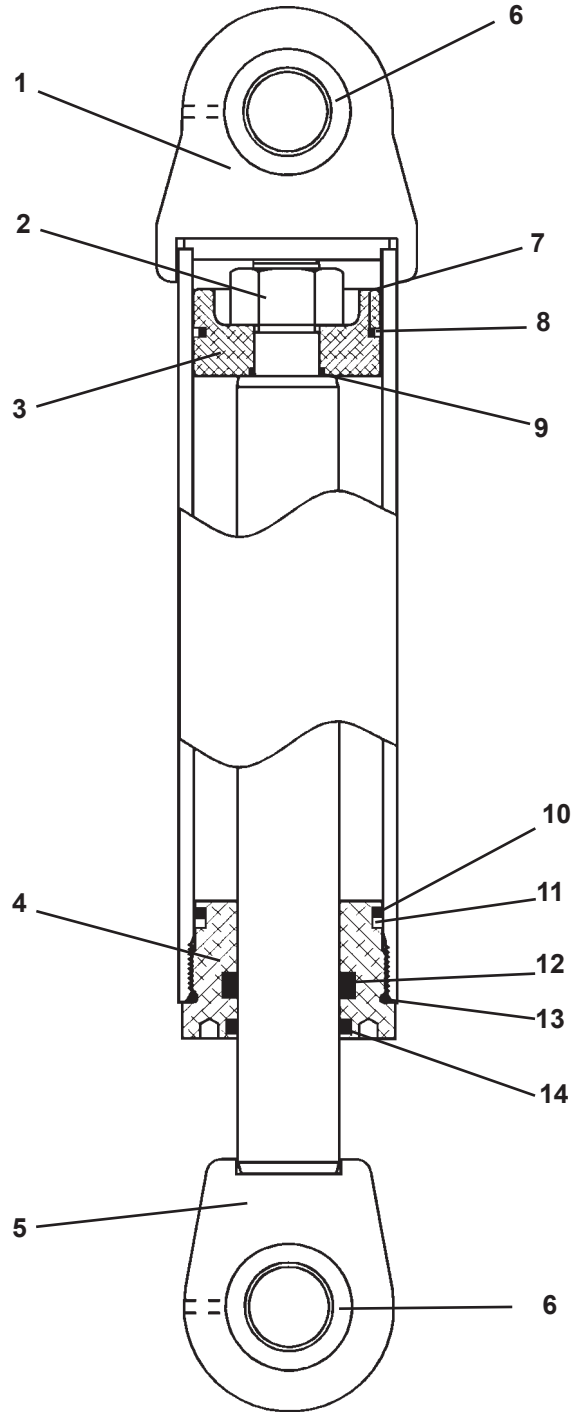

CYLINDER ASSEMBLY

SERVICE PARTS ONLY - 609 DIPPER CYLINDER ASSEMBLY #82624

UP TO SERIAL #---8289

<u>NO</u>	<u>REQ'D</u>	<u>PART NO.</u>	<u>DESCRIPTION</u>
1	1	82628	Cylinder Tube - <i>SEE NOTE</i>
2	1	1484	Hex Nut
3	1	68926	Piston - <i>SEE NOTE</i>
4	1	77447	Cylinder Gland
5	1	82626	Cylinder Rod
6	2	6615	Self Aligning Bushing
7	1	4908*	O'Ring
8	1	4909*	Piston Ring
9	1	4865*	O'Ring
10	1	45559*	O'Ring
11	1	4790*	Back-Up Ring
12	1	45119*	Poly Pak Seal
13	1	45245*	O'Ring
14	1	45370*	Rod Wiper

NOTE: Seal Kit #45375 includes all parts marked with an asterisk (*). Parts are not sold separately.

NOTE: If ordering a complete new dipper cylinder order assembly #85782. The dipper cylinder #82624 (serial #---8288 or before) can be upgraded to the new dipper cylinder #85782 by replacing the cylinder tube and piston (Items #1 & #3) with cylinder tube #82783 and piston #85737.

6854
4-29-04-4

CYLINDER ASSEMBLY

611 DIPPER CYLINDER ASSEMBLY #85779

SERIAL #---8227 AND UP

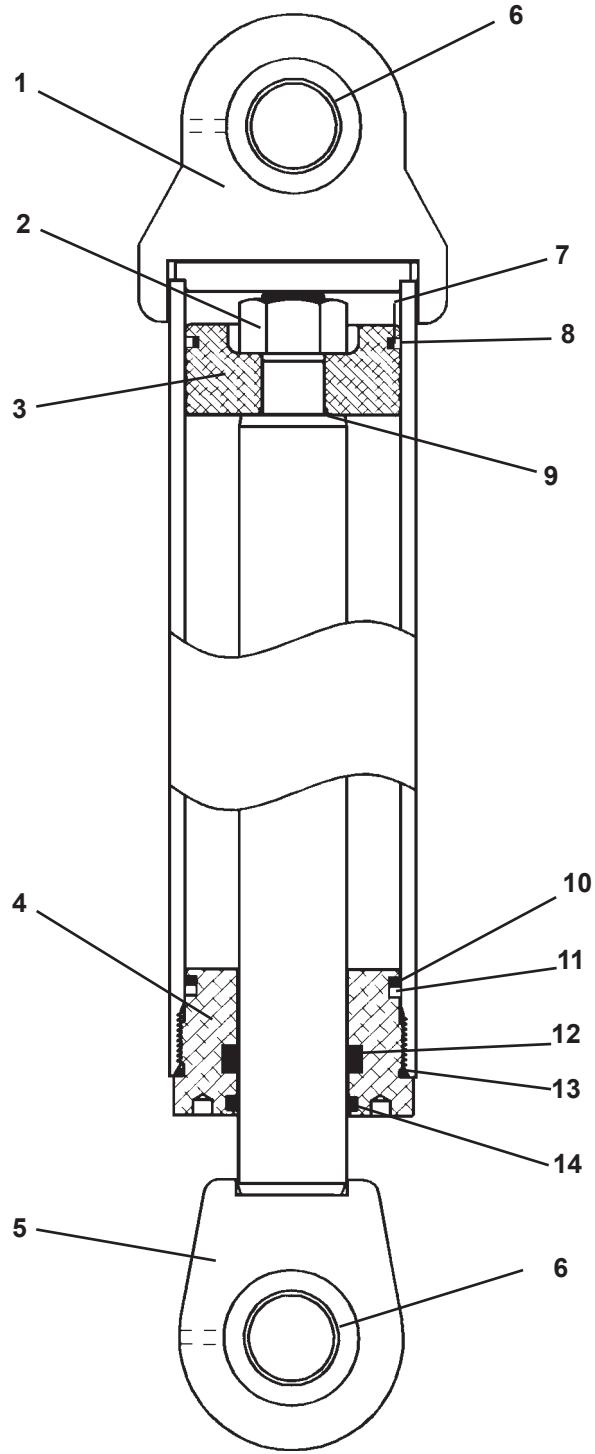

CYLINDER ASSEMBLY

611 DIPPER CYLINDER ASSEMBLY #85779

SERIAL #---8227 AND UP

<u>NO</u>	<u>REQ'D</u>	<u>PART NO.</u>	<u>DESCRIPTION</u>
1	1	85780	Cylinder Tube
2	1	1483	Hex Nut
3	1	85461	Piston
4	1	77451	Cylinder Gland
5	1	82495	Cylinder Rod
6	2	6615	Self Aligning Bushing
7	1	45245*	O'Ring
8	1	45244*	Piston Ring
9	1	4641*	O'Ring
10	1	45242*	O'Ring
11	1	45243*	Back-Up Ring
12	1	45119*	Poly Pak Seal
13	1	45412*	O'Ring
14	1	45370*	Rod Wiper

NOTE: Seal Kit #45415 includes all parts marked with an asterisk (*). Parts are not sold separately.

7518
4-29-04-2

CYLINDER ASSEMBLY

SERVICE PARTS ONLY - 611 DIPPER CYLINDER ASSEMBLY #82478

UP TO SERIAL #---8227

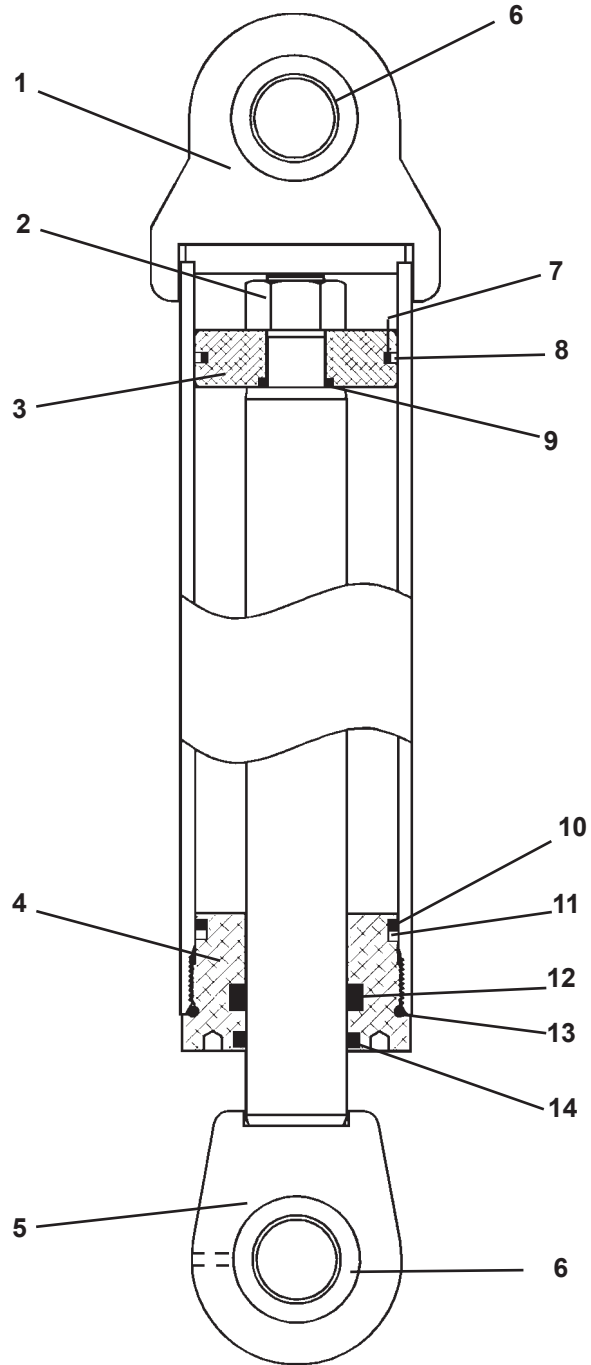

CYLINDER ASSEMBLY

SERVICE PARTS ONLY - 611 DIPPER CYLINDER ASSEMBLY #82478

UP TO SERIAL #---8227

<u>NO</u>	<u>REQ'D</u>	<u>PART NO.</u>	<u>DESCRIPTION</u>
1	1	82494	Cylinder Tube - <i>SEE NOTE</i>
2	1	1483	Hex Nut
3	1	64397	Piston - <i>SEE NOTE</i>
4	1	77451	Cylinder Gland
5	1	82495	Cylinder Rod
6	2	6615	Self Aligning Bushing
7	1	45245*	O'Ring
8	1	45244*	Piston Ring
9	1	4641*	O'Ring
10	1	45242*	O'Ring
11	1	45243*	Back-Up Ring
12	1	45119*	Poly Pak Seal
13	1	45412*	O'Ring
14	1	45370*	Rod Wiper

NOTE: Seal Kit #45415 includes all parts marked with an asterisk (*). Parts are not sold separately.

NOTE: If ordering a complete new dipper cylinder order assembly #85779. The dipper cylinder #82478 (serial #---8226 or before) can be upgraded to the new dipper cylinder #85779 by replacing the cylinder tube and piston (Items #1 & #3) with cylinder tube #85780 and piston #85461.

6875
4-29-04-3

CYLINDER ASSEMBLY

BUCKET CYLINDER ASSEMBLY #117548

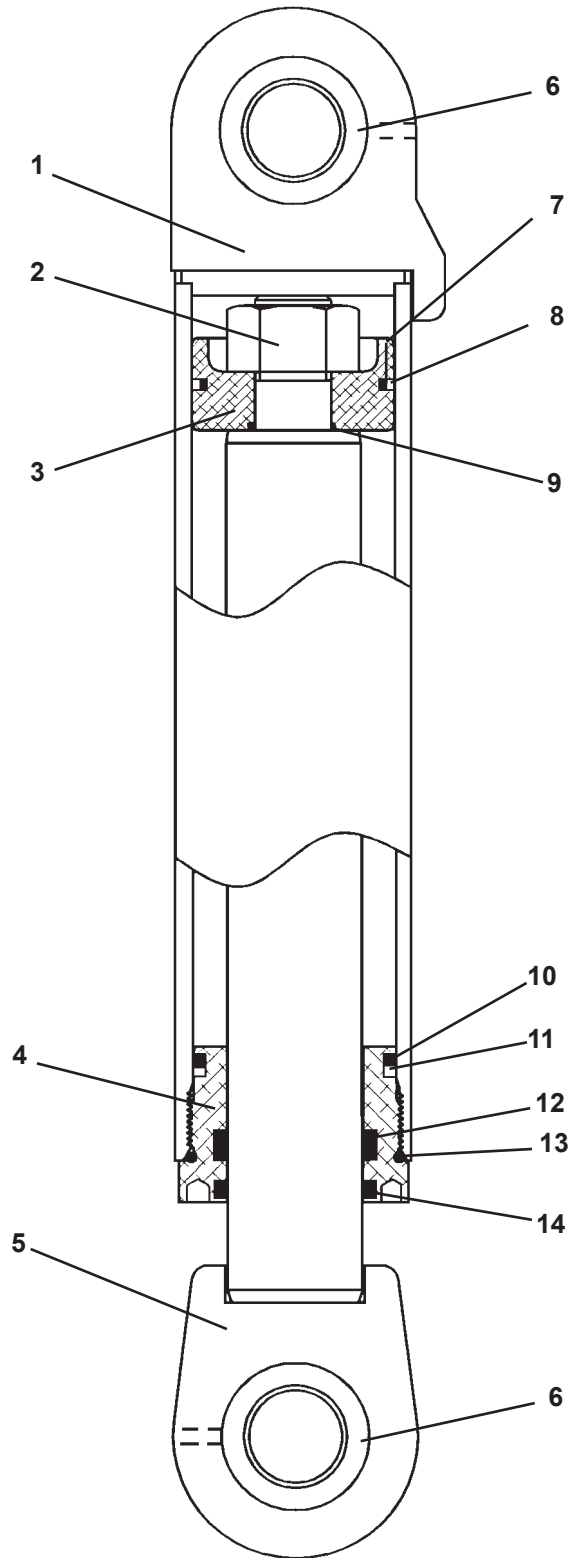

CYLINDER ASSEMBLY
BUCKET CYLINDER ASSEMBLY #117548

<u>ITEM</u>	<u>REQ'D</u>	<u>PART NO.</u>	<u>DESCRIPTION</u>
1	1	117549	Cylinder Tube (See Note)
2	1	1484	Hex Nut
3	1	55904	Piston
4	1	77444	Cylinder Gland
5	1	82506	Cylinder Rod
6	2	6615	Self Aligning Bushing
7	1	4570*	O'Ring
8	1	4569*	Piston Ring
9	1	4865*	O'Ring
10	1	45555*	O'Ring
11	1	4631*	Back-Up Ring
12	1	45117*	Poly Pak Seal
13	1	4908*	O'Ring
14	1	45364*	Rod Wiper

NOTE: Seal Kit #45547 includes all parts marked with an asterisk (*). Parts are not sold separately.

NOTE: The hydraulic ports on the cylinder tube have been relocated towards the center of the cylinder. When replacing the cylinder tube and your existing cylinder hydraulic ports are located at the end of the cylinder tube, two #38766 extension hoses must also be ordered.

MAINFRAME HOSE SET

ASSEMBLY #82761

SN #10067 AND UP

<u>NO</u>	<u>REQ'D</u>	<u>PART NO.</u>	<u>DESCRIPTION</u>
1	4	37553	Hose Assembly .25" X 58" 6FJX-6FJX
2	1	37700	Hose Assembly .25" X 12" 6FJX-6FJX 45° Gooseneck
3	2	37552	Hose Assembly .25" X 14.50" 6FJX-6FJX
4	1	37699	Hose Assembly .25" X 17.00" 6FJX-6FJX

NOTE: Refer to the mainframe assembly for the priority valve hoses which are included in this assembly but have been shown in the mainframe assembly for clarity.

NOTE: Letters on the hose set diagram show the hydraulic hose routing between the backhoe control valve and the various hydraulic cylinders. Simply match the letter on the control valve port to the same letter on the hydraulic hose ends. Example: Hose Assembly labeled "C" runs from the upper Left Stabilizer port on the hydraulic control valve - through the mainframe and to the barrel end fitting on the left stabilizer cylinder.

NOTE: The fittings on the hydraulic cylinders have been altered for clarity purposes. This will assist you in distinguishing between the rod end and the barrel end of the various hydraulic cylinders.

MAINFRAME HOSE SET

ASSEMBLY #82761

UP TO SN #100067

HYDRAULIC CONTROL VALVE

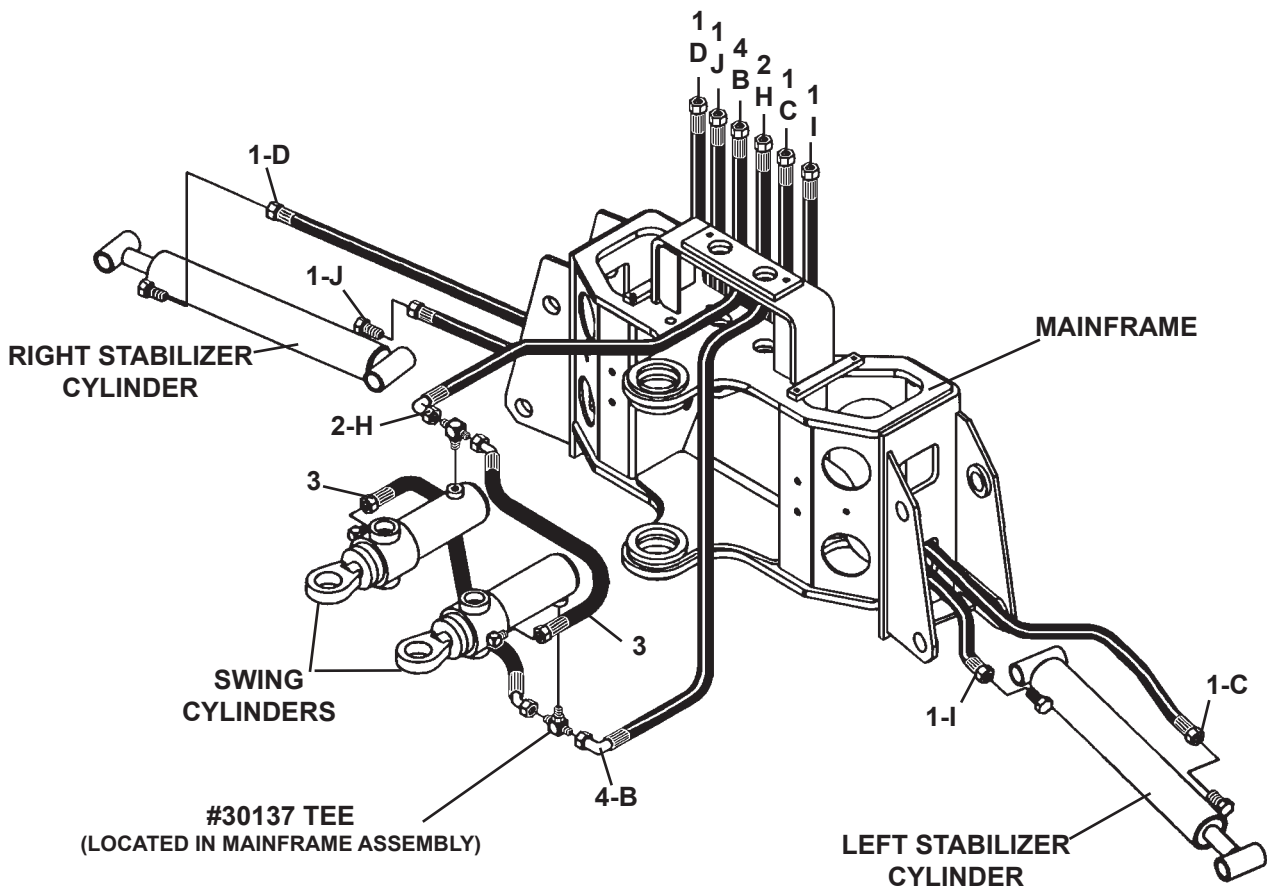
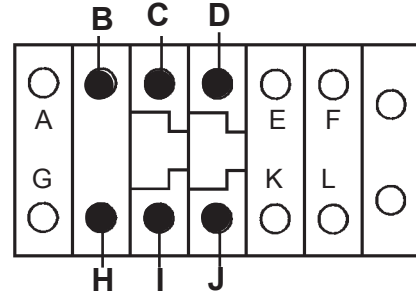

MAINFRAME HOSE SET

ASSEMBLY #82761

UP TO SN #10067

<u>NO</u>	<u>REQ'D</u>	<u>PART NO.</u>	<u>DESCRIPTION</u>
1	4	37553	Hose Assembly .25" X 58" 6FJX-6FJX
2	1	37522	Hose Assembly .25" X 16.35" 6FJX-6FJX 90° Gooseneck
3	2	37552	Hose Assembly .25" X 14.50" 6FJX-6FJX
4	1	37644	Hose Assembly .25" X 17.50" 6FJX-6FJX 90° Short Gooseneck

NOTE: Refer to the mainframe assembly for the priority valve hoses which are included in this assembly but have been shown in the mainframe assembly for clarity.

NOTE: Letters on the hose set diagram show the hydraulic hose routing between the backhoe control valve and the various hydraulic cylinders. Simply match the letter on the control valve port to the same letter on the hydraulic hose ends. Example: Hose Assembly labeled "C" runs from the upper Left Stabilizer port on the hydraulic control valve - through the mainframe and to the barrel end fitting on the left stabilizer cylinder.

NOTE: The fittings on the hydraulic cylinders have been altered for clarity purposes. This will assist you in distinguishing between the rod end and the barrel end of the various hydraulic cylinders.

609 BOOM & DIPPER HOSE SET

ASSEMBLY #82762

HYDRAULIC CONTROL VALVE

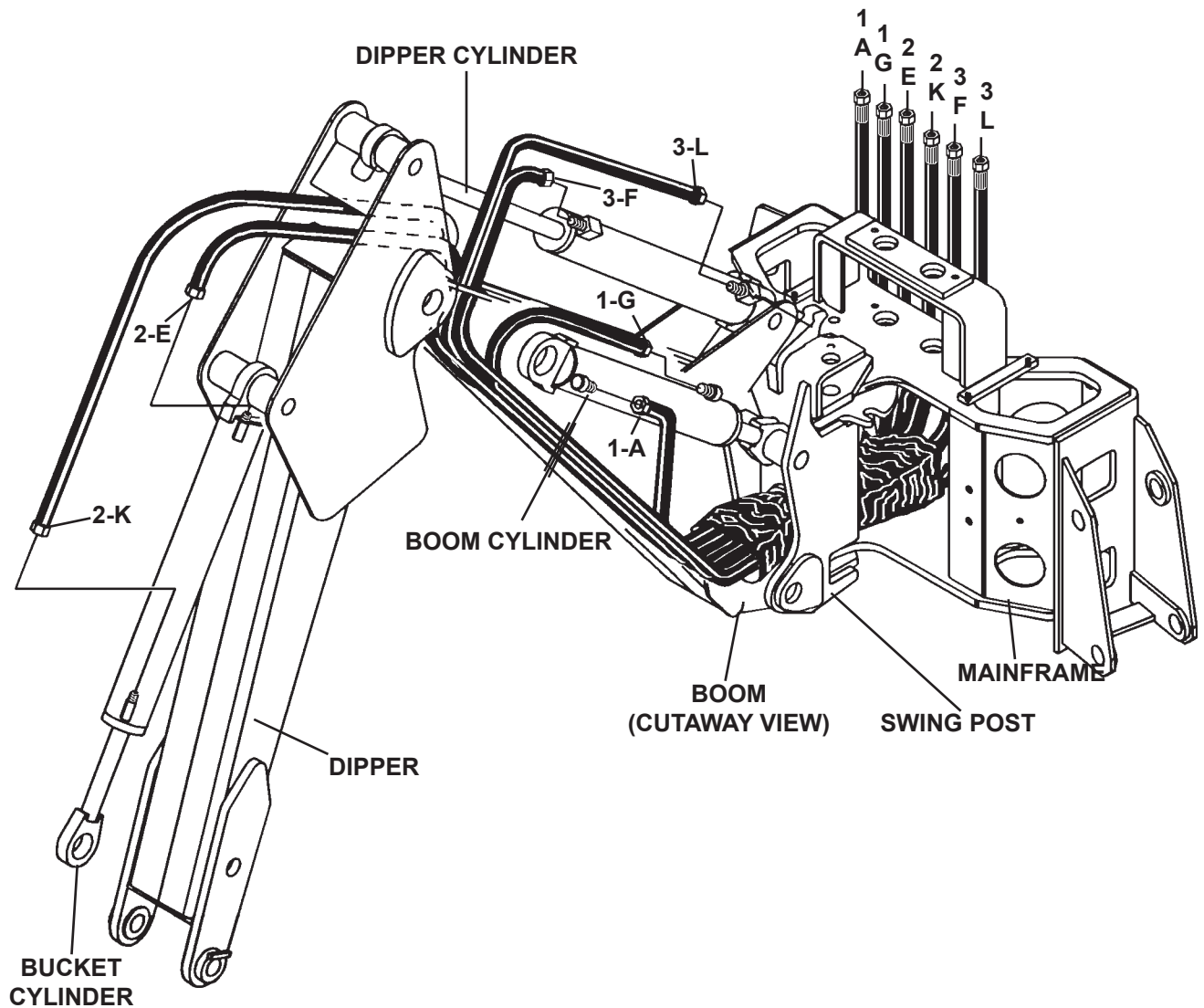
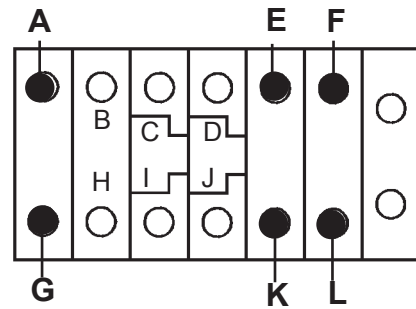

609 BOOM & DIPPER HOSE SET

ASSEMBLY #82762

<u>NO</u>	<u>REQ'D</u>	<u>PART NO.</u>	<u>DESCRIPTION</u>
1	2	37558	Hose Assembly .38" X 93" 8FJX-8FJX
2	2	38760	Hose Assembly .38" X 147" 8FJX-8FJX
3	2	37569	Hose Assembly .38" X 135" 8FJX-8FJX

NOTE: Letters on the hose set diagram show the hydraulic hose routing between the backhoe control valve and the various hydraulic cylinders. Simply match the letter on the control valve port to the same letter on the hydraulic hose ends. Example: Hose Assembly labeled "G" runs from the lower Boom port on the hydraulic control valve - through the mainframe and swing post and to the rod end of the boom cylinder.

NOTE: The fittings on the hydraulic cylinders have been altered for clarity purposes. This will assist you in distinguishing between the rod end and the barrel end of the various hydraulic cylinders.

611 BOOM & DIPPER HOSE SET

ASSEMBLY #82763

HYDRAULIC CONTROL VALVE

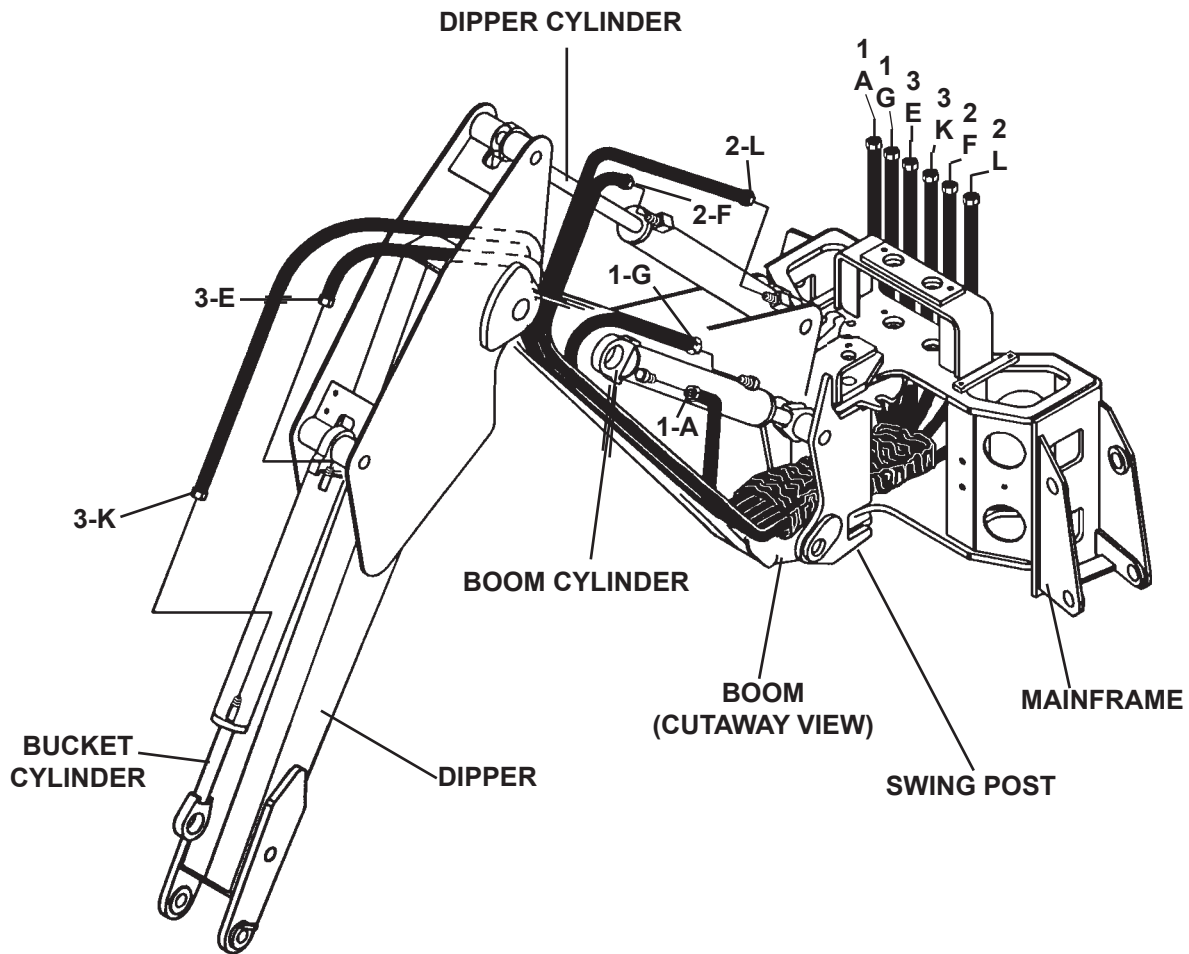
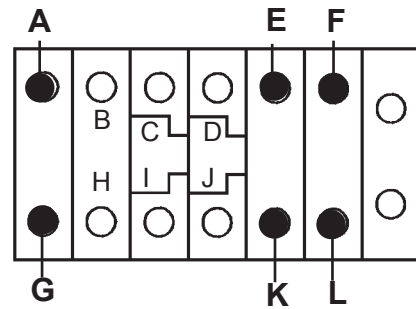

611 BOOM & DIPPER HOSE SET

ASSEMBLY #82763

<u>NO</u>	<u>REQ'D</u>	<u>PART NO.</u>	<u>DESCRIPTION</u>
1	2	37558	Hose Assembly .38" X 93" 8FJX-8FJX
2	2	37559	Hose Assembly .38" X 157" 8FJX-8FJX
3	2	38759	Hose Assembly .38" X 165" 8FJX-8FJX

NOTE: Letters on the hose set diagram show the hydraulic hose routing between the backhoe control valve and the various hydraulic cylinders. Simply match the letter on the control valve port to the same letter on the hydraulic hose ends. Example: Hose Assembly labeled "G" runs from the lower Boom port on the hydraulic control valve - through the mainframe and swing post and to the rod end of the boom cylinder.

NOTE: The fittings on the hydraulic cylinders have been altered for clarity purposes. This will assist you in distinguishing between the rod end and the barrel end of the various hydraulic cylinders.

STABILIZER PADS

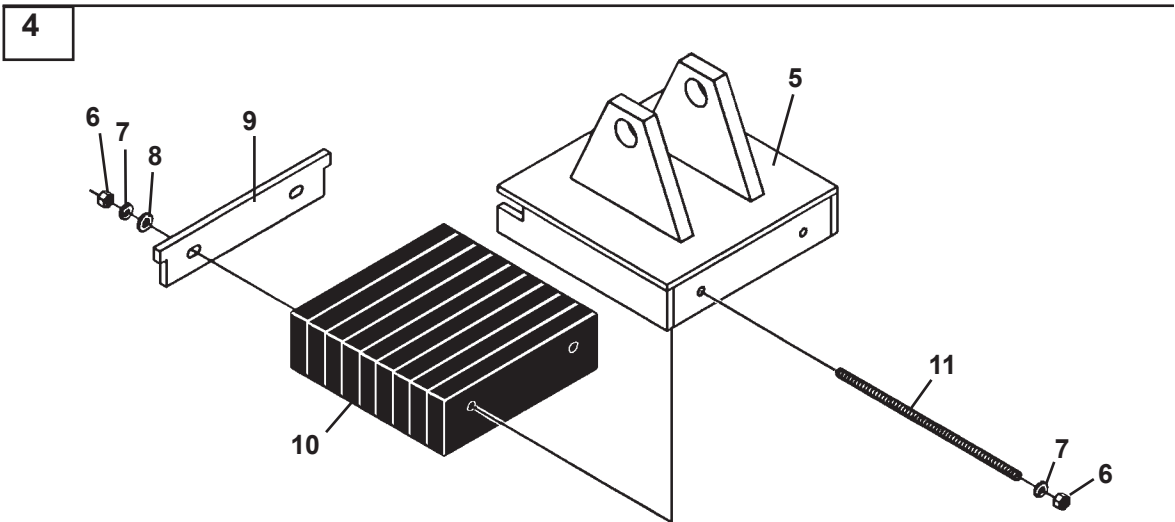
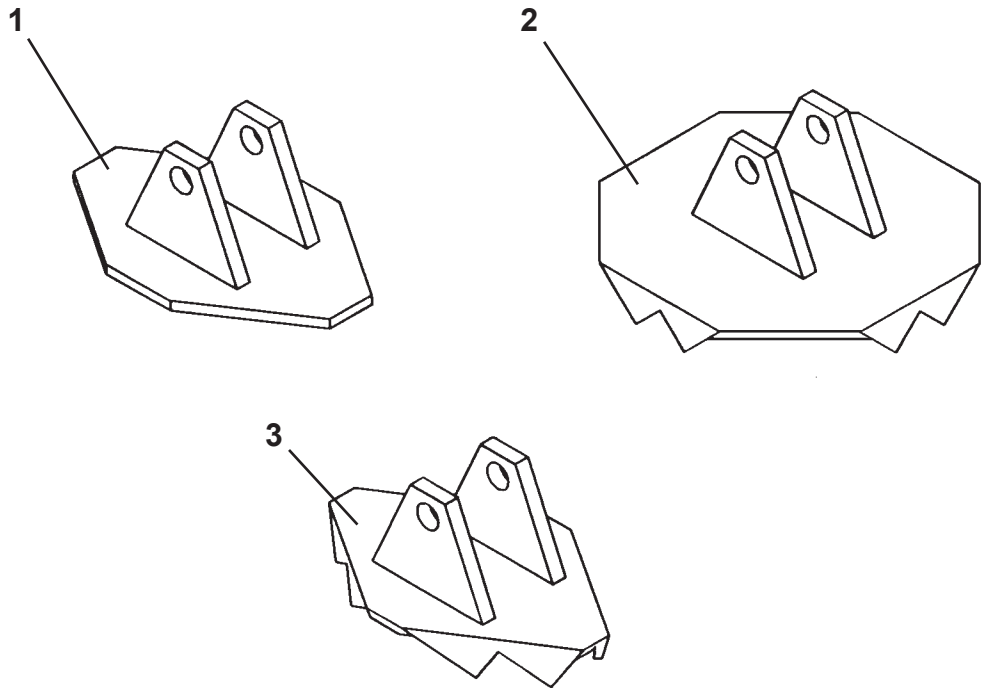

STABILIZER PADS

FLAT STABILIZER PAD ASSEMBLY - #83055

<u>NO</u>	<u>REQ'D</u>	<u>PART NO.</u>	<u>DESCRIPTION</u>
1	2	83079	Flat Stabilizer Pad

LARGE GROUSER PAD ASSEMBLY - #83057

<u>NO</u>	<u>REQ'D</u>	<u>PART NO.</u>	<u>DESCRIPTION</u>
2	2	83086	Large Grouser Pad

GROUSER PAD ASSEMBLY - #83054

<u>NO</u>	<u>REQ'D</u>	<u>PART NO.</u>	<u>DESCRIPTION</u>
3	2	83059	Grouser Stabilizer Pad

RUBBER STABILIZER PAD ASSEMBLY - #83056

<u>NO</u>	<u>REQ'D</u>	<u>PART NO.</u>	<u>DESCRIPTION</u>
4	2	83084	Rubber Stabilizer Pad Assembly (Includes Items 5 through 11)
5	1	83085	Stabilizer Pad
6	4	1226	.38" UNC Hex Nut
7	4	1503	.38" Lock Washer
8	2	1514	.38" Flat Washer
9	1	51190	Slide Plate
10	1	64412	Rubber Strip Bundle
11	2	1661	.38" UNC X 11.50" Readi Bolt

STABILIZER PADS

FLIP-OVER STABILIZER PAD ASSEMBLY #83091
(COMPLETE SET OF (2) FLIP-OVER PADS - ASSEMBLY #83058)

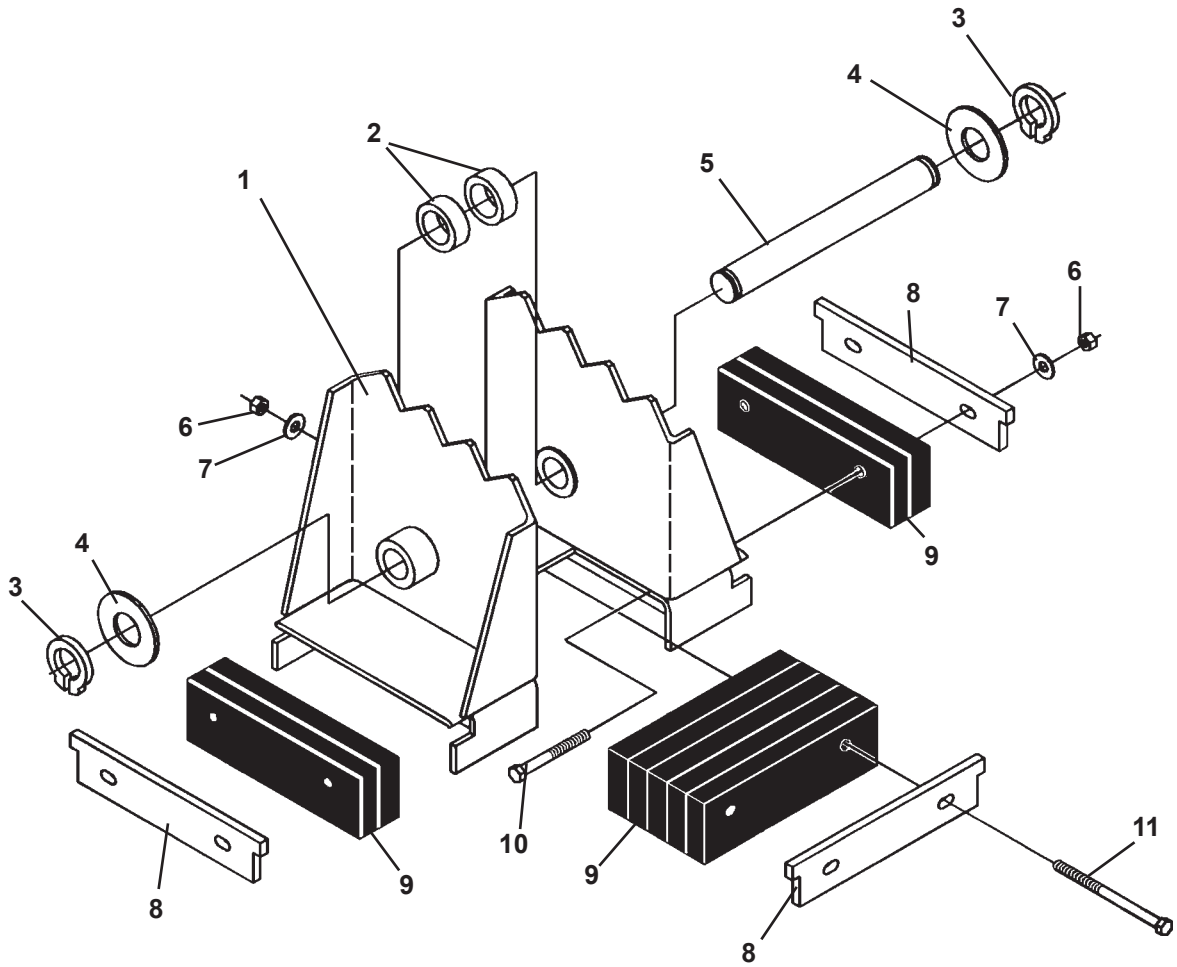

STABILIZER PADS

FLIP-OVER STABILIZER PAD ASSEMBLY #83091
(COMPLETE SET OF (2) FLIP-OVER PADS - ASSEMBLY #83058)

<u>ITEM</u>	<u>REQ'D</u>	<u>PART NO.</u>	<u>DESCRIPTION</u>
1	1	84496	Flip-Over Pad
2	2	84495	Spacer
3	2	1652	1.25" Snap Ring
4	VARIABLES	57693	Thrust Washer 1.25" X .078"
	VARIABLES	64727	Thrust Washer 1.25" X .125"
5	1	83096	Pin
6	6	1837	.38" UNC Hex Deformed Lock Nut
7	6	1514	.38" Flat Washer
8	3	51190	Slide Plate
9	1	64412	Rubber Strip Bundle
10	4	1053	.38" UNC X 3.50" Hex Capscrew
11	2	1057	.38" UNC X 5.00" Hex Capscrew

OPTIONAL STABILIZER CYLINDER COVER

STABILIZER CYLINDER COVER ASSEMBLY #83851

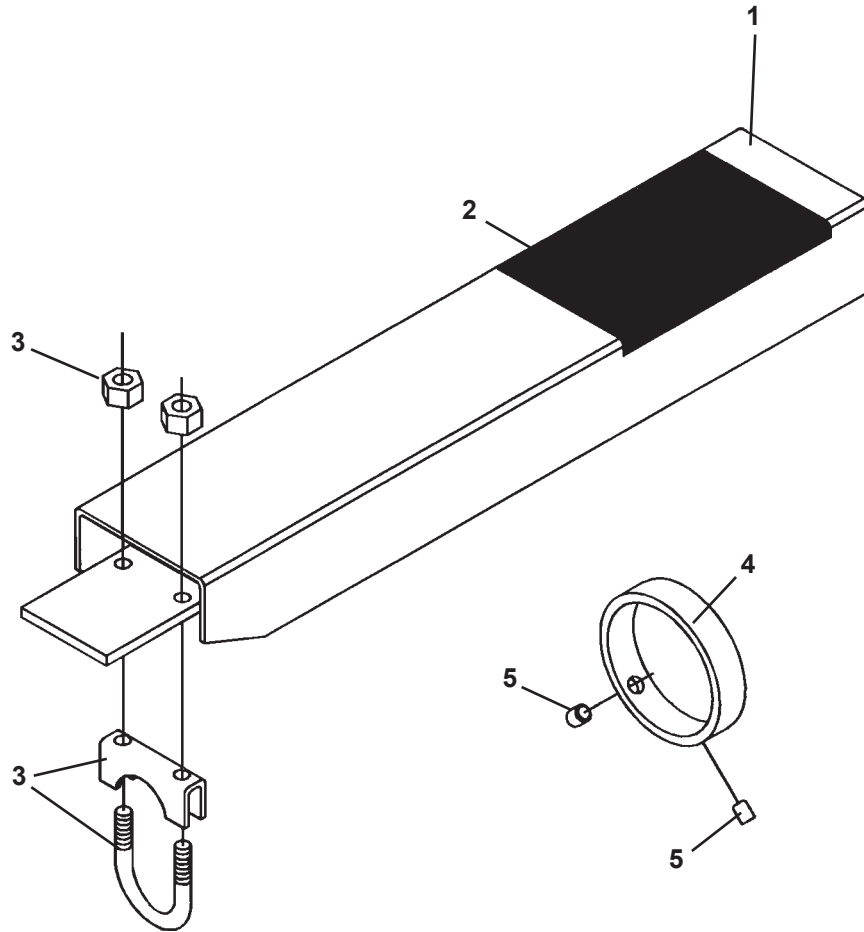

OPTIONAL STABILIZER CYLINDER COVER

STABILIZER CYLINDER COVER ASSEMBLY #83851

<u>NO</u>	<u>REQ'D</u>	<u>PART NO.</u>	<u>DESCRIPTION</u>
1	2	83852	Stabilizer Cylinder Cover with Decal
2	2	4167	No Step Decal
3	2	83906	Muffler Clamp Assembly
4	2	83856	Guide Ring
5	4	1575	.38" UNC X .50" Set Screw

BUCKET ASSEMBLIES

POWER DIG BUCKETS

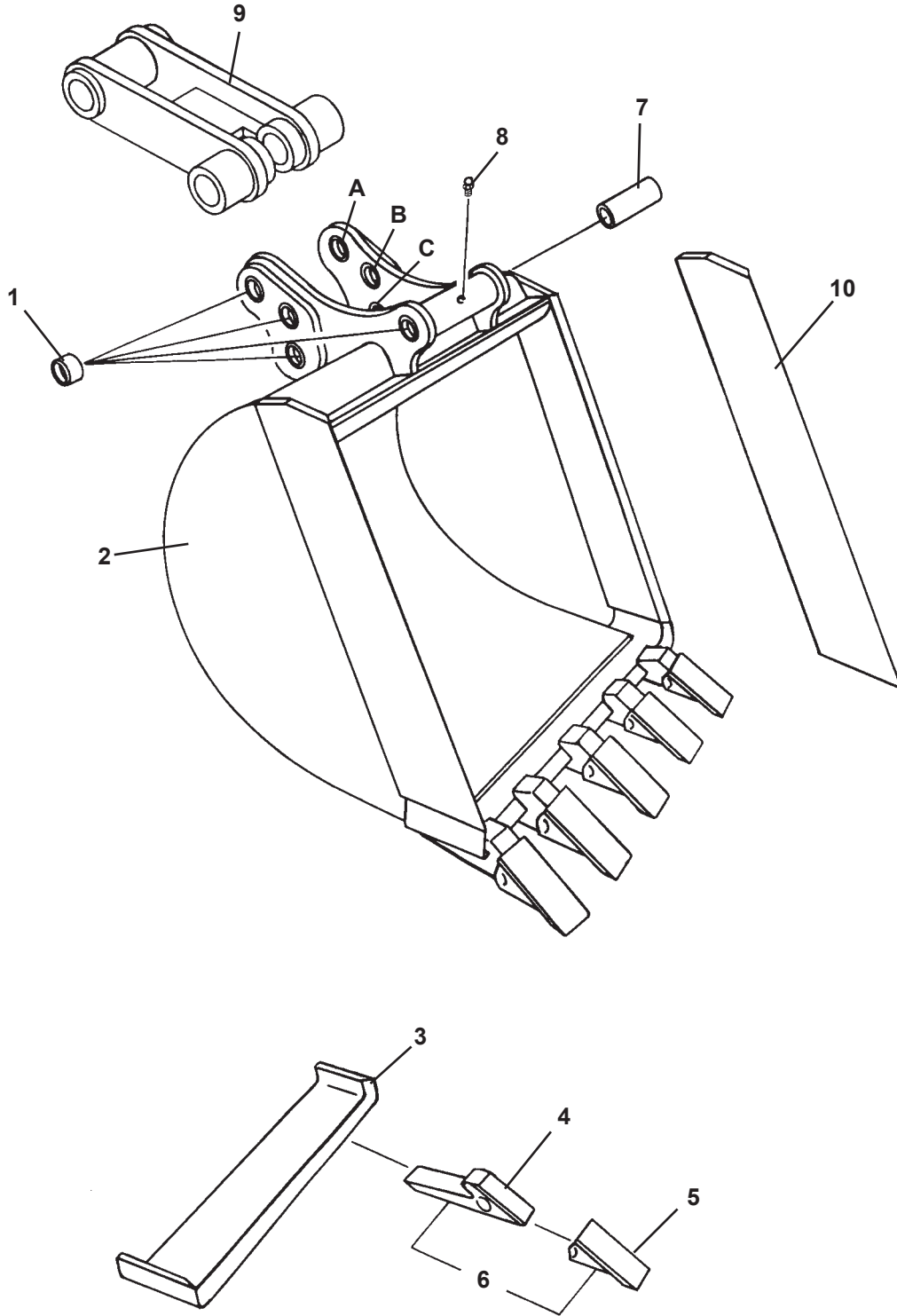

BUCKET ASSEMBLIES

POWER DIG BUCKETS

<u>NO</u>	<u>REQ'D</u>	<u>PART NO.</u>	<u>DESCRIPTION</u>
1	8	6355	Bushing
2	1	67412	12" Bucket Weldment
		67416	16" Bucket Weldment
		67418	18" Bucket Weldment
		67420	20" Bucket Weldment
		67424	24" Bucket Weldment
3	1	67399	12" Replacement Front Cutter Edge
		67393	16" Replacement Front Cutter Edge
		67387	18" Replacement Front Cutter Edge
		67338	20" Replacement Front Cutter Edge
		66387	24" Replacement Front Cutter Edge
4	Varies	55090	Replacement Tooth Shank
5	Varies	55088	Replacement Tooth Point
6	Varies	56073	Replacement Tooth Point and Shank Assembly
7	1	68482	Spacer
8	1	6616	Grease Zerk
9	Optional	82948	Bell Hole Bucket Link (Requires 3 Grease Zerks - Part #6616)
10	1	67151	Left Replacement Side Cutter
	1	67152	Right Replacement Side Cutter

NOTE:

Power dig buckets have three different bucket link positions for different digging needs.

Position "A" power digging position for added digging force in hard ground.

Position "B" truck loading position for greater ease of spoil removal and higher dump height.

Position "C" standard digging position with a good balance of digging force and bucket rotation for general digging use.

BUCKET ASSEMBLIES

SEVERE DUTY BUCKETS

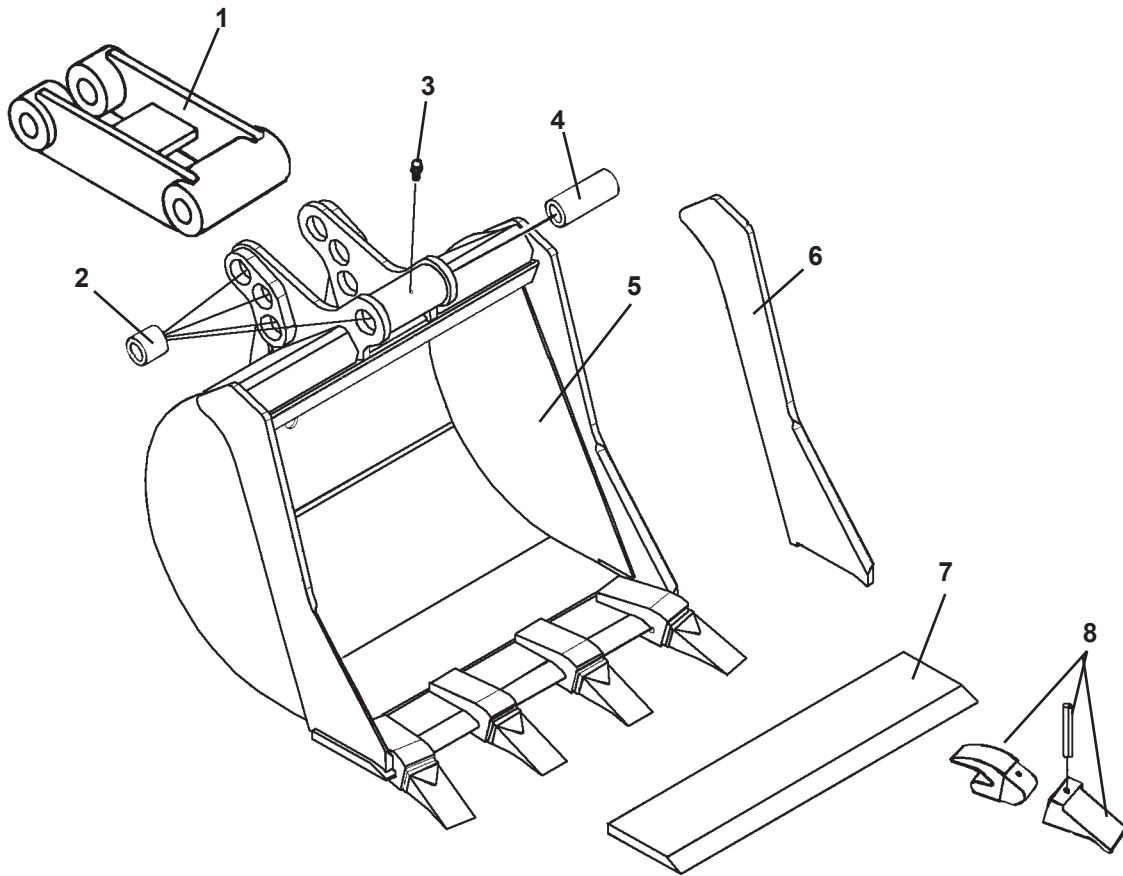

OLD STYLE BUCKET

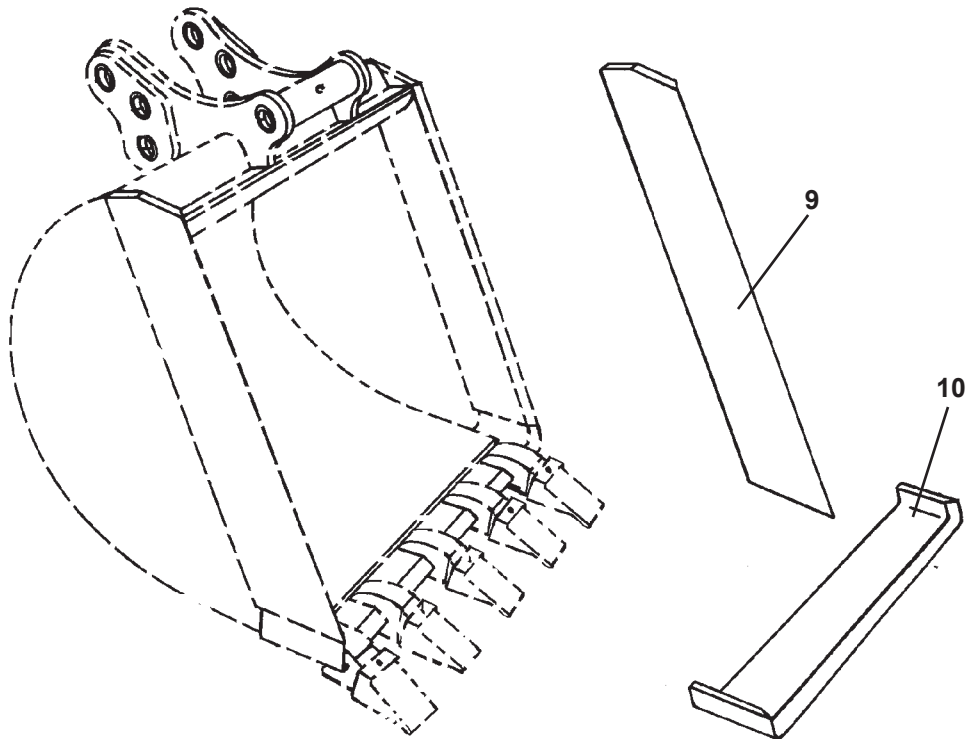

BUCKET ASSEMBLIES

SEVERE DUTY BUCKETS

NOTE: ALL SEVERE DUTY BUCKETS HAVE BEEN REPLACED WITH A NEW BUCKET WELDMENT WHICH INCLUDES A STRAIGHT FRONT CUTTING EDGE AND MORE AGGRESSIVE SIDE CUTTERS. WHEN ORDERING REPLACEMENT CUTTING EDGES FOR THE OLDER STYLE BUCKETS PLEASE REFER TO ITEMS #9 AND #10.

<u>ITEM</u>	<u>REQ'D</u>	<u>PART NO.</u>	<u>DESCRIPTION</u>
1	Optional	82948	Bell Hole Bucket Link (Requires 3 Grease Zerks #6616)
2	8	6355	Bushing (500 & 600 Series Backhoes)
3	1	6616	Grease Zerk
4	1	68482	Spacer
5	1	103312	12" Bucket Weldment
		103316	16" Bucket Weldment
		103318	18" Bucket Weldment
		103320	20" Bucket Weldment
		103324	24" Bucket Weldment
6	1	102875	Left Replacement Side Cutter
	1	102874	Right Replacement Side Cutter
7	1	102866	12" Replacement Front Cutter Edge
		102867	16" Replacement Front Cutter Edge
		102868	18" Replacement Front Cutter Edge
		102869	20" Replacement Front Cutter Edge
		102870	24" Replacement Front Cutter Edge
8	Varies	85003	Replacement Tooth Point and Shank Assembly
		74228	Replacement Tooth Shank (Weld On)
		84863	Replacement Tooth (Bolt On)
		74227	Spiral Roll Pin

OLD STYLE SEVERE DUTY BUCKETS

9	1	67151	Left Replacement Side Cutter
	1	67152	Right Replacement Side Cutter
10	1	85236	12" Replacement Front Cutter Edge
		85241	16" Replacement Front Cutter Edge
		85246	18" Replacement Front Cutter Edge
		85251	20" Replacement Front Cutter Edge
		85256	24" Replacement Front Cutter Edge

NOTE:

Severe duty buckets have three different bucket link positions for different digging needs.

Position "A" digging position for added digging force in hard ground.

Position "B" truck loading position for greater ease of spoil removal and higher dump height.

Position "C" standard digging position with a good balance of digging force and bucket rotation for general digging use.

FIRST LINE REPAIR KIT

ASSEMBLY #83758

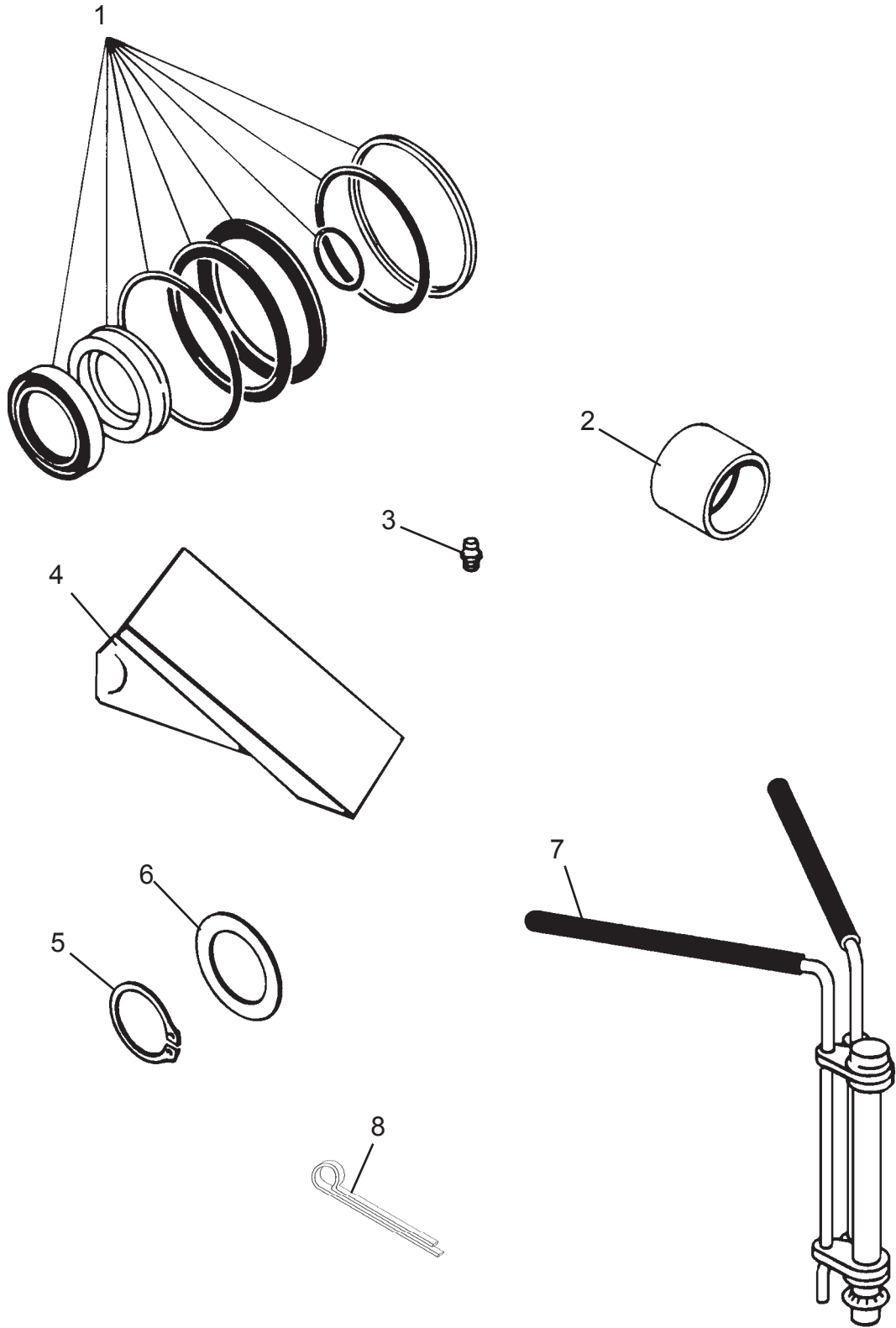

FIRST LINE REPAIR KIT

ASSEMBLY #83758

<u>NO</u>	<u>REQ'D</u>	<u>PART NO.</u>	<u>DESCRIPTION</u>
1	1	45375	Seal Kit (Dipper Cylinder)
	1	45547	Seal Kit (Bucket Cylinder)
	2	45550	Seal Kit (Boom/Stabilizer Cylinders)
	1	45551	Seal Kit (Swing Cylinder)
2	2	81610	Bushing
	2	6355	Bushing
3	4	6616	Grease Zerk
4	4	84863	Severe Duty Bucket Tooth
5	4	1650	Snap Ring 1.38"
6	4	6623	Thrust Washer 1.38" X .031"
7	1	65349	Cylinder Seal Install Tool
8	2	1613	Cotter Pin

FIRST LINE REPAIR KIT

ASSEMBLY #83759

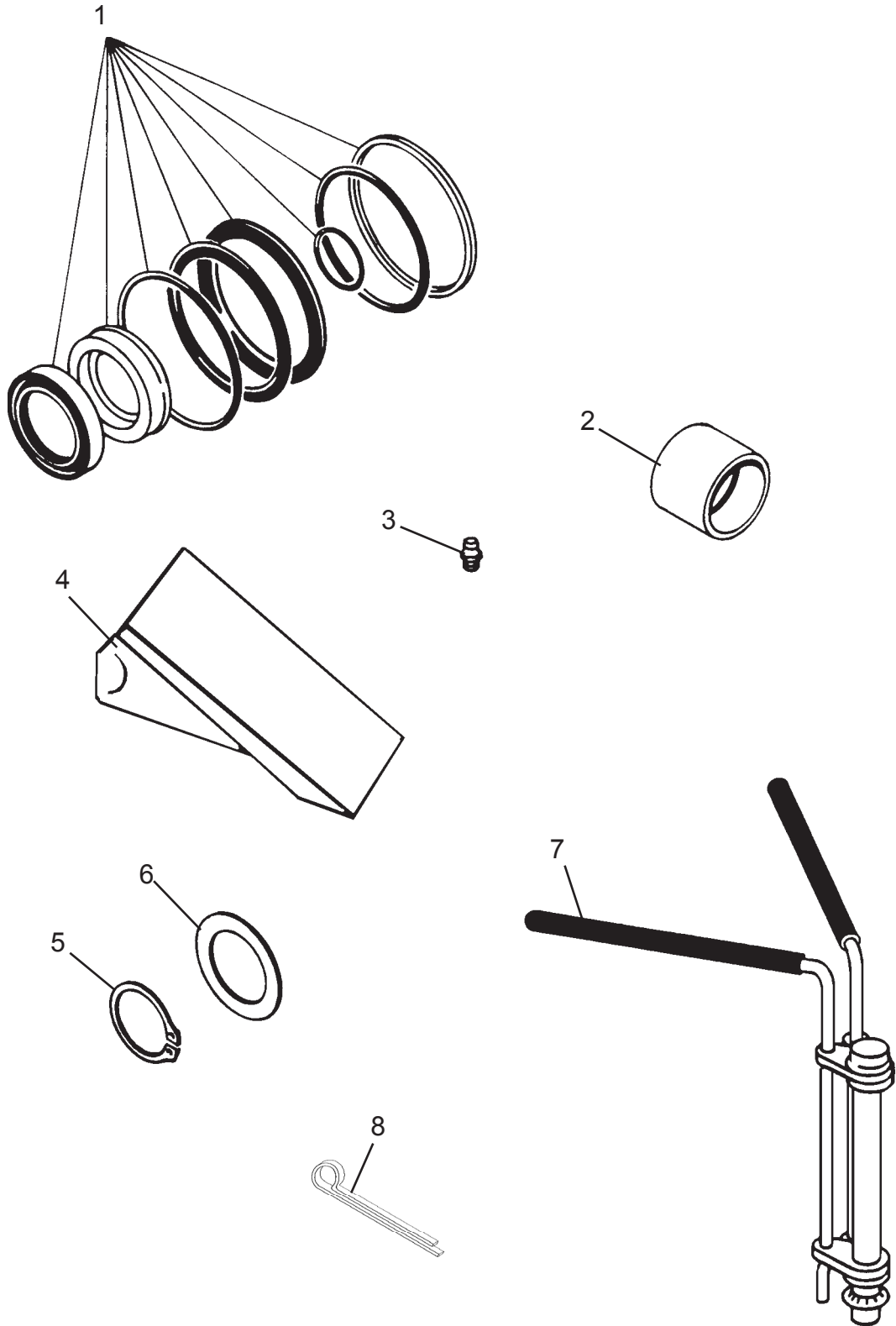

FIRST LINE REPAIR KIT

ASSEMBLY #83759

<u>NO</u>	<u>REQ'D</u>	<u>PART NO.</u>	<u>DESCRIPTION</u>
1	2	45415	Seal Kit (Boom/Dipper Cylinder)
	1	45547	Seal Kit (Bucket Cylinder)
	1	45550	Seal Kit (Stabilizer Cylinders)
	1	45551	Seal Kit (Swing Cylinder)
2	2	81610	Bushing
	2	6355	Bushing
3	4	6616	Grease Zerk
4	4	84863	Severe Duty Bucket Tooth
5	4	1650	Snap Ring 1.38"
6	4	6623	Thrust Washer 1.38" X .031"
7	1	65349	Cylinder Seal Install Tool
8	2	1613	Cotter Pin

DECALS

DECAL PLACEMENT

GENERAL INFORMATION

The diagrams on this page shows the location of all the decals used on the 609 and 611 backhoes. The decals are identified by their part numbers, with reductions of the actual decals located on the following pages. Use this information to order replacements for lost or damaged decals. Be sure to read all decals before operating the backhoe. They contain information you need to know for both safety and backhoe longevity.

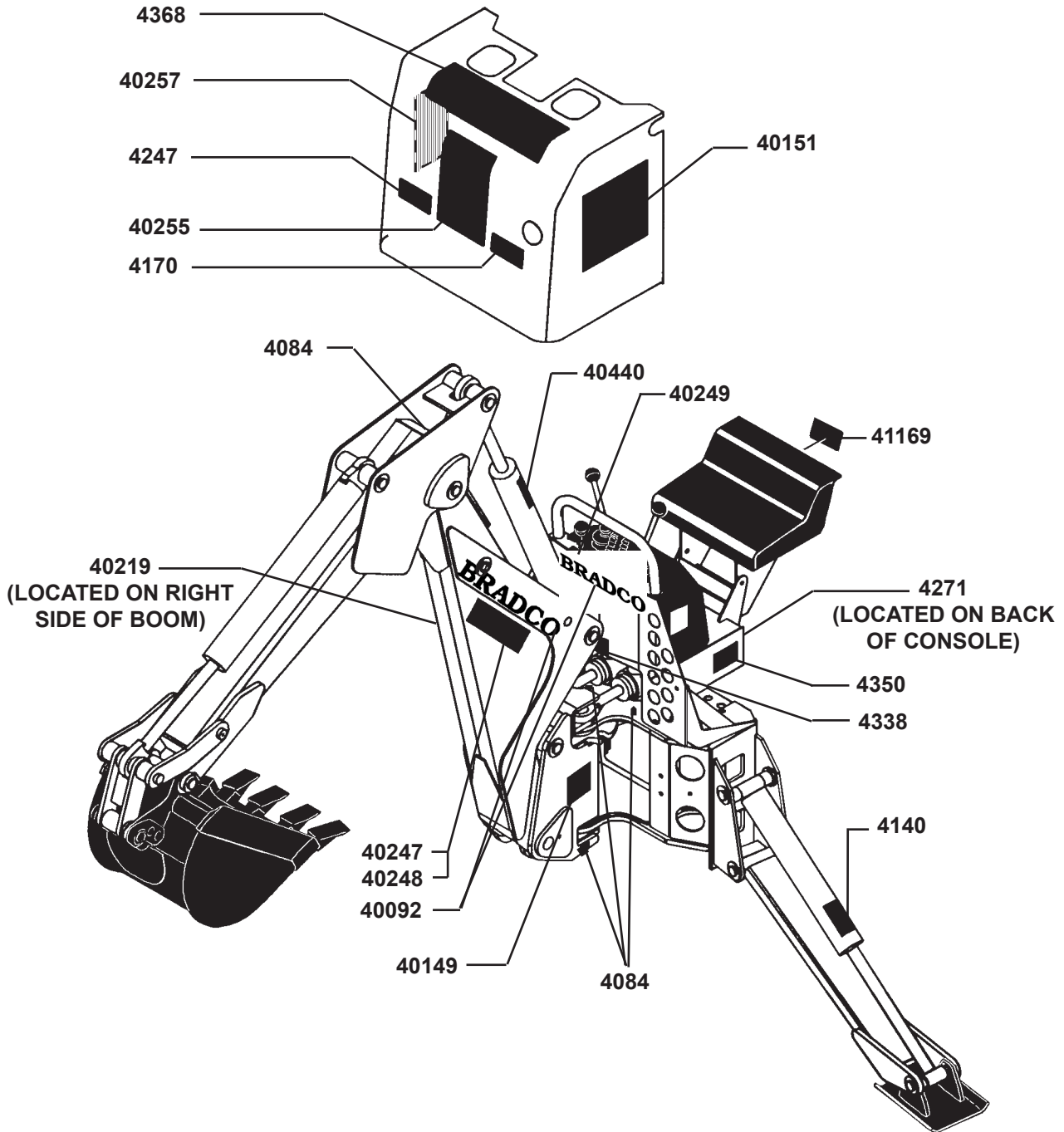

DECALS

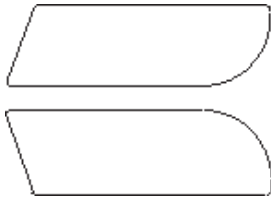

BRADCO

**PART #40092 (3 REQ'D)
BRADCO LOGO**

609

**PART #40247 (2 REQ'D)
609 MODEL NUMBER**

611

**PART #40248 (2 REQ'D)
611 MODEL NUMBER**

SERVICE INFORMATION #4271

THIS IS AN INLINE 90 MICRON SINTERED BRONZE FILTER. IF PLUGGED OR PARTIALLY FILLED IT WILL REDUCE BACKHOE PERFORMANCE. REMOVE AND WASH OUT REGULARLY. REPLACE ELEMENT #45133 IF DIFFICULT TO BLOW THROUGH AFTER WASHING. SEE FULL INSTRUCTIONS IN OWNERS MANUAL.

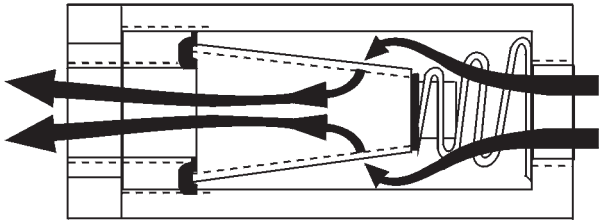

**PART #4271
INLINE FILTER DECAL**

6858
10-19-12-3

DECALS



PART #40151
HIGH PRESSURE FLUID DECAL



PART #41169
DANGER! BACKHOE SECURE

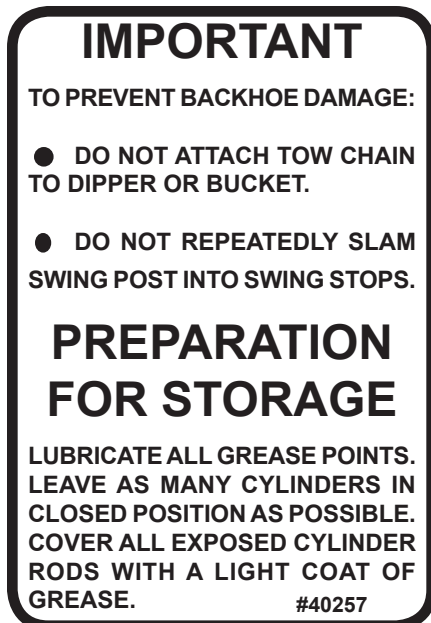

PART #40257
IMPORTANT! DECAL

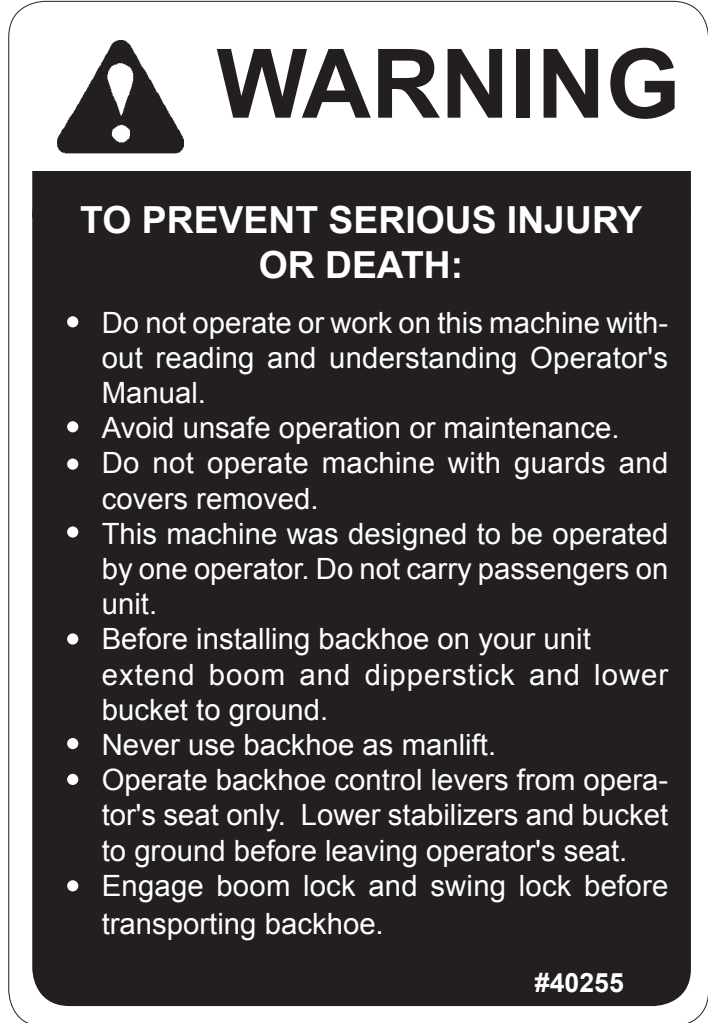

PART #40255
OPERATIONAL WARNING DECAL



PART #40149
DANGER! PINCH POINTS

DECALS

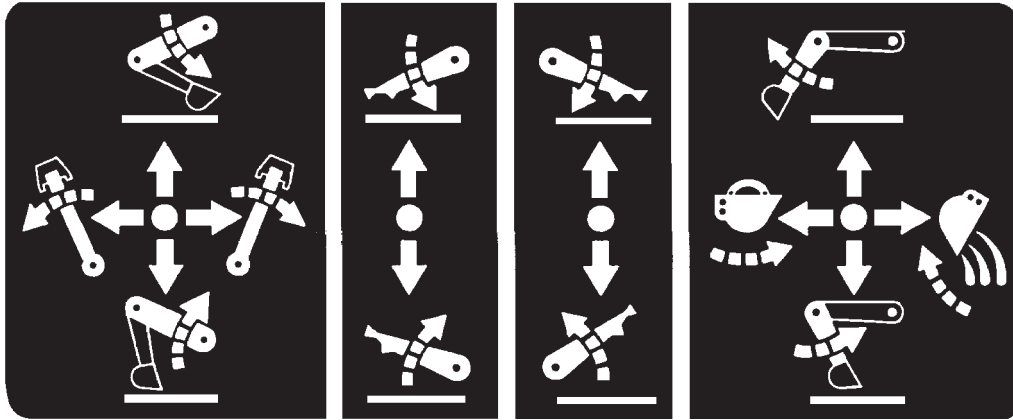

**PART #4368
OPERATING CONTROLS DECAL**

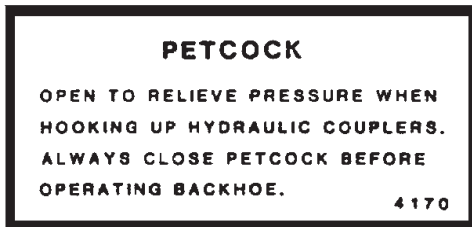

**PART #4170
PETCOCK OPERATION DECAL**

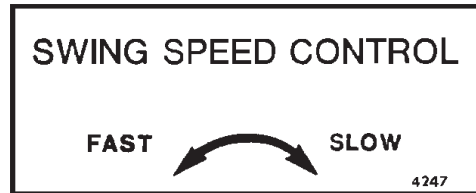

**PART #4247
SWING SPEED CONTROL DECAL**

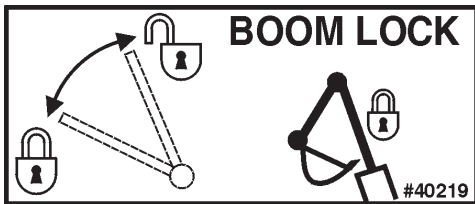

**PART #40219
BOOM LOCK DECAL**

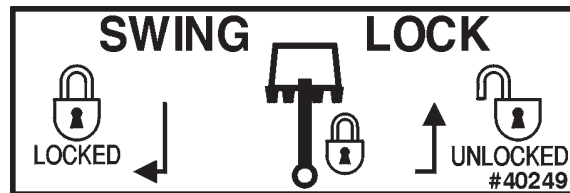

**PART #40249
SWING LOCK DECAL**

DECALS

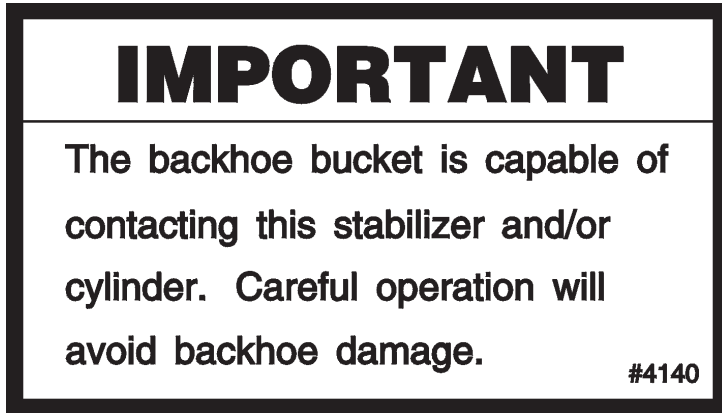

PART #4140
BUCKET CONTACT WARNING DECAL



PART #4338
MADE IN U.S.A. DECAL



PART #40440
CALL BEFORE YOU DIG



PART #4084
GREASE 8 HOURS