

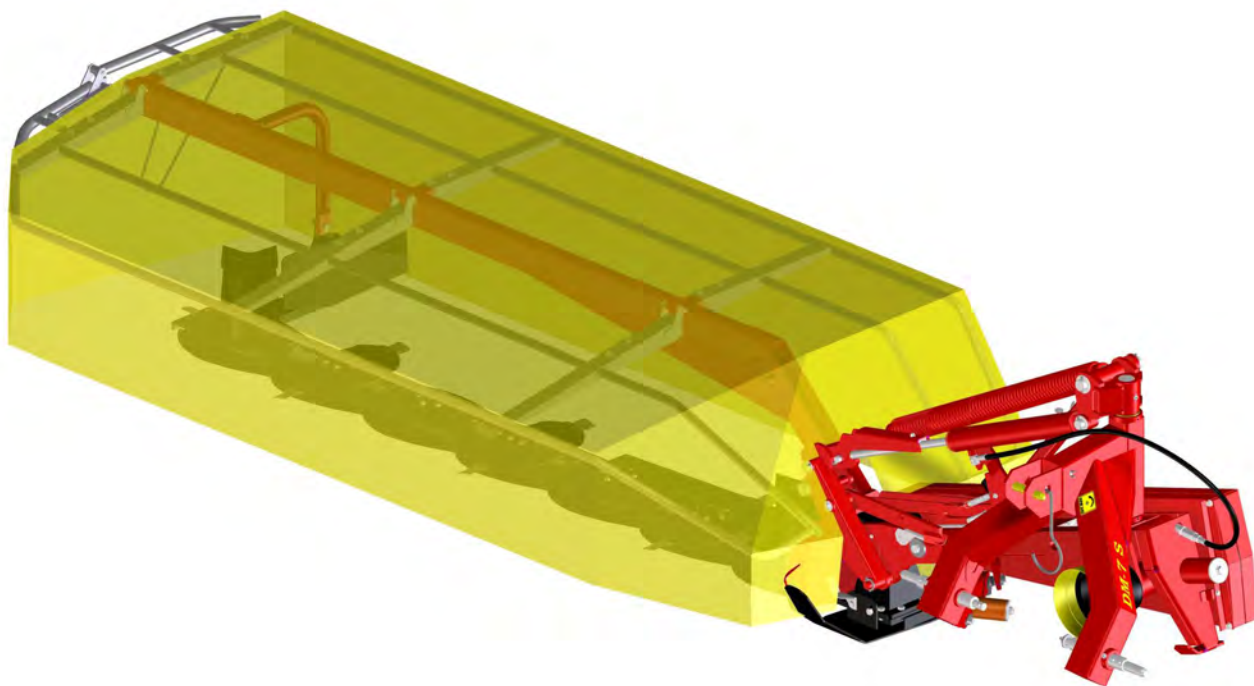

AGRICULTURAL MACHINERY  
**sitrex**®  
Spa

**ASSEMBLY, USE AND  
MAINTENANCE  
SPARE PARTS LIST**



**DM 6-7-8 S**



---

## TABLE OF CONTENT

SECTION 1	SPARE PARTS LIST	1
SECTION 2	GENERAL INFORMATION	29
2.1	WARRANTY	29
SECTION 3	GUIDE TO THE SIGNS AND SYMBOLS USED IN THIS MANUAL AND THEIR LOCATION ON THE MACHINE	30
3.1	SIGNS AND SYMBOLS	30
3.2	WARNING AND DANGER SIGNS	30
3.3	INDICATION SIGNS	31
SECTION 4	GENERAL SUMMARY OF SAFETY AND ACCIDENT - PREVENTION INSTRUCTIONS	32
4.1	GENERAL SUMMARY OF SAFETY AND ACCIDENT-PREVENTION INSTRUCTIONS	32
SECTION 5	PRODUCT IDENTIFICATION	35
5.1	TRACTOR REQUIREMENTS	35
5.2	MACHINE TECHNICAL DATA	35
5.3	MACHINE IDENTIFICATION DATA	35
SECTION 6	ASSEMBLY	36
6.1	TECHNICAL NOTES	36
6.2	INSTRUCTIONS ON HOW TO ASSEMBLE	37
SECTION 7	INSTRUCTIONS FOR INSTALLATION AND USE	46
7.1	HOW TO ADAPT TO THE TRACTOR	46
7.2	Adjustment of the height of the frame above the ground	47
7.3	HOW TO ADAPT THE CARDAN SHAFT	48
7.4	PUTTING IN THE TRANSPORT POSITION	49
7.5	PUTTING IN THE WORK POSITION	50
7.6	USE OF THE DISC MOWER	51
7.7	HOW TO DISCONNECT THE MACHINE	52
SECTION 8	ADJUSTMENTS AND SET-UP	53
8.1	BELT TENSION	53
8.2	CUTTING HEIGHT	53
8.3	HYDRAULIC FLOW ADJUSTER	53
8.4	SPRING TENSION	54
8.5	SAFETY DEVICE	54
SECTION 9	FAULTS: REASONS AND REMEDIES	55
9.1	The disk carrier bar vibrates too much during work:	55
9.2	The disk carrier bar does not adapt correctly to uneven ground:	55
9.3	The disk carrier bar is not raised parallel to the ground:	55
9.4	7.4 Earth accumulates between two sliding blocks in the front part of the disk carrier bar	55
9.5	Safety device (fig. 8.5) often unhooks under impact:	55
9.6	The stubble is too high or too sparse:	55
9.7	The stubble is not the same height all along the cutting width:	55
9.8	The forage is pushed forward before being cut:	55
SECTION 10	MAINTENANCE	56
10.1	HOW TO FASTEN CUTTING DEVICES	56
10.2	HOW TO CHECK THE MOWING DEVICES	57
10.3	GENERAL MAINTENANCE	57
10.4	LUBRICATION	58
10.5	END OF SEASON STORAGE	59

---



SECTION 1 SPARE PARTS LIST

DM6 TABLE NO. 910.148

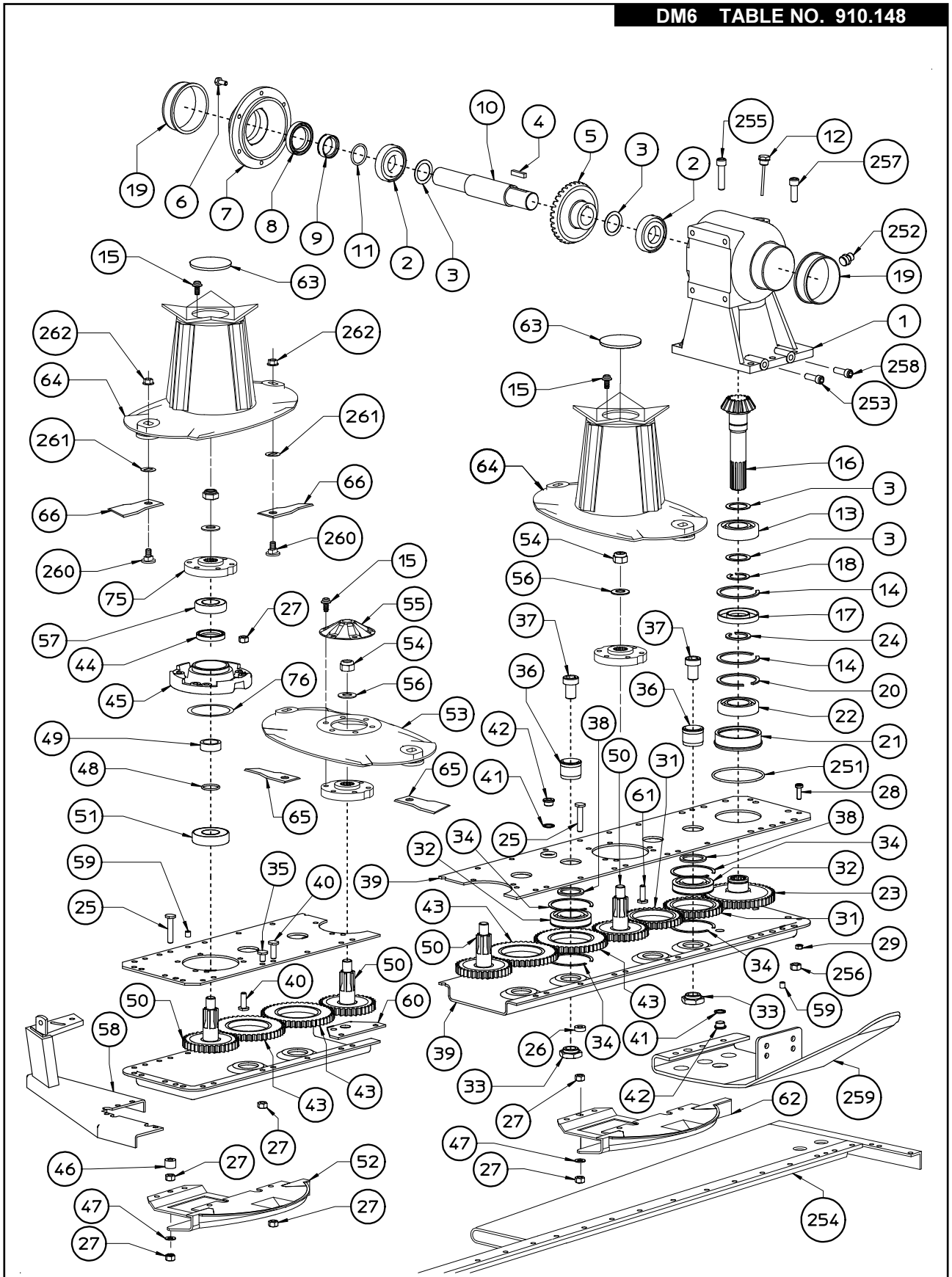

TABLE NO. 910.148				
DM-6				
ITEM	Q.TY	PART/NO	DESCRIPTION	NOTE
1	1	100.882	GEAR BOX CASING	
2	2	620.129	BEARING	
3	4	100.883	WASHER	
4	1	620.141	TAB	
5	1	100.772	BEVEL GEAR	
6	8	620.130	SCREW	
7	1	100.770	COVER	
8	1	620.156	OIL SEAL	
9	1	100.884	BUSH	
10	1	100.771	DRIVING SHAFT	
11	1	620.171	RING OR	
12	1	100.774	PLUG	
13	1	620.172	BEARING	
14	2	620.148	SNAP RING	
15	36	620.244	SCREW	
16	1	100.773	SPROCKET	
17	1	620.161	SEAL	
18	1	620.145	RING	
19	2	610.232	BUSH	
20	1	620.148	SNAP RING	
21	1	100.885	BEARING BUSH	
22	1	620.173	BEARING	
23	1	100.779	GEAR	
24	1	620.146	SNAP RING	
25	6	100.783	SCREW	
26	4	100.792	DISTANCE	
27	102	620.136	NUT	
28	4	620.131	SCREW	
29	4	620.174	NUT	
31	2	100.801	GEAR	
32	12	620.126	BEARING	
33	12	100.798	NUT	
34	24	100.804	SNAP RING	
35	24	100.787	SCREW	
36	12	100.797	DISTANCE PIN	
37	12	100.786	SCREW	
38	12	100.785	DISTANCE	
39	1	100.887	SUPPORT (UPPER+LOWER)	
40	62	100.782	SCREW	
41	3	620.175	WASHER	
42	3	100.789	PLUG	
43	10	100.802	GEAR	
44	6	620.159	SEAL	
45	6	100.799	DISC SUPPORT	
46	2	100.793	DISTANCE	

TABLE NO. 910.148				
DM-6				
ITEM	Q.TY	PART/NO	DESCRIPTION	NOTE
47	6	100.795	WASHER	
48	6	620.165	RING OR	
49	6	100.803	BUSH	
50	6	100.800	GEAR	
51	6	620.176	BEARING	
52	5	100.995	SUPPORT	
53	4	110.463	DISC	
54	6	620.139	NUT	
55	4	100.996	COVER	
56	6	620.150	WASHER	
57	6	620.128	BEARING	
58	1	110.127	SUPPORT DEFLEKTOR	
59	2	620.143	SPRING PIN	
60	1	100.890	HOOK	
61	4	100.790	SCREW	
62	1	110.001	SUPPORT	
63	2	100.791	PLUG	
64	2	110.464	DISC CONVEY	
65	6	100.367	CLOCK-WISE KNIFE	
66	6	100.366	CONTERCLOCK-WISE KNIFE	
75	6	100.993	SUPPORT	
251	1	620.164	RING OR	
252	1	620.152	PLUG	
253	1	620.245	SCREW	
254	1	110.380	REAR REINFORCEMENT	
255	3	620.243	SCREW	
256	8	620.137	NUT	
257	5	620.133	SCREW	
258	1	620.134	SCREW	
259	1	100.986	SUPPORT	
260	12	100.796	SCREW	
261	12	100.821	WASHER	
262	12	100.794	NUT	

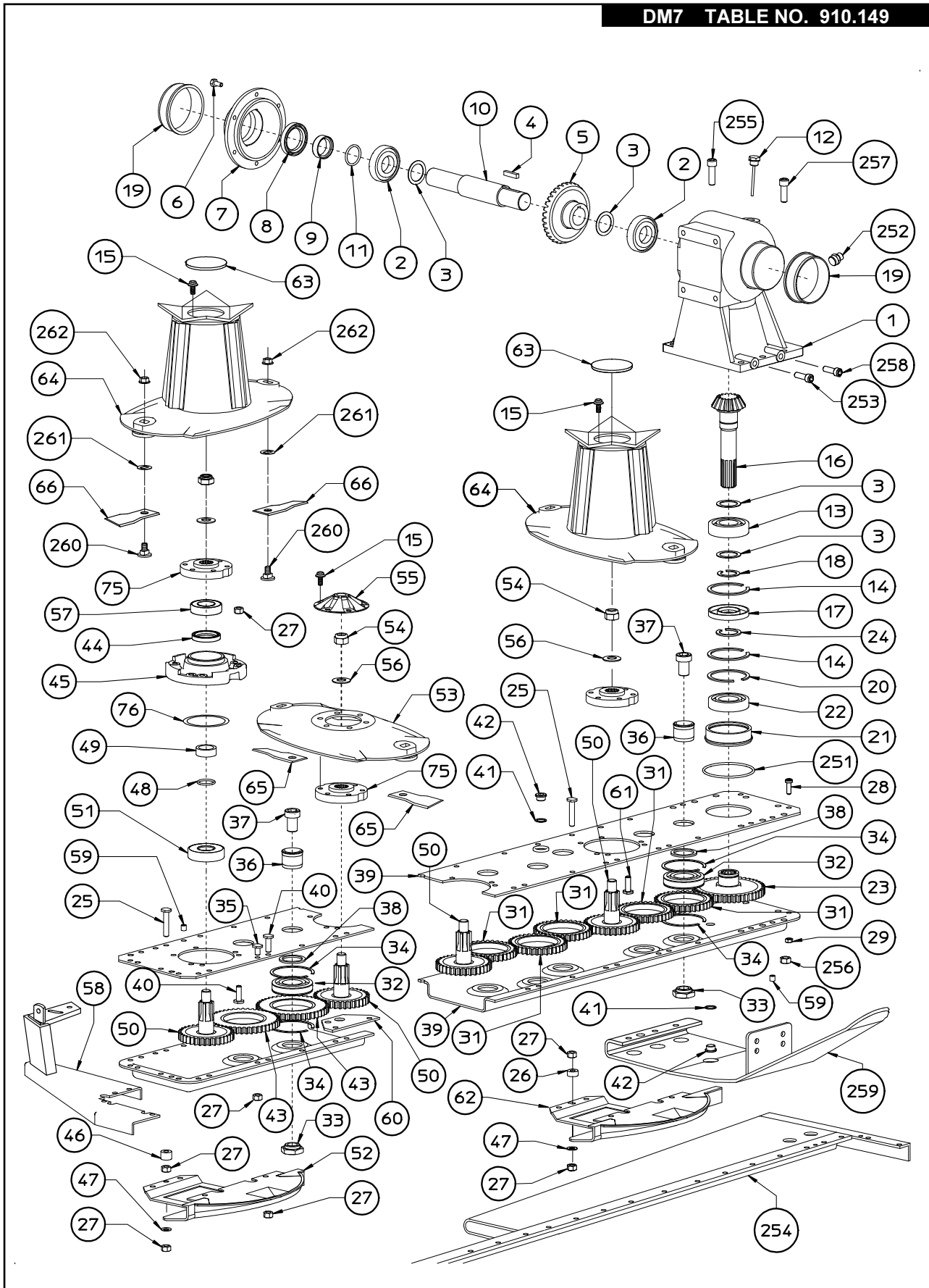

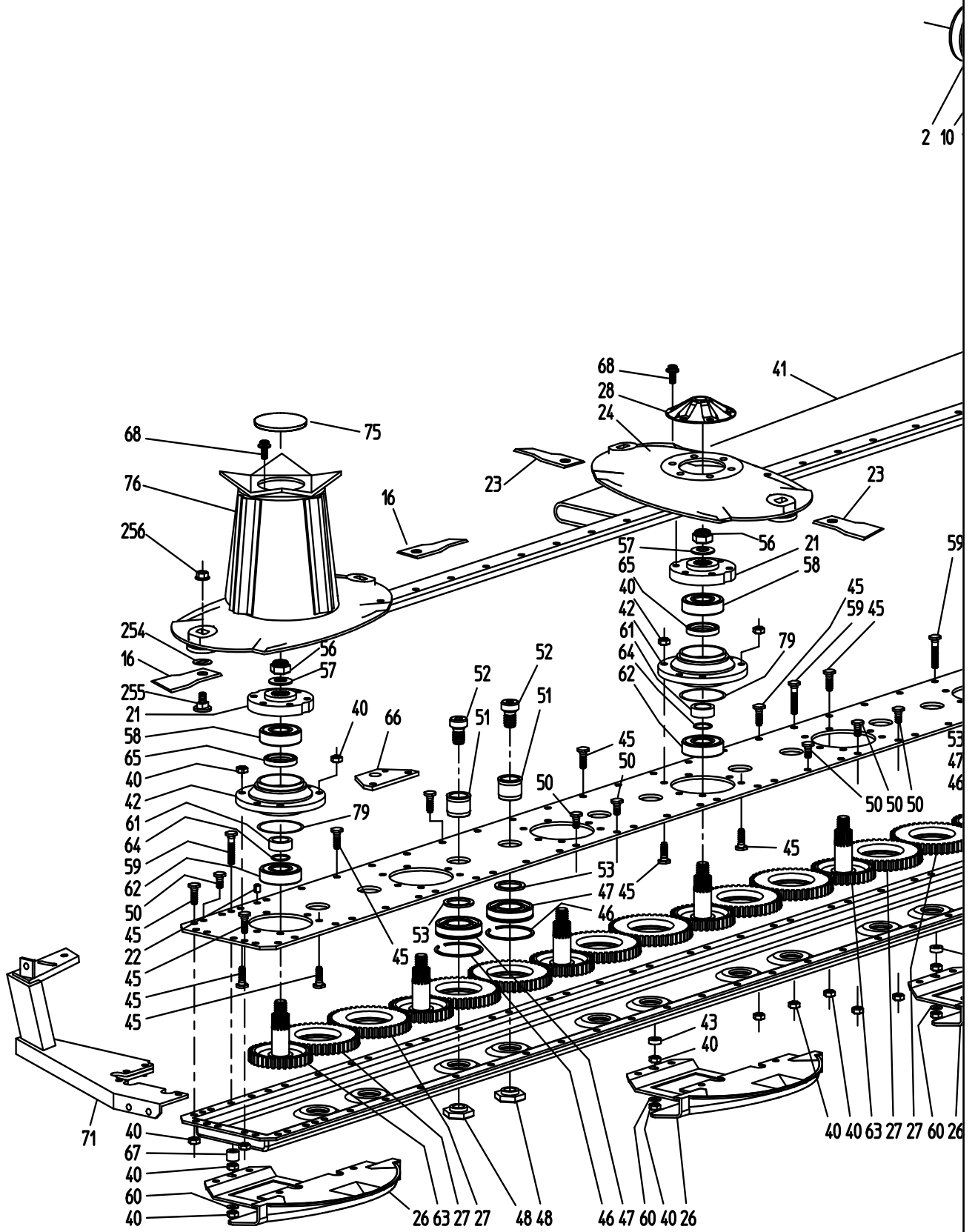

TABLE NO. 910.149				
DM-7				
ITEM	Q.TY	PART/NO	DESCRIPTION	NOTE
1	1	100.992	GEAR BOX CASING	
2	2	620.129	BEARING	
3	4	100.883	WASHER	
4	1	620.141	TAB	
5	1	100.772	BEVEL GEAR	
6	8	620.130	SCREW	
7	1	100.770	COVER	
8	1	620.156	OIL SEAL	
9	1	100.884	BUSH	
10	1	100.771	DRIVING SHAFT	
11	1	620.171	RING OR	
12	1	100.774	PLUG	
13	1	620.172	BEARING	
14	2	620.148	SNAP RING	
15	42	620.244	SCREW	
16	1	100.773	SPROCKET	
17	1	620.161	SEAL	
18	1	620.145	RING	
19	2	610.232	BUSH	
20	1	620.148	SNAP RING	
21	1	100.885	BEARING BUSH	
22	1	620.173	BEARING	
23	1	100.779	GEAR	
24	1	620.146	SNAP RING	
25	7	100.783	SCREW	
26	4	100.792	SCREW	
27	118	620.136	NUT	
28	4	620.131	SCREW	
29	4	620.174	NUT	
31	5	100.801	GEAR	
32	15	620.126	BEARING	
33	15	100.798	NUT	
34	30	100.804	SNAP RING	
35	31	100.787	SCREW	
36	15	100.797	DISTANCE PIN	
37	15	100.786	SCREW	
38	15	100.785	DISTANCE	
39	1	100.886	SUPPORT (UPPER+LOWER)	
40	71	100.782	SCREW	
41	3	620.175	WASHER	
42	3	100.789	PLUG	
43	10	100.802	GEAR	
44	7	620.159	SEAL	
45	7	100.799	DISC SUPPORT	
46	6	100.793	DISTANCE	

TABLE NO. 910.149				
DM-7				
ITEM	Q.TY	PART/NO	DESCRIPTION	NOTE
47	7	100.795	WASHER	
48	7	620.165	RING OR	
49	7	100.803	BUSH	
50	7	100.800	GEAR	
51	7	620.176	BEARING	
52	5	100.995	SUPPORT	
53	5	110.463	DISC	
54	7	620.139	NUT	
55	5	100.996	COVER	
56	7	620.150	WASHER	
57	7	620.128	BEARING	
58	1	110.127	SUPPORT DEFLEKTOR	
59	2	620.143	SPRING PIN	
60	1	100.890	HOOK	
61	7	100.790	SCREW	
62	2	110.001	SUPPORT	
63	2	100.791	PLUG	
64	2	110.464	DISC CONVEY	
65	8	100.367	CLOCK-WISE KNIFE	
66	6	100.366	CONTERCLOCK-WISE KNIFE	
75	7	100.993	SUPPORT	
251	1	620.164	RING OR	
252	1	620.152	PLUG	
253	1	620.245	SCREW	
254	1	110.379	REAR REINFORCEMENT	
255	3	620.243	SCREW	
256	8	620.137	NUT	
257	5	620.133	SCREW	
258	2	620.134	SCREW	
259	1	100.986	SUPPORT	
260	14	100.796	SCREW	
261	14	100.821	WASHER	
262	14	100.794	NUT	



DM8 S TABLE NO. 910.147



DM8 S TABLE NO. 910.147

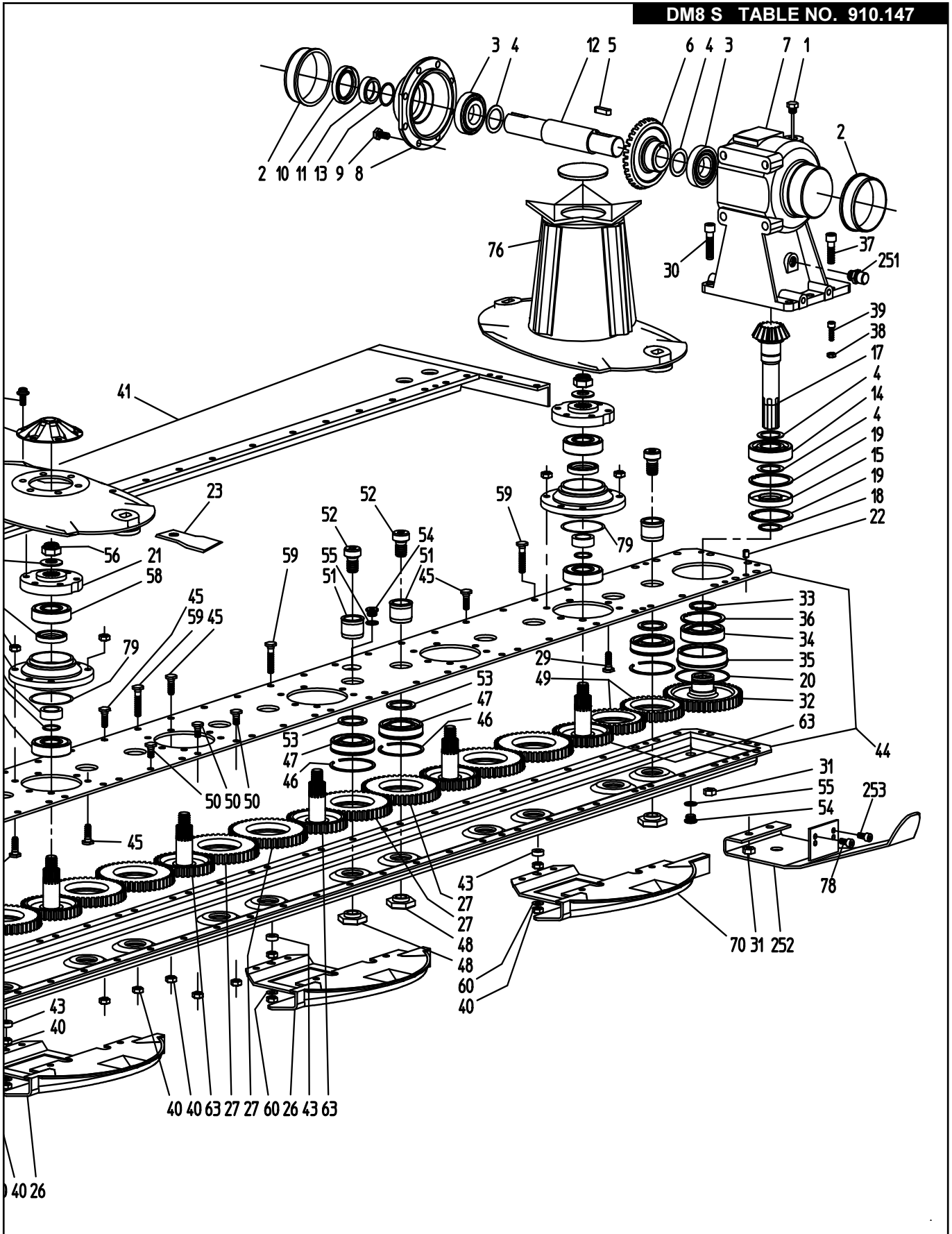

DM8 S TABLE NO. 910.147				
Item Pos.	Part No. Code	Q.tè Q.ty	DESCRIPTION	NOTE
1	100.774	1	PLUG	
2	610.232	2	BUSHING	
3	620.129	2	BEARING	
4	100.883	4	WASHER	
5	620.141	1	TAB	
6	100.772	1	BEVEL GEAR	
7	100.992	1	GEAR BOX CASING	
8	100.770	1	COVER	
9	620.130	8	SCREW	
10	620.156	1	OIL SEAL	
11	100.884	1	BUSH	
12	100.771	1	DRIVING SHAFT	
13	620.171	1	RING OR	
14	620.172	1	BEARING	
15	620.161	1	SEAL	
16	100.366	8	COUNTERCLOCK-WISE KNIFE	
17	100.773	1	SPROCKET	
18	620.145	1	RING	
19	620.148	2	SNAP RING	
20	620.164	1	O-RING GASKET	
21	100.993	8	DISC SUPPORT	
22	620.143	2	SPRING PIN	
23	100.367	8	CLOCK-WISE KNIFE	
24	110.463	6	CUTTING DISC	
26	100.995	7	SLIDING SUPPORT	
27	100.802	14	GEAR	
28	100.996	1	DISC COVER	
29	100.790	1	SCREW	
30	620.243	3	SCREW	
31	620.137	8	NUT	
32	100.779	1	GEAR	
33	620.146	1	SNAP RING	
34	620.173	1	BEARING	
35	100.885	1	BEARING BUSH	
36	620.148	1	SNAP RING	
37	620.133	5	SCREW	
38	620.174	4	NUT	
39	620.131	4	SCREW	
40	620.136	128	NUT	
41	100.997	1	REAR REINFORCEMENT	
42	110.418	8	BEARING DISC SUPPORT	
43	100.792	6	SPACER	
44	100.998	1	SUPPORT (UPPER+LOWER)	
45	100.782	97	SCREW	
46	100.804	16	SNAP RING	

DM8 S TABLE NO. 910.147				
Item Pos.	Part No. Code	Q.ty Q.tè	DESCRIPTION	NOTE
47	620.126	16	BEARING	
48	100.798	16	NUT	
49	100.801	2	GEAR	
50	100.787	31	SCREW	
51	100.797	16	DISTANCE PIN	
52	100.786	16	SCREW	
53	100.785	16	DISTANCE	
54	100.789	2	PLUG	
55	620.175	2	WASHER	
56	620.139	8	NUT	
57	620.150	8	WASHER	
58	620.128	8	BEARING	
59	100.783	8	SCREW	
60	100.795	8	WASHER	
61	100.803	8	BUSH	
62	620.176	8	BEARING	
63	100.800	8	GEAR	
64	620.165	8	RING OR	
65	620.159	8	SEAL	
66	100.890	1	HOOK	
67	100.793	2	DISTANCE	
68	620.244	48	SCREW	
70	110.001	1	SLIDING SUPPORT	
71	110.127	1	DISC SUPPORT	
75	100.791	2	PLUG	
76	110.464	2	DISC + CONVEY	
77	500.056	1	PLUG	
78	620.245	1	SCREW	
79	630.576	8	RING OR	
251	620.152	1	PLUG	
252	100.986	1	SLIDING SUPPORT	
253	620.134	1	SCREW	
254	100.821	16	WASHER	
255	100.796	16	SCREW	
256	100.794	16	NUT	

TABLE NO. 910.150

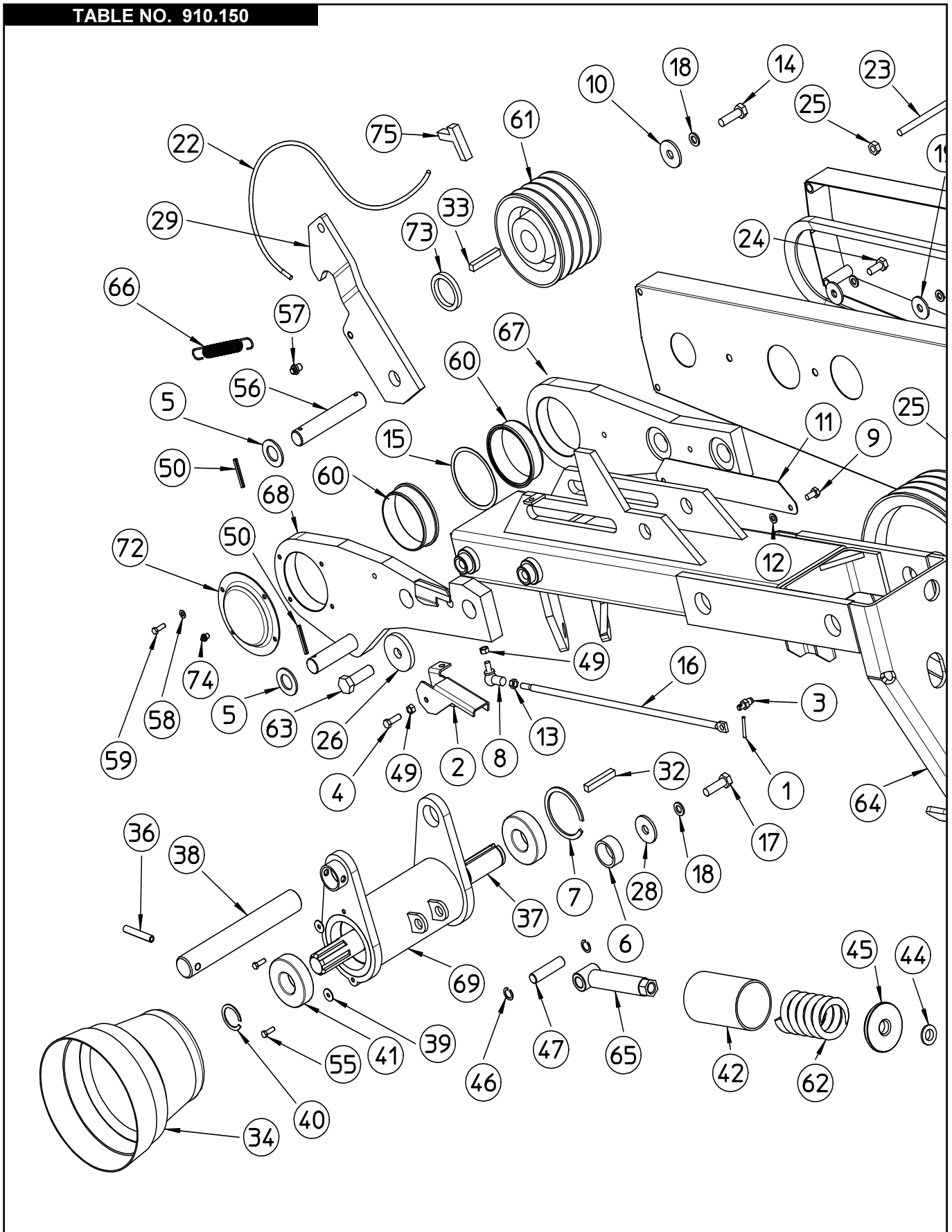



TABLE NO. 910.150

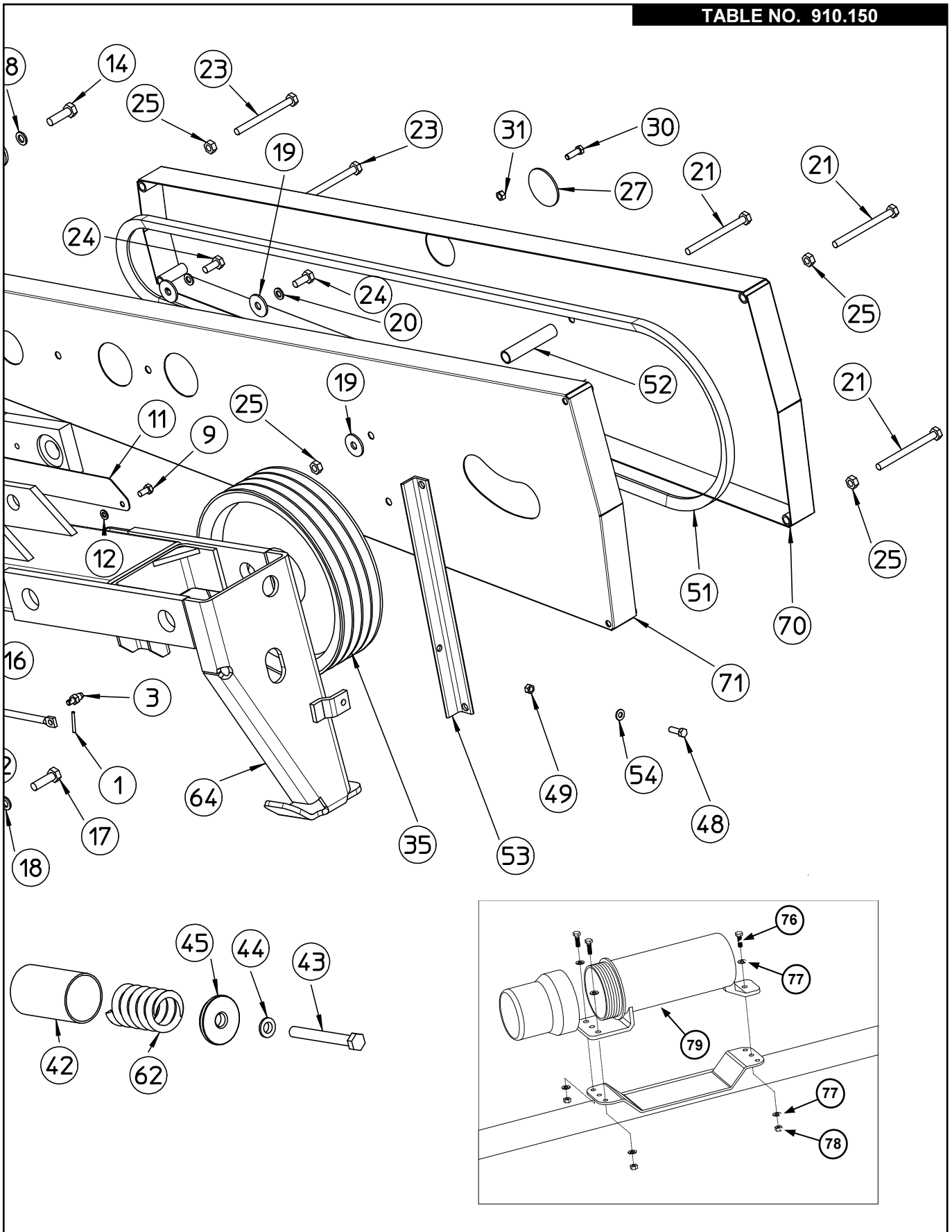

TABLE NO. 910.150			
Item Pos.	Part No. Code	DESCRIPTION	NOTE
1	600.306	PLUG	
2	110.429	LEVER	
3	110.486	PIN	
4	600.551	SCREW	
5	110.493	WASHER	
6	110.482	SPACER	
7	620.480	SNAP RING	
8	630.931	BALL JOINT M8	
9	600.061	SCREW	
10	110.487	WASHER	
11	110.476	PROTECTION	
12	600.229	WASHER	
13	600.037	NUT	
14	620.475	SCREW	
15	100.352	SHIM	
16	110.477	TIE ROD	
17	630.967	SCREW	
18	600.018	SPRING WASHER	
19	620.250	WASHER D.11	
20	600.024	WASHER	
21	600.206	SCREW M10x120	
22	610.160	ROPE	
23	110.021	SCREW	
24	600.006	SCREW	
25	600.029	NUT	
26	110.423	WASHER	
27	100.313	PLUG	
28	110.487	WASHER	
29	110.424	HOOK	
30	630.100	SCREW	
31	610.718	NUT	
32	630.969	TAB	
33	610.505	TAB	
34	620.442	PDF CAP	
35	100.224	PULLEY	
36	600.540	SPRING PIN	
37	110.478	INPUT SHAFT	
38	100.958	PIN	
39	600.135	WASHER	
40	600.333	SNAP RING	

TABLE NO. 910.150			
Item Pos.	Part No. Code	DESCRIPTION	NOTE
41	620.248	BEARING	
42	100.969	SPACER	
43	620.249	BELT TENSION SCREW	
44	100.970	WASHER	
45	100.968	TIGHTENER WASHER	
46	600.533	RETAINING RING	
47	100.758	PIN	
48	600.702	SCREW	
49	600.076	NUT	
50	640.007	SPRING PIN	
51	620.251	BELT	
52	110.022	SPACER	
53	110.016	BELT COVER SUPPORT	
54	610.185	WASHER	
55	620.278	SCREW (M6x16 5739-ZN)	
56	110.426	PIN	
57	220.159	PIN	
58	600.514	FLAT WASHER	
59	630.003	SCREW	
60	610.232	BUSH	
61	100.225	PULLEY	
62	100.967	PTO SPRING	
63	610.510	SCREW	
64	110.420	FRAME	
65	100.965	TIGHTENER ROD	
66	110.425	SPRING	
67	110.421	GEARBOX SUPPORT	
68	110.422	GEARBOX SUPPORT	
69	110.479	PTO SUPPORT	
70	100.964	BELT REAR COVER	
71	110.427	BELT FRONT COVER	
72	110.488	COVER	
73	110.015	SHIM	
74	600.124	GREASE NIPPLE	
75	620.357	HANDLE	
76	630.003	SCREW M6 X 20	
77	600.135	FLAT WASHER $\varnothing 6,6 \times 18$	
78	600.472	NUT M6 DIN 980	
79	230.457	CANISTER	

TABLE NO. 910.151

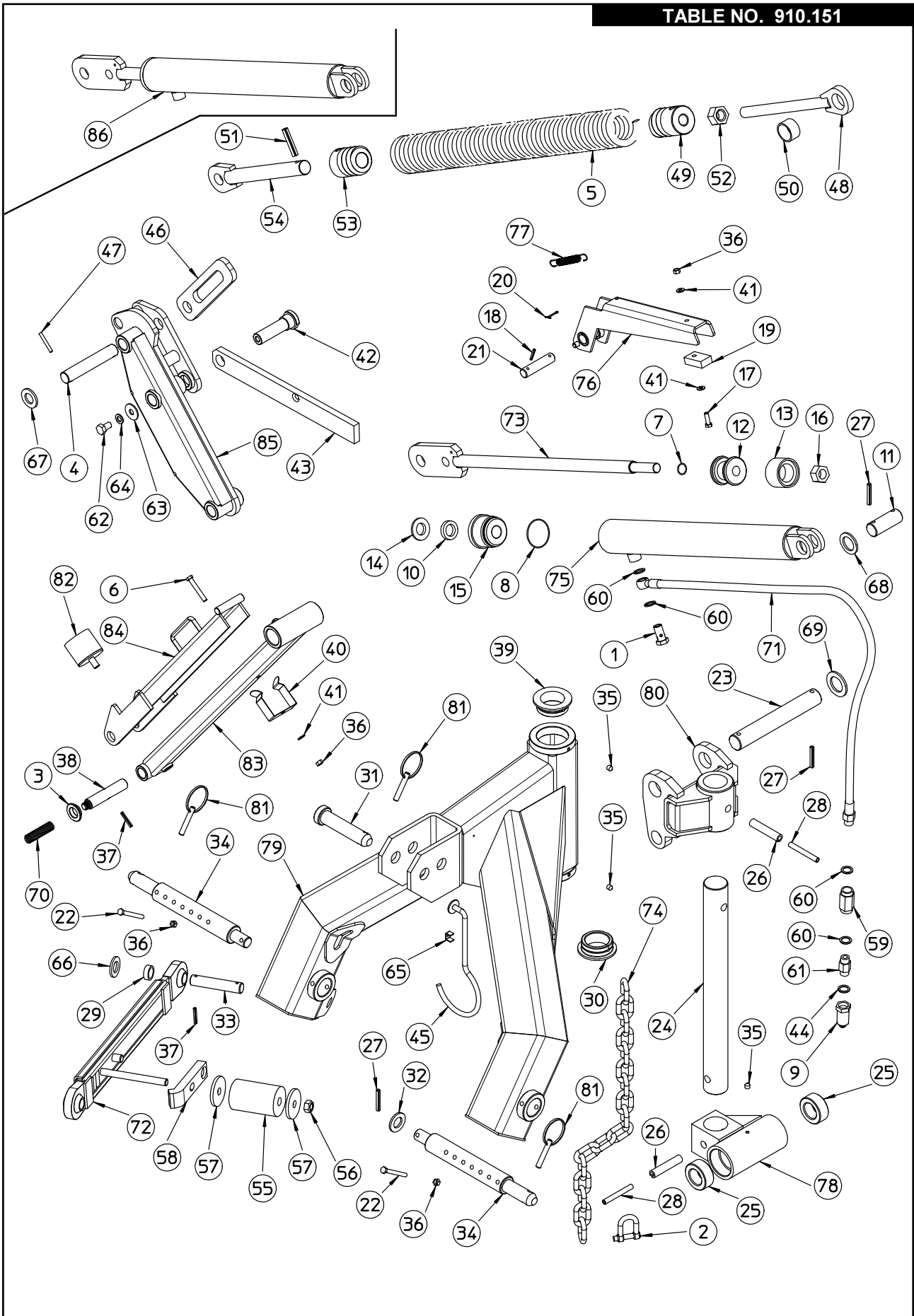

TABLE NO. 910.151			
Item Pos.	Part No. Code	DESCRIPTION	NOTE
1	600.040	FITTING D 3/8	
2	610.118	SHACKLES	
3	110.475	SPACER	
4	110.459	PIN	
5	100.979	SPRING PIN	
6	630.005	SCREW	
7*	--	O RING	
8*	--	O RING	
9	600.273	QUICK COUPLING	
10*	--	GASKET	
11	110.447	PIN	
12	110.495	PISTON	
13*	--	GASKET	
14*	--	GASKET	
15	110.470	CYLINDER HEAD	
16	631.383	NUT	
17	600.702	SCREW	
18	600.182	SPRING PIN	
19	110.450	NYLON PROTECTION	
20	600.112	SPLIT PIN	
21	110.449	PIN	
22	600.400	SCREW	
23	110.445	PIN	
24	100.954	PIN	
25	110.480	BUSHING	
26	620.247	SPRING PIN	
27	600.027	SPRING PIN	
28	600.033	PIN	
29	110.398	BUSHING	
30	110.484	BUSHING	
31	110.011	3 POINT HITCH PIN	
32	600.336	WASHER	
33	110.455	PIN	
34	100.951	PIN	
35	600.124	GREASE NIPPLE	
36	600.076	NUT	
37	600.538	SPRING PIN	
38	110.454	PIN	
39	100.953	BUSHING	
40	110.453	LOCKING SPRING	
41	600.115	WASHER	
42	110.483	PIN	
43	110.458	ROD	
44	630.048	WASHER	
45	100.253	SUPPORT	
*	630.950	CYLINDER GASKET SET	

TABLE NO. 910.151

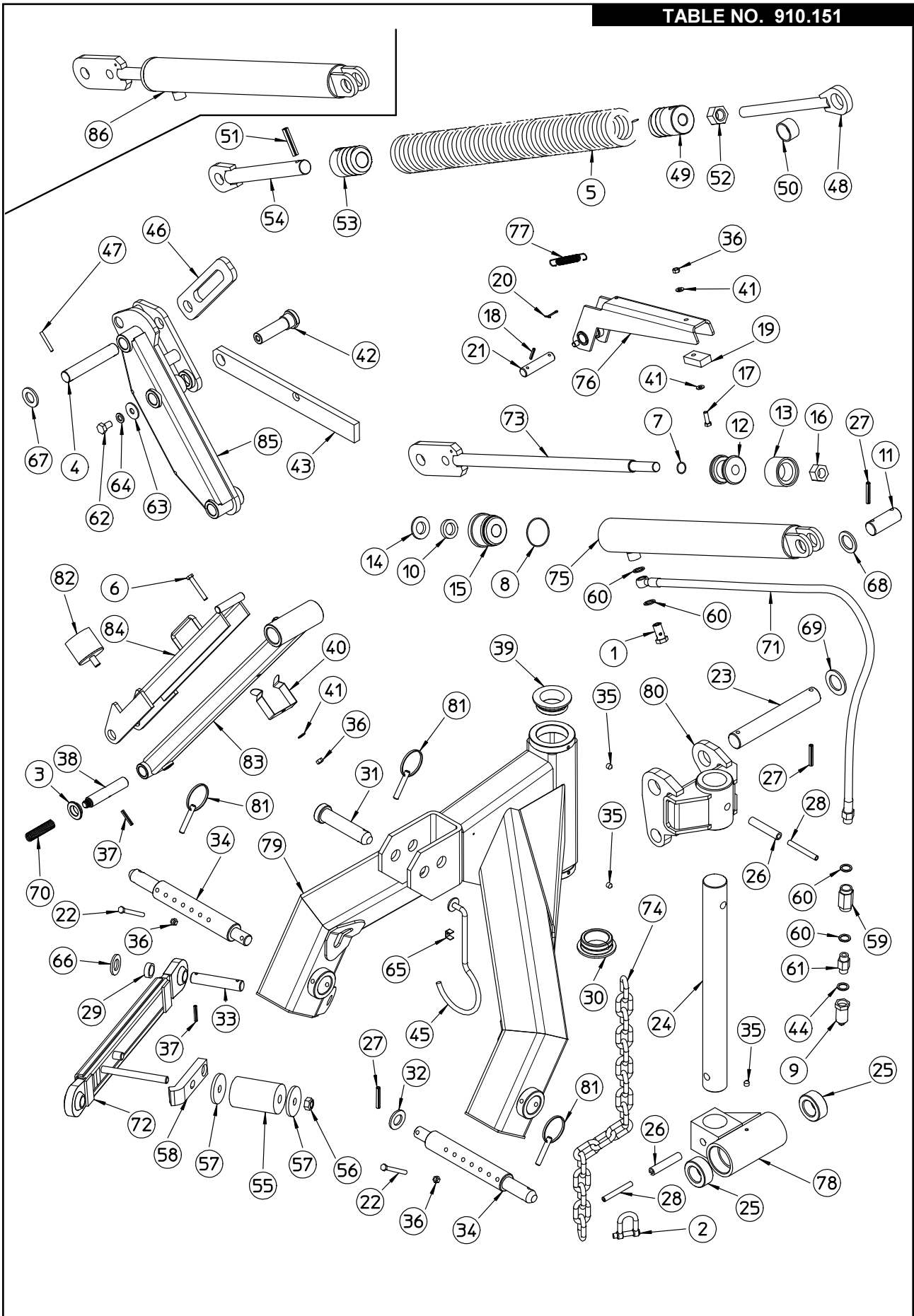

TABLE NO. 910.151			
Item Pos.	Part No. Code	DESCRIPTION	NOTE
46	110.457	ROD PLATE	
47	600.539	SPRING PIN	
48	100.977	SPRING SUPPORT	
49	100.978	SPRING HEAD	
50	100.976	SPACER	
51	620.252	SPRING PIN	
52	600.200	NUT	
53	100.980	SPRING HEAD	
54	100.981	SPRING SUPPORT	
55	110.009	RUBBER SPRING	
56	600.075	NUT	
57	110.010	WASHER	
58	100.168	HOOK	
59	610.144	VALVE	
60	620.452	WASHER	
61	600.416	UNION CONN. 3/8-1/2	
62	600.441	SCREW	
63	600.845	WASHER	
64	600.018	SPRING WASHER	
65	200.992	CLIP	
66	600.042	WASHER	
67	110.493	WASHER	
68	110.135	WASHER	
69	110.494	WASHER	
70	110.485	SPRING	
71	630.949	HOSE	
72	110.003	SAFETY ROD	
73	110.469	CYLINDER ROD	
74	110.367	CHAIN	
75	110.468	CYLINDER BARREL	
76	110.448	CYLINDER STOP	
77	220.123	SPRING	
78	100.956	PIVOTING SUPPORT	
79	110.443	3 POINT HITCH	
80	110.444	HEAD SUPPORT	
81	600.017	PIN	
82	630.968	RUBBER	
83	110.451	TIE ROD	
84	110.452	TIE ROD	
85	110.456	LEVER	
86	110.446	CYLINDER, COMPLETE	

TABLE NO. 910.152

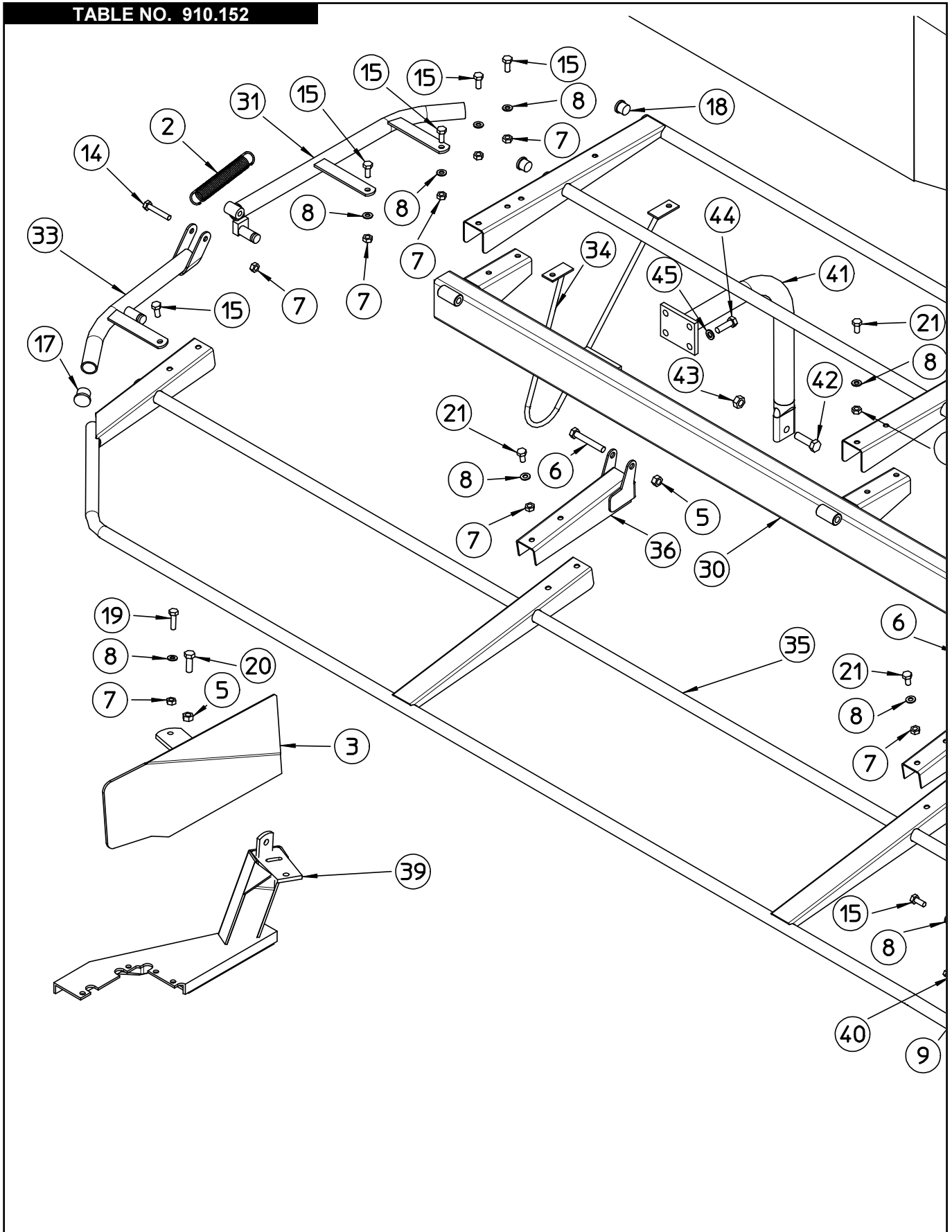



TABLE NO. 910.152

DM7 S ONLY

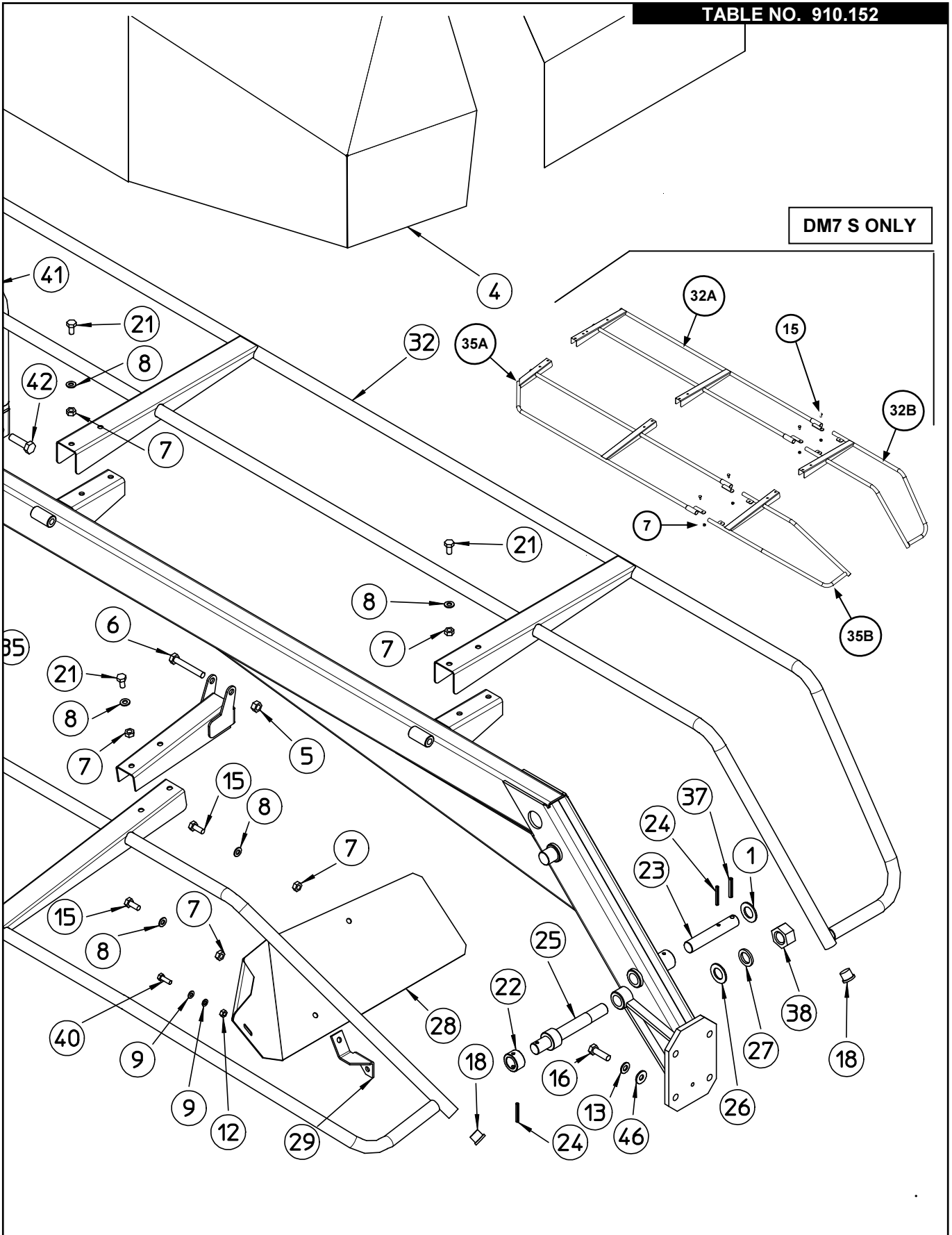
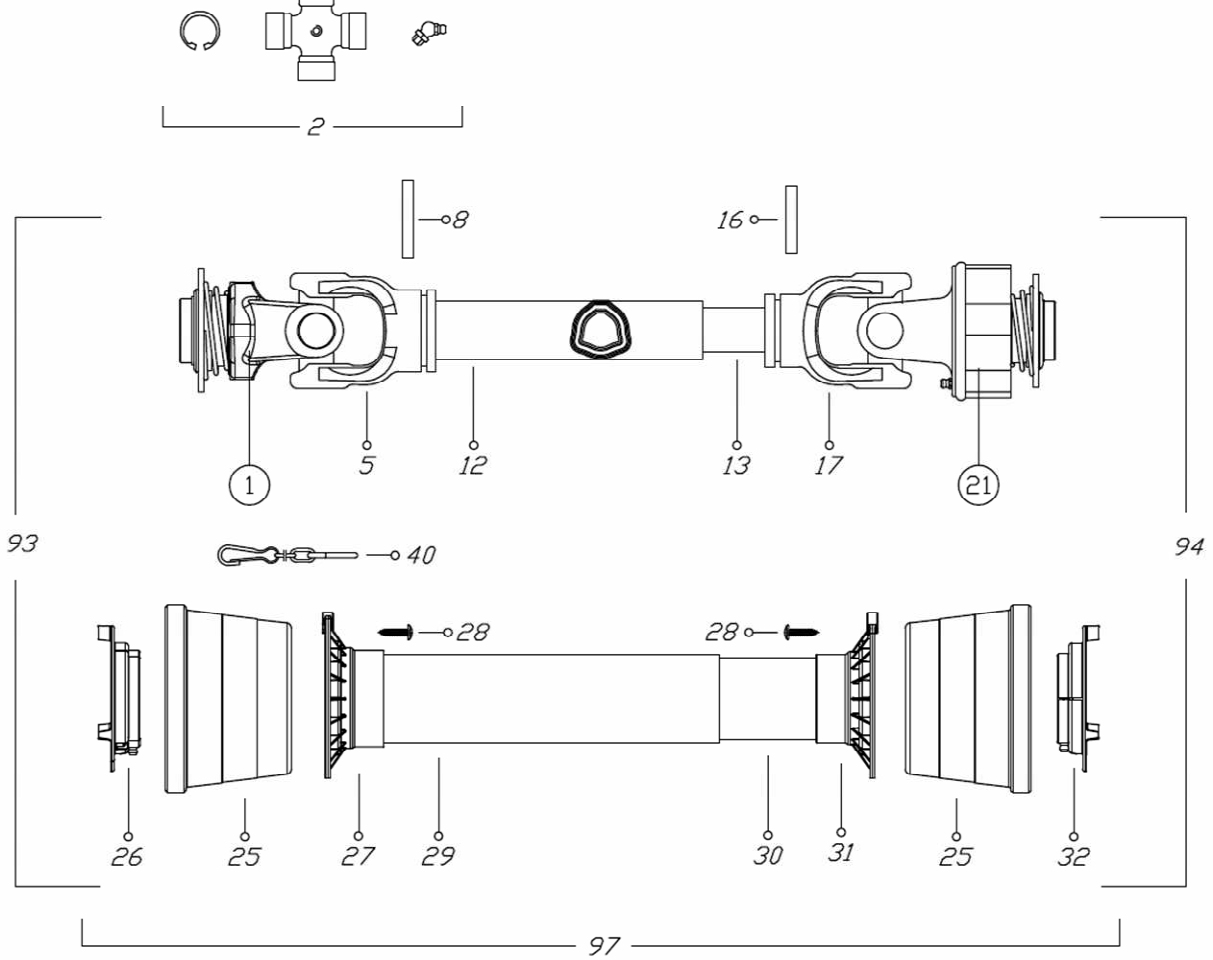

TABLE NO. 910.152			
Item Pos.	Part No. Code	DESCRIPTION	NOTE
1	110.493	WASHER	
2	200.279	SPRING	
3	110.465	HAY DEFLECTOR	
4	110.442	COVER CANVAS	DM6
	110.441	COVER CANVAS	DM7
	110.012	COVER CANVAS	DM8
5	600.077	NUT	
6	600.826	SCREW	
7	600.029	NUT	
8	600.322	WASHER	
9	610.185	WASHER	
12	600.076	NUT	
13	600.018	SPRING WASHER	DM6
	600.086	SPRING WASHER	DM7 - DM8
14	610.500	SCREW	
15	600.006	SCREW	
16	630.839	SCREW	DM6
	620.322	SCREW	DM7 - DM8
17	200.309	PLUG	
18	600.854	PLUG	
19	600.641	SCREW	
20	600.616	SCREW	
21	600.227	GALVANIZED SCREW M10X20	
22	110.432	BUSH	
23	110.433	PIN	
24	600.539	SPRING PIN	
25	110.140	PIN	
26	600.336	WASHER	
27	600.246	WASHER	
28	110.491	HAY DEFLECTOR	
29	110.013	PLATE DEFLECTOR SUPPORT	
30	110.431	FRAME	DM6
	110.430	FRAME	DM7
	110.497	FRAME	DM8
31	100.991	PROTECTION	
32	110.438	PROTECTION	DM6
	100.989	PROTECTION	DM8
32A	120.002	PROTECTION PART RH	DM7
32B	120.004	PROTECTION PART LH	DM7
33	100.990	PROTECTION	
34	110.440	EXTERNAL PROTECTION	
35	110.435	PIVOTING PROTECTION	DM6
	100.988	PIVOTING PROTECTION	DM8
35A	110.997	PIVOTING PROTECTION PART RH	DM7
35B	110.999	PIVOTING PROTECTION PART LH	DM7
36	100.987	PROTECTION PIVOTING	
37	600.027	SPRING PIN	
38	620.319	NUT	
39	110.127	EXTERNAL SUPPORT	
40	600.702	SCREW	
41	100.985	SUPPORT	
42	640.023	SCREW	
43	600.009	NUT	
44	600.441	SCREW	
45	600.018	WASHER	
46	600.089	WASHER	DM6
	600.188	WASHER	DM7 - DM8



DM 6-7 S CARDAN SHAFT 630.932 Z6 Tractor takeoff



①

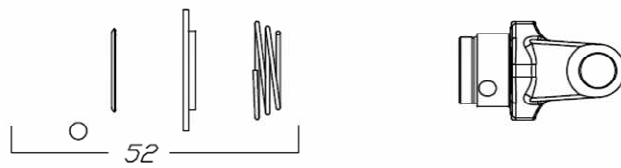

②1

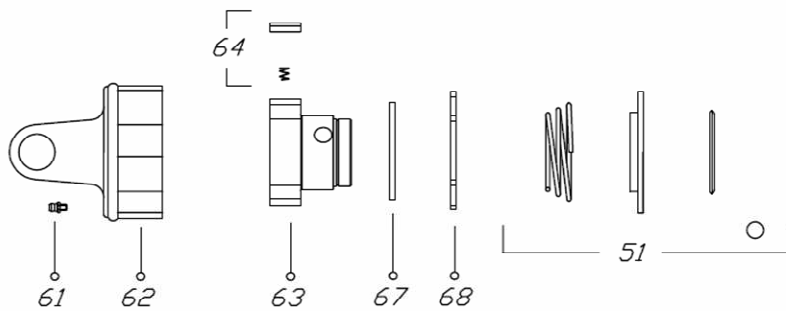

CARDAN SHAFT DM 6-7 S PART NO 630.932 Z6 Tractor takeoff			
Item Pos.	Part No. Code	DESCRIPTION	NOTE
01	630.382	YOKE	Z6 Tractor takeoff
02	610.368	CROSS JOURNAL ASS.	
05	610.370	OUTER TUBE YOKE	
06	001.411	LABEL "DANGER ROTATING ....."	
07	001.316	LABEL "DANGER SHIELD..."	
08	630.383	FLEXIBLE PIN	
12	610.372	CM. 100 CARDAN TUBE(*)	
13	610.373	CM. 100 CARDAN TUBE(*)	
16	630.384	FLEXIBLE PIN	
17	610.375	INNER TUBE YOKE	
21	630.385	FREE WHEEL	
25	630.386	CONE SHIELD BELL 05-06	
26	630.387	OUTER BEARING 05	
27	630.388	OUTER BASE CONE 05-06	
28	630.389	SCREW	
29	630.972	OUTER SAFETY TUBE	
30	630.973	INNER SAFETY TUBE	
31	630.392	INNER BASE CONE 05-06	
32	630.393	INNER BEARING 05	
40	610.068	CHAIN	
51	620.830	BALL COLLAR KITT	
52	630.394	BALL COLLAR KITT	
61	610.206	GRAESE NIPPLE	
62	630.395	OUTER CASING WITH YOKE	
63	630.396	HUIB 1 3/8"z6	
64	620.873	RATCET TOOTH	
67	620.874	RETAINING RING	
68	610.253	CIRCLIP	
93	630.974	OUTER HALF SHAFT	Z6 Tractor takeoff
94	630.975	INNER HALF SHAFT	
97	630.976	SAFETY GUARD	

**DM8 S CARDAN SHAFT 620.237 Z6 Tractor takeoff**

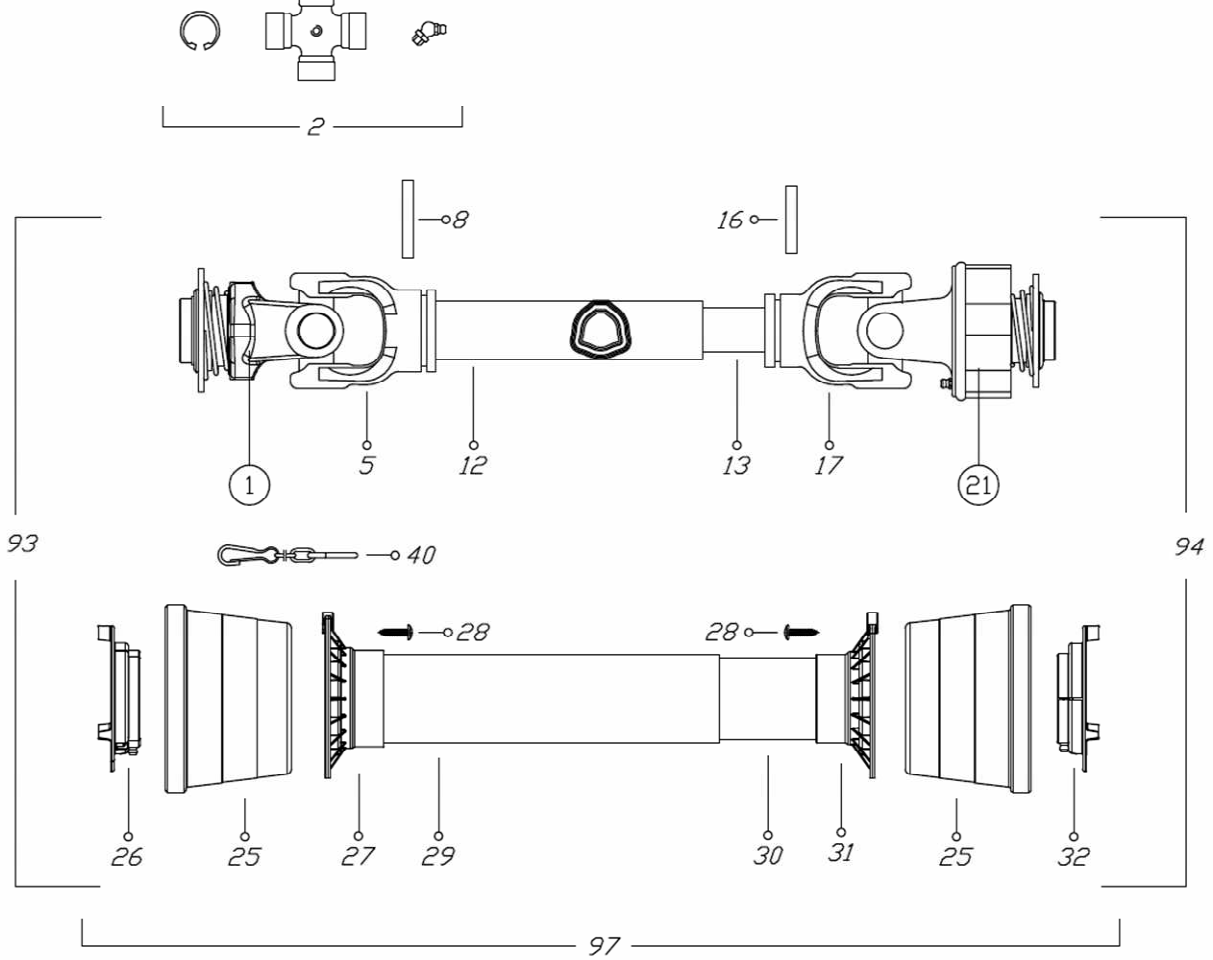

①

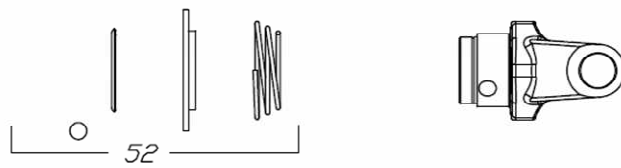

②①

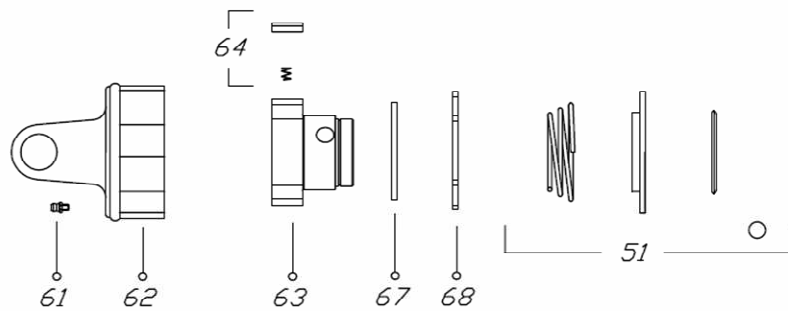

CARDAN SHAFT DM 8 S PART NO. 620.237 Z6			
Item Pos.	Part No. Code	DESCRIPTION	NOTE
01	620.079	YOKE	
02	620.080	CROSS JOURNAL ASS.	
05	620.081	OUTER TUBE YOKE	
08	630.383	FLEXIBLE PIN	
12	620.083	CARDAN TUBE	
13	610.373	CARDAN TUBE	
16	630.384	FLEXIBLE PIN	
17	620.085	INNER TUBE YOKE	
21	630.851	FREE WHEEL	
25	630.386	CONE SHIELD BELL 05-06	
26	630.852	OUTER BEARING	
27	630.388	OUTER BASE CONE 05-06	
28	630.389	SCREW	
29	630.878	OUTER SAFETY TUBE	
30	630.879	INNER SAFETY TUBE	
31	630.392	INNER BASE CONE 05-06	
32	630.880	INNER BEARING	
40	610.068	CHAIN	
48	630.719	LABEL DANGER OUTER DRIVE TUBE	
49	630.720	EXTERNAL SHIELD LABEL	
51	610.057	COMPLETE PUSH BUTTTON	
52	630.394	BALL COLLAR KITT	
71	610.216	GRAESE NIPPLE	
72	620.270	OUTER CASING WITH YOKE	
63	630.396	HUIB 1 3/8"z6	
64	620.873	RATCET TOOTH	
67	620.874	RETAINING RING	
68	610.253	CIRCLIP	
93	620.094	OUTER HALF SHAFT	
94	630.882	INNER HALF SHAFT	
97	630.883	SAFETY GUARD	





## SECTION 2 GENERAL INFORMATION

### 2.1 WARRANTY

The manufacturer warrants new machinery to be free from defects in material and workmanship at the time of delivery to the original purchaser if correctly set up and operated according to this Operator's Handbook.

The manufacturer undertakes to repair or replace free of charge any defective part which should be returned by the purchaser (freight prepaid) and found to be defective on inspection authorized by the manufacturer during the warranty period.

This warranty shall be valid for 12 (twelve) months from the delivery of the goods to the original purchaser.

If the customer is unable to return the defective part to the manufacturer, the manufacturer cannot be held responsible for any cost due for repair or replacement of any part of the machine. He shall only supply the part(s) required for such repair and/or replacement.

The warranty shall be considered null and void when it is evident that the machine has been improperly used or at least repaired without authorization.

The manufacturer shall not be held responsible for any obligation or agreement reached by any manufacturer employers, agents or dealers who do not comply with the above warranty. The manufacturer cannot be held responsible for the subsequent damages. This warranty replaces any other warranty, either explicit or implied, as well as any other obligation of the manufacturer.

#### **NOTE:**

ALL WARRANTY WORK OR REPAIRS MUST BE APPROVED BY THE MANUFACTURER BEFORE WORK BEGIN.

ANY WORK OR REPAIRS MADE BEFORE APPROVAL MAY NOT BE COVERED UNDER WARRANTY.  
PLEASE NOTIFY YOUR SALES & SERVICE DEPARTMENT OF THIS POLICY.

## SECTION 3 GUIDE TO THE SIGNS AND SYMBOLS USED IN THIS MANUAL AND THEIR LOCATION ON THE MACHINE

### 3.1 SIGNS AND SYMBOLS

These signs and symbols give information to the operator on how to make the best use of the machine so as to prolong life, avoid damage, optimise work and, above all, to avoid injury to the operator and anyone within range of the machine

### 3.2 WARNING AND DANGER SIGNS

#### 3.2.1 FIG. 3.1

Read operator's manual and ALL safety instruction



#### 3.2.2 FIG. 3.2

Risk of possible ejection of blunt objects. Keep a safe distance from the machine.



**3.2.3 FIG. 3.3**

Component shielding **MUST** be in place when PTO is engaged.



**3.2.4 FIG. 3.4**

See **HOW TO DISCONNECT THE MACHINE** in this manual.

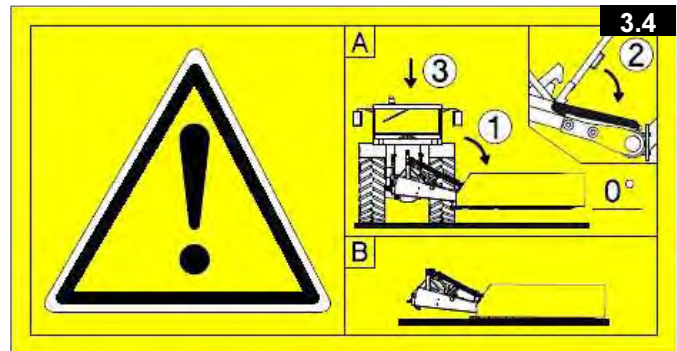

**3.3 INDICATION SIGNS**

**3.3.1 FIG. 3.5**

Indicates a greasing point.

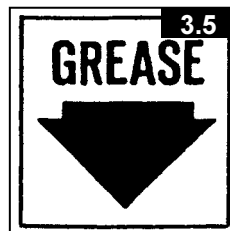

**3.3.3 FIG. 3.7**

Shows the direction of rotation of the power takeoff and the maximum number of revolutions.

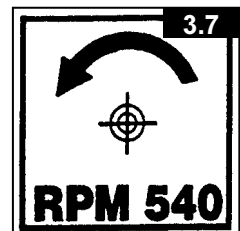

**3.3.2 FIG. 3.6**

This indicates the oil level.

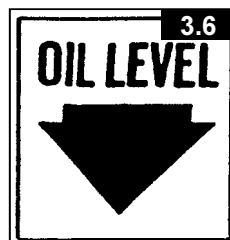

## SECTION 4 GENERAL SUMMARY OF SAFETY AND ACCIDENT - PREVENTION INSTRUCTIONS

### 4.1 GENERAL SUMMARY OF SAFETY AND ACCIDENT-PREVENTION INSTRUCTIONS

Read all the directions carefully before using the machine. When in doubt, seek advice from the manufacturers.

The manufacturing company declines all responsibility for non-compliance with the following safety and accident-prevention instructions.

- 1- Pay attention to the danger signs and symbols in this manual and on the machine.
- 2- Do not touch moving parts.
- 3- All work on the machine (including adjustments) must always be carried out with the tractor immobilized and the engine switched off.
- 4- On no account may persons or animals be carried on the machine.
- 5- Driving the tractor with the machine connected is absolutely forbidden to persons lacking suitable experience, or who are in poor health, or who do not have a suitable driving license.
- 6- All accident-prevention measures recommended in this manual should be scrupulously observed.
- 7- Connecting the machine to the tractor creates a different weight distribution on the axles and so it is essential to ensure that the tractor-machine combination is stable in all anticipated working conditions. It is therefore necessary to have exact instructions from the tractor manufacturers. If such instructions are not available, suitable tests should be conducted in safe conditions in order to assess stability.
- 8- Once the machine is connected, it can only be controlled through a Cardan shaft complete with the required overload protection and guard secured with the appropriate small chains. Be aware of the rotational direction of the Cardan shaft.
- 9- Before operating the tractor and machine, check that all transport and operational safety devices are complete and working.
- 10-When driving on public roads, you should comply with the Highway Code regulations for the country concerned.
- 11-Do not exceed the tractor axle maximum weight and the total mobile weight. Heed transport regulations.
- 12-Before starting work, familiarize yourself with the control devices and how they work.
- 13-Wear suitable clothes. Do not wear clothing which is loose or which could become entangled in rotating or moving parts.
- 14-Connect the machine to a suitably powerful tractor by using an appropriate lifting unit and in accordance with instructions.
- 15-Take maximum care when connecting and disconnecting the machine to and from the tractor.
- 16-The machine and any road transport attachments must bear the appropriate signs and symbols and have suitable protection.
- 17-Never leave the driving seat when the tractor is running.
- 18-It is extremely important to appreciate that road holding, steering and braking may be significantly affected with the machine attached.
- 19-When turning corners with the machine attached, be aware of the fact that the centrifugal force will alter due to the change in the centre of gravity.

- 20-**Before engaging the power takeoff check the preset revolution speed. Do not change speed from 540 rpm to 1000 rpm.

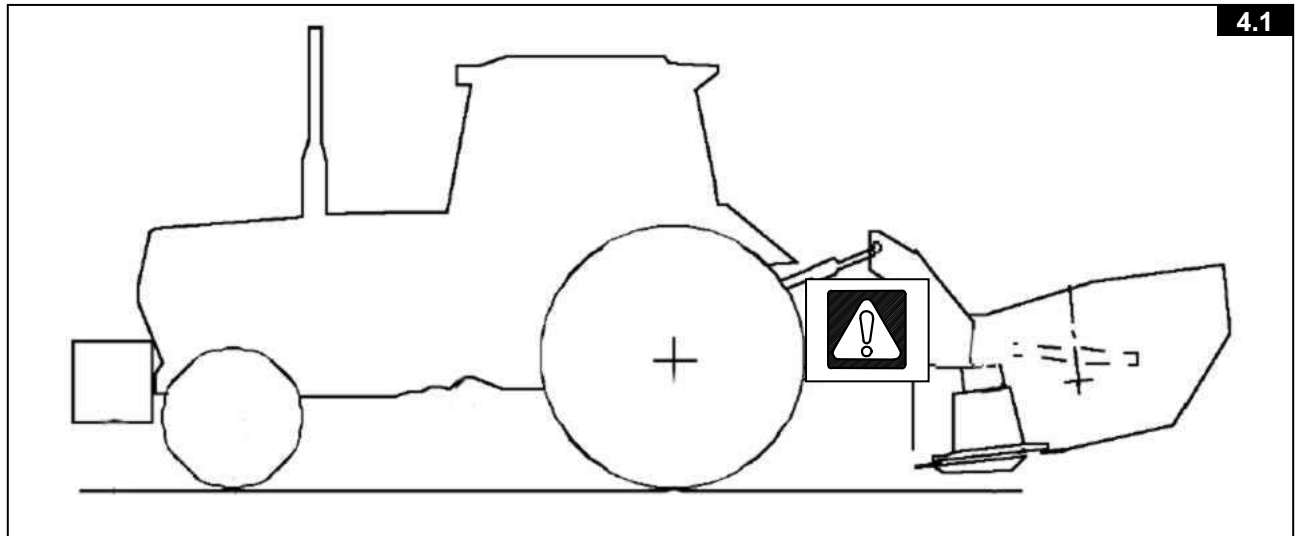

- 21-**Under no circumstances should anybody stand near the machine or any moving parts. It is the duty of the operator to ensure that this requirement is respected.
- 22-**Under no circumstances should anybody go between the tractor and the machine (fig. 4.1) when the engine is running and the Cardan shaft is engaged, especially without first having applied the parking brake and placed chocks against the wheels.
- 23-**Before connecting or disconnecting the machine to or from the 3-point linkage, put the lifting unit lever into the locked position.
- 24-**The connection pins on the machine must match the connection sockets on the lifting unit.
- 25-**During transport, secure the lateral lifting arms with the appropriate chains and tighteners.
- 26-**When the machine is raised during road transport, put the tractor's hydraulic lifter lever into the locked position.
- 27-**Only use the Cardan shaft provided by the manufacturer and, in case of replacement, substitute it with one having the same characteristics.
- 28-**Regularly check all protection on the Cardan shaft. This should always be in excellent condition and securely fixed.

- 29-**It is important to ensure that the protection on the Cardan shaft is complete.

- 30-**Connection and disconnection of the Cardan shaft must be carried out with the engine switched off.

- 31-**Pay particular attention to the correct connection and safety of the Cardan shaft and the power takeoffs on the machine and the tractor.

- 32-**Prevent the cardan shaft protection from rotating using the chains supplied.

- 33-**Before engaging the power takeoff, make sure that there are no people or animals in the vicinity and that the selected engine speed corresponds to that permitted. Never go above the maximum permitted.

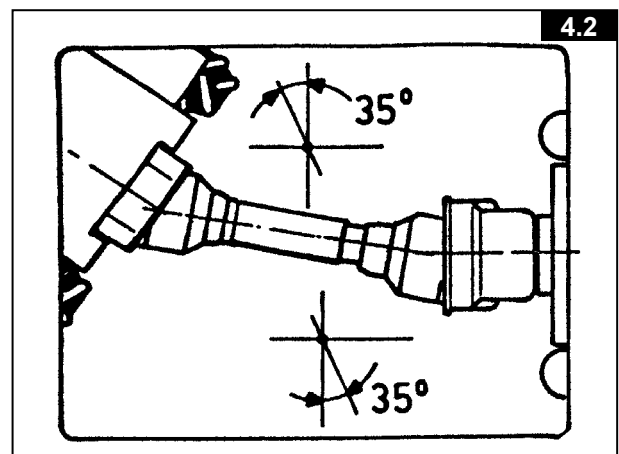

- 34-**Do not engage the power takeoff when the engine is not running.
- 35-**Always disengage the power takeoff when the cardan shaft is at too wide an angle (it should never be more than 35° as shown in fig. 4.2) and when it is not in use.
- 36-**Only clean and grease the Cardan shaft when the power takeoff is disengaged, the engine is off, the parking brake is applied and the ignition key is removed.
- 37-**On disconnecting the Cardan shaft, replace the protective hood on the power takeoff shaft.
- 38-**Prolonged use of the machine can cause the drive boxes to become hot. To avoid any risk of getting burnt, avoid touching these areas both during use and some time afterwards.
- 39-**Periodically check screws and nuts for tightness and grip. Tighten if necessary.
- 40-**When carrying out maintenance work or replacing the blades, raise the machine and rest on adequate supports.
- 41-**Use the quantities of grease and oil advised.
- 42-**Spare parts must meet the requirements as defined by the manufacturer. Use only original spare parts.
- 43-**Safety decals must always be clearly visible. They must be kept clean and replaced if they become too illegible (they can be ordered from the agent if necessary).
- 44-**The instruction booklet must be available for the lifetime of the machine.

## SECTION 5 PRODUCT IDENTIFICATION

### 5.1 TRACTOR REQUIREMENTS

Power takeoff speed (PTO)	<b>revs/min</b>	540
Max hydraulic pressure	<b>bar</b>	160
Minimum power required	(see 5.2)	
Simple distributor	<b>n°</b>	1

### 5.2 MACHINE TECHNICAL DATA

Type of machine		DM/6 S	DM/7 S	DM/8 S
Number of disks	<b>n°</b>	6	7	8
Number of knives per disk	<b>n°</b>	2	2	2
Working width	<b>m (inch)</b>	2.45 (96)	2.85 (112)	3.23 (127)
Gear ratio (PTO-disks)		2,73	2,73	2,73
Peripheral knife speed (PTO 540 revs/min)	<b>m/s (ft/s)</b>	81 (266)	81 (266)	81 (266)
Minimum power required	<b>kW (HP)</b>	34 (46)	39 (52)	41 (56)
Weight	<b>kg (Lb)</b>	560 (1235)	590 (1300)	635 (1400)

### 5.3 MACHINE IDENTIFICATION DATA

The machine is identified by means of the following technical data:

- Type of machine
- Registration number
- Year of manufacture
- Weight

stamped on the rating plate fastened to the frame of the machine. This data should be mentioned when requesting any replacements or information.



## SECTION 6 ASSEMBLY

### 6.1 TECHNICAL NOTES

We will provide a few examples to make it easier to choose which of the various accessories to use for each step of assembly. An approximate equivalent of the metric measurements is given in inches.

#### 6.1.1 PINS AND SCREWS (fig. 6.1)

Example: a pin with a 25 mm (1") diameter and a screw with an M 16 (5/8") diameter, both 50 mm (2") long, will be listed as:  
 D 25 x 50 (D 1" x 2") and M 16 x 50 (D 5/8" x 2").

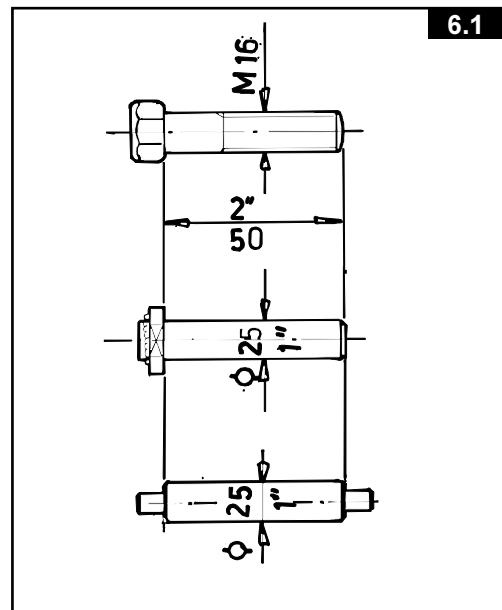

#### 6.1.2 SHIMS, SPACERS, BUSHINGS AND WASHERS (fig. 6.2)

Example: a shim, spacer, bushing or washer with an inside diameter of 25 mm (1"), outside diameter of 50 mm (2") and thickness or length of 13 mm (1/2") will be listed as:  
 D 25 - 50 x 13 (D 1" - 2" x 1/2").

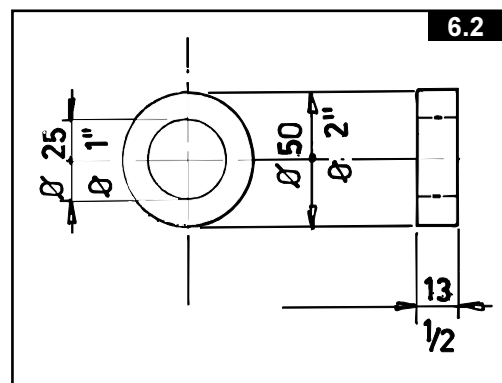

#### 6.1.3 NUTS, GREASE NIPPLES (fig. 6.3)

Example: a nut or grease nipple having a thread of M 8 (5/16") will be listed as:  
 M 8 (5/16")

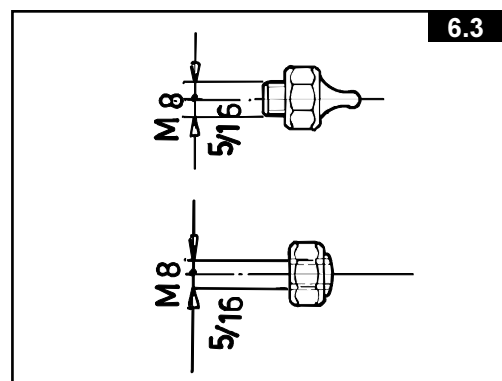



## 6.2 INSTRUCTIONS ON HOW TO ASSEMBLE

In fig. 6.4 is shown the packaging of the machine in crate. To put the machine as in fig. 6.5, using a forklift truck, crane or other suitable equipment of sufficient capacity attach, the machine in holes 1 and lift the machine pivoting in pin 5 until position in fig. 6.5 is reached.

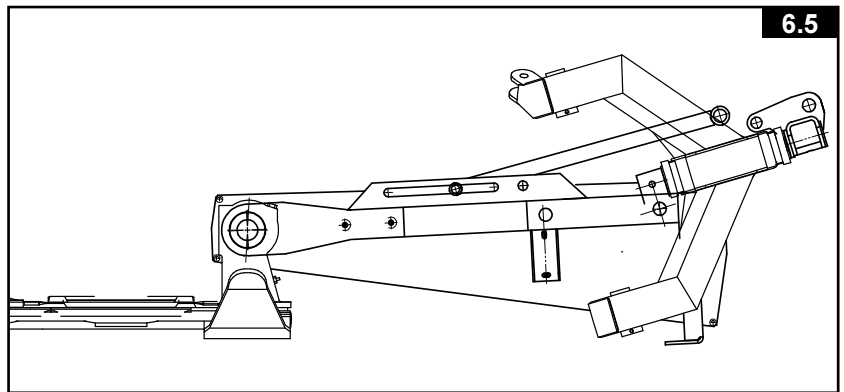
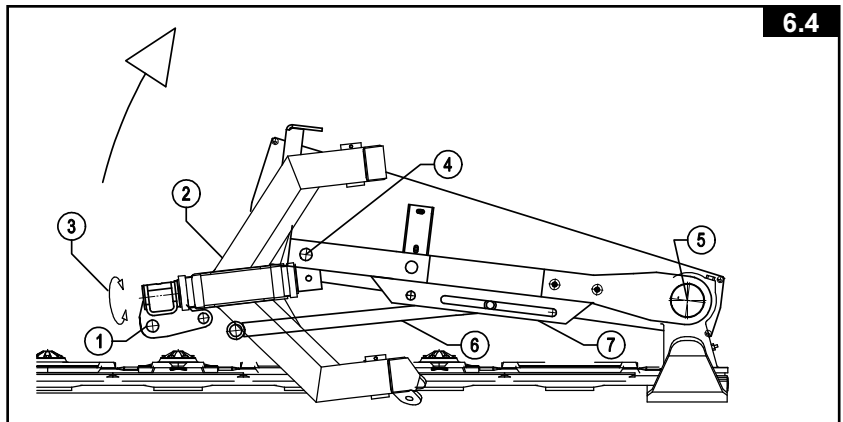

**Be careful: the frame 2 is very unstable. Frame 2 is pivoting in axle 3 and in pin 4.**

**Pay attention to tie rod 6 sliding on long hole 7.**

---

6.2.1 see pict. 6.6



Refer to fig. 6.6 and carry out the following steps in the order indicated:

- 1) Use pin 5 ( $\varnothing 35 \times 244 - \varnothing 1\frac{3}{8} \times 9\frac{19}{32}$ ) to mount tie rod 1 into the support 20 and fasten with two spring pin ( $\varnothing 8 \times 50 - \varnothing 5/16 \times 2$ ).
- 2) Mount rubber 24 to tie rod 1.
- 3) Mount lock spring 3 on tie rod 1 with screw M8x55 ( $5/16 \times 2\frac{5}{32}$ ), washer  $\varnothing 9$  ( $\varnothing 11/32$ ) and nut M8.
- 4) Mount four grease-nipple 9 M6.

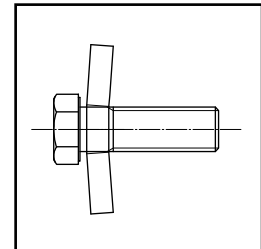
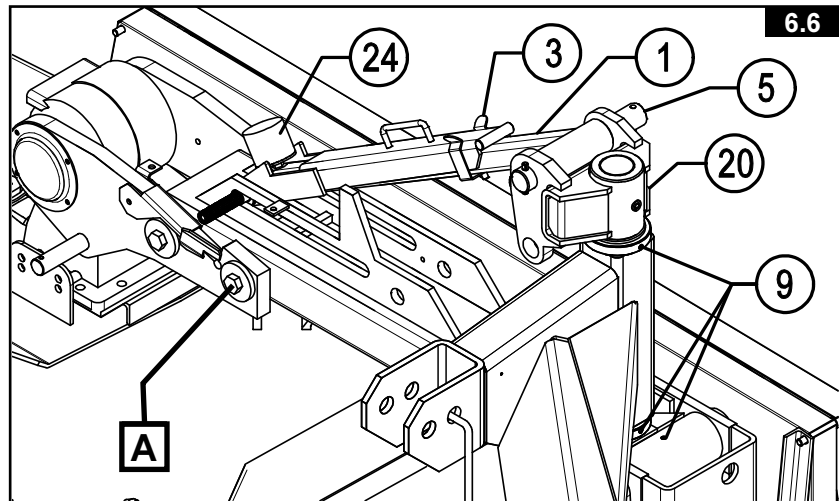

ATTENTION!! The four screws A (M16x50 10.9) at both side of the machine, are mounted with 300 Nm torque and Loctite. The cup washers are mounted as in figure.

6.2.2 see pict. 6.7



Refer to fig. 6.7 and carry out the following steps in the order indicated:

- 1) Mount safety bar 1 with rubber spring 3 on side as in figure, with two pins 2 ( $\varnothing 22 \times 117 - \varnothing 55/64 \times 4\frac{19}{32}$ ) and three spacer 4-5 ( $\varnothing 23 \times \varnothing 30 \times 10 - \varnothing 1\frac{11}{64} \times \varnothing 57/64 \times 22/64$ ) into the supports as in figure. and fasten with spring pin ( $\varnothing 6 \times 35 - \varnothing 15/64 \times 1\frac{3}{8}$ ) and washers ( $\varnothing 23 - \varnothing 57/64$ ).The spacer 5 has to be mounted on one side as in figure.

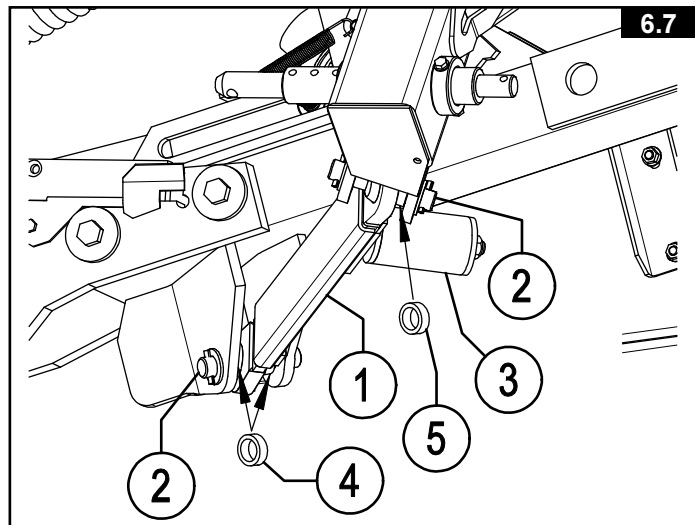

**6.2.3 see pict. 6.8**  
**Mount internal conveyor disc**

The conveyor disk 5 (see fig. 6.9) are splined to a shaft and have to be positioned so that the main axle is at right angles with those next to it (see fig. 6.8).

Cupped washer 1 in figure must be mounted with its concavity facing downwards. The self-locking nut 2 must be tightened with a dynamometric spanner set at 320 Nm torque.

The screws 3 (n°6 M10 x 20 flanged) must be tightened with a dynamometric spanner set at 70-80 Nm torque. Then mount plug 4.

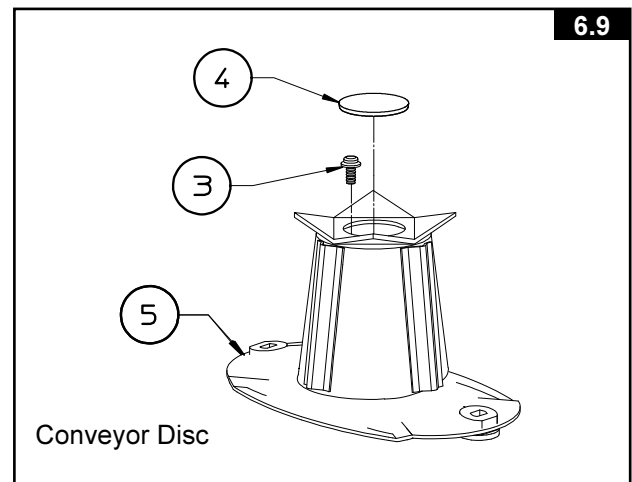
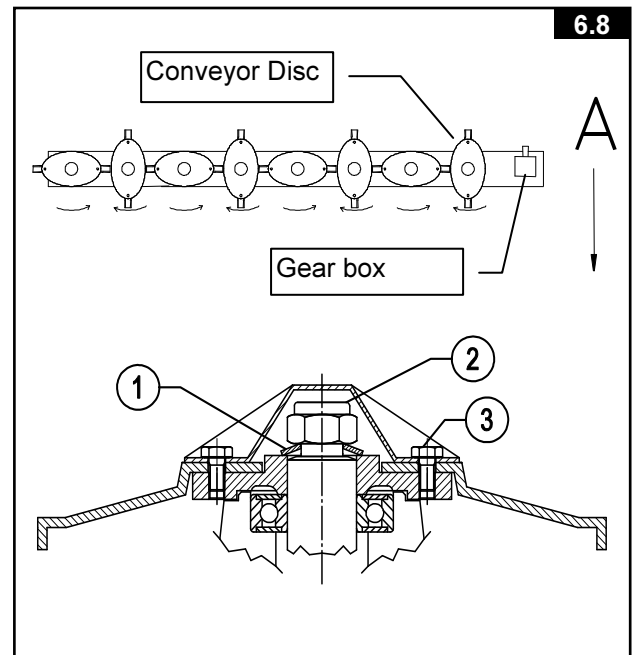

6.2.4 see pict. 6.10



Refer to fig. 6.10 and carry out the following steps in the order indicated:

- 1) Mount protection canvas support 4 to the gearbox (align it vertically) with four screws 1, growers 2 and washer 3:  
 screws M12 x 40 (15/32 x 1"9/16) for 6 discs model (100 Nm torque)  
 screws M14 x 40 (35/64 x 1"9/16) for 7 discs model (110 Nm torque)  
 using loctite or similar.

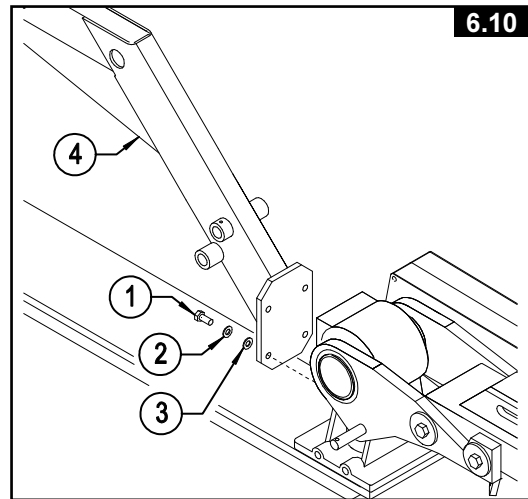

6.2.5 see pict. 6.11

- 1) Mount hook 1 as in figure with pin 2 and fasten with two spring pin ( $\varnothing 6 \times 40 - \varnothing 15/64 \times 1"36/64$ ) and two washers ( $\varnothing 26 - \varnothing 1"$ ).
- 2) Mount spring 3 as in figure.
- 3) Mount the lever 5 as in figure with screw 6 (M8x45 – 5/16" x 1"49/64), and locknut without tighten fully.
- 4) Mount the threaded rod 7 and ball joint on point 9 with normal nut M8. The distance A should be ~504mm (19" 53/64)
- 5) Mount the ball joint on point 8 of lever 5 with selflocking-nut M8 as in figure.
- 6) Fasten rod 7 on point 10 with special hexagon pin and one split pin ( $\varnothing 3 \times 30 - \varnothing 7/64 \times 1"11/64$ ).
- 7) Mount rope in hole 4 with a node.

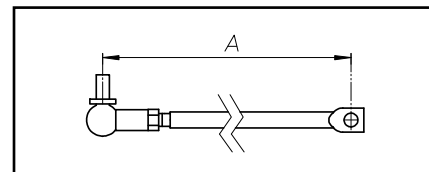
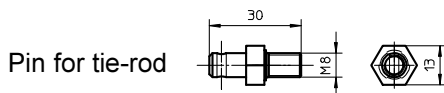
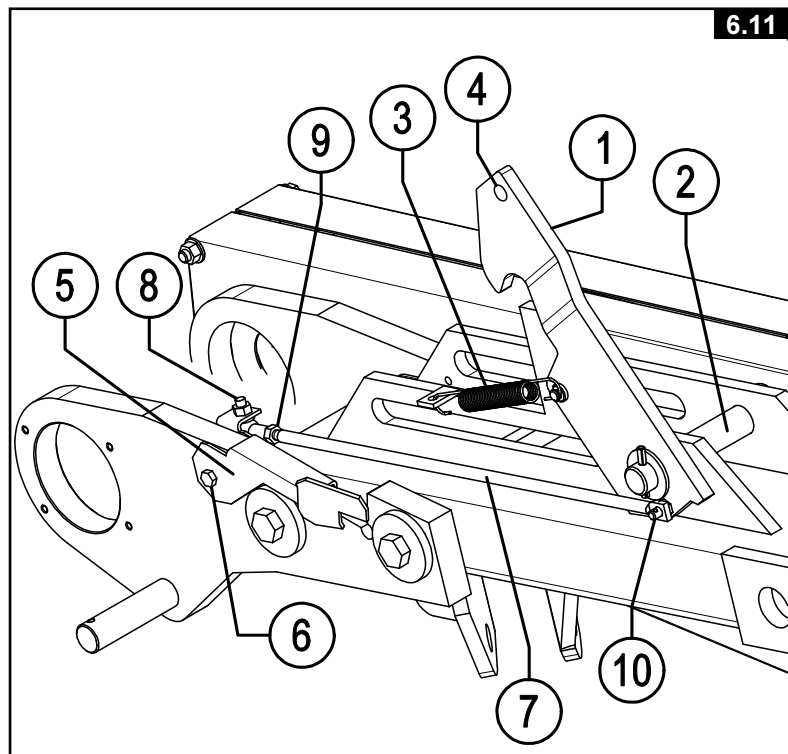

**6.2.6 see pict. 6.12**

Refer to fig. 6.12 and carry out the following steps in the order indicated:

- 1) Mount hay plate 1 to the cutter bar with screws item 2 (M12x35 – 1/2" x 1"3/8) and 3 in picture (M10x35 – 3/8" x 1"3/8) and washers (ø 10 – 25/64).
- 2) Mount support 5 to the canvas support 6 with four screws item 4 in picture M12 x 25 (15/32 x 1") and growers (ø 13 – 1/2") with 80 Nm torque.
- 3) Mount support 5 in point 7 with screw M14 x 50 (35/64 x 2") and two nuts M14 counterlocked (180 Nm torque).

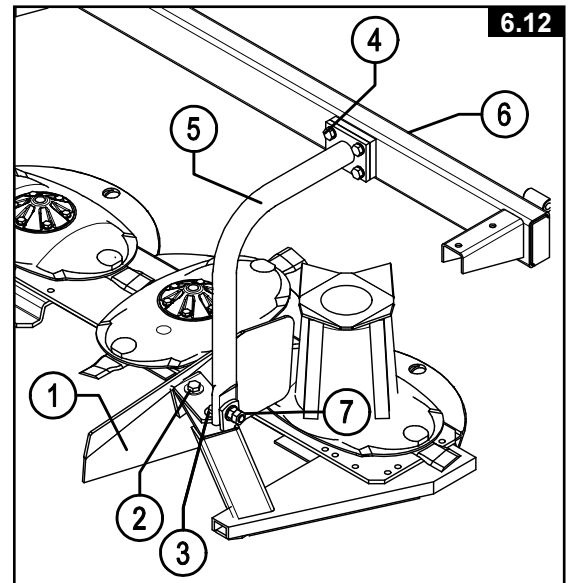
**6.2.7 see pict. 6.13**

Refer to fig. 6.13 and carry out the following steps in the order indicated:

- 1) Mount spring 38 as in figure on pin 28 and fasten with one spring pin 39 (ø8x50 - ø5/16 x 2") and washer 30 (ø 25 - ø 1"). If necessary, unscrew tie-rod 37 until to fit pin 5. Remember to readjust spring tension (see 8.4).
- 2) Mount the threaded rod 37 of the spring 38 on pin 5 with spacer 36 (ø35-ø42x20 - ø1"3/8-ø1"41/64x 25/32) and washer 40 (ø35 - ø1"3/8) and fasten with one spring pin 39 (ø8x50 - ø5/16x 2").

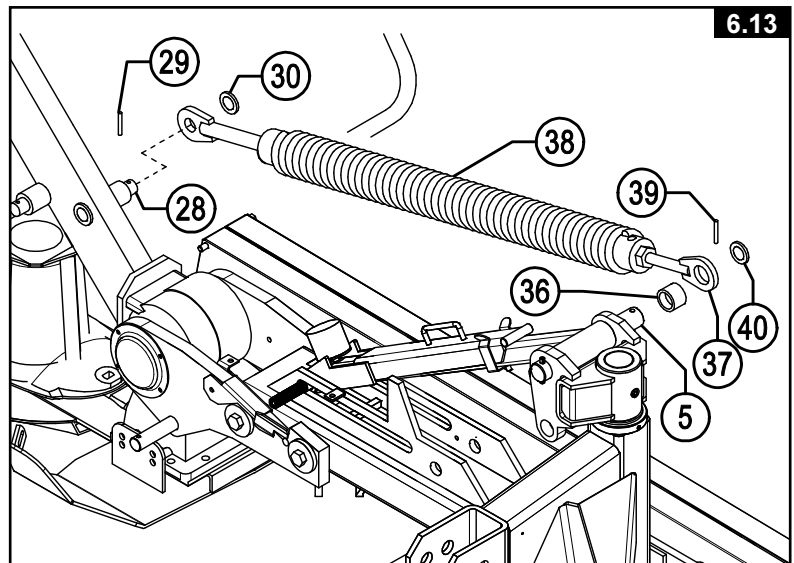

## 6.2.8 see pict. 6.14

- 1) Mount lift lever 1 as in figure on pin 2 and fasten with one spring pin ( $\varnothing 6 \times 45 - \varnothing 15/64 \times 1''49/64$ ) and washer ( $\varnothing 26 - \varnothing 1''$ ).
- 2) Mount lift lever 3 as in figure on pin 4 and fasten with one spring pin ( $\varnothing 6 \times 45 - \varnothing 15/64 \times 1''49/64$ ) and bush with hole ( $\varnothing 25 - \varnothing 40 \times 21 - \varnothing 1'' - \varnothing 1''9/16 \times 13/16$ ).
- 3) Mount lift cylinder 6 as in figure (**the hose attach must be on the down side of the cylinder**) with:
  - pin 5 ( $\varnothing 30 \times 85 - \varnothing 1''11/64 \times 3''9/64$ ) with two spring pin ( $\varnothing 8 \times 50 - \varnothing 5/16 \times 2''$ ) and two washers ( $\varnothing 31 - \varnothing 1''11/64$ );
  - pin 7 ( $\varnothing 25 \times 148 - \varnothing 1'' \times 5''13/16$ ) with two spring pin ( $\varnothing 6 \times 45 - \varnothing 15/64 \times 1''49/64$ ) and two washers ( $\varnothing 26 - \varnothing 1''$ ), position cylinder 8 and lever 3 as fig. 6.14

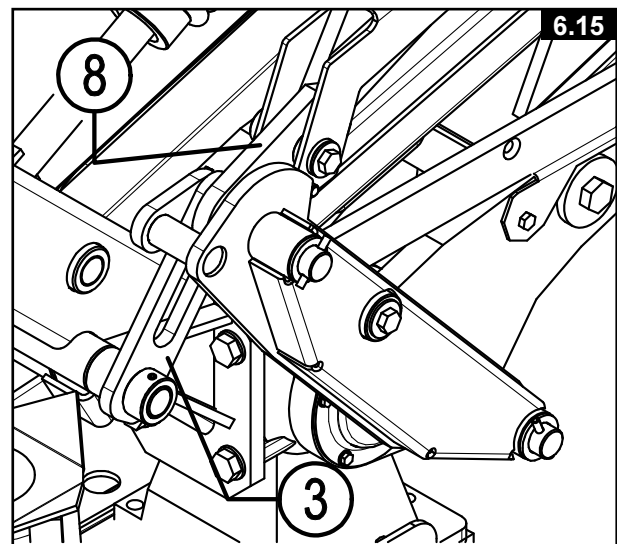
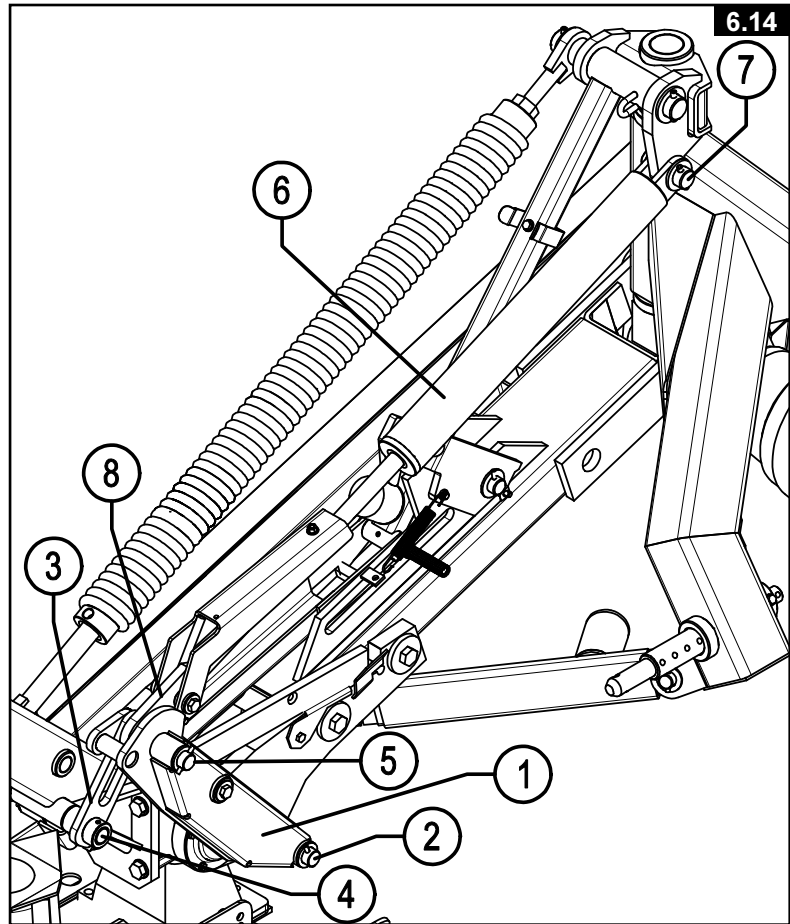

**6.2.9 see pict. 6.16**

Refer to fig. 6.16 and carry out the following steps in the order indicated:

Mount conveyor sheet 4 with:

- 1) point 9: screw (M 8 x 25 – 5/16" x 1"), two large washers and nut
- 2) point 8: screw (M 10 x 25 –  $\varnothing$  25/64" x 1"), washer and nut
- 3) point 11: on the rear view of the machine with screw (M 10 x 25 –  $\varnothing$  25/64" x 1"), washer and nut.

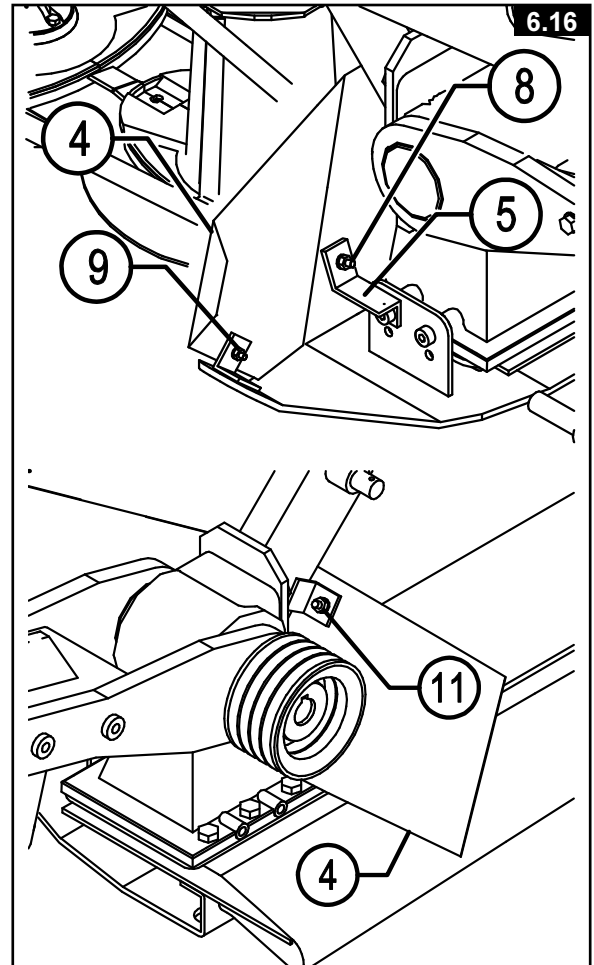

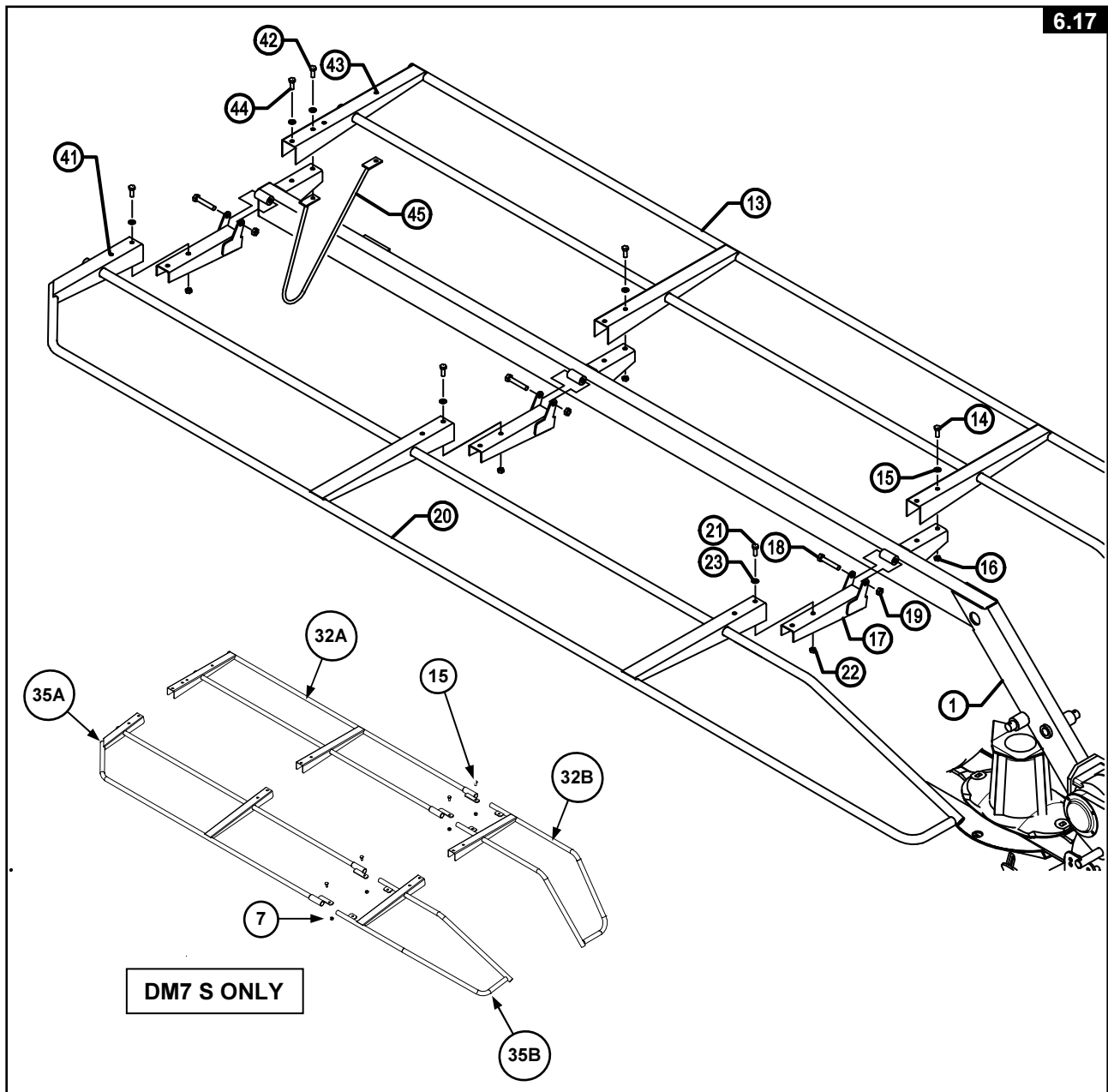

### 6.2.10 see pict. 6.17

Refer to fig. 6.17 and carry out the following steps in the order indicated:

- 1) Mount rear protection 13 on support canvas 1 as shown with five screw 14 (M10 x 20 – 25/64 x 25/32) and nut 16 (M10 – 25/64) and washer 15; use screw 42 (M10 x 25 – 25/64 x 1") to mount vertical protection 45. **Do not use hole 43 at this time.**
- 2) Mount the three pivoting supports 17 on support canvas 1 as shown with three screws 18 (M12 x 75 – 15/32 x 2"15/16) and self-locking nuts 19 (M12 – 15/32)

**Do not fully tighten the screws 18 to let pivoting the front protection.**

- 3) **[DM7S only]** - Mount together protection 35A-B and protection 32A-B with four screw 21 (M10 x 25 – 1 x 25/32) and nut 7.
- 4) Mount front protection 20 on pivoting supports 17 as shown with five screw 21 (M10 x 20 – 25/64 x 25/32) and nut 22 (M10 – 25/64) and washer 23. **Do not use hole 41 at this time.**
- 5) Mount plugs for pipe ( $\varnothing$  27 x 2.5 –  $\varnothing$  1" 1/16 x 3/32").



**6.2.11 see pict. 6.18**

Refer to fig. 6.18 and carry out the following steps in the order indicated:

- 1) Mount protection canvas with the opening for cylinder and spring bar in right position. Fasten all the belt of the canvas.
- 2) Mount plugs ( $\varnothing$  33.7 x 3 – 1" 5/16 x 7/64") for pipe 1 and 2
- 3) Make three holes 10 on protection canvas as shown for screws 5 (M 10 x 25 – 25/64" x 1") to assembly support 1 and 2, and fasten with washer 7 and nut 6.
- 4) Use screws 3 (M 10 x 75 – 25/64" x 2" 15/16) and self-locking nuts 4 to mount support 1 and 2, but not fully tighten to make them pivoting.
- 5) Mount pivoting spring 8 on pins 9.

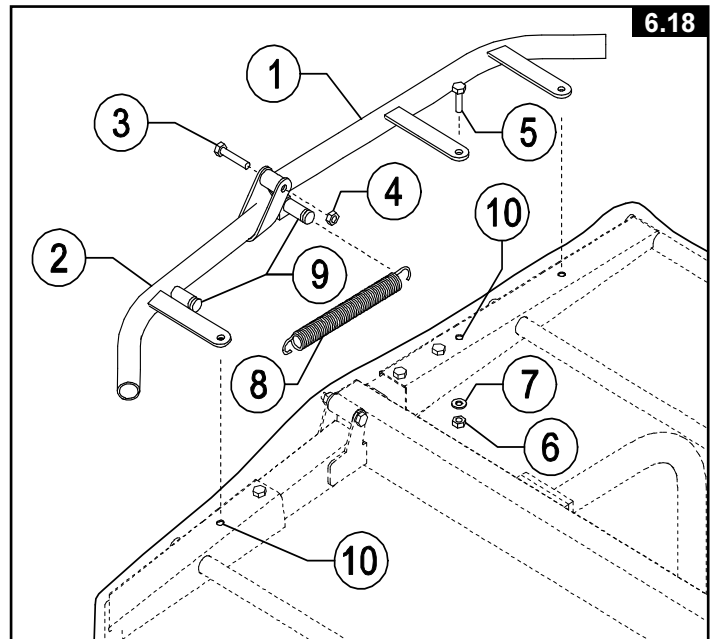
**6.2.12 see pict. 6.19**

Refer to fig. 6.19 and carry out the following steps in the order indicated:

- 1) Use two screws 8 M6 x 16 (D 15/64" x 5/8") and large washers 6 to assemble casing 7.
- 2) Insert the two hoist pins 13 into their respective slots and use screws 22 M8x80 (5/16" x 3" 9/64), nuts 21 to fasten into the position which best suits the dimensions of the tractor.
- 3) Insert clamp 12 of hoist chain 11 on one of the hoist pins 13 and fasten with washer 14 ( $\varnothing$  25 –  $\varnothing$  1") and spring pin 15 ( $\varnothing$  8 x 50 –  $\varnothing$  5/16" x 1" 61/64).
- 4) Insert cardan shaft hook 24 in one hole of 3<sup>rd</sup> point and use clip 20 to lock it when machine is operating.
- 5) Pin 25 is used for the 3<sup>rd</sup> point tractor attach.
- 6) Insert hydraulic hose 1 in the open ring 2.

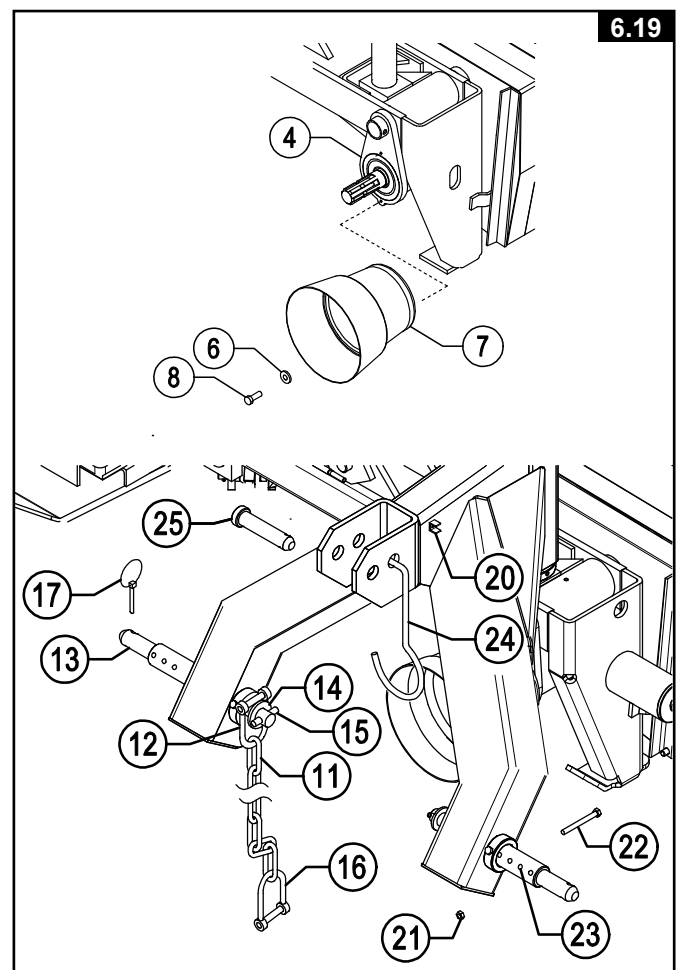
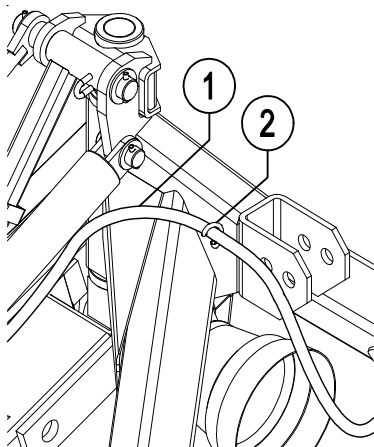

## SECTION 7 INSTRUCTIONS FOR INSTALLATION AND USE

### 7.1 HOW TO ADAPT TO THE TRACTOR

The machine can be adapted to tractors with various gauges by placing the two hoist arms as shown in figure 7.1, so that distance A is about 5 cm (2 inches) when the machine is in the work position.

In order to obtain the various positions in fig. 7.1, slide the pins 13 (fig.7.2) in the respective slots and fasten into position with screws 22 and nut 21 (fig. 7.2) in one of the adjustment holes 23 on the pins.

- 1) If necessary, move the vertical movement adjuster tie rod on the hoist arms until both ball-and-socket joints are at the same height above ground.
- 2) Fasten the two tractor hoist arms into pins 13 and lock with pegs 24 (fig. 7.2).
- 3) Fasten the third point tractor 1 (fig. 7.3) and adjust it so that axle E is vertical.
- 4) Rise the machine with the tractor's hydraulic lift, put up the stand A (Fig. 7.4) until it hooks onto the lock spring B.

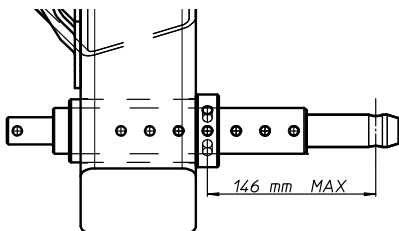
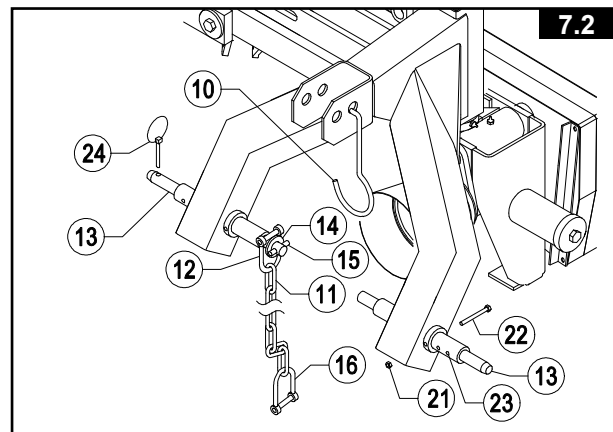
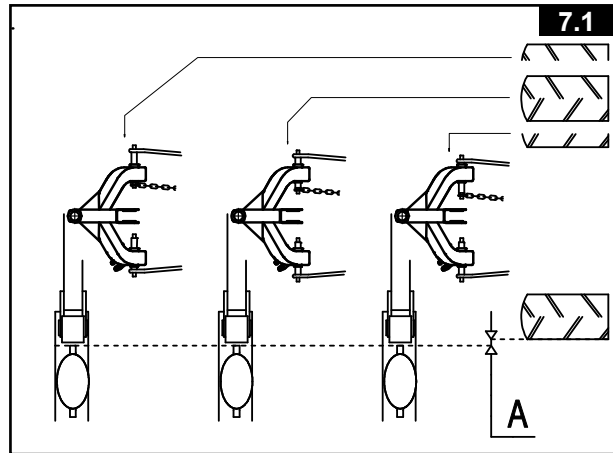

**WARNING !!!**



**When working and during transport, the stand A must be locked in the lock spring B (Fig. 7.4).**

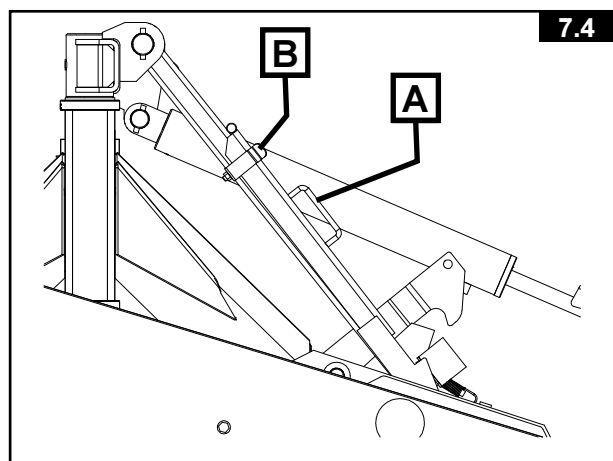
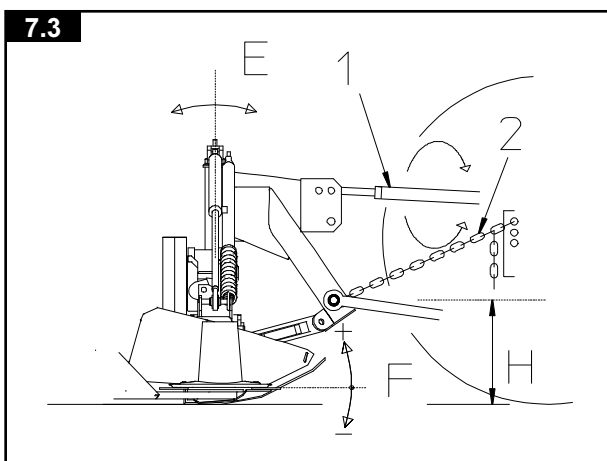

## 7.2 Adjustment of the height of the frame above the ground

**For tractors equipped with a hydraulic lift limiter with controlled position:**

- 1) On flat ground, lower the tractor's hydraulic lift until bar A (Fig. 7.5) hooks into place. Bar A must have a functional play "X" of about 3 mm (0.15 inches) as shown in Fig. 7.5.
- 2) After having adjusted the height of the frame, set the position of the lift control from the driver's seat of the tractor. In this case it is not necessary to use the limiting chain 2 (Fig. 7.6) supplied with the machine.

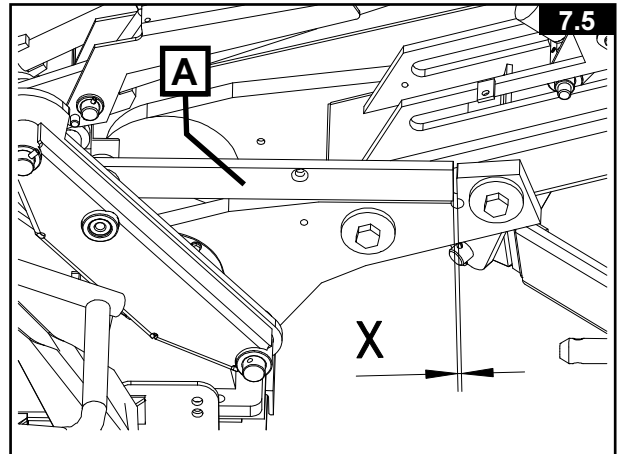

**For tractors not equipped with a hydraulic lift limiter with controlled position:**

- 1) Fasten in place the limiting chain 2 in Fig. 7.6 supplied with the machine with the hook (16) in Fig. 7.2 to one of the free holes in the bracket of the tractor third point.
- 2) Lower the machine into the work position until the bar A (Fig. 7.5) enters in its place and the limiting chain 2 (Fig. 7.6) is taut. Bar A (Fig. 7.5) must have a functional play "X" of about 3 mm (0.15 inches). The height H from the ground is correct when there is:
  - Mower bar on the ground.
  - Distance "X" of about 3 mm (0.15 inches).
  - Limiting chain 2 in Fig. 7.6 taut.

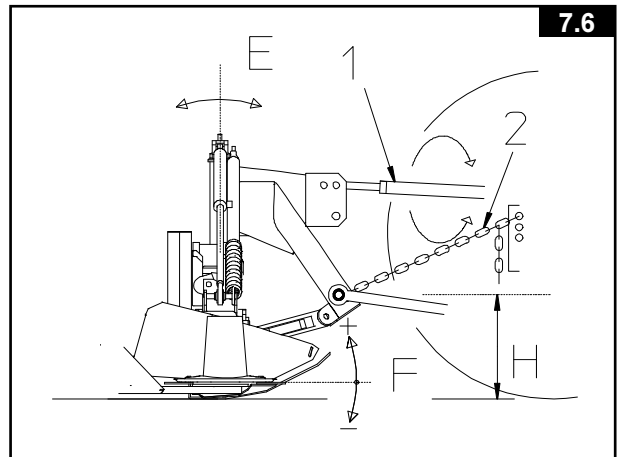

### 7.3 HOW TO ADAPT THE CARDAN SHAFT

In order to make sure that the cardan shaft is the right length compared with the tractor power takeoff (with the machine already attached to the tractor), proceed as follows(see pict. 7.2):

- 1) Remove the two cardan joint axle shafts and insert them separately on the two power take-offs (tractor and mowing machine) with the clutch on the side of the mowing machine.
- 2) Place the two axle shafts one alongside the other.
- 3) Check that when the cardan shaft is stretched to its minimum length (repeatedly raise and lower the machine to find this position), the tubes do not touch the bottom, so that there is always a minimum clearance B of 20 mm (0.79 inches).
- 4) If necessary, reduce the two axle shafts as well as the two axle shaft protections by the same amount (keeping the above-mentioned conditions), and take care to clean and lubricate them before starting work.

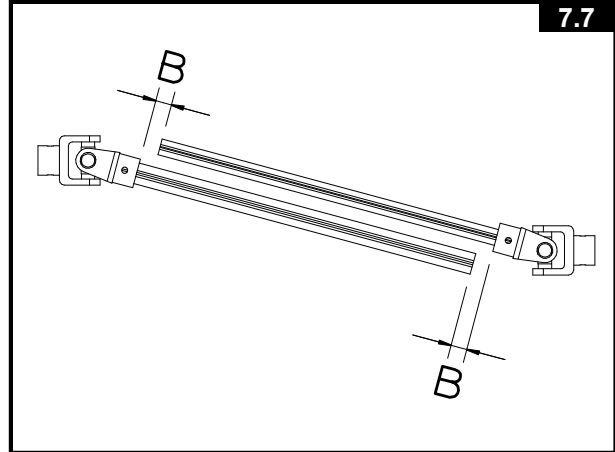

**⚠ ATTENTION !!! ⚠**

**When the cardan shaft is stretched to its maximum length (with the safety device released), the cardan tubes must remain inserted at least 10 cm (4 inches).**

Use the relevant chains to fasten the outer cardan shaft protection

**⚠ DANGER !!! ⚠**

**It is your responsibility to read and comply with this documentation. If information given in this manual should conflict with that given in the Cardan shaft manual, you should follow the instructions given by the Cardan shaft manufacturer.**

## 7.4 PUTTING IN THE TRANSPORT POSITION



**DANGER !!!**



**Make sure that no person or object is standing within the turnover range of the disk carrier bar.**

### IMPORTANT

**Before transport the machine on public roads, the user must always make sure that it complies with the highway code.**

To put the machine into position for transport on public roads or from one field to another, do the following:

- 1) With the machine in the work position, detach the tractor power takeoff and wait until all moving components have come to a full stop.
- 2) Flip back the front deflector A (Fig. 7.8).
- 3) Pull the cord of hook C to free the lifting brace (D) (Fig. 7.9). If the lifting brace (D) is not free in his socket, lower the tractor's hydraulic lift until the lifting brace (D) is free and then pull the cord of hook C.
- 4) Raise completely the machine with the tractor hydraulic lift.
- 5) Slowly raise the mower bar vertically actuating the machine's hydraulic cylinder. Release the tension of the cord of hook C (Fig. 7.9) while raising the mower bar vertically. This will hook automatically with the locking hook C (Fig. 7.9).

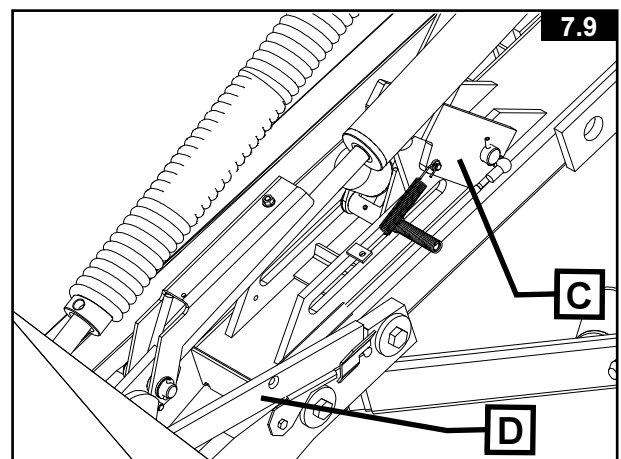
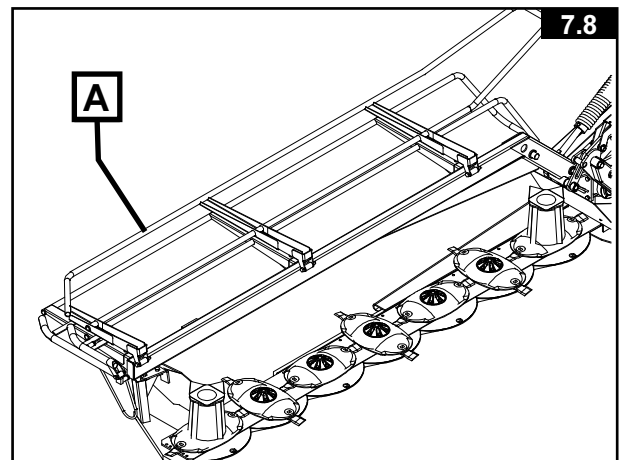

**WARNING !!!**



**Pull the cord of hook C (Fig. 7.9) every time you want to raise the mower bar into the vertical position. While raising it vertically, release the tension on the cord.**

**THE TOTAL TRANSPORT HEIGHT OF THE MACHINE MEASURED FROM THE GROUND MUST NOT EXCEED THE MAXIMUM HEIGHT AUTHORIZED BY THE HIGHWAY CODE.**

## 7.5 PUTTING IN THE WORK POSITION



**BEFORE PUTTING IN THE WORK POSITION, SEND ALL PEOPLE AWAY FROM THE MOWER BAR PIVOTING ZONE.**

With the machine in the transport position, proceed as follows:

- 1) Put the hydraulic cylinder under pressure to lighten the locking hook A (Fig. 7.10).
- 2) Pull the cord of hook A to release the lock.
- 3) Lower the mower bar into the work position using the machine's hydraulic cylinder.
- 4) Flip the front deflector C (Fig. 7.11) forward into the work position as shown in figure.
- 5) Check the height of the frame from the ground. The lifting brace D (Fig. 7.12) must be in its place and have a functional play "X" of about 3 mm (0.15 inches).

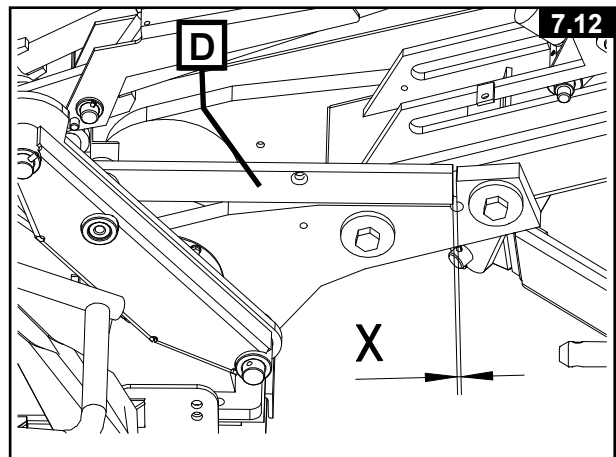
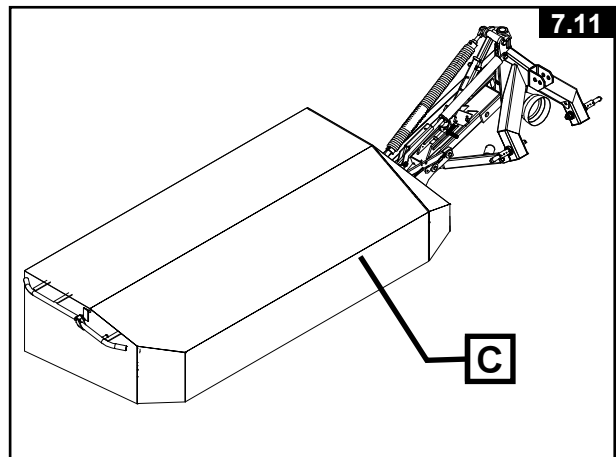
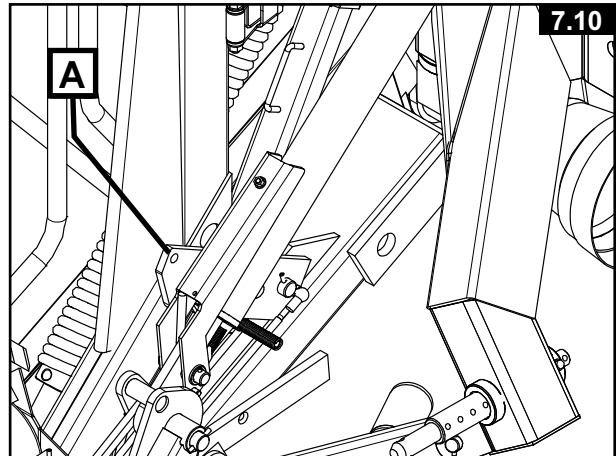

## 7.6 USE OF THE DISC MOWER



**DANGER !!!**



**MAKE SURE THAT THE PROTECTIVE COVER IS SECURELY IN PLACE ALL AROUND THE MOWER BAR HAZARD.**

The protective cover avoids the throwing out of plant residues and foreign objects.

Before putting the mower bar into the forage, connect the tractor power takeoff and accelerate gradually up to 540 RPM.

The forward speed must be adapted to the working conditions.

When working, the simple effect hydraulic distributor must always be in the floating position to allow good adaptability to the unevenness of the ground.

For lifting operations at the head of the field (Fig. 7.14), the mower bar maneuver is done with the machine's hydraulic cylinder.

The lifting kinematics are conceived to free the group from the ground while the mower bar is raised. To do this, actuate the hydraulic cylinder until the locking hook A of the piston reaches the end of stroke (Fig. 7.13).

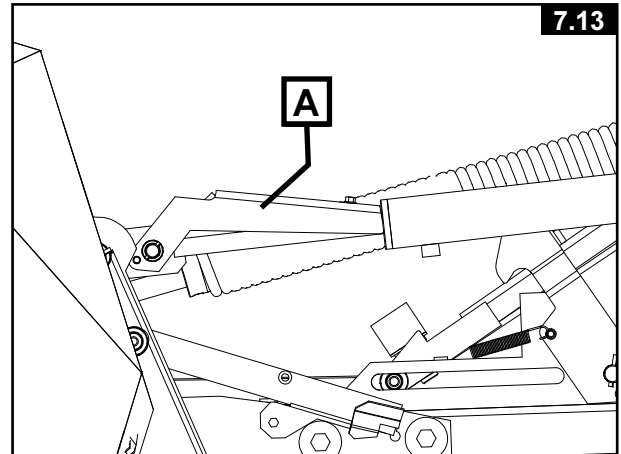

**7.13**

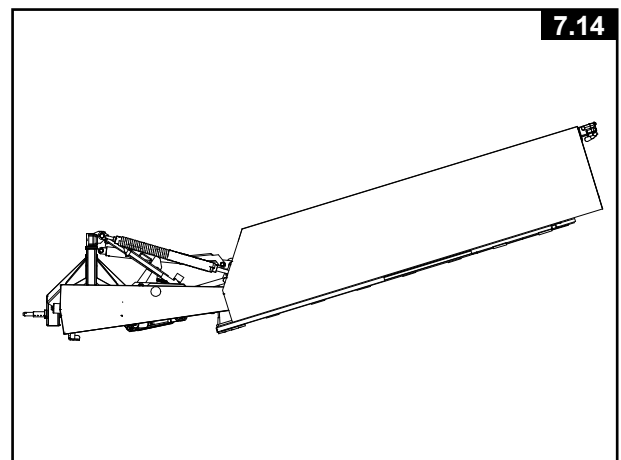

**7.14**



**WARNING !!!**



**Every time machine's hydraulic cylinder is actuated during working position, the lifting brace D (Fig. 7.12) must be in its socket, otherwise damaging may occur.**



**DANGER !!!**



**CAUTION. NEVER MOW ON STONY OR ROCKY SOILS.**



**WARNING !!!**



**WHILE WORKING THE PROTECTIVE COVER MUST ALWAYS BE IN PLACE WITH THE FRONT PART OF THE PROTECTION LOWERED. NEVER LEAN ON OR CLIMB ON THE PROTECTIVE COVER.**

## 7.7 HOW TO DISCONNECT THE MACHINE



During operations to disconnect the machine, be careful not to lower the mower bar below the horizontal line (Fig. 7.17).

- 1) Using the hydraulic cylinder, lower the disc mower bar into the horizontal position (Fig. 7.17).
- 2) Unlock component A (Fig. 7.15) and turn it over downward against plate B on the drop box (Fig. 7.16). For this, make sure that the upper part of the drop box is free of foreign objects.
- 3) Actuate the tractor hydraulic cylinder to lower the machine to the ground.
- 4) Disconnect the third point and disconnect the hydraulic hose.
- 5) Then disconnect the drawbars and the cardan driveshaft.

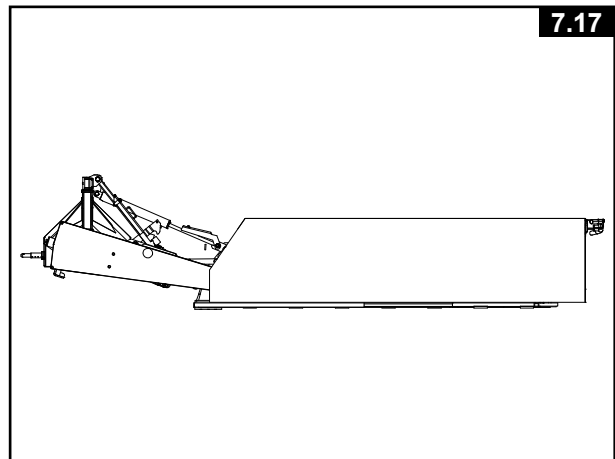
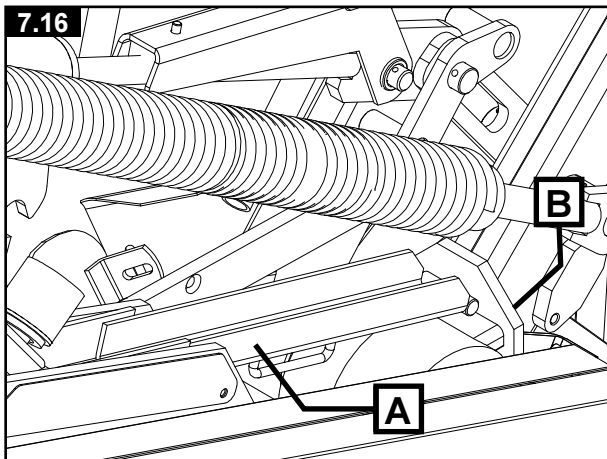
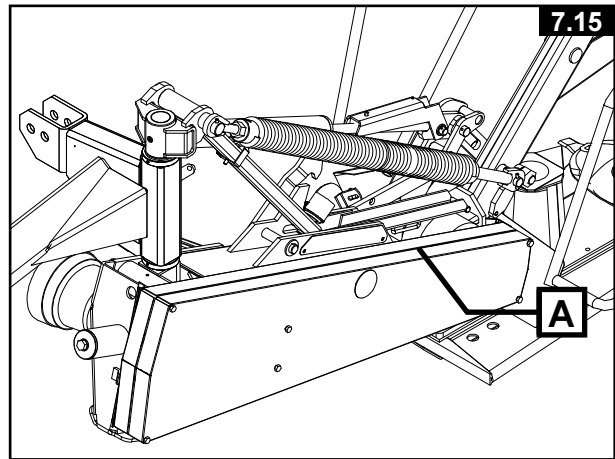

**FOR YOUR SAFETY: ALWAYS DISCONNECT THE MACHINE WITH THE MOWER BAR IN THE HORIZONTAL POSITION.**



## SECTION 8 ADJUSTMENTS AND SET-UP

### 8.1 BELT TENSION

Belt tension must be checked regularly particularly during the first few hours of use. In order to adjust tension proceed as follows (see pict. 8.1):

- 1) In order to have the right belt tension, you have to tighten screw A till the spacing pipe C is in contact with upright D and washer B, then you have to tighten screw A for other 2 complete turns.
- 2) Finally check that tension is correct. Distance, visible through opening on rear side of belt cover, is about 20 mm (0.8 inches) when pressure is applied to the belt.

Note : You have to tighten the screw A for the 2 final turns, just for the first assembling and the following replacements of belts.

If a belt has to be replaced, all belts should be replaced at the same time.  
The belts must be loosened at the end of the season.

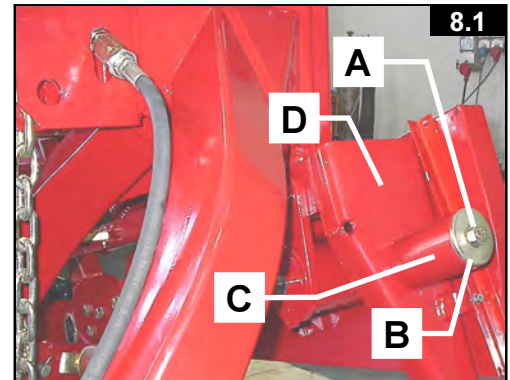

### 8.2 CUTTING HEIGHT

The cutting height can be adjusted by using turn-buckle 1 on the third tractor point to vary the tilt of the knives compared to the ground (distance F in fig. 8.2).

Cutting height may vary within the range of 16/60 mm (0.63/2.36 inches) even though uneven land may influence these values.

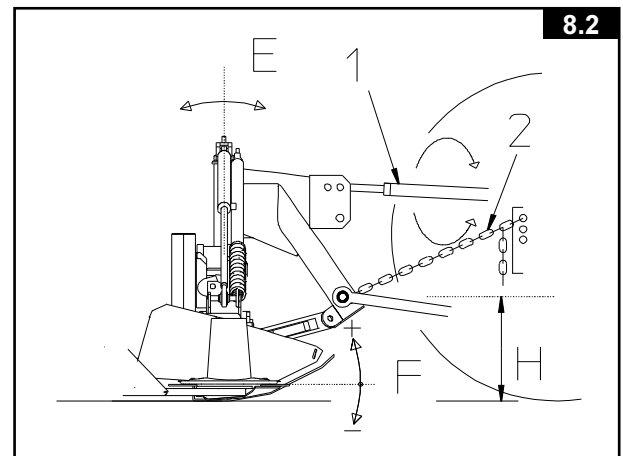

### 8.3 HYDRAULIC FLOW ADJUSTER

The hydraulic flow adjuster 1 in fig. 8.3 (item 4 rapid-coupling and item 3 hydraulic hose) is used to move down to the ground the cutting bar slowly to prevent it from damage.

To set hydraulic flow adjuster turn nut 1:

The standard adjustments is two complete turns from max slow position.

When setting operation is ended lock nut 1 with counter-nut 2.

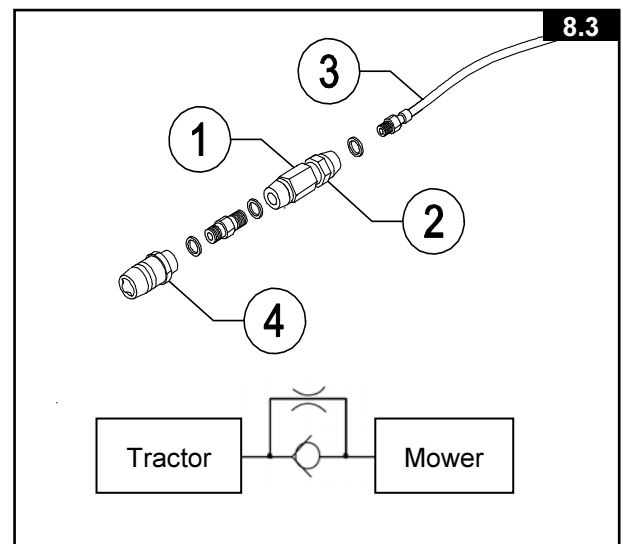

**Pay attention to hydraulic flow adjustment: try to move up and down the cutting bar during setting operation to check the right adjustment.**

**The hydraulic flow adjuster works in only one direction so always check the right assembly as in figure.**

## 8.4 SPRING TENSION

To adjust spring tension (fig. 8.4):

- 1) Lift the disk carrier bar until spring is not tensioned.
- 2) Loosen the nut A and turn the spring B.
- 3) When adjust is completed, tighten the nut A.

The dimension C is (standard adjustment):

100 mm (4") for 7-8 discs model

130 mm (4") for 6 discs model

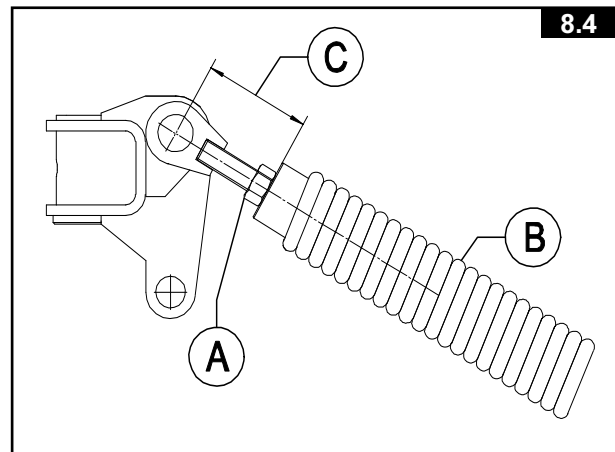

**DANGER !!!**



**The dimension C must be always lower than**

**130 mm ( 5" 7/32) for 7-8 discs model**

**150 mm ( 5" 57/64) for 6 discs model**

**for transport position**

## 8.5 SAFETY DEVICE

Safety device B (fig. 8.5) unhook when it receives blows that are too strong for the machine structure.

The dimension A is the length of the rubber spring of safety device when tensioned between the two washers; it is 95 mm (3" 47/64) for the standard adjustment.

When adjust the length of the spring, tighten the relevant screw very carefully until unhooking occurs at reasonable intervals only.



**DANGER !!!**



**The dimension A must be always higher than 85 mm (3" 11/32).**

**Danger of not unhooking when it receives blows that are too strong for the machine structure**

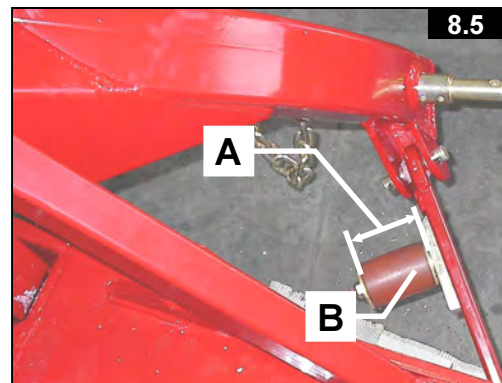

## SECTION 9 FAULTS: REASONS AND REMEDIES

### 9.1 **The disk carrier bar vibrates too much during work:**

the nylon bushings of the joints in question are over worn or completely worn out.

⇒ replace the bushings;

the pins and/or respective bushings/bearings of the joints in question are over worn.

⇒ replace the worn-out parts and lubricate regularly;

the outer conveyor is too slack

⇒ check that it is fastened correctly.

### 9.2 **The disk carrier bar does not adapt correctly to uneven ground:**

the height of the tractor coupling plate is not adjusted correctly

⇒ readjust as specified in point 7.1 (in particular check that both ball-and-socket joints are the same height above ground);

the machine joints resist free rotation

⇒ clean and lubricate the parts in question.

### 9.3 **The disk carrier bar is not raised parallel to the ground:**

the entire machine is leaning to one side

⇒ check that both hoist ball-and-socket joints are at the same height above ground;

Earth accumulates between two sliding blocks in the front part of the disk carrier bar:

### 9.4 **7.4 Earth accumulates between two sliding blocks in the front part of the disk carrier bar**

The ground is exceptionally wet;

the bar presses too hard on the ground

⇒ increase tension of the spring B fig. 8.4;

the disk carrier bar tilts too far forward

⇒ adjust the tilt of axle E fig. 8.2 by moving turnbuckle 1 on the third point.

### 9.5 **Safety device (fig. 8.5) often unhooks under impact:**

The rubber buffer B is worn out or is not adjusted correctly.

⇒ check the condition of the rubber buffer and if necessary, tighten the relevant screw very carefully (**danger of not unhooking when it receives blows that are too strong for the machine structure**) until unhooking occurs at reasonable intervals only.

### 9.6 **The stubble is too high or too sparse:**

The disk carrier bar does not tilt correctly (axle E in fig. 8.2)

⇒ use turnbuckle 1 on the third point to adjust the tilt.

### 9.7 **The stubble is not the same height all along the cutting width:**

the disk carrier bar tilts too much

⇒ reduce the tilt of the disk carrier bar (fig. 8.2);

the knives are over worn

⇒ replace the knives;

power takeoff speed is insufficient

⇒ increase power takeoff rotation speed up to, but not over, 540 revs/min;

forward movement speed is too fast

⇒ reduce tractor speed.

### 9.8 **The forage is pushed forward before being cut:**

the ventilating effect of the knives is too strong

⇒ reduce power takeoff rotation speed and increase tractor forward movement speed.

## SECTION 10 MAINTENANCE

### 10.1 HOW TO FASTEN CUTTING DEVICES

After they have been used the first time, the disks, knives and relevant parts to fasten them must be controlled regularly every 15-20 working hours. More frequent checks will have to be made if mowing is carried out on stoned ground and after impact with an obstacle.

The oval disks are splined to a shaft and have to be positioned so that the main axle is at right angles with those next to it (fig. 10.1).

The knives are fastened by means of a special self-tapping screw and an M12 nut (fig. 10.2); the nut must be tightened with a 16 kgm (160 Nm) torque.

Cupped washer 1 (fig. 10.3) must be mounted with its concavity facing downwards. The self-locking nut 2 must be tightened with a dynamometric spanner set at 32 kgm (320 Nm).

The six screws 3 must be tightened with a dynamometric spanner set at 70-80 Nm torque.

Pay attention to the direction of disk rotation. Worn knives can be replaced by carefully looking at fig. 10.1 (A is the work moving direction); the second cutter (if still in good condition) can be used by putting it back turned up-down at the same side of the disk. If worn knives are used to mow, the cut will be less precise and more power will be used.

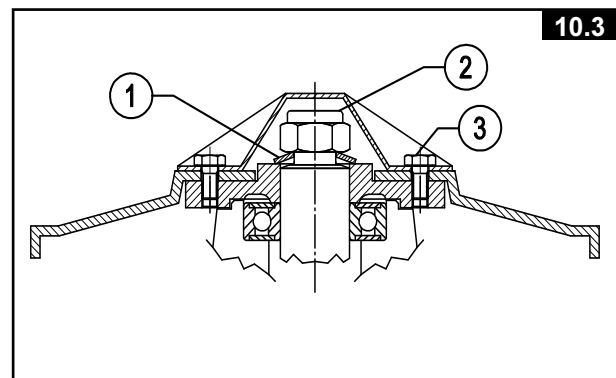
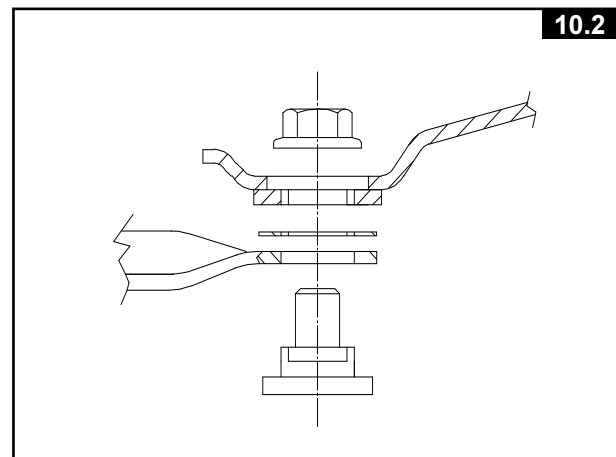
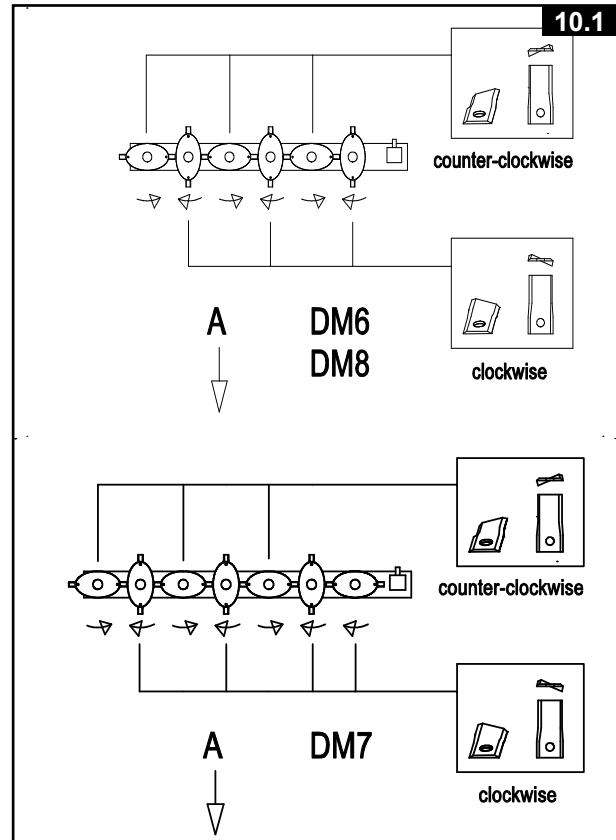

## 10.2 HOW TO CHECK THE MOWING DEVICES

The knives should be replaced when:

- ⇒ the width of the knife at point B=1 cm (0.4 inches) from the edge of the disk is  $\frac{3}{4}$  of the original width A (fig. 10.4).
- ⇒ the oval shape of the hole is more than a distance of C=2 mm (0.08 inches) of the size of the original hole (fig. 10.5).

The clamp parts should be replaced when:

- ⇒ the screw to fasten the knives is bent or too worn out below the head (fig. 10.6).
- ⇒ the self-tapping layer 1 of the screw to fasten the knives is missing or too worn out; we advise changing the screw after it has been tightened 5 times (fig. 10.7).
- ⇒ the clamp screw is worn down where it holds the knife to a distance of E higher than or equal to 3 mm (0.12 inches) (fig.10.8).
- ⇒ the height of the lock nut at any point whatsoever is less than or equal to  $\frac{1}{2}$  of the total nut height (fig. 10.9).

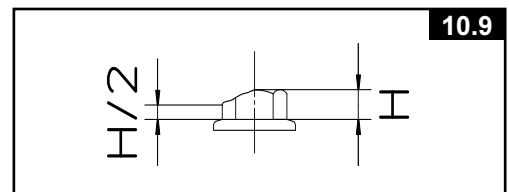
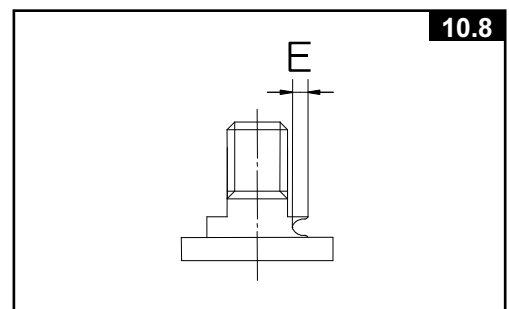
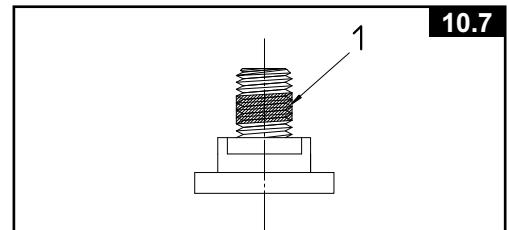
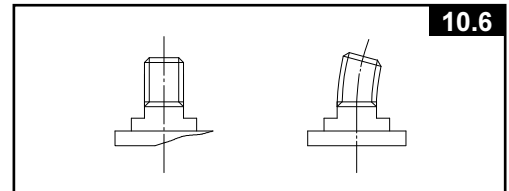
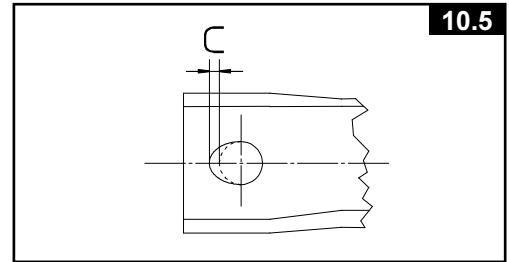
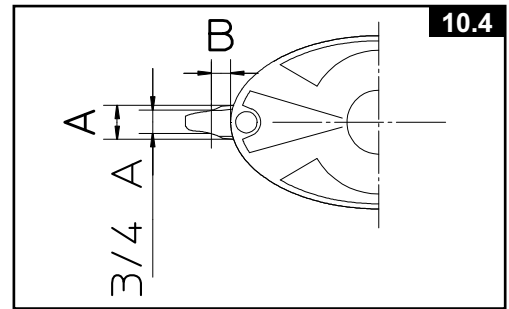

**DANGER !!!**



**Worn out or damaged pieces must be replaced with original spare parts.**

## 10.3 GENERAL MAINTENANCE

Before carrying out any cleaning or maintenance operation etc. comply with all the safety warnings given in this use and maintenance handbook. Before carrying out any operation directly, first:

- switch off the engine;
  - remove the key from the dashboard and put the brake on the tractor;
  - release circuit pressure;
- check that the mower is stable.

The following points should be checked on each new machine 8 working hours:

- the screws are correctly tightened;
- the tension of all the belts;
- that no parts of the hydraulic system are leaking;
- that the driving gear parts are correctly lubricated.

Carry out the following checks regularly particularly at the beginning of each season:

- check/replace the oil, lubricate/grease each point necessary, according to the instructions;
  - check wear and tear of the knives and respective clamp parts;
  - check wear and tear of protection parts;
  - reset correct belt tension;
- check that all the screws are tightened correctly.

Before beginning to mow, make sure that the machine is working correctly and there are no vibrations.

**10.4 LUBRICATION**

Change the oil in the disk carrier bar and the over-gear box after the first 50 hours use. After this first change, we advise changing the oil every 100 working hours or at least once a year.

- The cardan shaft should be greased regularly as shown in fig.10.10.
- The joints, supports, hinges, and points equipped with lubricator as shown in figs. 10.14 should be lubricated or greased frequently, at least every 20 working hours.



**When in use, check the oil levels every day and top up if necessary.**

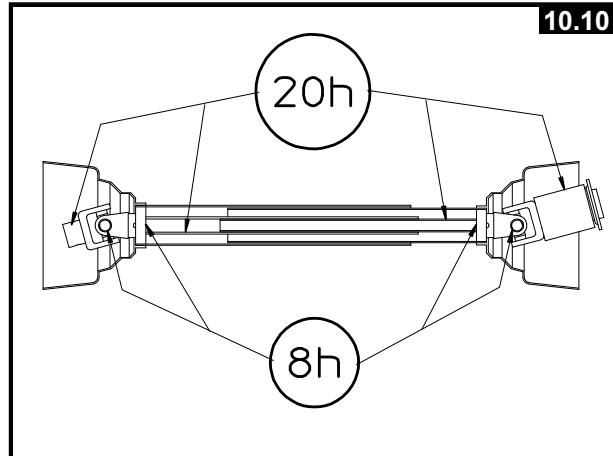

**10.4.1 OVER-GEAR BOX (fig.10.11)**

- 1= drain/loading cap with level rod
- 2= breather cap on disk carrier bar.

Use SAE EP 80 W 90 oil in the quantities shown in the table. Check the level with the special rod on the drain/loading cap when the bar is lying horizontally. Oil can be drained through the hole in cap 1 when the bar is vertical.

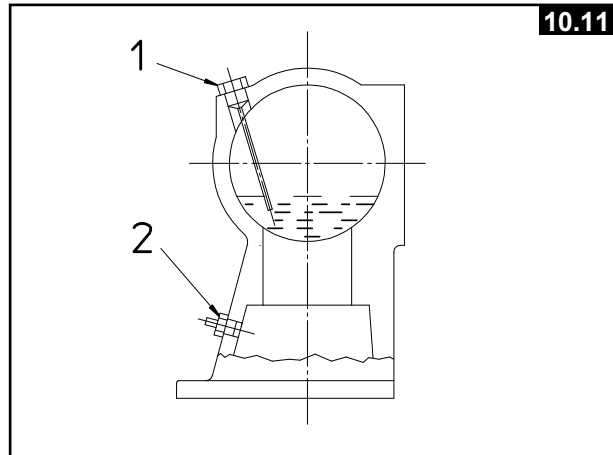

**10.4.2 DISK CARRIER BAR (fig. 10.12)**

- 1= loading cap - level cap
- 2= drain cap

Use SAE EP 80 W 90 oil in the quantities shown in the table.

Oil is loaded and the oil level is checked when the disk carrier bar is vertical (it must have been in the vertical position for at least 5 minutes).

In order to fill up the oil unscrew both caps 1 (filling and level) and pour in the amount shown or the amount needed to top up the level through the hole in cap 1 (tilt the bar slightly if necessary so it is easier to pour in the oil) until the level of cap 1 is reached.

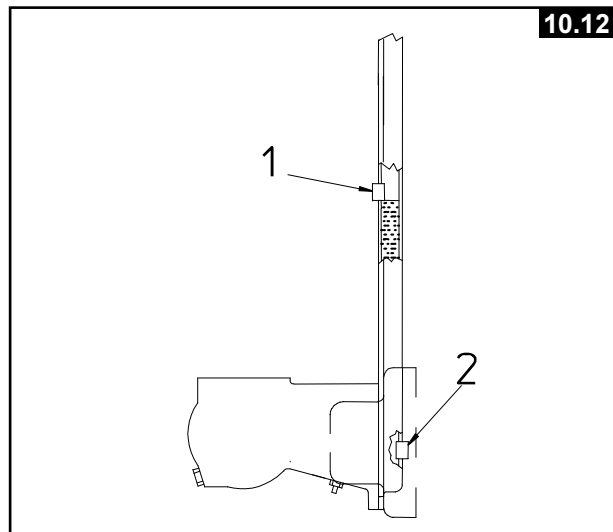

	litres	Gall. UK	Gall. USA
Over-gear box	0,7	0.16	0.19
6 disk bar	2,9	0.64	0.77
7 disk bar	3,6	0.80	0.95
8 disk bar	3,8	0.85	1

**IMPORTANT**

Keep clean this area every 8 working hours from dust or earth accumulated between lever A and frame. Check lever A do not stay up all the time.

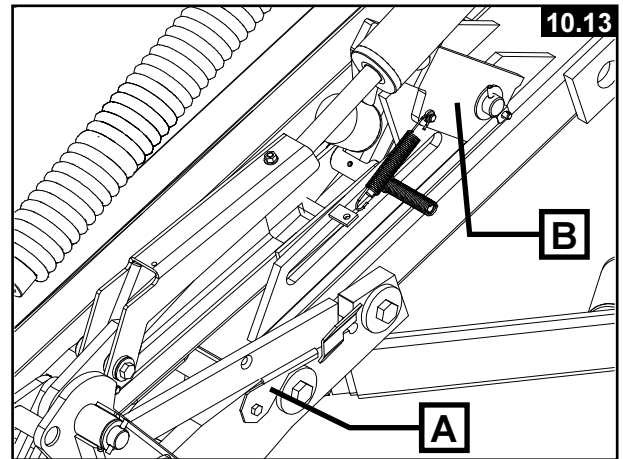

**10.5 END OF SEASON STORAGE**

At the end of the season we recommend storing the machine with the bar lying horizontally after having cleaned it carefully. You should also:

- lubricate and grease each point shown in this use and maintenance handbook;
- protect the areas subject to rubbing with a layer of anti-rust paint;
- loosen the trapezoidal belts and check that the protection plate is lying flat.

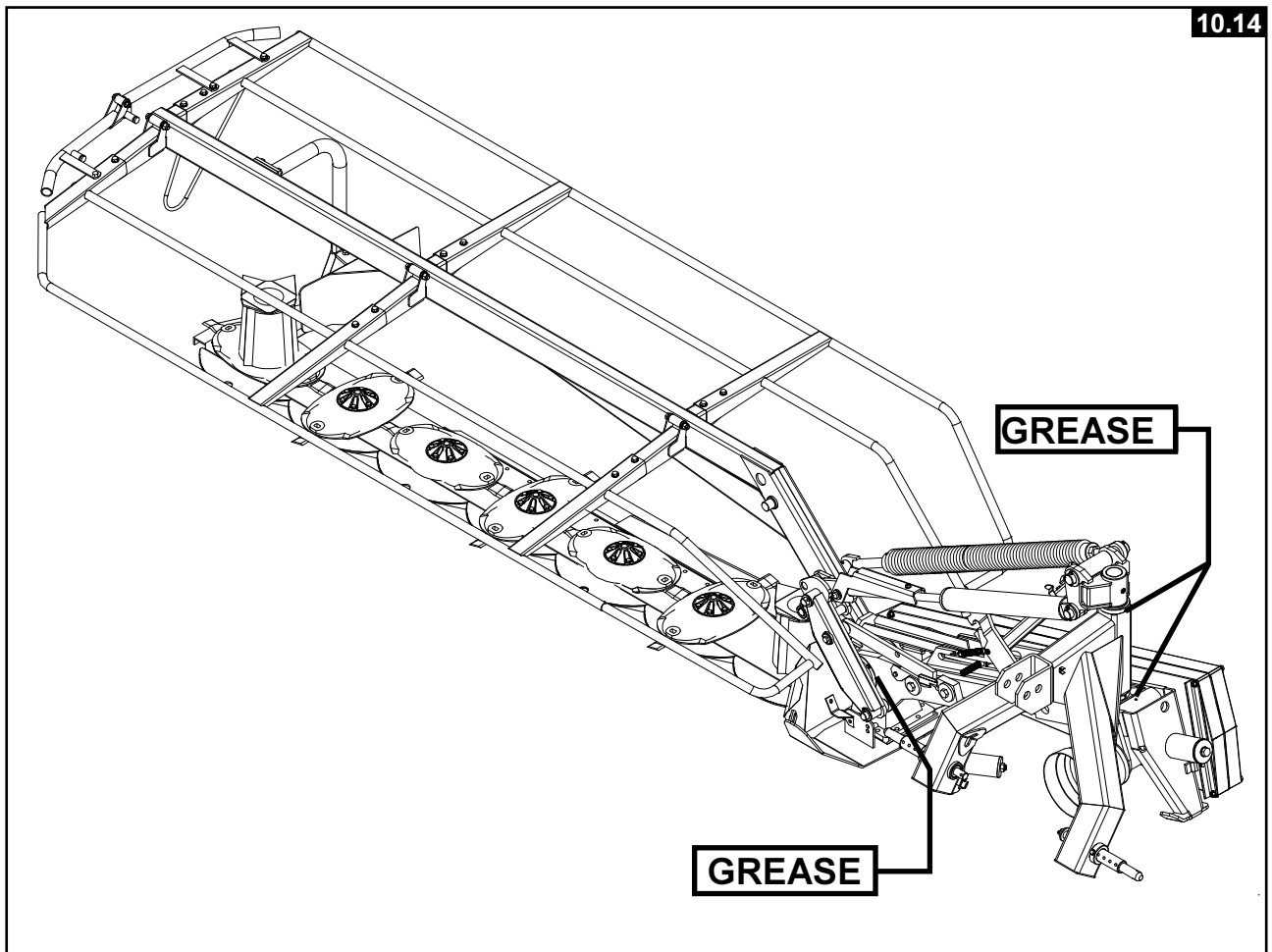





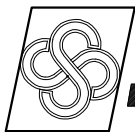

AGRICULTURAL MACHINERY  
**sitrex**® Spq .

Zona Industriale-Viale Grecia, 8  
06018 TRESTINA-(Perugia)-ITALY  
Tel. +39.075.8540021-Telefax +39.075.8540523  
e-mail: sitrex@sitrex.it www.sitrex.com

